

Adjunct valents, cumulative scopings and impossible descriptions

ROBERT D. LEVINE

My focus in this talk is on the consequences of different approaches to extraction phenomena for hypotheses about the syntactic status of adjuncts. So we need to start by looking at the two leading approaches to extraction currently on offer in the HPSG theoretical marketplace.

11.1 Two stories about extraction

11.1.1 Pollard & Sag 1994 (Ch.4)

In constraint-based theories, extraction phenomena have standardly been treated as comprising three components: linking the filler to a SLASH feature which carries the relevant information; propagating that information over arbitrary syntactic distances; and terminating the propagation at possible gap sites. In the Pollard-Sag extraction proposal, SLASH is matched to the filler's LOC properties via the Head-Filler schema given in (1):

- (1) Launching SLASH: the Head-Filler Schema

$$\text{head-filler-phrase} \supset \left[\begin{array}{l} \text{SYNSEM} \left[\begin{array}{l} \text{HEAD } \textit{verb} \\ \text{SUBJ } \langle \rangle \\ \text{COMPS } \langle \rangle \end{array} \right] \\ \text{DTRS} \left[\begin{array}{l} \text{HEAD-DTR|SS|NONLOC} \left[\begin{array}{l} \text{INHERITED|SLASH } \{ \square \} \\ \text{TO-BIND|SLASH } \{ \square \} \end{array} \right] \\ \text{FILLER-DTR|SS|LOC } \square \end{array} \right] \end{array} \right]$$

The Proceedings of the 9th International Conference on HPSG.
 Jong-Bok Kim and Stephen Wechsler.
 Copyright © 2003, Stanford University.

From the point of its introduction to the point its path terminates, SLASH must be shared between mother categories and at least one daughter as per the NFP quoted in (2).

(2) Propagating SLASH: the Nonlocal Feature Principle

In a headed phrase, for each nonlocal feature $F = \text{SLASH, QUE, or REL}$, the value of $\text{SYNSEM|NONLOCAL|INHERITED|F}$ is the set difference of the union of the values on all the daughters and the value of $\text{SYNSEM|NONLOCAL|TO-BIND|F}$ on the HEAD-DTR.

If some daughter category happens to have LOC properties identical to those of a SLASH specification that it shares with its mother category under the NFP, then it will appear as an phonologically empty category under the constraint stated in the lexicon that is conventionally referred to as ‘trace’:

(3) Terminating SLASH: the lexical entry for trace

$$\left[\begin{array}{l} \text{PHON } \langle \rangle \\ \text{SYNSEM } \left[\begin{array}{l} \text{SLASH } \{ \square \} \\ \text{LOC } \square \end{array} \right] \end{array} \right]$$

The three components interact as illustrated in (4) to yield a typical extraction dependency:

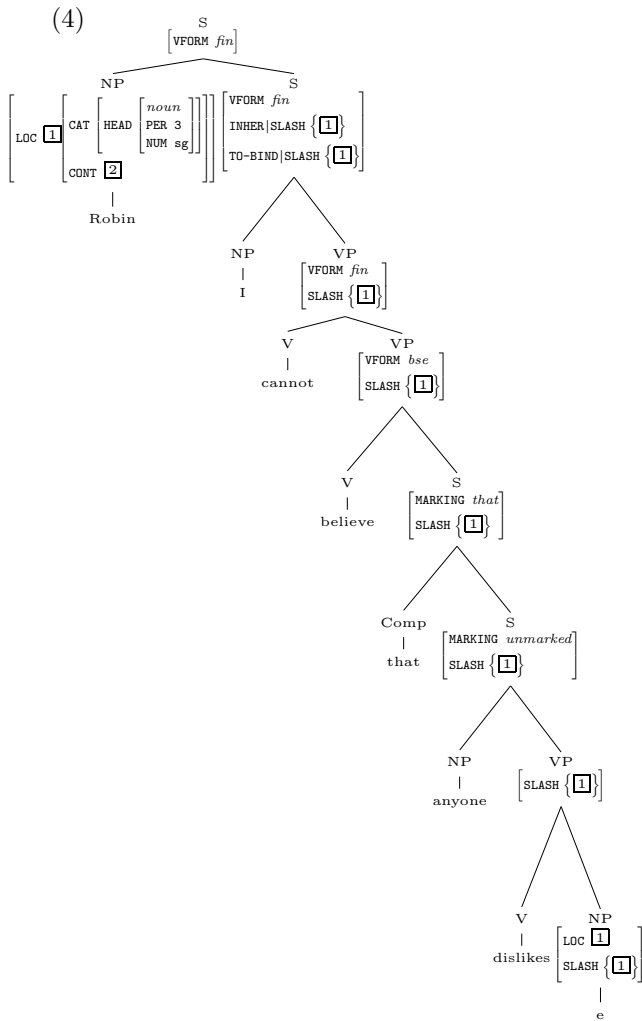

11.1.2 Bouma et al. 2001

In the Bouma et al. (2001) hypothesis, the first component is essentially the same as in Pollard and Sag (1994), with a *hd-filler* phrasal type at the ‘top’ of the dependency, and needs no further comment. But the remaining two differ significantly. For propagating the distribution of SLASH we have the SIP, given in (5)—in all structures except *hd-filler* phrases, SLASH specifications are shared between mother and head daughter—and the SAP given in (6): any SLASH that shows up on a

lexical head must also appear as part of some *synsem-object* on the head's DEPS list, and vice versa.

- (5) Propagating SLASH: the Slash Inheritance Principle

$$\begin{array}{c}
 \text{hd-ph} \\
 \swarrow \quad \searrow \\
 \text{hd-val-ph} \quad \text{hd-fill-ph} \\
 \text{c. } \text{hd-val-ph} \supset \left[\begin{array}{l} \text{SLASH } \boxed{1} \\ \text{HD-DTR} | \text{SLASH } \boxed{1} \end{array} \right]
 \end{array}$$

- (6) Propagating SLASH: SLASH Amalgamation

$$\text{word} \supset \left[\begin{array}{l} \text{LOC} | \text{CAT} \left[\begin{array}{l} \text{DEPS } \langle \boxed{1}, \dots, \boxed{n} \rangle \\ \text{BIND } \boxed{0} \end{array} \right] \\ \text{SLASH } \bigcup_{j=1}^n \boxed{j} - \boxed{0} \end{array} \right]$$

SIP and SAP jointly enforce a lexical threading of SLASH propagation through syntactic structures to the point where SLASH cashes out as a gap, an outcome effected by a combination of SAP, the identification of a DEPS list element with structure-shared LOC and SLASH set membership as a *gap-ss* object via the *gap-ss* constraint, and the Argument Realization Principle, both exhibited in (7):

- (7) Terminating SLASH: SLASH Amalgamation + Argument Realization + the *gap-ss* type definition

The *gap-ss* constraint:

$$\text{gap-ss} \equiv \left[\begin{array}{l} \text{LOC } \boxed{1} \\ \text{SLASH } \{ \boxed{1} \} \end{array} \right]$$

Argument Realization Principle (ARP):

$$\text{word} \supset \left[\begin{array}{l} \text{SUBJ } \boxed{1} \\ \text{COMPS } \boxed{2} \ominus \text{list}(\text{gap-ss}) \\ \text{DEPS } \boxed{1} \oplus \boxed{2} \end{array} \right]$$

SLASH threads lexically as already sketched out to a point in the structure where a lexical head shares that SLASH specification with a DEPS list element satisfying the the *gap-ss* definition in (7), which therefore fails to appear on the head's COMPS list as per the ARP. (8) illustrates the licensing in more detail.

(8)

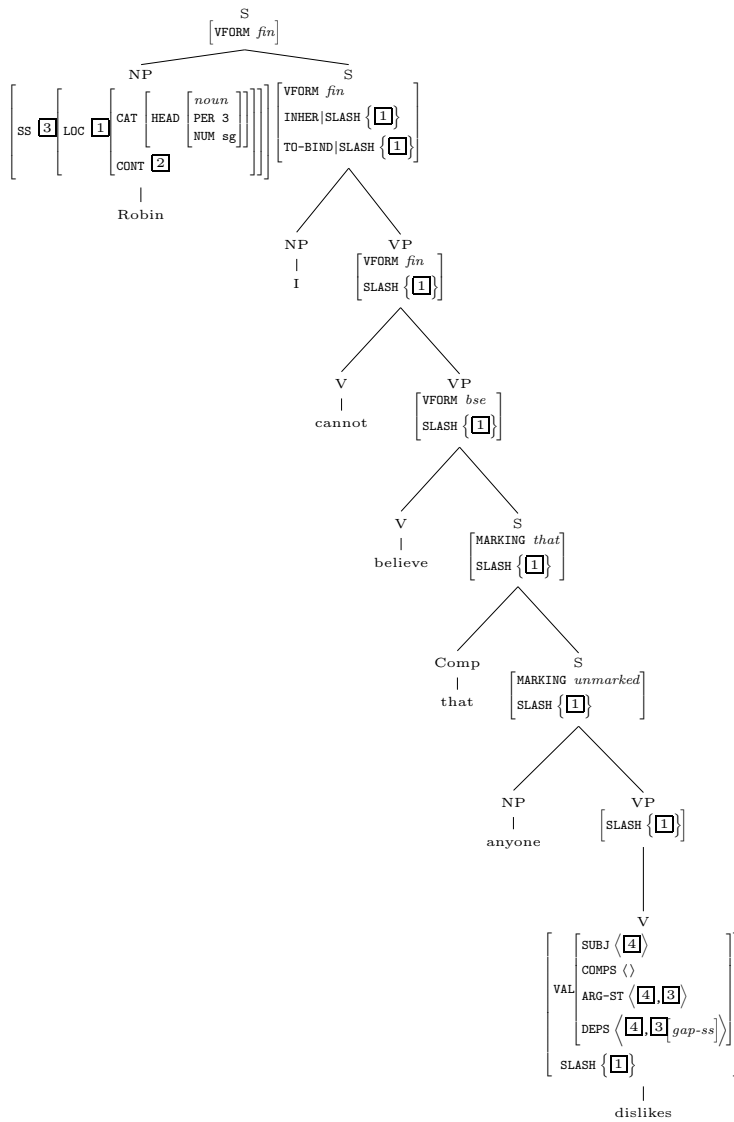

11.2 Adjunct extraction in the BMS framework

How does the extraction of adjuncts fit into these respective pictures? On the Pollard and Sag (1994) treatment of adjuncts as actually adjoined, along the lines of (9), there is little to say. Adverbs, for example, take VP sisters, whose denotations they scope over, and appear in

structures such as (9) under Pollard and Sag's Head-Adjunct Schema:

(9)

a. Robin plays the piano well.

b.

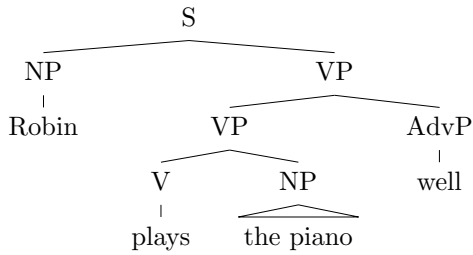

Given this structure, a SLASH matching an adverbial filler in the usual way can propagate to the point where it comes to rest on the AdvP in (9) and, if the same matching holds there, can terminate as a trace just as the complement does in example (4). But how can an adjunct be extracted in the BMS proposal, given that SLASH termination requires a dependent of a verb, a status limited in the ARP to subjects and complements, to have the crucial *gap-ss* type that allows it to then fail to appear (via one of two rather distinct mechanisms). The straightforward solution of course is that BMS reanalyze *extractable* adjuncts as modifier complements, a solution first formally implemented as far as I am aware in van Noord and Bouma (1994). BMS effect this result in rather different fashion, however, employing the relational constraint given in (10) rather than a lexical rule as in previous instantiations of this idea.

(10) Argument Structure Extension

$$verb \supset \left[\begin{array}{l} \left[\begin{array}{l} \left[\begin{array}{l} \text{HEAD } \boxed{3} \\ \text{ARG-ST } \boxed{1} \\ \text{DEPS } \boxed{1} \oplus \text{list} \left(\left[\begin{array}{l} \text{MOD } \boxed{4} \\ \left[\begin{array}{l} \text{HEAD } \boxed{3} \\ \text{KEY } \boxed{2} \end{array} \right] \end{array} \right] \right) \end{array} \right] \end{array} \right] \end{array} \right] \end{array} \right]$$

With this apparatus in place, adjunct extraction works along the following lines. An adverbial sign such as *well* will include the properties displayed in (11):

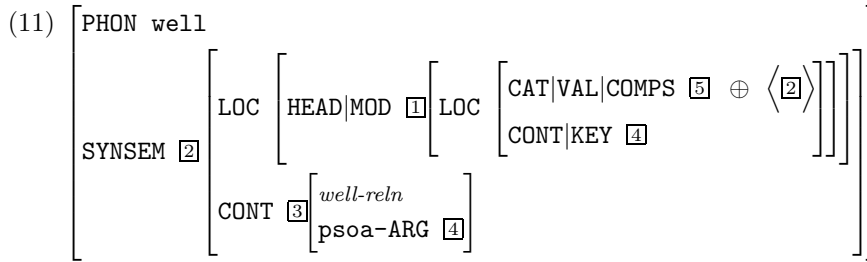

Note that Argument Structure Extension will impose the relevant identifications involving the selecting head on the one hand and the MOD value of the selected adverb on the other. *Robin plays the piano well* will now be licensed along the lines of (12):

(12) a. Robin plays the piano well.

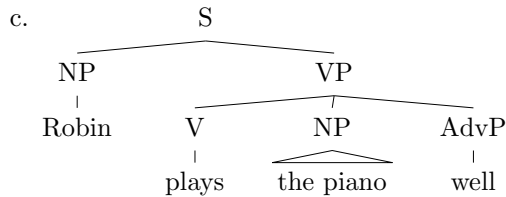
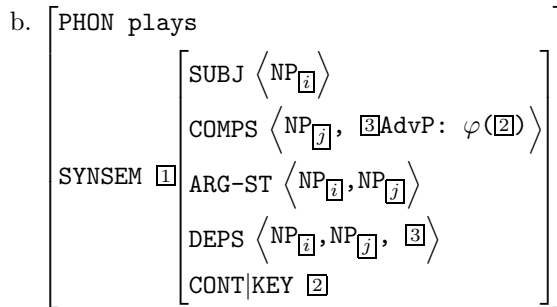

Adjunct extraction now is no different from complement extraction, given that extractable adjuncts aren't adjuncts but rather complements, and is licensed by the interaction of SIP, SAP and ARP in the same way as extraction of nonmodifier complements. There is, however, a crucial aspect of modifier complement extraction which differs fundamentally from 'normal' complement extraction. (13), schematically exhibiting properties which characterize *any* verb from which a modifying adverbial complement has been extracted, makes this difference explicit.

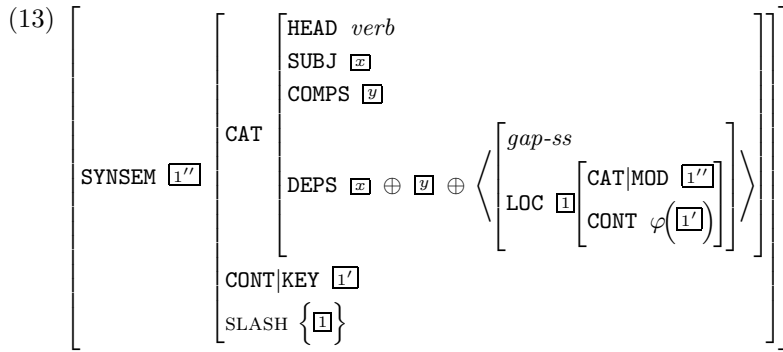

There will, of course, be no *synsem-object* corresponding to the extracted complement modifier; but because the MOD and CONT|KEY specifications of the *gap-ss* object on the head's DEPS list are mandated by Argument Extension to be token-identical to specific properties of the selecting head, it follows that an extracted modifier complement filler, unlike an extracted nonmodifier, is constrained to be consistent with the description of a single selecting head. This is a fact which will come back to haunt us.

A concrete example of adverb extraction is given in (14), where φ_w denotes the interrogative operator that *how well* denotes. SLASH is linked to the filler by the usual *head-filler-phrase* constraints and lexical threading requirements, and, though BMS never spell this out, we can assume that the compositional inheritance of all RELS as in MRS will yield the root clausal properties in (14) making the KEY of *Robin plays the piano* (or the associated event variable, possibly) the argument of φ_w :

(14) a. I wonder how well Robin plays the piano.

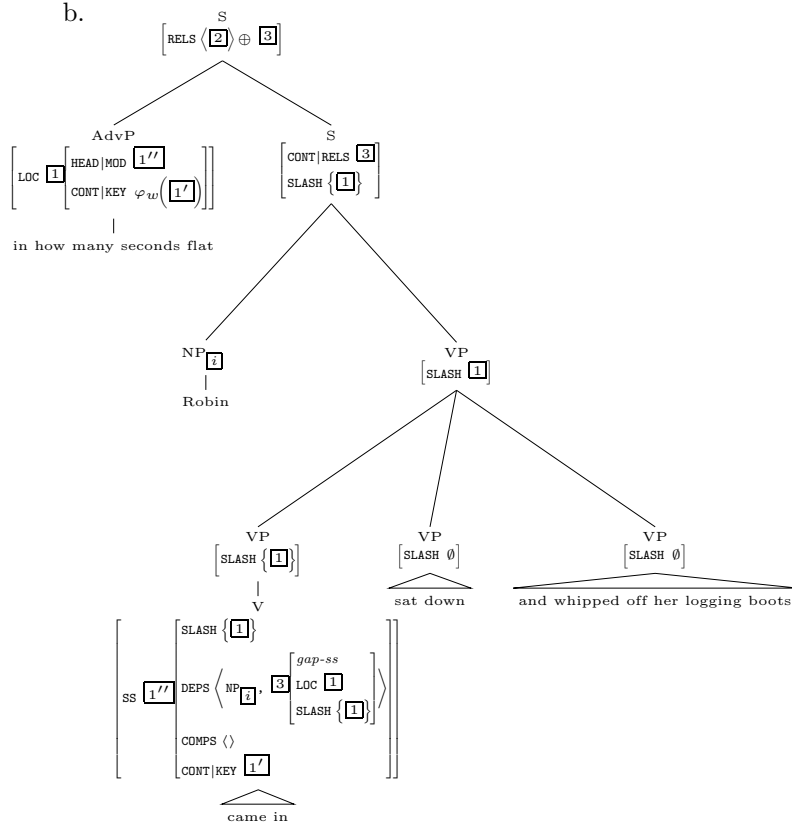

11.3 Cumulative scoping adverbials

With this much in hand, let's now consider what we have to do to account for the examples in (15), particularly (15)b, under the BMS proposal, where (15)c gives what is the overwhelming and for most speakers I believe exclusive reading of this example under the following prosody [pronounce].

- (15) a. Robin came in, found a chair, sat down, and whipped off her logging boots in fifteen seconds flat.
- b. In how many seconds flat did Robin find a chair, sit down and whip off her logging boots?
- c. 'The total time occupied by the serial occurrence $\widehat{e_1 e_2 e_3}$ of the events e_1, e_2, e_3 such that e_1 is the event in which Robin

found a chair, e_2 the event in which Robin sat down, and e_3 the event in which Robin whipped off her logging boots, was fifteen seconds, and this time interval is markedly small relative to the amount of activity represented by $\widehat{e_1 e_2 e_3}$.’

The construction involves a coordination, a nonheaded structure, and so strictly speaking the SIP doesn’t apply to it. What we have to decide then is the question in (16):

(16) What regulates SLASH propagation into coordinate structures?

Possibility 1: Nothing (coordinate structures are not headed).

Possibility 2: The NFP/SIP *anyway*.

Possibility 3: Something stronger than the NFP/SIP.

Suppose we assume Possibility 1. Then (17) is allowed as a possibility, clearly an unacceptable consequence. So even with a coordination, there has to be some kind of gap within it if there’s a filler outside it.

(17) Re Possibility 1:

*Which books did Leslie read a newspaper and Terry try to get certain magazines banned from the library?

What about the second possibility?

(18) Re Possibility 2:

- a. *Which books did Leslie read a newspaper and Terry try to get banned __from the library?
- b. It’s the kind of book which you wind up walking around aimlessly and thinking about __all the time you’re reading it.

So the facts could go either way here. Assume that nothing stronger than the NFP/SIP is involved. What would that lead us to posit as the structure of sentences like (15)b? The answer is that for (19)a, we get (19)b, which directly translates into the interpretation (19)c:

(19) Re Possibility 2:

- a. I wonder in how many seconds flat Robin came in, sat down and whipped off her logging boots.

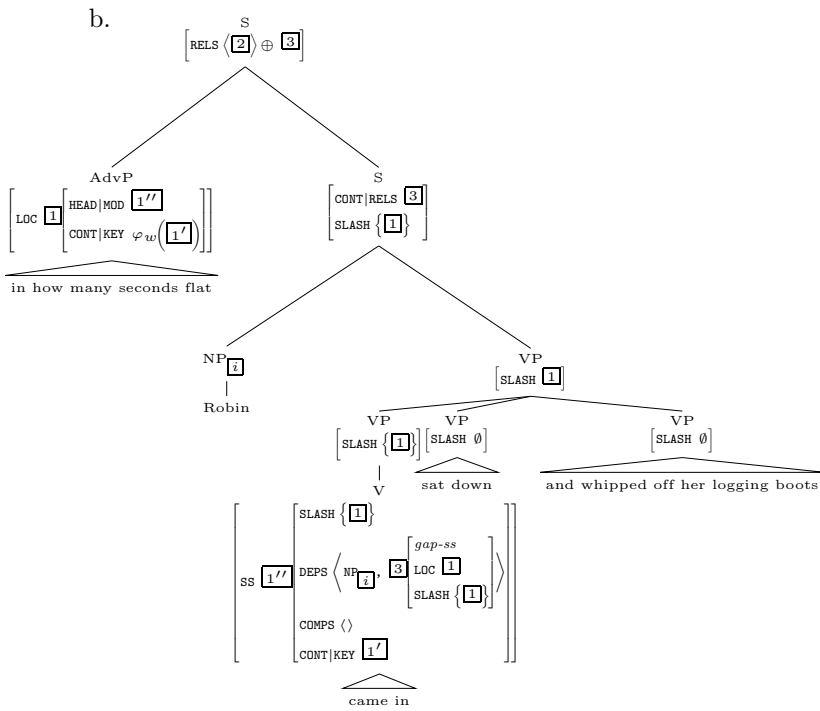

- c. ‘There was a serial occurrence $e_1e_2e_3$ of the events e_1, e_2, e_3 such that e_1 is the event in which Robin found a chair, e_2 the event in which Robin sat down, and e_3 the event in which Robin whipped off her logging boots, and I wonder what time interval was occupied by e_1 .’

Clearly, this too is an undesired outcome.

We still have possibility 3 to consider. Suppose we adopt something like the ‘Weak Coordination Principle’ briefly considered in Pollard and Sag (1994), given in (20)—would that give us the result we want?

- (20) The ‘Weak Coordination Principle’ (Pollard and Sag (1994), p.203): in a coordinate structure, the CAT and NONLOC values of each conjunct daughter are subsumed by those of the mother.

What we wind up with is displayed in (21):

(21) Re Possibility 3:

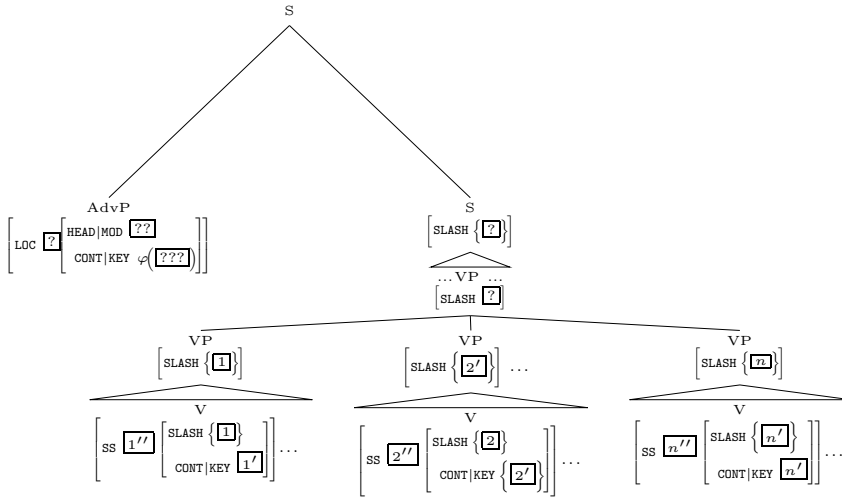

What we have here is a description that would be impossible for any sign to satisfy: a single filler must simultaneously satisfy an arbitrary number of mutually exclusive identities. Careful examination of (13) makes clear that *every single head* in the coordination will require the modifier complement *gap-ss* object on its DEPS list to incorporate the identities specified in (13). But those identities will involve distinct values for MOD and KEY in each conjunct, so that each of the *gap-ss* objects corresponding to the extracted filler will be token-distinct. Yet the *head-filler-phrase* constraints, the SIP and the SAP jointly require the single filler’s LOC value to be simultaneously equal to *n gap-ss* LOC values, none of which are equal to any of the others—an impossible outcome. Or, looking at it from another angle, we have an inevitable breakdown in one of our other necessary assumptions—the Weak Coordination Principle, the SAP or SIP—somewhere along the line. Clearly, some changes are in order.

11.4 Possible responses

11.4.1 Allow selection/scoping mismatches in head/adjunct relations?

The source of the difficulty we have identified with the BMS account of adjunct extraction arises from the confrontation between the filler’s specifications on the one hand and the distinct properties of each selecting head on the other. To ameliorate this conflict, we might consider

but what we *can* modifying the BMS formulation of Argument Structure Extension, itself a leftover from the Pollard/Sag MOD principle. The two technologies apparently turn out to fit together poorly; to do BMS-style adjunct syntax, it might appear, we need instead the version in (22):

(22) Revised Argument Structure Extension:

$$verb \Rightarrow \left[\begin{array}{l} \text{HEAD } \boxed{3} \\ \text{DEPS } \boxed{1} \oplus \text{list} \left(\left[\text{MOD } \left[\begin{array}{l} \text{HEAD } \boxed{4} \\ \text{CONT|KEY } \boxed{5} \end{array} \right] \right] \right) \\ \text{ARG-ST } \boxed{1} \\ \text{CONT|KEY } \boxed{2} \end{array} \right]$$

Compare (21) with (23) to see what this change in the ASE lets you do:

(23)

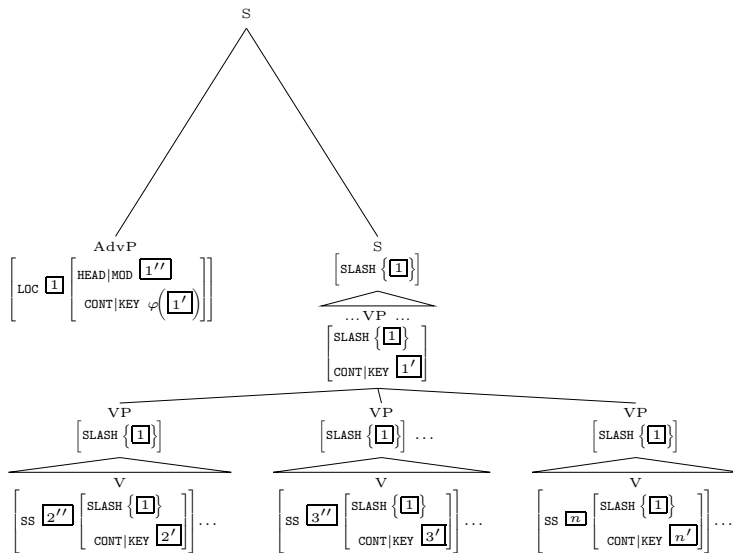

This structure seems to get the story right: there is a selected adjunct in each conjunct which is extracted, but the adjunct in each conjunct has the same LOC value as the other adjuncts, and the CONT value of that LOC specification is identical to the CONT of the entire coordinate VP.

But matters are more complicated than this. What constrains the relationship between the argument of the adjunct functor on the one hand and the semantics of the selecting verb on the other? Without some explicit restrictions, we admit possible objects like the one in (24), corresponding to outlandish interpretations that *no one* gets. Unless we can force the right identifications so as to have adjuncts in situ scope over the VPs they actually combine with, for example, nothing will block the identities in (24)b, giving rise to the interpretation (24)c for (24)a. This is clearly an outcome we don't want. And the possibilities for coordinate constructions with adjuncts in the different conjuncts allow this kind of misinterpretation to run rampant. The description in (25), for example, leads in the absence of further restrictions to the interpretation in (26).

(24) a. That Robin plays the piano often, I believe that Leslie has noted.

b. *often*:

$$\begin{bmatrix} \text{MOD } \boxed{1} \text{ IND } e_\omega \\ \text{KEY } \varphi(e_\omega) \end{bmatrix}$$

noted:

$$\begin{bmatrix} \boxed{1} \text{ CONT} \begin{bmatrix} \text{IND } e_\omega \\ \text{RELS } \left\langle \begin{bmatrix} \text{note} \\ \text{EVENT } e_\omega \\ \text{ARG1 } \boxed{3} \\ \text{ARG2 } \boxed{4} \end{bmatrix} \right\rangle \\ \text{KEY } \boxed{2} \end{bmatrix} \end{bmatrix}$$

c. 'I believe that there have been a large number of events in which Leslie has noted that Robin plays the piano.'

$$(25) \quad \text{verb} \Rightarrow \begin{bmatrix} \text{HEAD } \boxed{3} \\ \text{DEPS } \boxed{1} \oplus \text{list} \left(\begin{bmatrix} \text{MOD} \begin{bmatrix} \text{HEAD } \boxed{4} \\ \text{CONT|KEY } \boxed{5} \text{ [EVENT } e_\omega \text{]} \end{bmatrix} \\ \text{CONT|KEY } \boxed{2} \text{ } [\varphi(e_\Omega)] \end{bmatrix} \right) \end{bmatrix}$$

where $e_\Omega = \widehat{\dots e_\omega \dots}$

- (26) a. Robin came in, found a chair, sat down, changed seats four times and whipped off her logging boots in fifteen seconds flat.
 b. ‘There were four separate events each of which comprised Robin coming in, finding a chair, sitting down, changing seats and whipping off her logging boots, and the duration of these separate events was fifteen seconds, etc.’

What kind of restriction should we impose to avoid such difficulties? One plausible candidate would be to restrict the possible modification target of a selected adverbial to a (possibly) complex event of which the event corresponding to the selecting head is a part. This is, after all, the kind of interpretation that we wish to derive in (24) (23), and it would be reasonable to hope that such a restriction, embodied for example in some further revision of BMS’s Argument Structure Extension constraint, would do the trick. But this specific restriction *doesn’t*. So consider (26)a. The adverbial phrase *in fifteen seconds flat* strongly encourages interpretation of the conjunction as a complex event, one of whose subevents is a seat-changing event. Therefore, the adverbial modifier of *change* in this VP conjunction could, under the restriction I’ve just sketched, identify its MOD value with that of the complex event corresponding to the entire coordinate VP, yielding the interpretation in (25)b—again, not an inference sanctioned by the grammar of English with respect to (25)a.

- (27) a. Robin came in, found a chair, sat down, changed seats four times and whipped off her logging boots in fifteen seconds flat.
 b. ‘There were four separate events each of which comprised Robin coming in, finding a chair, sitting down, changing seats and whipping off her logging boots, and the duration of these separate events was fifteen seconds, etc.’

11.4.2 A special construction type?

An alternative possibility is that to get the right outcome, it is going to be necessary to posit a special construction type. You can do it explicitly in the syntax, or you can in effect build it into the syntax/semantics interpretation principles along the lines of constructionally imposed handle equations in MRS, except that I suspect you will find the conditions on quantifier scoping far easier to get exactly right than modifier scoping. For example, to get the revised version of Argument Structure Extension to work, you need to state something that looks like (28):

$$(28) \left[\begin{array}{l} \text{cumulative-adverbial-scope-coord-struct} \\ \text{SYNSEM } \boxed{1} | \text{KEY} | \text{EVENT } e_\Omega \\ \text{COORD-DTRS } \bigoplus_{j=1}^n \left\langle \boxed{j} \left[\begin{array}{l} \text{phrase} \\ \text{HEAD } \boxed{j'} \text{verb} \\ \text{SLASH } \boxed{2} \end{array} \right] \right\rangle \end{array} \right] \\ \wedge \forall j' \left[\begin{array}{l} \text{word} \\ \text{HEAD } j' \\ \text{COMPS } \boxed{3} \oplus \left\langle \boxed{4} | \text{LOC } \boxed{2} \left[\begin{array}{l} \text{MOD } \boxed{1} \\ \text{KEY } \varphi(e_\Omega) \end{array} \right] \right\rangle \end{array} \right]$$

Informally, this constraint on a coordinate structure of type *cumulative-adverbial-scope-extraction-coord-struct* allows such a structure to be linked to a filler whose interpretation follows from application of a functor reflecting the denotation of the filler to an argument denoted by the coordinate VP, or perhaps more correctly, to the conjunction of event variables bound respectively to each of the VP conjuncts.

This account is, however, still not sufficient; it is still necessary to provide for multiple scoping possibilities between selected modifiers on the right, sisters of the selecting head, and true adjuncts, combining with whole VPs. The BMS system seems to suggest that the latter will always outscope the former, and BMS in a footnote seem to claim this explicitly. Given a simple approach to the syntax/semantics interface, that is, we can expect the situation in (29), where the assumption seems to be that the selected modifier will scope only over its context of appearance.

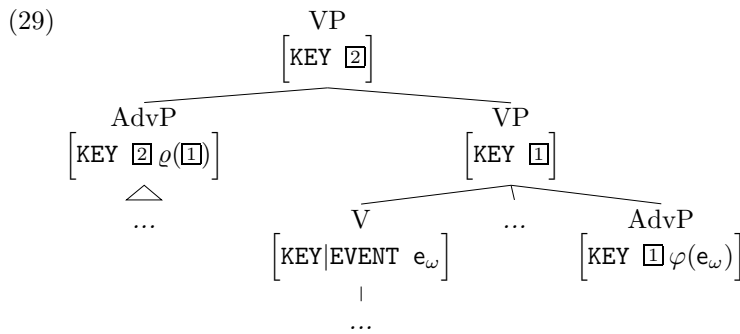

But the facts do not support this claim. It is not at all difficult to construct cases which can go both ways, e.g.:

- (30) a. How many times did Robin fall asleep?
 b. Robin almost fell asleep a record-breaking number of times.

There are two readings here: Robin came close to breaking a record for falling asleep, or Robin actually broke a record for almost falling asleep.

11.5 Pollard & Sag 1994 revisited

It is worth stressing at this point that all of the facts discussed so far—the possibility and correct interpretation of adjunct extractions involving cumulative scoping, the correct interaction between adjunct scoping in various parts of complex structures, the scoping ambiguities that hold between right-adjoined unextractable modifiers and extractable modifiers on the left—fall out unremarkably from the Pollard and Sag (1994) treatment of adjuncts that I started this talk by sketching, along with the assumption that adjuncts in adjoined positions can extract. Since, on my analysis, real adjuncts occur on the right as well as the left, SLASH termination cannot involve a DEPS list element (or an ARG-ST list element, in the case of a BMS-style of analysis which dispenses with DEPS entirely). Powerful locality considerations mandate that such properties be confined to lexical heads. And that means that SLASH paths be terminated by traces. To see how this works just with the cumulative scoping extraction phenomena, compare (21), or (23) plus (28) plus whatever, with (31):

(31)

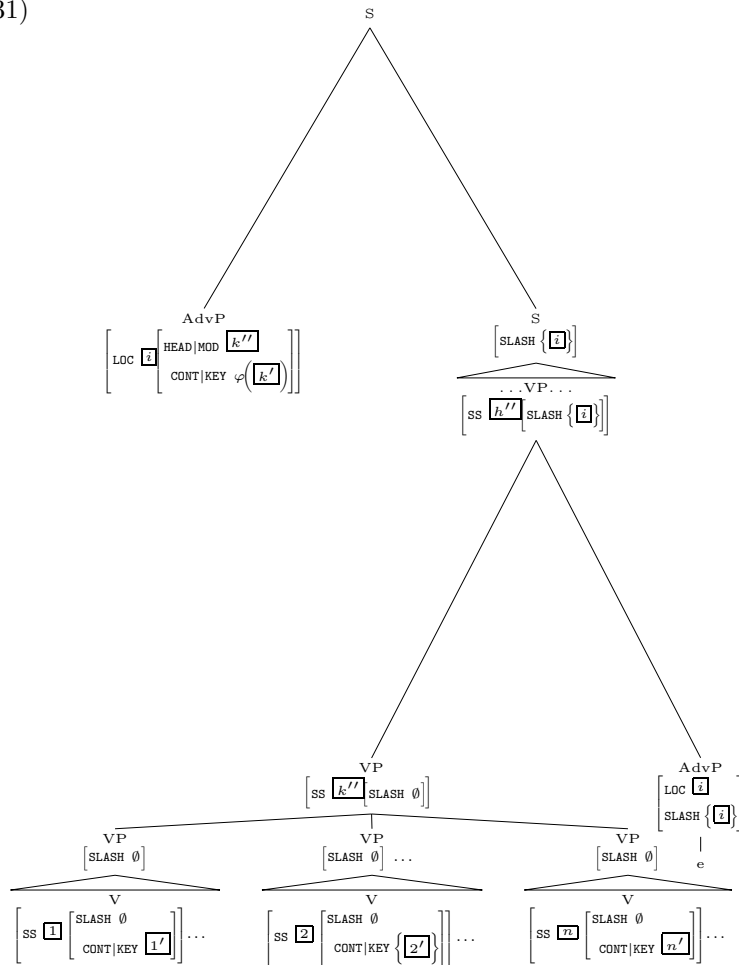

There's virtually nothing to say beyond this structure, which has the adjunct functor taking exactly the data structure it needs to—the complex event description corresponding to the trace's VP sister—to yield exactly the right result. And the other phenomena I've referred to fall out equally directly on the traceful analysis.

At this point, it would be reasonable to suggest that I'm not really off the hook, that extractability isn't the only reason for making modifiers complements. The range of other phenomena taken to constitute particularly strong support of such a move is conveniently summarized in BMS as follows:

we find in many languages types of adverbials that defy any simple analysis in terms of the syntactic combination of modifiers and head. In particular, it has been argued that cliticization (Miller 1992), word order (van Noord and Bouma 1994; Abeillé and Godard 1997), scope (Manning et al. 1999; van Noord and Bouma 1994; Kim and Sag 1995; Przepiórkowski 1999a), and case marking (Przepiórkowski 1999b,c) suggest that certain adverbial phrases must be selected for by the same mechanism which accounts for the selection of complements.

Space considerations preclude a detail treatment of all of these issues. But I think I CAN outline a straightforward treatment of at least one of the phenomena that have been claimed to defy any simple account on Pollard and Sag (1994)'s adjunct syntax, and maybe hint at how the other alleged difficulties for that syntax can be treated.

The original call for the kind of analysis of adjuncts defended in BMS, first proposed in van Noord and Bouma (1994), actually invokes extractability only casually in passing. Much more urgent in demanding a reanalysis of adjuncts as complements are the properties of predicate complexes such as that exhibited in 32:

- (32) dat Arie vandaag Bob wil slaan
 that Arie today Bob want to-hit
 'that Arie wants to hit Bob today'

van Noord and Bouma observe that

[Such examples]are systematically ambiguous between a wide-scope reading (adjunct modifies the event introduced by the auxiliary) or a narrow-scope reading (adjunct modifies the even introduced by the main verb)...The main problem for [the Pollard & Sag] treatment of adjuncts is that it cannot explain the narrow-scope reading... If adjuncts modify the head of the phrase they are part of then we will only obtain the wide-scope readings.

This argument is essentially recapitulated for parallel facts in Japanese in Manning et al. (1999). But does it necessarily hold up? In the following discussion I draw both on independent work by Nick Cipollone presented in Cipollone (2001) and also on my current joint with Nick.

Consider the following two possibilities:

- propositions are not atomic but rather are structured objects, along lines proposed in, e.g., Creswell and von Stechow (1982), Creswell (1985), and much other work since, and explicitly built into current type-logical variants of categorial grammar via the π functions that operate on dot-product expressions in the Lambek calculus;

- semantic representations in HPSG *CONTENT* specifications should incorporate representations expressed in convention lambda calculi, a proposal currently actually realized in much very current work on HPSG semantics.

What I'm proposing here is therefore not particular outré or even novel. Encoding lambda expressions in AVM notation is also quite straightforward. Consider an expression of propositional type in ordinary Montegovian IL, as in (33)a. It can of course be rewritten as (33)b, and which in turn can be notated in AVM format as (33)c:

$$(33) \quad \begin{array}{l} \text{a. } \psi(\varphi(r)) \\ \text{b. } \lambda p[\psi(p)] \lambda q[\varphi(q)] \cdot r \\ \text{c. } \left\langle \left[\begin{array}{l} \text{LAMBDA } p \\ \text{PSOA } \psi(p) \end{array} \right], \left[\begin{array}{l} \text{LAMBDA } q \\ \text{PSOA } \psi(q) \end{array} \right], r \right\rangle \end{array}$$

Taking the structured meaning view of propositions, however, we distinguish the objects in (33)a and b, while still allowing β -reduction to be truth-preserving. Thus in (34), we allow a. and b. to differ as objects even though the former reduces to the latter:

$$(34) \quad \begin{array}{l} \text{a. } \lambda p[\textit{cause}'(x, p)](\textit{run}'(y)) \\ \text{b. } \textit{cause}'(x, \textit{run}'(y)) \end{array}$$

Note that only unreduced λ -expressions of the form in (35) are allowed:

$$(35) \quad \lambda p[\psi(p)](\cdot) \text{ where } p \text{ is a variable over propositions (soas)}$$

The framework I'm assuming here does not provide for arbitrary λ -expressions.

To map ordinary *CONT* specifications the lambda-enriched version I advocate here, simply replace all *content* values of type *psoa* with lists of elements of a new type, *psoa-abstract*, with appropriate features as in (36).

$$(36) \quad \left[\begin{array}{l} \textit{psoa-abstract} \\ \text{LAMBDA} \quad \textit{var}(\textit{psoa}) \vee \textit{none} \\ \text{PSOA} \quad \textit{psoa} \end{array} \right]$$

psoa-abstracts with LAMBDA values of type *psoa* represent λ -abstracts over *psoas*, while those with LAMBDA equal to *none* are the equivalent of simple *psoas*. A list of *psoa-abstracts* is interpreted as a chain of functional application.

This encoding makes embedded *psoa*s accessible to modification by ‘external’ adverbs. A typical modifier in this setup has the form in (37).

$$(37) \left[\begin{array}{l} \text{MOD|CONT } \boxed{1} \oplus \left\langle \left[\begin{array}{l} \text{LAMBDA } \boxed{2} \\ \text{PSOA } \boxed{3} \end{array} \right] \right\rangle \oplus \boxed{4} \\ \text{CONT } \boxed{1} \oplus \left\langle \left[\begin{array}{l} \text{LAMBDA } \boxed{2} \\ \text{PSOA } \varphi(\boxed{3}) \end{array} \right] \right\rangle \oplus \boxed{4} \end{array} \right]$$

Now let’s rejoin van Noord and Bouma’s example, taking *vandaag* to have the partial description in (38):

$$(38) \text{ vandaag: } \left[\begin{array}{l} \text{MOD|CONT } \boxed{1} \oplus \left\langle \left[\begin{array}{l} \text{LAMBDA } \boxed{2} \\ \text{PSOA } \boxed{3} \end{array} \right] \right\rangle \oplus \boxed{4} \\ \text{CONT } \boxed{1} \oplus \left\langle \left[\begin{array}{l} \text{LAMBDA } \boxed{2} \\ \text{PSOA|NUC } \left[\begin{array}{l} \textit{temporal-location} \\ \text{LOCATION } \textit{yesterday} \\ \text{EVENT } \boxed{3} \end{array} \right] \end{array} \right] \right\rangle \oplus \boxed{4} \end{array} \right]$$

In our lambda-enriched CONT specification, the representation of *Arie vandaag Bob wil slaan* in (39)a will be that (39)b:

$$(39) \text{ a. Arie vandaag Bob wil slaan}$$

$$\text{ b. } \left[\begin{array}{l} \text{CONT } \boxed{1} \left\langle \left[\begin{array}{l} \text{LAMBDA } \boxed{3} \\ \text{PSOA|NUC } \left[\begin{array}{l} \textit{want-reln} \\ \text{ARG1 } \boxed{2} \\ \text{ARG2 } \boxed{3} \end{array} \right] \right] \right\rangle, \left[\begin{array}{l} \text{LAMBDA none} \\ \text{PSOA|NUC } \left[\begin{array}{l} \textit{hit-reln} \\ \text{HITTER } \boxed{2} \\ \text{HITTEE } \boxed{4} \end{array} \right] \right] \right\rangle \end{array} \right]$$

Notice how this CONT specification interacts with the specification for *vandaag* in (38). To get wide scope for the main verb *wil*, we nondeterministically allow $\boxed{1}$ in (38) to be (40), and $\boxed{2}$ to be (41).

$$(40) \left[\begin{array}{l} \text{LAMBDA } \boxed{3} \\ \text{PSOA|NUC } \left[\begin{array}{l} \textit{want-reln} \\ \text{ARG1 } \boxed{2} \\ \text{ARG2 } \boxed{3} \end{array} \right] \end{array} \right]$$

$$(41) \left[\begin{array}{l} \text{LAMBDA none} \\ \text{PSOA|NUC} \left[\begin{array}{l} \textit{hit-reln} \\ \text{HITTER } \boxed{77} \\ \text{HITTEE } \boxed{77} \end{array} \right] \end{array} \right]$$

Then the ordinary Pollard/Sag syntax for adjunct will yield the supposedly unavailable wide scope reading for *wil*, as shown in (42)a. Taking $\boxed{1}$ to be the empty list, we get (42)b, yielding wide scope for *vendaag*.

(42) a.

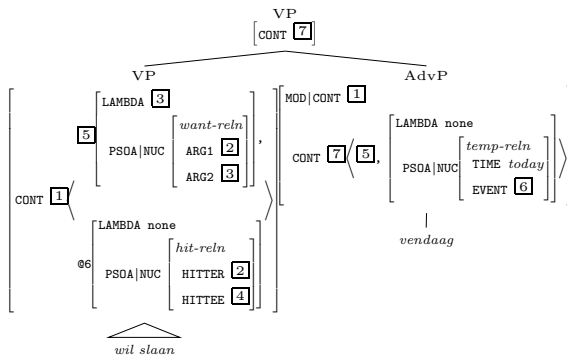

b.

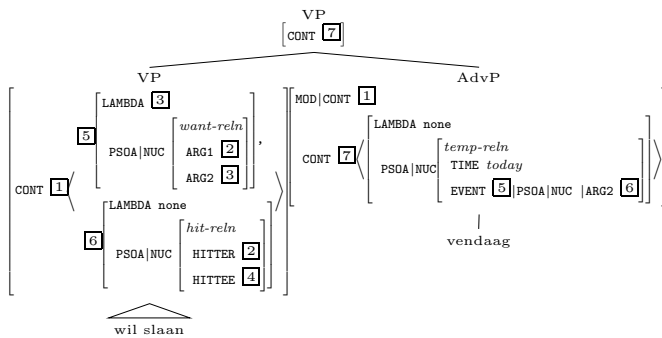

11.6 Conclusion

The preceding sketch of a structured-proposition compositional semantics is not intended to be definitive; and it is entirely possible that some alternative which allows the same range of scoping alternatives exists which is preferable. My point is rather to offer a proof of existence for a view of the syntax/semantics interface which undercuts the crucial assumption in van Noord and Bouma (1994) and Bouma et al. (2001) that adjunct syntax along the lines of Pollard and Sag (1994) is incompatible with the scoping possibilities of adjunct modifiers.

More generally, I hope to have shown that there are significant open questions bearing on the viability of any treatment of extractable adjuncts which assimilates their status to that of full complements—questions which do not arise on the picture of adjunct syntax in Pollard and Sag (1994). Space considerations preclude exploration of further issues that arise in this connection, such as the semantic difficulties which emerge when one attempts to apply BMS' specification of the Argument Structure Extension constraint to instances of iterated modification, as in *Robin played the piano well only once*, or the range of data BMS allude to in which adjuncts appear to undergo case marking and other processes in a manner strictly parallel to complements. These questions deserve—and will, I hope, shortly receive—much fuller discussion. For the moment, the crucial point seems to me to be that there of extractable adjuncts as COMPS list element, and that these consequences need to be faced squarely, and in detail, before such a move can be considered fully secure.

Acknowledgements

I am greatly indebted to a number of individuals and audiences for constructive criticism and encouragement in the work reported in this paper. In particular, I am grateful for the chance to present parts of the material in this paper to audiences at King's College, University of London; the Georg-August Universität, Göttingen; the Universität des Saarlandes; the Eberhart-Karl Universität, Tübingen, as well as my coparticipants in the 2002 HPSG Conference at Kyung Hee University in Seoul Korea, whose organizers treated their guests with a warmth and generosity that none of us will ever forget. I particularly appreciate the feedback I have received from Bob Borsley, Erhard Hinrichs, Gert Webelhuth and especially Ivan Sag. Nothing should be assumed about the opinions of any of these people about anything, and responsibility for all errors is mine.

References

- Bouma, Gosse, Rob Malouf, and Ivan Sag. 2001. Satisfying constraints on extraction and adjunction. *NLLT* 19:1–65.
- Cipollone, Dominic. 2001. Morphologically complex predicates in japanese and what they tell us about grammar architecture. In M. Daniels, D. Dowty, A. Feldman, and V. Metcalf, eds., *Ohio State University Working Papers in Linguistics 56: Varia*. Ohio State University Department of Linguistics.
- Creswell, Max and Arnim von Stechow. 1982. De re belief generalized. *Linguistics and Philosophy* 5:505–535.
- Creswell, M. J. 1985. *Structured Meanings*. Cambridge, Mass: MIT Press.
- Manning, Chris, Ivan Sag, and MKasayo Iida. 1999. The lexical integrity of japanese causatives. In *Studies in Contemporary Phrase Structure Grammar*. Cambridge, U. K.: Cambridge University Press.
- Pollard, Carl J. and Ivan Sag. 1994. *Head-Driven Phrase Structure Grammar*. Chicago: University of Chicago Press.
- van Noord, Gertjan and Gosse Bouma. 1994. Adjuncts and the processing of lexical rules. Proceedings of COLING.