

The Morphology of German Particle Verbs: Solving the Bracketing Paradox

Stefan Müller

DFKI GmbH
Language Technology Lab
Stuhlsatzenhausweg 3
66 123 Saarbruecken, Germany

November 15, 2001

1 Introduction

Inflectional affixes are sensitive to morphological properties of the elements they attach to. Therefore Bierwisch (1987) suggested that the inflectional material is combined with both the verbal stem of simplex verbs and the verbal stem of particle verbs. He argued that this leads to the bracketing paradox in the case of particle verbs since the semantic contribution of the inflectional information scopes over the semantic contribution of the complete particle verb. This paradox will be discussed in section 2.1. In section 2.2, I will discuss nominalizations and adjective derivation, which are also problematic because of various bracketing paradoxes. In section 3 I will suggest a solution to these apparent paradoxes that assumes that inflectional and derivational prefixes and suffixes always attach to a form of a stem that contains the information about a possible particle already, but without containing a phonological realization of the particle. The particle is a dependent of the verb and is combined with its head after inflection and derivation. With such an approach no rebracketing for the analysis of particle verbs mechanisms are necessary.

2 The Phenomena

2.1 Inflection

Both particle and prefix verbs always have the same inflection class as their base verb. This means that the inflectional suffix has to have access to the morphological features of the stem. This is accounted for easily with a structure like the one in figure 1a. Bierwisch (1987, p. 163) argues that the meaning of the verb *aufhören* ('end') is not

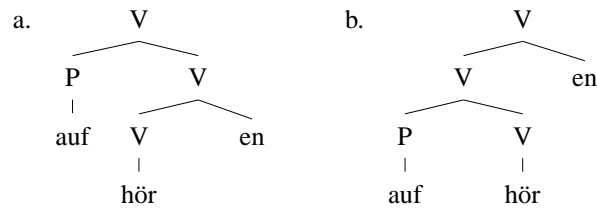

Figure 1: Alternative Structures for *aufhören*

transparent with regard to the combination of *auf* and *hör-*, but combinations of the form *auf-hör-t-est* and *auf-ge-hör-t* are transparent with regard to the combination of the meaning *end* and the conceptual content of the inflectional affixes. He claims that one needs structures like the one in figure 1b because of this, and hence he has a structural paradox. Bierwisch (1987, p. 165) and Stiebels (1996, p. 46) suggest rebracketing mechanisms to derive the structure in figure 1a from the one in figure 1b. However, this paradox is not a real one, since the situation with idioms is similar as far as compositionality is concerned.¹ It is not justified that a head that is part of an idiomatic expression is combined with all parts of the idiom before it is inflected. So one can stick to the structure in figure 1a; assuming that the semantics of non-transparent particle verbs is constructed parallel to the semantics of idioms.

For transparent particle verb combinations I also assume the structure in figure 1a. I assume that the inflectional affix attaches to a stem that contains the information that it will combine with a particle, i.e., a stem that is subcategorized for a particle. This stem has the meaning of the complete particle verb combination although the exact meaning is not fully instantiated until the particle combines with the (inflected) stem. Since the semantic information that will be contributed by the particle is accessible in the stem entry already, the ending can scope over it.

2.2 Derivation

Similar bracketing paradoxes seem to arise in derivational morphology. Some derivational affixes are sensitive to the argument structure of the head they combine with and some others are sensitive to the semantics of the heads they combine with, some affixes

¹Bierwisch gives examples from compounding that suggest that rebracketing may be needed and, of course, there are famous examples of a similar kind from English; but for the cases at hand a rebracketing mechanism is not necessary as will be shown in section 3.1.

Stump (1991) discusses a wide variety of morphosemantic mismatches in English, Breton, Georgian, and Sanskrit and suggests paradigm functions that allow inflectional or derivational material to attach to a head that is contained inside of other material, i.e., he assumes a structure like figure 1b. On page 714 he remarks that in derivational paradigms in which the derived member belongs to a syntactic category distinct from that of the base member, the derived member generally fails to allow this kind of structure where the inflectional or derivational material attaches to the head. He remarks that nouns derived from particle verbs are exceptions (*hang on* → *hanger on*, *pass by* → *passer-by*). With my analysis particle verbs can be analyzed without a paradox and therefore they do not constitute an exception to his generalization. I will discuss his approach in section 4.2.

are sensitive for both kinds of properties. In sections 2.2.1 and 2.2.2, I will examine the relevant forms of nominalization and adjective formation.

2.2.1 *Ge- -e-Nominalizations*

The *Ge- -e*-nominalization is the only discontinuous or combinatorial noun derivation in German, consisting of the prefix *Ge-* and the suffix *-e*. *Ge- -e*-derivation is quite productive for transitive as well as for intransitive simplex verbs. Deverbal *Ge- -e*-nouns have the meaning of ‘to V constantly/repeatedly’ and usually they have the connotation that the constant V-ing is unpleasant.

Particle verbs also allow for *Ge- -e*-derivation. It is interesting that the *ge-* separates particle and base verb: *Herumgerenne* (‘repeated aimless running’). *Ge- -e*-nominalizations of particle verbs with the particle *herum* (‘around’) follow a productive pattern and are quite frequent.

As Lüdeling (2001, p. 106) notes, the interesting thing about these *Ge- -e*-nominalizations is that there again seems to be a bracketing paradox: If one combines the stem *renn-* with *Ge-* and *-e* one gets *Gerenne*, which means ‘repeated or constant running’, or more technically ‘repeated running events’. However, *Herumgerenne* means ‘repeated instances of aimless running events’. The ‘aimless’ part of the meaning is contributed by *herum*. This meaning of *Herumgerenne* would be expected if the *Ge- -e* were combined with the whole particle verb combination.

Lüdeling considers for a moment the introduction of an abstract predicate for the form of *rennen*, but dismisses this suggestion since, according to her, this solution would not extend to listed particle verb combinations. I do not understand this argumentation, since the non-transparent forms are always the unproblematic ones in terms of scope relations. The particle verb selects the particle and the complete semantics is represented at the entry of the verb. Lüdeling suggests the analysis in figure 2b. It

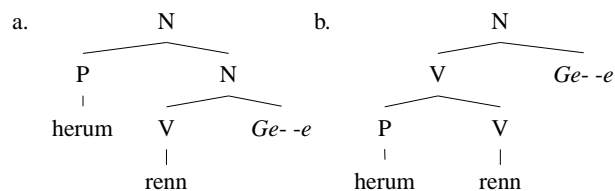

Figure 2: Alternative Structures for *Herumgerenne*

is unclear how the prefix *ge-* is supposed to get in-between the particle and the verb without the assumption of rebracketing. In what follows I will assume the structure in figure 2a. I assume that the stem *renn-* that is used to derive *Herumgerenne* already contains the information that it combines with a particle, although the exact semantic and syntactic contribution of the particle is still underspecified. The *Ge- -e*-nominalization can therefore access the semantic contribution that will be instantiated by the particle and the right scope relations can be established.

2.2.2 Adjective Derivation with *-bar*

-bar-derivation applies to transitive or ditransitive verbs that have an accusative object. The logical subject of the verb is suppressed and the accusative object is promoted to the subject of the adjective. There are also a few *-bar*-adjectives like *brennbar* ('flammable') that have an intransitive base verb, but these are listed in the lexicon Riehemann (1998a) and not derived by the productive rules. The *-bar*-suffix adds a modal meaning, usually possibility, but sometimes also necessity.

Particle verb combinations that are the result of a productive process can take part in *-bar*-derivations as is shown by (1).

- (1) Die Geschäfte müssen *anfahrbar* bleiben.
 the shops must PART (to).drivable remain
 'The shops must remain accessible by car.'

The particle *an* combines with intransitive verbs and licenses an additional argument.

- (2) a. Er fährt.
 he drives
 b. *Er fährt die Geschäfte.
 he drives the shops
 c. Er fährt die Geschäfte an.
 he drives the shops towards
 'He drives towards the shops.'

As (2b) shows *die Geschäfte* is not an argument of the base verb *fährt*. This NP is licenced in the particle verb construction only. The pattern is productive.

This seems to result in another bracketing paradox: There are particles that only combine with intransitive verbs and add another argument. On the other hand, *-bar* combines only with transitive verbs productively. If one assumes the structure in figure 3a with *fahr-* being the stem of the intransitive version of *fahren* one has to explain why *-bar* can combine with intransitive verbs. Furthermore the modal operator that is contributed by *-bar* scopes over the complete meaning of the particle verb. In the light of pairs like (3), the structure in figure 3a seems implausible, since there is no way of deriving the meaning of the second word from the meaning of the first:

- (3) a. *schaffbar* ('do-able') → *wegschaffbar* ('possible to be got rid of', 'disposable')
 b. *greifbar* ('reachable') → *angreifbar* ('possible to be attacked')
 c. *stellbar* ('possible to stand/set up') → *darstellbar* ('possible to be represented', 'representable'), *einstellbar* ('possible to set', 'employable'), *herstellbar* ('possible to manufacture'), *vorstellbar* ('imaginable')

Even worse, a *bar*-adjective without particle does not exist for the examples in (4).

- (4) a. **guckbar* → *anguckbar* ('possible to look at')²

²(Bierwisch, 1987, p. 163)

- b. * *gleichbar* → *ausgleichbar* ('possible to even out')
- c. * *weisbar* → *nachweisbar* ('possible to prove')

At first glance figure 3b seems to be the only option. For reasons of uniformity I will assume the structure in figure 3a. While at first glance this may seem to be problematic

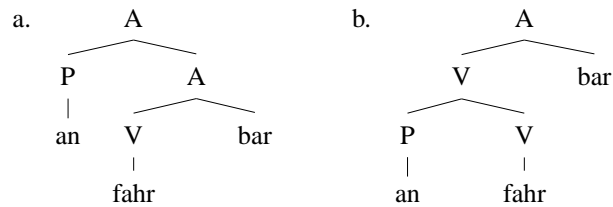

Figure 3: Alternative Structures for *anfahrbar* ('reachable by car')

for the reasons mentioned above, it is not in constraint-based theories. I assume that the stem in figure 3a contains a slot for the particle that will be added in a later step. The valence and the semantics of the whole combination is represented at the stem so that *-bar* may access it.

3 The Analysis

In (Müller, 2000a,b, To Appear) I discussed constituent order data that showed that particles behave like other elements that take part in predicate complex formation (verbal complexes, subject and object predicative constructions, and resultative constructions).³ I therefore suggested a complex predicate analysis that uses argument attraction techniques which were introduced into the HPSG framework by Hinrichs and Nakazawa (1989). I followed (Chung, 1993; Rentier, 1994; Müller, 1997), who suggested using a separate valence feature for the selection of dependents that are part of the predicate complex. So particles are selected by their head via the valence feature *VCOMP*. Verbs that can function as heads in productive particle verb combinations are licensed by the following lexical rule:

³Tilman Höhle suggested using the same rule for the combination of particle and verb as for the verbal complex in his 1976 dissertation. The chapter of his dissertation that deals with this issue was published as Höhle (1982). Höhle deals mainly with morphological problems. The syntactic properties of the particle verb constructions are not explored in detail.

(5) Lexical Rule for Productive Particle Verb Combinations:

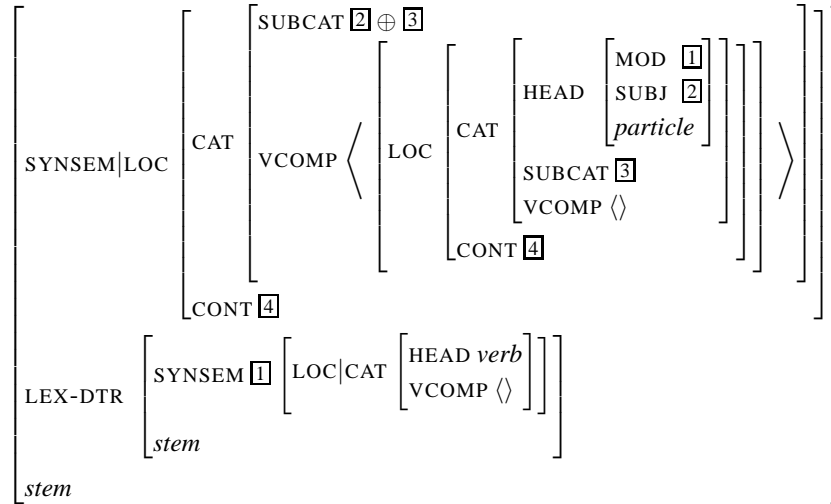

The rule applies to all verbs with an empty VCOMP value. The output of the rule is a verb that selects a particle. Whether the resulting verb is actually used in an analysis depends on the presence of a particle that can be combined with this verb. The valence requirements of the output verb are determined by the particle: The SUBCAT and SUBJ⁴ value of the particle attracted by the output verb. The rule licenses verbal stems that select particles that modify the base verb semantically. This is indicated by the structure sharing of the MOD value of the particle and the SYNSEM value of the input verb ([1]).⁵

Particles like *los* in *losrennen* ('start to run') and *an* in *anfahren* ('drive towards sthg.')

(6) *los* (aspectual marker):

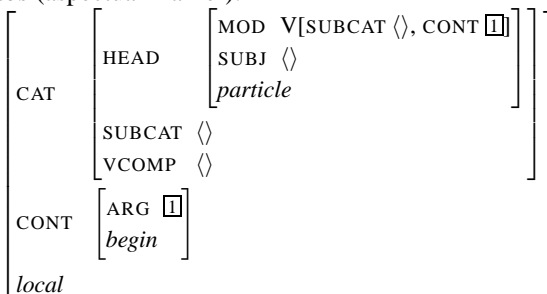

This particle modifies an intransitive verb (SUBCAT = $\langle \rangle$) and encapsulates the semantics of this verb ([1]) under the relation it contributes (*begin*). When lexical items that are licensed by the lexical rule in (5) are combined with the particle, they take the semantic contribution from the particle. This is ensured by the structure sharing [4] in (5).

⁴I follow (1992; 1995) in assuming that SUBJ is a head feature.

⁵This rule is in a certain way similar to the adjunct introduction lexical rule that van Noord and Bouma (1994) use: An adjunct is introduced into a valence feature list.

As an example, consider what happens, if the lexical rule applies to the entry of the base verb *rennen* ('to run').

(7) *renn-* ('run'):

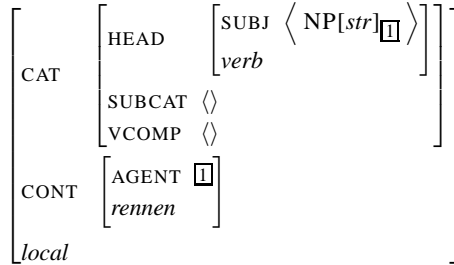

The result is shown in (8). This entry has to be inflected in order to be usable in syntax. Instead of undergoing inflectional rules, (8) may be input to derivational rules.

(8) *renn-* ('run' + subcategorized for particle):

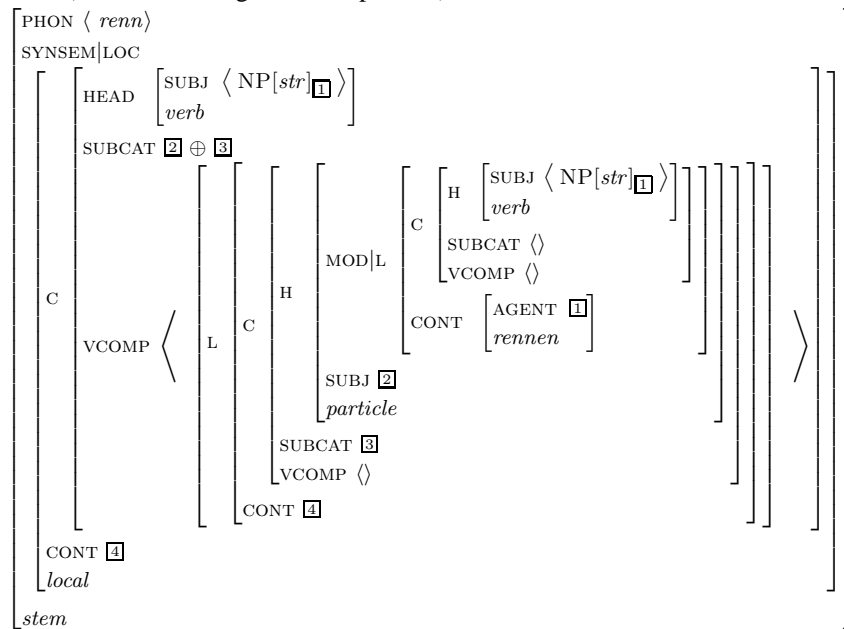

In the following I will use the entry in (8) to explain the syntactic combination of particle and verb. When the inflected form of the entry in (8) is combined with the particle in (6), the structure under CAT|VCOMP gets instantiated in the following way:

(9) *rennen* ('run' + particle *los* result of the unification in VCOMP):

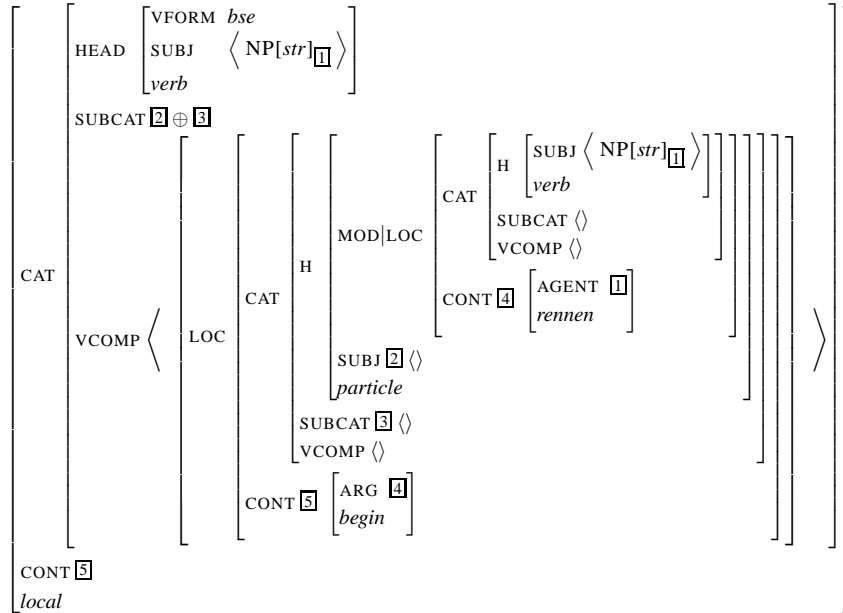

The information that was added by the particle is the structure sharing [4] between the semantics of the original base verb that was the input to the lexical rule (5) and the argument of the relation contributed by the particle. The semantics of the combination of *rennen* and *los* is taken from the adjunct ([5]) and is also represented as the semantics of the complete combination. The SUBJ value of *los* is raised to the SUBCAT list of *rennen*. Since *los* does not have a subject, the combination of *los* and *rennen* remains intransitive. The result of combining the particle with the verb is shown in (10).

(10) *rennen* ('run' + Particle *los*):

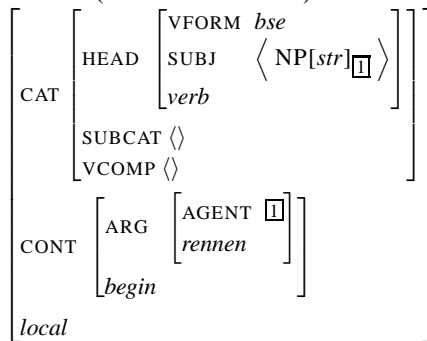

If one combines (8) with the *an* that is used in *anfahren* instead of *los* one gets a different result, since the lexical entry of this *an* differs from the entry for *los* in that it has an element on SUBJ and therefore introduces an additional element to the SUBCAT list of the verb it combines with.

3.1 Morphology

There are two basic approaches to inflectional and derivational morphology. The first is called “Item-and-Arrangement (IA) approach”, “Morpheme-based approach”, or “Word Syntax approach”. It is assumed that words consist of morphemes that are form meaning pairs. Such morphemes are combined in a way that is similar to what is known from syntax. The alternative proposal is called “Item-and-Process (IP) approach”. Here it is assumed that stems are related to other stems or to words by realizational rules. Affixes are not elements of the lexicon. The phonological material that is contributed by an affix in the Item-and-Arrangement model is introduced in the process that derives a form from a given stem. For a comparison of the two approaches see (Hockett, 1954) and (Anderson, 1988).

As an example consider the inflected form *fragt* (‘asks’) which consists of the stem *frag-* and the ending *-t*. In a morpheme-based approach both the stem and the ending are morphemes and it is assumed that both bear meaning. The word *fragt* has the structure *frag + t*. In a Item-and-Process approach there is no lexical entry for *-t*. Instead the form *fragt* is licensed by a process that relates the stem to the fully inflected word (*frag* ⇒ *fragt*). The information that *t* is an appropriate ending for the present tense is contained in the definition of the relation that relates the stem to the word.

In the HPSG paradigm both Item-and-Arrangement and Item-and-Process analyses have been developed: Trost (1991), Krieger and Nerbonne (1993), Krieger (1994), van Eynde (1994, Chapter 4), and Lebeth (1994) suggest an affix-based approach and Pollard and Sag (1987, Chapter 8.2), Orgun (1996); Riehemann (1998b); Ackerman and Webelhuth (1998); Kathol (1999), Koenig (1999)),⁶ use lexical rules that relate stems to other stems or words.

One advantage of the IP view is that one does not have to stipulate zero morphemes for cases of zero inflection or conversion. Another advantage is that the stipulation of subtractive morphemes is not necessary. Hockett (1954, p. 224) discusses cases from Chinese and French where a shorter form is regarded as derived from a longer more basic one (*bon* vs. *bonne* is the French example). A morpheme-based analysis would have to stipulate an abstract entity that has some meaning, but no phonological form. If it is combined with some other element, phonological material of this element is deleted. In the IP view on the other hand there is just a mapping from *bonne* to *bon* and the fact that something is deleted is encoded in this mapping. In what follows I therefore suggest a lexical rule-based analysis.

3.1.1 Inflection

The lexical rule in (11) is used to derive inflected lexical items from entries that are listed in the lexicon or that have been derived by other lexical rules that map uninflected lexical items to other uninflected lexical items. So it can be used to derive *rennst* from various forms of *renn-* (‘run’). One entry for *renn-* is the one that is listed. Another one is derived by the rule for productive particle verb combinations (see (5) on page 5), and can be used in sentences like *er rennt los* (‘he starts to run’).

⁶For non-HPSG-based approaches see for instance (Dowty, 1979, p. 304; Stump, 1991; Aronoff, 1994).

(11) Lexical rule for the 2nd person singular, present:

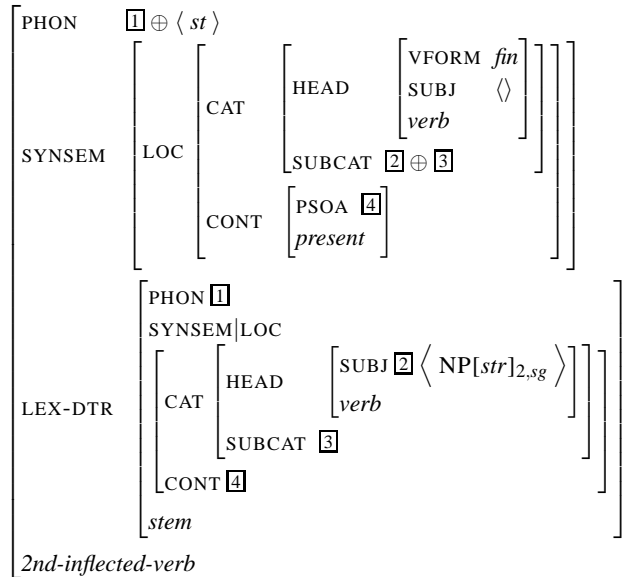

This lexical rule produces a finite form from the stem that may be basic or derived. The VFORM value is instantiated appropriately and since I follow Borsley (1989) and Pollard (1996) in assuming that subjects of finite verbs are represented on the SUBCAT list, the subject of the uninflected stem is appended at the beginning of the list of other arguments. The meaning of the input (4) is embedded under the *present* relation.⁷ The agreement information is directly represented at the subject. The rule in (11) is a subtype of the general Subject Insertion Lexical Rule (SILR). For other forms of the inflectional paradigm there will be other subtypes that add other phonological information to the stem and that enforce different agreement features on the subject. For subjectless verbs and verbs with clausal subjects there is a version of the rule above that adds a third person singular ending to the phonology value of the stem.

The two lexems for *renn-* that were mentioned above cannot be used in syntax since they are of the wrong type: they are not subtypes of *word*, only the output of lexical rules for inflection is.

If the rule in (11) is applied to the listed entry for *renn-* in (7), one gets (12).

⁷This representation of tense is a simplification. It can be replaced by a more appropriate analysis. See (Sag and Wasow, 1999) for a representation using Minimal Recursion Semantics (MRS).

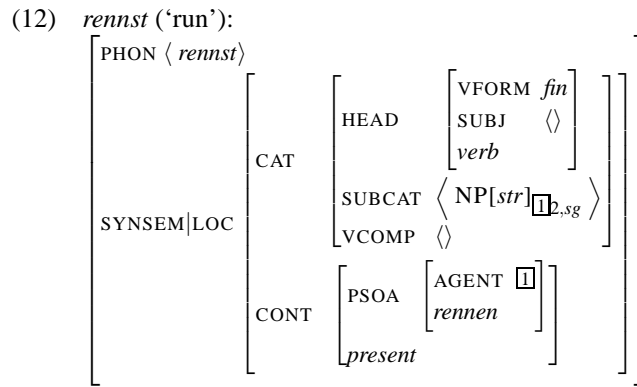

The result of applying the rule to the derived entry for the particle verb combinations with *renn-* in (8) is shown in (13).

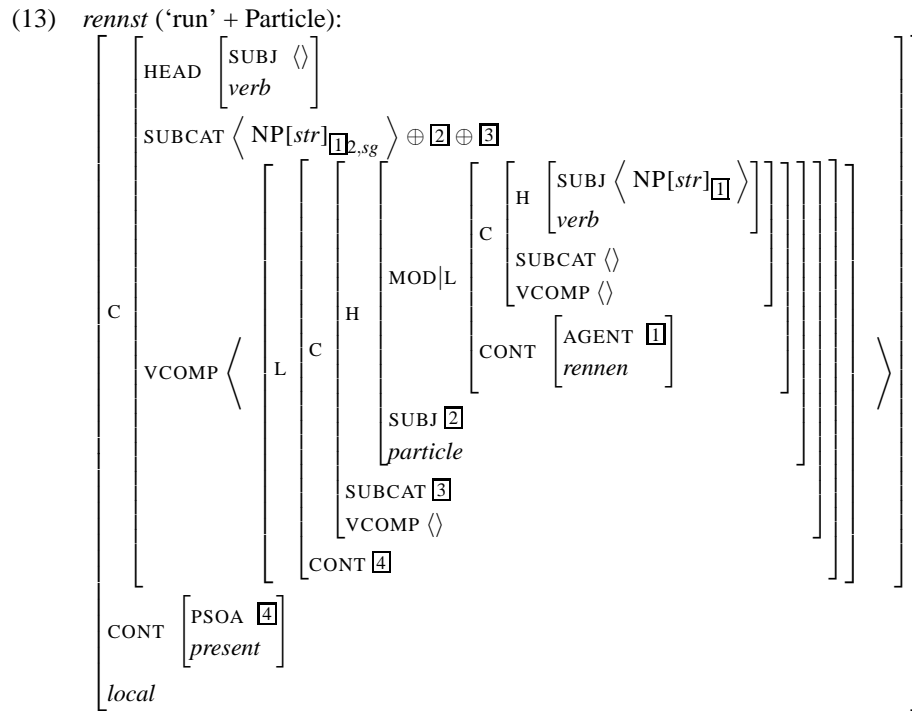

Although the semantics of the particle verb combination (4) is still underspecified since the particle is not combined with the verb yet, it can be referred to. The content of the particle that will be filled in later is embedded under the tense relation. When the particle *los* is combined with the lexical sign in (13), we get (14).

(14) *los rennst* ('run' + Particle *los* combination):

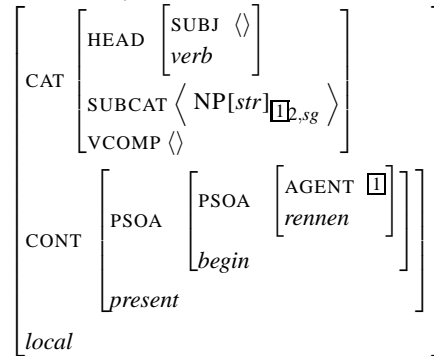

The combination of particle and verb is licensed by the predicate complex schema Müller (2000a,b).

3.1.2 *Ge-*-nominalizations

The lexical rule in (15) can be used to derive nominalizations like *Herumgerenne*.⁸

(15) Lexical rule for *Ge-*-nominalizations:

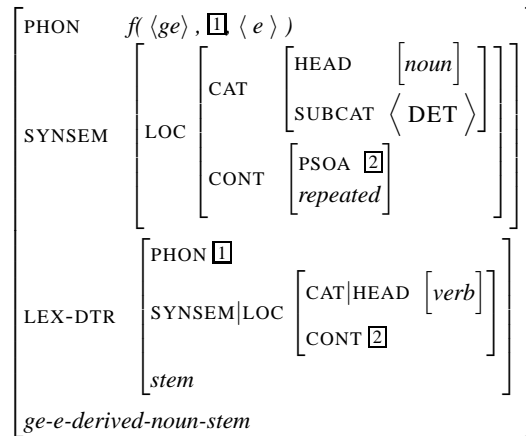

Consider first *Gerenne* as it can be derived from the lexical item in (7) for the verb *renn-* without a particle. If this lexical item is fed into (15), the result is (16).

⁸I ignore the possibility to realize arguments of the verb. I assume an NP analysis, but nothing hinges on that.

(16) *Gerenne-* ('repeated running'):

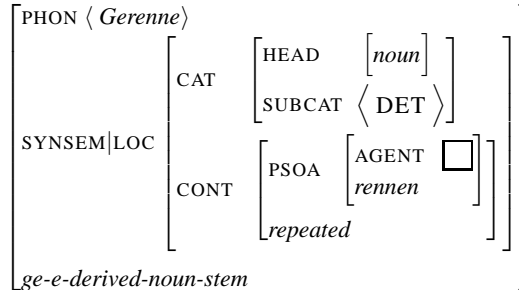

The agent of *rennen* is not specified in (16). The nominalization rule has to take care of the existential quantification of this argument.

To derive *Herumgerenne* we first have to apply the lexical rule (5) for productive particle verb combinations to the entry for *renn-* that is listed in the lexicon. The result was given as (8). The lexical rule for *Ge-* *-e*-nominalization applies to (8) and licences (17).

(17) *gerenne-* ('repeated running' + Particle):

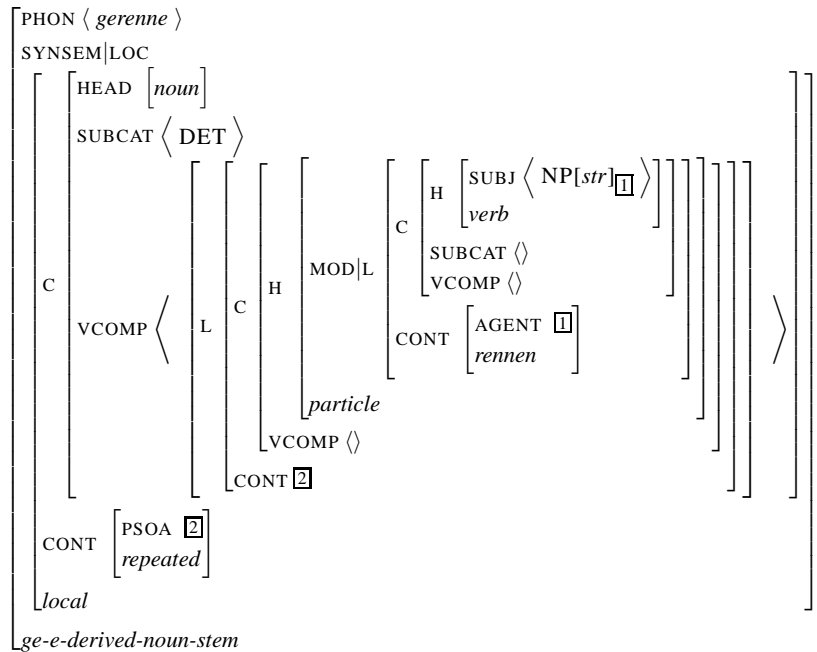

The semantics of *rennen* + particle (2) is the argument of *repeated*. In (17) the actual value is still underspecified, but when (17) is combined with the particle, (4) gets instantiated.

herum like *los* attaches to intransitive verbs only.

- (18) a. Karl rennt / hüpfte herum.
 Karl runs jumps around
 b. Karl liest (in dem Buch) herum.
 Karl reads in the book around
 c. *Karl liest das Buch herum.
 Karl reads the book around

There are several meanings of *herum*. I will call the one that is of interest here *herum*₁. *herum*₁ adds a component to the meaning of the input lexical entry that the action is aimless.

(19) *herum* ('around'):

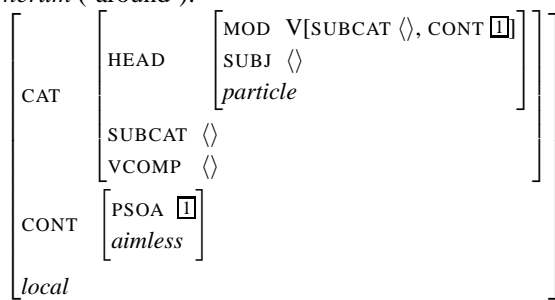

The result of combining the particle *herum* in (19) with (17) is shown in (20).

(20) *Herumgerenne*-:

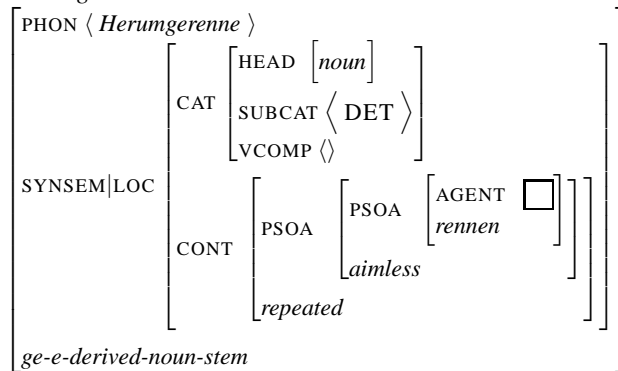

As with the simple *Gerenne* in (16), the agent of *rennen* is not specified in (20). The nominalization rule takes care of the existential quantification of this argument. The scoping of particle and derivational material in (20) is correct and no rebracketing mechanism is necessary.

3.2 -bar-derivation

Having dealt with inflection and with *Ge-* *-e*-nominalization, it is easy to see how *-bar*-derivation might work: A lexical rule licences a verb entry that can be combined with a particle. Arguments that are introduced by this particle are attracted by the lexical head

of the particle verb combination. Since this attraction is encoded in the lexical item for the head already, the *-bar*-derivation may refer to the argument that is contributed by the particle when the derived adjective is combined with the particle. Because of the constraint contributed by the *-bar* that there has to be an object, *-bar*-derivation does not apply to intransitive particle verbs.

4 Alternatives

In the next section I discuss two alternative proposals to solve the alleged bracketing paradoxes: The first one was suggested by Stiebels and Wunderlich (1994) and uses Williams (1981) notion of lexical relatedness. The second is Stump's analysis (1991) of morphosemantic mismatches that uses paradigm functions.

4.1 Rebracketing and Lexical Relatedness

Stiebels and Wunderlich (1994, p. 935) and Stiebels (1996, Chapter 3.2.1) assume the structure in (21) for nominalizations like *Einführung* ('introduction').

(21) [ein [[führ]_V ung]_N]

They assume a notion of lexical relatedness that is similar to the one that was proposed by Williams (1981):

(22) *Lexical relatedness:*

A compound of the structure [P [α V β]_X], where X is a noun or adjective formed from a verb (with α, β as possible derivation affixes), may be interpreted as if α, β were applied to the respective verb [P V]. α and β may be (phonologically) empty.

As they note, this principle violates strict compositionality: They assume that *Führung* ('leadership'), *Gabe* ('gift') and *sehbar* ('watchable')⁹ are parts of the words *Einführung* ('introduction'), *Abgabe* ('delivery'), and *absehbar* ('conceivable').

Stiebels and Wunderlich argue that such a postponed interpretation is needed for other cases of compounds too, since *Aufsteher* ('riser') is ungrammatical and *Frühaufsteher* ('early.riser') is grammatical.

-er-nominalizations are used to refer to a certain discourse referent in a situation. Since *to get up* is not a property that discriminates between people, the noun *Aufsteher* ('up-getter', 'riser') as such is strange. Lüdeling (2001, p. 101) provides a context where the property of getting up discriminates between people and therefore can be used without further specification: The situation is a hospital where a certain group of patients is allowed to get up during the day while the others have to stay in bed. In this situation it is possible to refer to a member of the first group as *Aufsteher* ('person who gets up') and to a member of the second group as *Liegenbleiber* ('person who does not get up'). This shows that *Aufsteher* is not ungrammatical and therefore such examples

⁹*sehbar* is often discussed as an example for blocking. However, only the sense 'visible' is not available. The translation 'visible' that Stiebels and Wunderlich give for *sehbar* is not appropriate.

do not count as independent evidence for a postponed interpretation in Stiebels and Wunderlich's sense.

On page 939 they discuss the data in (23):

- (23) a. bieten \approx Gebot ('offer')
b. verbieten \approx Verbot ('forbid/ban')
c. anbieten \approx Angebot ('offer')
d. aufbieten \approx Aufgebot ('exert/exercion')

verbieten is a prefix verb and *anbieten* and *aufbieten* are particle verbs. The root noun related to *bieten* is *Bot*, which was subject to a prosodically triggered *ge*-prefixation in West Germanic. The prefixed root noun *Verbot* is listed and therefore the *ge*-prefixation does not apply. The nominalizations of particle verbs are formed with *Gebot*. Stiebels and Wunderlich conclude from this that *Angebot* and *Aufgebot* are compounds that are formed from *Gebot* and a preposition. However, the data is also compatible with the analysis presented in the previous chapter: The *ge*-prefixation applies to a stem that contains a representation of the particle in its valence lists. No lexical relatedness is needed.

That *leadership* has anything to do with *introduction* is highly implausible and any analysis that does not have to make such assumptions should be preferred over Stiebels and Wunderlich's. Furthermore, in their approach, not just the interpretation has to get postponed, but the evaluation of other constraints as well. Stiebels and Wunderlich do not have a solution to the problem of non-existent bases (see (Paul, 1920, p. 75)): To derive *Ausbreitung* ('spreading') they have to assume **Breitung* as part of the analysis. Apart from this it is not clear when the passivization should apply in *-bar*-derivations. In their view, the *-bar*-derivation applies to an intransitive verb and the particle is combined with the result later. Only then the additional argument that is introduced by the particle is available. As was discussed in the data section, *-bar*-derivation productively applies only to transitive verbs.

4.2 Paradigm Functions

Stump (1991) suggested so-called paradigm functions that relate stems to stems or stems to words (roots to roots and roots to words in his terminology). These functions may be defined in a way that allows inflectional or derivational material to attach to a head contained in a more complex structure. With such a definition he can account for Pesetsky's *unhappier* puzzle (?): In general the comparative suffix joins with short adjectives and does not attach to trisyllables, so a bracketing [[un-happy] er] is not possible since *unhappy* is trisyllabic. Because of the shortness constraint [un [happier]] is the only available structure, but semantically one needs the first structure. For this comparative formation Stump defines paradigm functions that attach the comparative ending to the head inside [un-happy]. As was mentioned in footnote 1 on page 2 he also allows combinations of derivational material with heads in complex structures. On page 714 he remarks that in derivational paradigms in which the derived member belongs to a syntactic category distinct from that of the base member, the derived member generally fails to allow this kind of structure where the inflectional or derivational

material attaches to the head. He remarks that nouns derived from particle verbs are exceptions (*hang on* → *hanger on*, *pass by* → *passer-by*). In section 3 I showed how similar German examples can be handled without violating Stump's generalization. For *-bar*-derivation one does not need [[an-fahr]-bar]. The account that was presented in the previous section has another advantage over Stump's proposal: It can deal with particle verbs like *eindosen* ('to tin') that are not derived from base verbs. A verb **dosen* does not exist. In the approach presented in the last section *eindosen* is derived from the noun *Dose* ('tin'). The result of the application of a lexical rule is a verbal stem that selects the particle *ein*. This stem has to be inflected. In Stump's approach the inflectional material could not attach to a HEAD since the category of *eindosen* (V) differs from *Dose* (N) and therefore *eindosen* is headless (see Stump's definition of head on page 681). This means that Stump's approach cannot provide a uniform treatment of inflection and derivation for all classes of particle verbs where the inflectional or derivational material attaches to the stem directly.

5 Conclusion

In this paper I developed a constraint-based analysis for the morphology of particle verbs in German that copes with the alleged bracketing paradoxes. Powerful devices like rebracketing are not needed.

For a more detailed discussion of data and alternative analyses see (Müller, 2000a).

Acknowledgements

I thank Berthold Crismann for discussion and comments on related work.

I gave talks about the morphology of German particle verbs in Tübingen at the Seminar für Sprachwissenschaft, in Stuttgart at the Institut für maschinelle Sprachverarbeitung (IMS), in Potsdam at the Institut für Linguistik/Allgemeine Sprachwissenschaft and at the HPSG'2001 conference in Trondheim. I thank Tübingen, Stuttgart, and Potsdam for the invitation and the audiences of all four talks for discussion.

The research carried out for this paper was supported by a research grant from the German Bundesministerium für Bildung, Wissenschaft, Forschung und Technologie (BMBF) to the DFKI project WHITEBOARD ("Multilevel Annotation for Dynamic Free Text Processing"), FKZ 01 IW 002.

The paper was completed at the Institut für Germanistische Sprachwissenschaft of the Friedrich Schiller University Jena.

References

- Ackerman, Farrell and Weibelhuth, Gert. 1998. *A Theory of Predicates*. CSLI Lecture Notes, No. 76, Stanford, California: CSLI Publications.
- Anderson, Stephen R. 1988. Morphological Theory. In Frederick J. Newmeyer (ed.),

- Linguistics: The Cambridge Survey / Vol. I: Linguistic Theory: Foundations*, pages 146–191, Cambridge: Cambridge University Press.
- Aronoff, Mark. 1994. *Morphology by Itself: Stems and Inflectional Classes*. Linguistic Inquiry Monographs, No. 22, Cambridge, Massachusetts/London, England: The MIT Press.
- Bierwisch, Manfred. 1987. A Structural Paradox in Lexical Knowledge. In Elke van der Meer and J. Hoffmann (eds.), *Knowledge Aided Information Processing*, pages 141–172, Amsterdam: Elsevier Science Publisher B.V. (North-Holland).
- Borsley, Robert D. 1989. An HPSG Approach to Welsh. *Journal of Linguistics* 25, 333–354.
- Chung, Chan. 1993. Korean Auxiliary Verb Constructions Without VP Nodes. In Susumo Kuno, Ik-Hwan Lee, John Whitman, Joan Maling, Young-Se Kang and Young joo Kim (eds.), *Proceedings of the 1993 Workshop on Korean Linguistics*, Harvard Studies in Korean Linguistics, No. 5, pages 274–286, Cambridge, Massachusetts: Harvard University, Department of Linguistics.
- Dowty, David R. 1979. *Word Meaning and Montague Grammar*. Synthese Language Library, No. 7, Dordrecht, Boston, London: D. Reidel Publishing Company.
- Hinrichs, Erhard W. and Nakazawa, Tsuneko. 1989. Subcategorization and VP Structure in German. In *Aspects of German VP Structure*, SfS-Report-01-93, Eberhard-Karls-Universität Tübingen.
- Hockett, Charles. 1954. Two Models of Grammatical Description. *Word* 10, 210–234.
- Höhle, Tilman N. 1982. Über Komposition und Derivation: zur Konstituentenstruktur von Wortbildungsprodukten im Deutschen. *Zeitschrift für Sprachwissenschaft* 1, 76–112.
- Kathol, Andreas. 1999. Agreement and the Syntax-Morphology Interface in HPSG. In Robert D. Levine and Georgia M. Green (eds.), *Studies in Contemporary Phrase Structure Grammar*, pages 223–274, Cambridge: Cambridge University Press.
- Kiss, Tibor. 1992. Variable Subkategorisierung. Eine Theorie unpersönlicher Einbettungen im Deutschen. *Linguistische Berichte* 140, 256–293.
- Kiss, Tibor. 1995. *Infinite Komplementation. Neue Studien zum deutschen Verbum infinitum*. Linguistische Arbeiten, No. 333, Tübingen: Max Niemeyer Verlag.
- Koenig, Jean-Pierre. 1999. *Lexical Relations*. Stanford Monographs in Linguistics, Stanford: CSLI Publications.
- Krieger, Hans-Ulrich. 1994. Derivation Without Lexical Rules. In C.J. Rupp, Michael A. Rosner and Rod L. Johnson (eds.), *Constraints, Language and Computation*, Computation in Cognitive Science, pages 277–313, London/San Diego/New York: Academic Press, a version of this paper is available as DFKI Research Report RR-93-27. Also published in: IDSIA Working Paper No. 5, Lugano, November 1991.

- Krieger, Hans-Ulrich and Nerbonne, John. 1993. Feature-Based Inheritance Networks for Computational Lexicons. In Ted Briscoe, Ann Copestake and Valeria de Paiva (eds.), *Inheritance, Defaults, and the Lexicon*, pages 90–136, Cambridge: Cambridge University Press.
- Lebeth, Kai. 1994. Morphosyntaktischer Strukturaufbau – Die Generierung komplexer Verben im HPSG-Lexikon eines Sprachproduktionssystems. Hamburger Arbeitspapiere zur Sprachproduktion – IV Arbeitspapier No. 16, Universität Hamburg, Fachbereich Informatik.
- Lüdeling, Anke. 2001. *On Particle Verbs and Similar Constructions in German*. Dissertations in Linguistics, Stanford: Center for the Study of Language and Information.
- Müller, Stefan. 1997. Yet another Paper about Partial Verb Phrase Fronting in German. Research Report RR-97-07, Deutsches Forschungszentrum für Künstliche Intelligenz, Saarbrücken, a shorter version appeared in *Proceedings of COLING 96*, pages 800–805. <http://www.dfki.de/~stefan/Pub/pvp.html>. 11.15.2001.
- Müller, Stefan. 2000a. *Complex Predicates: Verbal Complexes, Resultative Constructions, and Particle Verbs in German*. Habilitationsschrift, Universität des Saarlandes, Saarbrücken, <http://www.dfki.de/~stefan/Pub/complex.html>. 11.15.2001.
- Müller, Stefan. 2000b. German Particle Verbs and the Predicate Complex. In Ronnie Cann, Claire Grover and Philip Miller (eds.), *Grammatical Interfaces in HPSG*, Studies in Constraint-Based Lexicalism, No. 8, pages 215–229, Stanford: CSLI Publications, <http://www.dfki.de/~stefan/Pub/part-complex.html>. 11.15.2001.
- Müller, Stefan. To Appear. Syntax or Morphology: German Particle Verbs Revisited. In Nicole Dehé, Ray Jackendoff, Andrew McIntyre and Silke Urban (eds.), *Verb-Particle Explorations*, Interface Explorations, No. 1, Berlin, New York: Mouton de Gruyter, <http://www.dfki.de/~stefan/Pub/syn-morph-part.html>. 10.30.2001.
- Orgun, Cemil Orhan. 1996. *Sign-Based Morphology and Phonology*. Ph.D.thesis, University of California, Berkeley.
- Paul, Hermann. 1920. *Deutsche Grammatik. Teil V: Wortbildungslehre*, volume 5. Halle an der Saale: Max Niemeyer Verlag, 2nd unchanged edition 1968, Tübingen: Max Niemeyer Verlag.
- Pollard, Carl J. 1996. On Head Non-Movement. In Harry Bunt and Arthur van Horck (eds.), *Discontinuous Constituency*, Natural Language Processing, No. 6, pages 279–305, Berlin, New York: Mouton de Gruyter, published version of a Ms. dated January 1990.
- Pollard, Carl J. and Sag, Ivan A. 1987. *Information-Based Syntax and Semantics Volume 1 Fundamentals*. CSLI Lecture Notes, No. 13, Stanford: Center for the Study of Language and Information.

- Rentier, Gerrit. 1994. Dutch Cross Serial Dependencies in HPSG. In *Proceedings of COLING 94*, pages 818–822, Kyoto, Japan, <http://xxx.lanl.gov/abs/cmp-lg/9410016>. 04.07.99.
- Riehemann, Susanne Z. 1998a. Type-Based Derivational Morphology. *Journal of Comparative Germanic Linguistics* 2, 49–77.
- Riehemann, Susanne Z. 1998b. Type-Based Derivational Morphology. *Journal of Comparative Germanic Linguistics* 2, 49–77, <http://doors.stanford.edu/~sr/morphology.ps>. 11.05.2001.
- Sag, Ivan A. and Wasow, Thomas. 1999. *Syntactic Theory: A Formal Introduction*. Stanford: Center for the Study of Language and Information, <http://csli-publications.stanford.edu/site/1575861607.html>.
- Stiebels, Barbara. 1996. *Lexikalische Argumente und Adjunkte: Zum semantischen Beitrag verbaler Präfixe und Partikeln*. studia grammatica XXIX, Berlin: Akademie Verlag.
- Stiebels, Barbara and Wunderlich, Dieter. 1994. Morphology Feeds Syntax: the Case of Particle Verbs. *Linguistics* 32(6), 913–968.
- Stump, Gregory T. 1991. A Paradime-Based Theory of Morphosemantic Mismatches. *Language* 67(4), 675–725.
- Trost, Harald. 1991. Recognition and Generation of Word Forms for Natural Language Understanding Systems: Integrating Two-Level Morphology and Feature Unification. *Applied Artificial Intelligence* 5, 411–457.
- van Eynde, Frank. 1994. *Auxiliaries and Verbal Affixes—A Monostratal Cross-linguistic Analysis*. Katholieke Universiteit Leuven, Faculteit Letteren, Departement Linguïstiek, proefschrift.
- van Noord, Gertjan and Bouma, Gosse. 1994. The Scope of Adjuncts and the Processing of Lexical Rules. In *Proceedings of COLING 94*, pages 250–256, Kyoto Japan.
- Williams, Edwin. 1981. On the Notions “Lexically Related” and “Head of a Word”. *Linguistic Inquiry* 12(2), 245–274.