

A compositional and constraint-based approach to non-sentential utterances

David Schlangen 

University of Edinburgh

Alex Lascarides 

University of Edinburgh

Proceedings of the 10th International Conference on
Head-Driven Phrase Structure Grammar

Michigan State University

Stefan Müller (Editor)

2003

Stanford, CA: CSLI Publications

pages 380–390

Schlangen, David & Alex Lascarides. 2003. A compositional and constraint-based approach to non-sentential utterances. In Stefan Müller (ed.), *Proceedings of the 10th International Conference on Head-Driven Phrase Structure Grammar, Michigan State University*, 380–390. Stanford, CA: CSLI Publications. DOI: 10.21248/hpsg.2003.21. 

Abstract

We present an approach to the interpretation of non-sentential utterances like B's utterance in the following mini-dialogue: A: "Who came to the party?" B: "Peter." Such utterances pose several puzzles: they convey 'sentence-type' messages (propositions, questions or request) while being of non-sentential form; and they are constrained both semantically and syntactically by the context. We address these puzzles in our approach which is compositional, since we provide a formal semantics for such fragments independent of their context, and constraint-based because resolution is based on collecting contextual constraints.

1 Introduction

In the following examples, B's utterances are *non-sentential*, consisting only of phrases, possibly modified by an adverb:

- (1)
 - a. A: Who likes Peter?
 - b. B: Definitely he himself.
 - c. A: Peter came to the party.
 - d. B: Mary's cousin?
- (2)
 - a. A: What did he make you do?
 - b. B: Kill JFK.
 - c. A: What did he force you to do?
 - d. B: To kill JFK.
- (3)
 - a. A: On whom can we rely?
 - b. B: On Sandy.
 - c. A: Who did you see?
 - d. B: #On Sandy.
- (4)
 - a. A: Peter left very early.
 - b. B: Exams.

Such non-sentential utterances pose several puzzles. First, even though the utterances are non-sentential, their intended meaning is of semantic types typically associated with full sentences, such as propositions and questions. This content is partially determined by contextual information.

Second, as (Morgan 1973, Morgan 1989) pointed out, the computation of this intended meaning cannot always rely solely on semantic or pragmatic information: eg., the fragment (2-d) cannot felicitously be used to answer (2-a), even though presumably the semantic type of (2-d) is the same as that of (2-b). Similarly, the preposition in (3-b)—a verb particle—is normally considered to be semantically empty,¹ and hence is not represented in the semantics. However, (3-b) is not felicitous as an answer to the question (3-c).

¹Cf. eg. (Pollard & Sag 1994).

Third, the reconstruction cannot solely work on syntactic structure either. As (Ginzburg 1999) points out, examples like (1-b) are incompatible with a syntactic approach, since their likely reconstruct “definitely he himself likes Peter” is ungrammatical. To this kind of counter example (Barton 1990) adds examples like (4), where apparently additional information has to be inferred.

Hence, the evidence seems to be contradictory, at the same time favouring and opposing both syntactic and semantic approaches to resolution. In this paper we present a way out of this impasse. We offer an analysis of the syntax and compositional semantics of these utterances, couched in the framework of HPSG (Pollard & Sag 1994, Sag 1997). We briefly describe an implementation of this analysis in a wide-coverage HPSG, and evaluate the impact of adding these rules. We then describe how the HPSG-analysis interfaces with a theory of discourse interpretation, and how this theory can explain the puzzle, given limited access to syntactic information. Finally, we compare our approach to that of (Ginzburg & Sag 2001), who offer a radically unmodular approach where information from grammar and from discourse is not distinguished. We show that our approach has advantages both in terms of coverage (we can deal with examples like (4)) and also in theoretical terms. From this we draw some general conclusions about how interaction between grammars like HPSG and contextual interpretation is best modelled.

2 A grammar of fragments

2.1 The Analysis

Our grammatical analysis of fragments like that in the previous examples is relatively straightforward: we make the assumption that fragments are phrases,² possibly modified by adverbs. As (5) shows, only scopally modifying adverbs are allowed.

- (5) A: Who sang this song?
B: Maybe Sandy. / *Badly Sandy.

In a pseudo phrase-structure notation, the rules simply are of the form ‘S-frag → (ADV) XP’. We formalise this in a version of HPSG that allows *constructions* (Sag 1997), ie. phrase-types that make a semantic contribution. Unlike (Pollard & Sag 1994) we do not use situation semantics as the framework for our semantic representations but rather MRS (Copestake et al. 1999), which supports semantic underspecification (cf. (Reyle 1993)). We will say more about the semantics of this formalism below. For now we just note that MRS-representations consist of a feature INDEX whose value represents the semantic index of the sign; a feature LTOP that holds the *handle* of the sign, ie. a label for the bits of logical form introduced

²This goes back to (Morgan 1973); explicit rules can be found in (Barton 1990). We ignore for now more complicated examples like ‘A: Does John devour or nibble at his food? — B: Oh, John devours.’

by it; LZT, which is a bag of labelled *elementary predications* (EPS); and H-CONS, which collects constraints on the order of sub-formulae.

The formalisation is best explained with an example. Figure 1 shows, in a tree representation, the sign for the NP-fragment “Peter.” It shows how the NP is lifted to the level of sentences, and how the semantics of that sentence is composed.

Let’s work our way ‘top-down’ to describe this Figure in detail. The root-sign in this tree has all the syntactic features of a sentence: the value of its `SYNSEM.LOCAL.CAT` is of type *verb*, and all valence requirements are satisfied. It is also semantically like a sentence, in that its top-EP (with the handle $\boxed{2}$) is of type *message* (more precisely, a *prpstn*). This EP is contributed by the fragment-rule, via the feature `C-CONT` (construction content). In the same way an *unknown*-constraint is introduced, which is an anaphoric element expressing the underspecification in the content of fragments, as will be explained below. The connection of this constraint to the semantics of the phrase is made via co-indexation of the argument-slot of *unknown* with the `INDEX` of the argument phrase (in Figure 1 this is $\boxed{5}$).

As the type-declaration in Figure 1 shows, this sign is the combination of two types, namely *headed-phrase*, which is a general type that defines the features and co-indexations in headed phrases; and *np-nm-decl-frag*, which collects the specifications particular to fragments. This type in turn inherits from three further types: *np-frag*, which specifies the particularities of fragments consisting of NPs; *nm-frag*, which specifies non-modified fragments (ie., a phrase that is not modified by an adverb); and *decl-frag*, which indicates that the fragments resolves to a proposition. These three types encapsulate properties of fragments that can vary independently, and build the hierarchy shown in Figure 2.

We assume a generalised head-feature principle (*ghfp*) as in (Ginzburg & Sag 2001) according to which all values for `SYNSEM`-features on the mother are by default token-identical to those of the daughter, and hence we have to make sure that the fragment-types override this default where appropriate. For example, the value for `SYNSEM.LOCAL` of fragments must be specified on the types for the fragments, since it will always be different from that of the head daughter—raising different XPs to sentences after all is the whole point of the rule, and so the default of the *ghfp* to copy these specifications must be overridden. The value of `SYNSEM.LOCAL.CAT` will be the same for all types of fragments, namely that of a sentence. In fact, the only elements of the type instantiated in Figure 1 that are specific to NP-fragments are the co-indexation of the `INDEX` of the head (the NP) with the `ARG` of the *unknown*-rel, and the restriction that the phrase be an NP. So the constraint unique to NP-fragments (ie., the specification of the type *np-frag*) is simply that shown in (6).

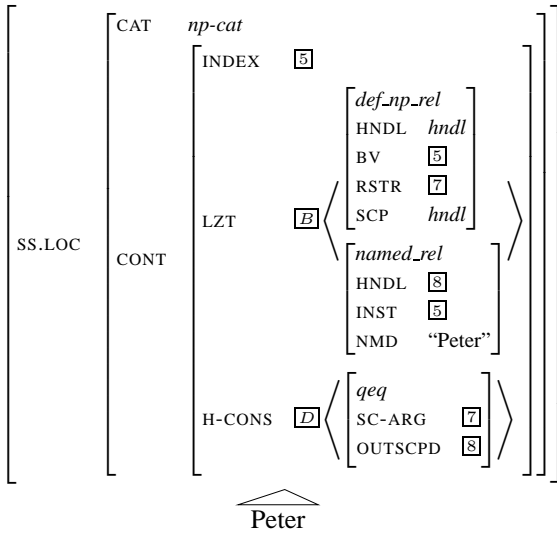
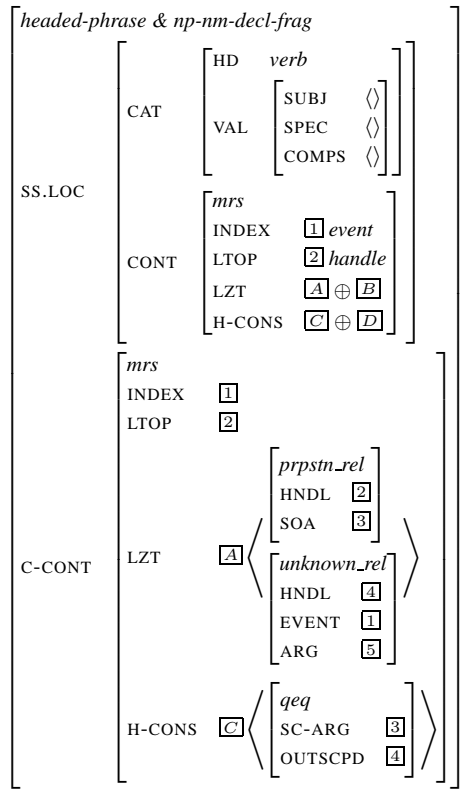

Figure 1: "Peter" as a declarative fragment.

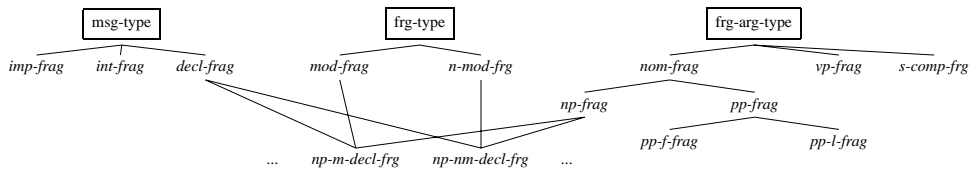

Figure 2: An extract of the construction hierarchy for fragments

$$(6) \quad \begin{array}{l} \text{np-frag:} \\ \left[\text{C-CONT.LZT} \left\langle [\quad], [\text{ARG } \boxed{1}] \right\rangle \right] \end{array} \rightarrow \begin{array}{l} \mathbf{H} \left[\text{SYNSEM.LOCAL} \left[\text{CAT} \left[\begin{array}{l} \text{HEAD } \textit{nominal} \\ \text{VAL} \left[\begin{array}{l} \text{COMPS } \langle \rangle \\ \text{SPR} \langle \rangle \end{array} \right] \end{array} \right] \right] \right] \\ \text{CONT.INDEX } \boxed{1} \end{array} \right] \end{array}$$

The example we have seen above is one of a non-modified fragment. In fragments that are modified by an adverb, we find an additional non-head-daughter, whose EP is scoped in as sister to the *unknown_rel*, as shown in (7).

$$(7) \quad \left[\begin{array}{l} \text{mod-frag} \\ \text{C-CONT} \left[\begin{array}{l} \text{mrs} \\ \text{LZT} \left\langle \begin{array}{l} \left[\begin{array}{l} \textit{prpstn_rel} \\ \text{HNDL } \boxed{2} \\ \text{SOA } \boxed{3} \end{array} \right] , \\ \left[\begin{array}{l} \textit{unknown_rel} \\ \text{HNDL } \boxed{4} \end{array} \right] \end{array} \right\rangle \\ \text{H-CONS} \left\langle \begin{array}{l} \left[\begin{array}{l} \textit{qeq} \\ \text{SC-ARG } \boxed{3} \\ \text{OUTSCPD } \boxed{4} \end{array} \right] , \\ \left[\begin{array}{l} \textit{qeq} \\ \text{SC-ARG } \boxed{3} \\ \text{OUTSCPD } \boxed{5} \end{array} \right] \end{array} \right\rangle \\ \text{NON-HEAD-DTRS} \left\langle \left[\text{SYNSEM} \left[\begin{array}{l} \textit{scopal_vp_adv} \\ \text{LOCAL.CONT.TOP } \boxed{5} \end{array} \right] \right] \right\rangle \end{array} \right] \end{array} \right]$$

Finally, the last dimension organises the differences in the type of message to which the fragment will resolve. The example we have seen in Figure 1 was one of a propositional-fragment; fragmental questions or requests only differ in the type of this topmost-relation. To give an example, (8) shows the type *int(errogative)-frag(ment)*.

$$(8) \quad \left[\begin{array}{l} \textit{int-frag} \\ \text{C-CONT.LZT} \left\langle [\textit{int}], \dots \right\rangle \end{array} \right]$$

<i>Version of Grammar</i>	<i>Average # parses</i>
LinGO ERG, 20/11/02	2.86
ERG+frag	3.69

Table 1: Competence comparison of the original ERG with the fragment-ERG

The rules in this dimension also make sure that *wh*-phrases can only be *int*-frags.

This concludes our brief presentation of our syntactic analysis of fragments, for more details see (Schlangen & Lascarides 2003) or (Schlangen 2003).

2.2 Implementation

We have implemented our analysis in a wide-coverage HPSG, the *English Resource Grammar* (ERG, see for example (Copestake & Flickinger 2000));³ the implementation was evaluated using the grammar-profiling tool [`incr tsdb()`] (Open & Flickinger 1998). First, to test for possible adverse effects on the analyses of full-sentences, we ran a batch-parse of a test-suite of full sentences, the CSLI-test-suite which is distributed with [`incr tsdb()`]. It consists of 1348 sentences, of which 961 are marked as syntactically well-formed and 387 as ill-formed. Table 1 shows a comparison of the original ERG with our extended version containing the fragment rules, with respect to the average number of parses per sentence.

As these data show, the fragments rules do introduce some new ambiguity, but on average less than one more parse per item. We conclude from this that adding these fragment-rules doesn't lead to an explosion of readings that would render the grammar practically unusable. What this evaluation doesn't tell us, however, is whether the additional readings (of what is meant to be full sentences) are erroneous or not. The problem is that 'fragmenthood' is not a syntactic criterion, and so some strings that can be analysed as sentences can also be analysed as fragments. (E.g., (2-b) above is both an imperative sentence and a VP-fragment.)

To test the coverage of our extended grammar with regards to fragments, we manually marked up all fragments in a corpus of dialogue examples (from the Verbmobil-project, cf. (Wahlster 2000)). In 4037 items we identified 369 fragments, of which our grammar correctly parsed 242 (= 65.5%). A detailed study of the fragments that were not recognised showed that a useful extension would be rules for handling fragments of the form "CONJ XP", eg. "and on Saturday."; including those would bring our coverage up to 82.6% of the corpus.

³The implementation differs slightly from the analysis described in the previous section: the ERG doesn't make use of defaults, and so we had to explicitly state what is identical between mother and daughter and what isn't.

3 Semantics and Resolution

As mentioned above, the basic element of our compositional semantics of fragments is the relation *unknown_rel*. In a different notation, the compositional semantics we gave for the fragment “Peter” in Figure 1 is as shown in (9).

$$(9) \quad \langle h, e, \{ h:prpstn_rel(h_1), h_2:unknown_rel(e, x), \\ h_6:def_np_rel(x, h_8, h_9), \\ h_{10}:named(x, Peter) \}, \\ \{ h_1 =_q h_2, h_8 =_q h_{10} \} \rangle$$

This formula expresses that all we know about the meaning of the fragment *independent from its context* is that a) it will resolve to a proposition, of which b) the main predicate is unknown, but c) one participant in the main event of the proposition is specified, even though its exact role isn’t. For details of the formal semantics of this relation, please see (Schlangen 2003).⁴

These descriptions are augmented via a theory of discourse interpretation, SDRT (Asher & Lascarides 2003). This theory attempts “to enrich dynamic semantics with techniques for encoding the contribution of pragmatics” (Asher & Lascarides 2003, p.180). One central notion of dynamic semantics (eg. (Kamp & Reyle 1993)) is the update of a representation of the context with that of new information; in SDRT, this update is dependent on non-monotonic inferences over linguistic and non-linguistic information. SDRT’s update-operation is defined on descriptions like MRSS; it simply adds constraints on the form of logical forms. The inferred information that is most important for us is the *speech act type* that connects the new information to the context (for in SDRT speech acts are *relations*, to reflect the fact that the successful performance is logically dependent on the context). We only sketch the basic idea here, and refer the interested reader to (Schlangen 2003). The inferred speech act type determines the resolution of fragments, by adding further constraints to the description. For example, the information that (1-b) is an *answer* to (1-a) (we call the relation *QAP* for *question-answer-pair*) or that (4-b) offers an *Explanation* for (4-a) resolves in this approach the underspecification in the fragment.

One last element is missing in the explanation of the puzzles from Section 1. We make a distinction between fragments that are resolved by identifying certain elements from the context with the underspecified relation (as for example in complement questions: “Peter” as an answer to “Who came to the party?” is resolved via identifying a certain sub-formula of the question with the ‘missing’ content of the fragment) and fragments that are resolved via inference that possibly uses world-knowledge (as must be the case for (4)). We explain the puzzle by allowing *update* limited access to syntactic information when resolving the first kind of fragments; more specifically, the *update* is only coherent if the subcategorisation

⁴Note the similarity between the use of descriptions in the semantics to that of descriptions in HPSG: where we use MRSS to describe (possibly sets of) logical forms, HPSG uses attribute-value-matrices to describe (possibly sets of) feature structures.

requirements of the elements that take the fragment as argument are met. This explains the pattern in (2) and (3), while allowing (4) to be free of syntactic influence. For details on how this method can also explain the apparent syntactic constraints on fragments where optional elements are ‘filled’ by the fragment (as in “A: I made a purchase. — B: Another pair of shoes?”), please see (Schlangen 2003).

4 Related Work

As mentioned in the introduction, (Ginzburg & Sag 2001) (henceforth G&S) offer a non-modular approach to the resolution of short-answers (and some other fragmental speech acts). (10) shows a very schematic representation of their approach.

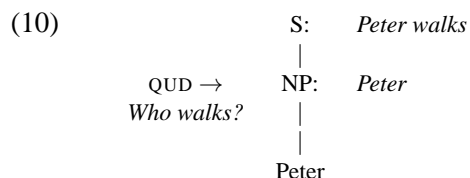

A grammar rule specific to the *use* made of the fragment (in (10) as an answer) directly projects NPs as sentences, with parts of the sentential content coming from a contextual feature QUD (question under discussion). This grammar rule in one go checks the syntactic constraints and constructs the intended content of the fragment.

In our view, our compositional approach has certain advantages. First, the grammatical analysis of fragments is uniform; contextual variation in their meaning is accounted for in the same way as it is for other anaphoric phenomena, via inferences underlying discourse update. This yields the second advantage: resolving fragments is fully integrated with resolving other kinds of underspecification (as described in detail in (Schlangen 2003)). Third, the interaction between grammar and pragmatics is straightforward: pragmatics enriches information coming from the grammar. In G&S’s approach the grammar has to ‘decide’ on the speech act that has been performed (the grammar-rules are specific for eg. answering, clarification); something that is normally seen to be a defeasible process. Hence, even in G&S’s approach a pragmatic module is required, which then has the task of filtering out unwanted parses. Fourth, we have available a strong theory of contextual interpretation which can explain the reasoning behind the resolution of examples like (4) (although we have not shown here in detail how); the functional application used by G&S seems too weak to do this. Fifth, our compositional approach allowed us to relatively straightforwardly extend an existing wide-coverage grammar; the requirement of the non-compositional approach to have available contextual information entails that standard parsers cannot be used without modifications. Finally, we think the use of the feature CONTEXT in G&S’s approach is problematic: since it is assumed to hold information about the context of the utterance, HPSG-signs can no longer be seen as representations of *types* of linguistic entities. Note that it

is not possible to view CONTEXT as a repository for restrictions on the *use* of the type modelled by the sign, as is done for example in the analysis of honorifics in HPSG, since for every possible fragment phrase there is an infinite number of ways the CONTEXT-feature can be specified (since the fragment can be for example an answer to an infinite number of questions).

5 Conclusions and Further Work

We have presented the outline of a compositional and constraint-based approach to non-sentential utterances. The basic elements of this approach are a grammar of fragments, which produces an underspecified semantic representation of their compositional semantics, ie. a representation of their content independent from their context. This representation consists of constraints that describe logical forms. As a third element we have shown how our approach interfaces with a theory of discourse interpretation, SDRT. We have briefly discussed why we think a compositional approach is advantageous.

As further work we plan to analyse the syntax and semantics of fragments that begin with conjunctions, e.g. “And Peter.” or “Or maybe on Sunday?”, which as we have shown are relatively frequent in dialogue corpora.

Acknowledgements

We would like to thank Viktor Tron and Chris Callison-Burch for comments on earlier versions of the paper, and also the reviewers and participants of HPSG03 for their helpful comments.

References

- Asher, N. & Lascarides, A. (2003), *Logics of Conversation*, Cambridge University Press.
- Barton, E. L. (1990), *Nonsentential Constituents*, John Benjamins, Amsterdam / Philadelphia.
- Copestake, A. & Flickinger, D. (2000), An open source grammar development environment and broad-coverage english grammar using HPSG, in ‘Proceedings of the 2nd Linguistic Resources and Evaluation Conference’, Athens, Greece, pp. 591–600.
- Copestake, A., Flickinger, D., Sag, I. & Pollard, C. (1999), Minimal recursion semantics: An introduction. Stanford University, Stanford, CA.
*<http://www-csli.stanford.edu/~aac/papers/newmrs.ps>
- Ginzburg, J. (1999), Semantically-based ellipsis resolution with syntactic presuppositions, in H. Bunt & R. Muskens, eds, ‘Computing Meaning: Current issues in computational semantics’, Kluwer, Dordrecht.
- Ginzburg, J. & Sag, I. A. (2001), *Interrogative Investigations: The Form, Meaning, and Use of English Interrogatives*, number 123 in ‘CSLI Lecture Notes’, CSLI Publications, Stanford.
- Kamp, H. & Reyle, U. (1993), *From Discourse to Logic*, Kluwer, Dordrecht.
- Morgan, J. L. (1973), Sentence fragments and the notion ‘sentence’, in ‘Issues in Linguistics: Essays in honour of Henry and Rene Kahane’, UIP, Urbana.

- Morgan, J. L. (1989), Sentence fragments revisited, in B. Music, R. Graczyk & C. Wiltshire, eds, 'Papers from the 25th regional meeting of the Chicago Linguistics Society Part Two: Parasession on Language in Context', Chicago, USA, pp. 228–241.
- Oepen, S. & Flickinger, D. P. (1998), 'Towards systematic grammar profiling: Test suite technology ten years after', *Journal of Computer Speech and Language: Special Issue on Evaluation* **12**(4), 411–437.
- Pollard, C. & Sag, I. (1994), *Head-Driven Phrase Structure Grammar*, CSLI / The University of Chicago Press, Chicago and London.
- Reyle, U. (1993), 'Dealing with ambiguities by underspecification: Construction, representation and deduction', *Journal of Semantics* **10**, 123–179.
- Sag, I. A. (1997), 'English relative clause constructions', *Journal of Linguistics* **33**(2), 431–484.
- Schlangen, D. (2003), A Coherence-Based Approach to the Interpretation of Non-Sentential Utterances in Dialogue, PhD thesis, School of Informatics, University of Edinburgh, Edinburgh, UK.
- Schlangen, D. & Lascarides, A. (2003), The interpretation of non-sentential utterances in dialogue, in A. Rudnicky, ed., 'Proceedings of the 4th SIGdial workshop on Discourse and Dialogue', Sapporo, Japan.
- Wahlster, W., ed. (2000), *Verbmobil: Foundations of Speech-to-Speech Translation*, Springer, Berlin.