

# Integrating pragmatic information in grammar: An analysis of intersentential ellipsis

Núria Bertomeu

Saarland University

Valia Kordoni 

Saarland University

Proceedings of the 12th International Conference on  
Head-Driven Phrase Structure Grammar

Department of Informatics, University of Lisbon

Stefan Müller (Editor)

2005

Stanford, CA: CSLI Publications

pages 49–69

Bertomeu, Núria & Valia Kordoni. 2005. Integrating pragmatic information in grammar: An analysis of intersentential ellipsis. In Stefan Müller (ed.), *Proceedings of the 12th International Conference on Head-Driven Phrase Structure Grammar, Department of Informatics, University of Lisbon*, 49–69. Stanford, CA: CSLI Publications. DOI: 10.21248/hpsg.2005.3. 

## Abstract

In this paper we present a proposal to integrate pragmatic information, both from the preceding discourse and the extra-linguistic context, in the grammar. We provide an analysis of elliptical fragments according to how they are anchored to the context and the kind of resolution they require. We also present an alternative view about the syntax of fragments.

## 1 Introduction

The minimal independent unit of meaning is a message containing an event/state state-of-affairs. In human communication meaning is usually expressed by linguistic means. However, often meaning is only expressed implicitly, that is, certain pieces of meaning are omitted and must be recovered from the context or even inferred. This is also the case for intersentential ellipsis, where the previous discourse usually provides the contextual anchor for the fragment and sometimes even tells us how to resolve it. But not seldom it is the communicative context which provides the contextual anchor for the fragment. Sometimes, even knowledge is required for the resolution.

The grammar explicitly defines what is a root sentence. Root sentences have as content a proposition with an illocutionary force relation which takes as argument a message, as proposed by Ginzburg et al. (2003). Elliptical fragments are also interpreted as performing a speech act over a message. They are, thus, root sentences. However, their content cannot be built up only with the content of its parts, that is, compositionally, but must be recovered from the context or be partially inferred. For this to be possible, fragments have to necessarily be uttered within the appropriate context. If this is not the case, they cannot be raised to the category of sentence and are mere constituents. Stand-alone constituents which cannot be raised to sentences are infelicitous, if not ungrammatical, since as argued above the minimal independent unit of meaning is the sentence. In our opinion grammar should define not only what is syntactically well-formed, but also what is semantically well-formed. In the case of fragments semantic well-formedness can only be defined with respect to the context and other pragmatic issues.

One of our aims in this paper is to present a grammar/pragmatics interface which allows us to place constraints on the use of stand-alone constituents. We propose a unified account of a wide range of fragments based on the notion of focus of attention. We present a new dimension for the classification of fragments based on the kind of resolution they require and on their anchoring to the context.

Another aim of this paper is to show, contrary to what previous approaches to the analysis of fragments claim, that the remnant/s is not the head-daughter of the fragment, and that this is phonetically empty. We will also claim, contrary to the established views too, that no constraint is needed for ensuring syntactic parallelism between the remnant of the fragment and some parallel element in the source. Furthermore, we argue that there is no such syntactic parallelism.

In the next section we will discuss previous approaches to the resolution of intersentential ellipsis and explain how our proposal differs from them. In section 3 we propose an alternative to the syntax of fragments. In section 4 we give a general overview of the overall architecture for discourse understanding/production in which our analysis of elliptical fragments is framed. In section 5 we present a proposal for the formalization and in section 6 we summarize and conclude.

## 2 Previous approaches to the resolution of fragments

In the present section we are discussing two previous approaches to the analysis of fragments in dialog proposed within the framework of HPSG (see Pollard and Sag (1994)).

### 2.1 The grammar-based approach

In Ginzburg and Sag (2001), a.o., an account of fragment resolution is proposed, which covers short answers, clarification requests and sluices. Our approach shares with it the view that the felicitous use of fragments must be constrained from within the grammar. However, in our opinion their analysis is not straightforwardly extendible to account for fragments lacking an explicit linguistic source, like in (1), since their resolution procedure takes only into account semantic structural information.

- (1) > Has Anastacia released any CDs in the last year?
  - Yes, "Left outside alone".
  - > Any prizes?

In this approach it is explicitly stated how a fragment should be resolved. This is achieved by structure-sharing of the  $\text{CONT(ENT)|SOA|NUCL}$  values of the  $\text{MAX(IMAL)-Q(UESTION)U(NDER)D(ISCUSSION)}$  and the mother of the fragment. The remnant of the fragment is its head-daughter and shares values for  $\text{CONT(ENT)}$  and  $\text{CAT(EGORY)}$  with the  $\text{SAL(IENT)-UTT(ERANCE)}$ , which has as value a singleton or empty set and is defined as the parallel element in the source.  $\text{MAX-QUD}$  has as value an object of type question whose value for the feature  $\text{PARAM(ETER)S}$  usually corresponds to the salient utterance. The Maximal Question under Discussion is defined as the issue currently being talked about. Every new utterance raises a Maximal Question under Discussion, which is the question at the top of the stack of  $\text{Q(UESTIONS)-U(NDER)-D(ISCUSSION)}$ .  $\text{QUD}^1$  determines the structure of the discourse and its stack behavior allows questions to become maximal once sub-questions depending on them have been resolved.  $\text{MAX-QUD}$  is taken to be the source upon which the fragment is resolved.

---

<sup>1</sup> $\text{QUD}$  is part of the DGB (Dialog Game-board) together with  $\text{FACTS}$ , a set of facts corresponding to the information taken for granted by the CPs, and  $\text{LATEST-MOVE}$ , the content of the latest move made, an illocutionary fact.

But the antecedent of a fragment doesn't always correspond to the Maximal Question under Discussion. This is not the case for genuine information-seeking elliptical questions, as the one shown in (2):

- (2) > How much is the new U2-CD?  
- 20 Euros.  
> And the one from 2Pac?  
"How much is the new 2Pac-CD?"

Ginzburg is aware of this and, having direct sluices in mind, states another place for holding antecedents, namely FACTS|TOPICAL (see Ginzburg (1997)). TOPICAL, concerns soas belonging to questions under discussion at that point in the dialog. Questions which get down-dated from QUD also get down-dated from TOPICAL. There is, however, a one move lag between the down-dating of questions from QUD and the disappearance of the addresses they provide in TOPICAL. However, in (2) the source doesn't fall under the definition of TOPICAL.

The theory assumes that a CP always tries to accommodate elliptical utterances as filling the abstracted slot in some question to which the fragment is a relevant answer given the current information state and according to some definition of question-answer relevance. Being able to resolve the fragment involves being able to accommodate a question. However, little is said about the reasoning involved in deciding which question is to be accommodated. Moreover, this question as well as the resolved fragment are represented at the semantic-structural level, however in examples like (3) we cannot have as the result of resolution a semantic-structural representation, since this would involve to choose a particular predicate for the relation in the soa, which would be an arbitrary decision.

- (3) - Einen Kaffee, bitte.  
A coffee<sub>acc.masc.sg.</sub>, bitte.  
'- A coffee, please.'

## 2.2 The coherence-based approach

Unlike in the previous approach, Schlangen (2003) considers the resolution process as something external to the grammar. The grammar gives us an analysis of the fragment which is underspecified for all the resolution possibilities. The remnant contributes to the compositional semantics of the fragment independently of what the resolved fragment turns out to be. The only information provided by the construction type licensing fragments is that the remnant is an argument or adjunct of an event unknown relation.

Schlangen explains within the framework SDRT (Asher & Lascarides, 1993, 2003) how the underspecified semantics of fragment is resolved in dialog. In SDRT rhetorical relations constrain where new information can attach, adopting the Right-Frontier Constraint<sup>2</sup>. Interpretation amounts to inferring rhetorical relations and maximizing discourse coherence, that is, defining a partial order on

<sup>2</sup>This issue is discussable. See Alcántara and Bertomeu (2005) for examples where this is not the case.

the resulting interpretations, the maximum of which will be the pragmatically preferred reading.

Schlangen distinguishes between two kinds of fragments: those which can be resolved via-identity, that is, where there is an explicit linguistic source sharing structural identity with the fragment, and upon which the fragment can be resolved; and those which have to be resolved via-inference, that is, when there is no linguistic source or only a partial one and some inference has to be done in order to resolve the fragment.

Most resolution via-identity is based on structural similarity between the source and the fragment. Saturation constraints ensure that there is a mapping between the focus-background partition of the source and the fragment. Each rhetorical relation involves a different saturation constraint. So fragment resolution amounts to inferring the rhetorical relation which holds between fragment and source and choosing the solution which maximizes the discourse coherence. Once a fragment-source pair is chosen substitution of the focused parts is carried out. But, if resolution via-identity is achieved in the end by substitution of structurally identical representations, why do we need to infer any rhetorical relations?

One of the problems of this approach is that the grammar doesn't constrain the use of fragments at all. Moreover, the output of the parser is a description which denotes an infinite set containing all the possible resolutions. To infer all possible relations and then rank them upon their coherence is a computationally costly process. We believe that in the parsing stage implausible interpretations are already ruled out. However, this is only possible if the grammar takes context into account and interfaces with other modules. Although the grammar cannot contain full information about how a fragment should be resolved because of uncertainty, it should restrict as much as possible the set of possible resolutions. In this sense, HPSG is an adequate framework to formalize this, since it allows to express constraints from the different linguistic levels in a single representation, including, thus, pragmatics.

### **3 The syntax of fragments**

#### **3.1 The head-daughter of fragments**

Both approaches discussed in the previous section consider that the remnant is the head-daughter of the fragment. The GHFP, which states that mother and daughter must share values for the feature HEAD by default, is, thus, overridden. This is, however, problematic when we want to account for fragments formed by more than one constituent independent from each other (gapping), like those shown in (4). Upon which reasons can we here decide which constituent is the head-daughter?

- (4) > When did 2-Pac release "All eyez on me"?
- > And Michael Jackson "Thriller"?

In Ginzburg and Sag (2001)'s approach the sole requirement that the salient utterance be the singleton or empty set already hinders an account of fragments presenting gapping.

Also in the psycholinguistic literature it has been claimed that the most psychologically plausible parsing mechanism is left-corner parsing, as stated in Crocker (1999). The human parser already begins building structure as soon as it encounters a new item. For fragments this would mean that the parser posits an empty head which is then semantically filled when resolving the fragment. This is less costly than analyzing the constituent provided in the fragment as the head and then reanalyzing when a sister or the real semantic head is encountered. From the point of view of the syntax-semantics interface it is also desirable that there is parallelism between the syntactic and semantic structures.

Unlike in previous approaches, in our analysis for fragments remnants will be non-head daughters, while the feature head-daughter will be phonetically empty. This approach is in the same line as the analysis of intra-sentential gapping proposed by Gregory and Lappin (1997), where the elliptical clause has a phonetically-null head-daughter and the remnants are, thus, non-head-daughters.

### 3.2 Syntactic parallelism

These two approaches share the view that the remnant must share some syntactic features with some parallel element in the source. Ginzburg and Sag (2001) account for this by constraining the values for the feature CAT of the salient utterance and the remnant of the fragment to be the same.

However, especially for adjuncts this is not always the case. Adjuncts can be propositional phrases, subordinated clauses and adverbs, and so it's not difficult to find parallel elements which differ in category like in the following example.

- (5) > How should I eat this?  
- With your hands. / As slowly as you can. / Enjoying it.

As pointed out by Schlangen (2003), one has to allow some degrees of freedom in what counts as the salient utterance, in order to account for the optionality of PP/NP in some fragments like the following:

- (6) > Where do you come from?  
- Germany. / From Germany.

To account for categorial congruence between source and fragment, Schlangen introduces a syntactic constraint. If the semantic constraints of a certain relation force a resolution that is semantically very close to an antecedent, then syntactic congruence is also demanded. If the syntactic parallelism is violated, the semantically close resolution cannot be the intended one.

However, we think that no such constraints requiring syntactic parallelism between the remnant and some parallel element in the source are required. Note that

optional arguments not present in the source are also subject to subcategorization requirements.

(7) Peter was reading when I saw him. A book about Montague semantics, I think.<sup>3</sup>

Syntactic parallelism seems to be just a consequence of the SUBCATEGORIZATION PRINCIPLE. In cases where resolution via-identity is required, a little extension of the SUBCATEGORIZATION PRINCIPLE in which it is stated that remnants must fulfill the subcategorization requirements of the predicate with which they are resolved would be enough to ensure the syntactic appropriateness of remnants.

The example in (3) from German shows that remnants must have certain syntactic features, be in a certain category and case, even when there is no explicit linguistic source and, thus, no parallel element. We don't think this kind of fragments must be resolved with a lexical predicate, since there are several possibilities and to choose a particular one would be arbitrary. They must be rather resolved with a much more general default predicate at the semantic-conceptual level.

Wierzbicka (1988) proposes that syntactic constructions and morphology have a semantics on their own. This is also true for category and case. A particular case can appear in a wide variety of constructions, but one can find a core meaning, a common theme which links all different constructions in which this case can appear.

Considering this, the only thing we need in order to ensure syntactic appropriateness of remnants without source is a principle similar to the SUBCATEGORIZATION PRINCIPLE, which states that remnants must be realized in the surface form corresponding to the semantics of the role they fill in the semantic-conceptual representation. Note that this requires a transparent interface between deep semantics and syntax.

#### **4 Overall architecture: context, knowledge and focus of attention<sup>4</sup>**

We will distinguish between two types of ellipsis resolution: *resolution via-identity* and *resolution via-inference*<sup>5</sup> and two levels of representation at which the resolution can take place: semantic-structural and semantic-conceptual. (2), (4) and (5) are typical examples of fragments which require *resolution via-identity*. (1) is an example of a fragment requiring *resolution via-inference*. The first type finds its antecedent in the previous source, however for the second type there seem to be two sources of context anchoring: the previous discourse and the surrounding physical environment<sup>6</sup>.

---

<sup>3</sup>This example is taken from Schlangen (2003).

<sup>4</sup>The discourse model presented here is part of Núria Bertomeu's PhD work.

<sup>5</sup>We will adopt the terminology proposed by Schlangen (2003).

<sup>6</sup>For empirical evidence on this see Alcántara and Bertomeu (2005).

## 4.1 Resolution at the semantic-structural level: the discourse-record

The discourse-record keeps track of the utterances performed. It is a memory buffer containing representations of the utterances in the order in which they have been uttered.

Surface and structural information rapidly decays from memory while semantic information remains for a longer time, see i.e. Kintsch and van Dijk (1978). This effect of decay of the surface representation of sentences from memory is reflected in our discourse-record. We will distinguish the following levels of utterance representation: phonological-positional (a serially-ordered, phonologically-specified string), functional or semantic-structural (an abstract linguistic representation with lexical-predicates and the assignment of their particular argument roles), semantic-conceptual (a deep semantic representation with conceptual predicates and the assignment of their particular argument roles), and meta-information about the utterance (the speech act performed with it and the speaker who contributed it). The phonological-positional representation is the first to be forgotten, followed by the functional representation. The other two levels remain longer in memory. As the discourse advances the representation of utterances may disappear from the memory buffer in a more or less first-in first-out fashion, although more important general issues may remain longer than more specific less important information. As discourse entities are introduced in the discourse they also enter a pool. In this pool there are no utterance representations as such, but representations of objects being talked about and part of the properties being assigned to them during the discourse as well as the inferences drawn on them. These objects are what in LuperFoy (1991) are called *pegs*. This accounts for the fact that after some time we don't remember exactly what we said in a conversation, but we remember the things we talked about.

Those sentences whose semantic-structural representation is still in the discourse-record are available as antecedents for ellipsis resolution via-identity at the semantic-structural level. We assume that at least the semantic-structural representation of the two previous utterances is retained. This accounts for follow-up questions like the one in (2).

## 4.2 Resolution at the semantic-conceptual level

There are cases of greater distances between fragment and source where we cannot consider that the semantic-structural representation of the source is still available in memory. Sometimes even there is no such explicit linguistic source. Ellipsis resolution, then, is carried out at the semantic-conceptual level.

### 4.2.1 Attention

Focus of attention can be understood as activation. Mental representations whose activation degree is over some threshold can be considered to be in focus of attention. There is a partial order of activation degrees. As the discourse advances a



common activation path is defined for all CPs<sup>7</sup>. When a speaker chooses to refer to something elliptically he believes that the hearer has his focus of attention placed in the same mental representation as he does and, thus, will be able to understand the utterance.

Recency is one of the factors influencing activeness, however goals and associated knowledge too. Ellipsis is a local phenomenon, so the source of ellipsis will be the most active representation in the focus of attention or else a representation whose structural semantics is still in memory. Of course, it can be the case that a sentence's structural-semantic representation is in memory and it is also in focus of attention. In such cases, the resolution will take place at the semantic-structural level of representation. It also can be the case that the semantic-structural representation of a sentence is still available in memory but it is not the thematic focus at that point in the dialog. In those cases we can still say that the representation is somehow active because it has been recently uttered, but it is not at the top of the focus of attention.

Our notion of top of the focus of attention will be thematic and will correspond to the things being talked about at a certain point in the conversation. There will be the following conceptual-semantic representations in the top of the focus of attention<sup>8</sup>:

- an open issue: the representation of an utterance whose associated goals have not been fully achieved, but whose achievement is a priority at that point.
- an issue which given the situation and task carried is the associated with a domain-relevant goal which has to be resolved at that point.
- a discourse-object recently uttered.
- an object in the communicative context.

#### 4.2.2 The action plan

An issue remains open if upon the goals of the CPs enough information about that issue has not yet been provided/obtained. Keeping track of the discourse goals of the CPs captures the activeness of certain utterances.

We agree with Carberry (1985) on the view that the discourse goals are necessary to keep track of issues under discussion<sup>9</sup>. Discourse goals take as arguments the semantic representations of issues. They are pushed into a stack. When goals are achieved, issues aren't any more under discussion, they can be hacked out as closed and they aren't any more accessible as sources for ellipsis unless their

---

<sup>7</sup>Of course, there can be divergences from this path, which cause misunderstandings.

<sup>8</sup>Ellipsis of representations which are not any more on the top of the focus of attention is also possible, but the utterer must provide some retrieval cue by repeating a part of the representation or pointing to the particular object.

<sup>9</sup>We don't agree with the view that understanding ellipsis always requires complex inferences on the task-related goals of the speaker. As we will explain below the knowledge base already allows us to interpret fragments which presuppose some knowledge of the world.

semantic-structural representation is still in the memory buffer. This allows to simulate the stack behavior of QUD in a memory buffer without needing any extra data-structure for utterances which aren't any more under discussion but which are still accessible as sources for ellipsis.

For example, before some question is posed the utterer has the goal: `obtain information` which leads him to carry out the action `ask question`. Once the question is posed the addressee's goal will be `answer question`, a subgoal of it can be `provide information`. If he needs extra information to answer the question his goals will be `obtain information` and the subsequent `ask question`. A possible goal also can be `reject question` if he doesn't want to discuss the issue, which can be achieved by saying it explicitly or by changing the topic. If he chooses one of the first two alternatives the question will be open until he achieves `answer question`. When this happens the utterer of the question will have achieved `obtain information` and the issue will be closed<sup>10</sup>. If the question is rejected it will be closed immediately. Examples like (8) are accounted for in this way:

- (8) > How long do you want to keep the movie?
- Is it closed on Sunday?
- > Yes.
- Then, until Monday.

### 4.2.3 Knowledge

Each CPs has a knowledge-base whose intersection are the Shared Beliefs. The communicative context as well as the information exchanged during the dialog are also part of the Shared Beliefs.

We agree with LuperFoy (1991) in the view that the information exchanged during the interaction must be kept separated from the rest of information in the knowledge base. There are several reasons for that. First of all, one may choose not to incorporate certain asserted propositions into his set of beliefs. And second, one needs to ground conceptually what is being talked about and make inferences on it upon the knowledge base, but one must still be able to distinguish what has been said during the discourse and what not. Keeping track conceptually of what has been said creates expectations about further utterances and decides on their interpretation. In our model this is accounted for in a straightforward way, since, as we will see, the entities in our discourse pool are the same kind of objects as those in the knowledge base. We assume that the objects in the discourse pool have a pointer to the corresponding objects in the knowledge-base, which makes all the facts holding of them available for inference.

The knowledge-base contains general knowledge of the world, domain knowledge and situational scripts. The communicative context is part of the knowledge

---

<sup>10</sup>This corresponds to the update/downdate of QUD in the grammar-based approach.

of the world. The knowledge is represented like a network where concepts and entities are linked to each other through relations.

We distinguish three kinds of fragments whose contextual dependence is in the knowledge-base (discourse pool, physical environment and the proper knowledge-base) and which may depend on the knowledge base for their resolution:

- when there is some salient entity in the pool of discourse entities about which the fragment says something or to which the remnant stands in some kind of relation upon the knowledge base (see (1));
- when there is some salient entity or action in the communicative context about which the fragment says something or to which the fragment stands in some kind of relation upon the knowledge base;

(9) Looking at a necklace: "So nice! How much?"

(10) Two persons in a room, one is hanging a picture on the wall, the other says: "Higher." (Hang) it higher.

- script-like situations: when the fragment has to be resolved with a salient issue provided by the communicative context and its associated goals upon the knowledge-base.

(11) Uttered by a customer at the travel agency: "Flights to Paris".

We can present a uniform account of this kind of fragments. In the first two cases we have to do with some semantic-conceptual representation, whose origin may be in the discourse or in the environment, which is in focus of attention and, thus, can be omitted. Further knowledge from the knowledge base allows to do the necessary inferences to resolve the fragment. In the third case it is the situational environment which activates some script in the knowledge-base, in which it is stated which goal associated with which issue the CPs pursues at that point. The issue associated with the goal is, thus, in focus of attention and can be elided. Since both representations of the contextual anchors and of the objects in the proper knowledge-base are mental representations, no interface problems arise. The linguistic input, the fragments themselves, are translated into semantic-conceptual representations and the result of the resolution is, of course, a semantic-conceptual (mental) representation.

## 5 Analysis and formalization

To formalize our notion of context dependency we will introduce two sub-features into the feature C(ON)T(E)XT: DISC(OURSE)-REC(ORD) and FOC(US-OF)-ATT(ENTION). We will also adopt the feature B(A)CKGR(OUN)D, proposed by Green (1996), with some modifications.

The feature DISC-REC will have as value a list of *ms(a)g(e)-sem(antic)-obj(ect)s*, a subtype of *sem(antic)-obj(ect)*. Figure 1 shows the hierarchy of *sem(antic)-obj(ect)s* with their feature-values specifications.

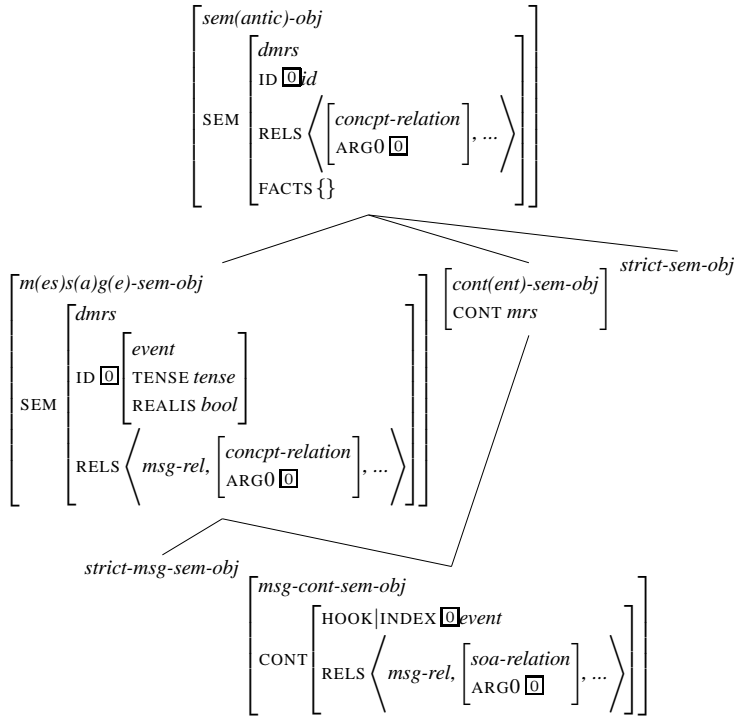

Figure 1: Type hierarchy of semantic objects

A d(eep)-mrs is a semantic-conceptual representation. We will express them in mrs-like format, but one has to keep in mind that there is no lexical or structural information in them. They are thoughts or mental representations of entities or events/states. The value of the feature ID(ENTIFIER) is similar to an index in a linguistic representation, but here it points to some individual/event in the knowledge sphere of the CP. The value for the feature REL(ATION)S is not a lexical predicate, but a conceptual predicate and the value of ARG0 is the entity which this predicate instantiates. The value of the feature FACTS is a possibly empty set of facts which hold of the semantic object in the knowledge base. If some utterance is grounded it means that it is matched against the knowledge base and all the facts holding of it and of the entities referred to in it are available for inference. *Sem-objs* is underspecified for semantic representations of entities/events in the knowledge-base, included those in the discourse pool and the situational environment, and representations of utterances in the discourse record. We have a subtype *strict-sem-obj* to designate those objects which are non-linguistic, i.e. those in SIT-OBJs.

The subtype *msg-sem-obj* is further specified to have as member of RELS a message relation and an ID of type event. This type corresponds to a full event/state mental representation. This kind of representations are the ones we have in the discourse-record when the structural form of the sentences is lost. This type has a further subtype *strict-msg-sem-obj*, about which we will say more when we talk

about open issues.

*Sem-cont-objs* have an additional feature CONT which has as value a semantic-structural representation and are, thus, still linguistic objects. The objects in the discourse pool which haven't lost their structural-lexical information will be of this type.

Finally, to the type *msg-cont-sem-obj* will belong the representations of recent utterances in the discourse-record which haven't lost their structural information yet. So the discourse-record will contain an ordered list of objects of the type *msg-sem-obj*, which is underspecified for semantic-conceptual representations and semantic-structural representations of sentences. The representation of older sentences will be a *msg-sem-obj*, not defined for the feature CONT, and newer sentences will be objects of the type *msg-cont-sem-obj*, which it is specified for the feature CONT.

The feature B(A)CKGR(OUN)D, as proposed by Green (1996), contains a set of true propositions which have to hold in the intersection of the beliefs systems of the CPs for a certain utterance to be pragmatically felicitous. The objects in BCKGRD are also of the type *sem-obj*. Within BCKGRD we will have two features for the dynamical sub-sets of the knowledge base, DISC(OURSE)-OBJ(ECT)S and SIT(UATIONAL)-OBJ(ECT)S. The first one will correspond to the pool of discourse objects. The value of DISC-OBJs will be a set of entities of the types *sem-obj* and *sem-cont-obj*, if they have been uttered recently. SIT-OBJs, on the other hand, contains a set of *strict-sem-objs* which are objects and actions in the communicative context and have no linguistic form. It also includes contextual indices. So we don't adopt the feature C-INDICES, and take its value to be part of our SIT-OBJs. The feature FACTS contains a set of pointers to the soas of the facts in BCKGRD which are available once the semantic-objects are matched against the knowledge-base.

DISC-REC, SIT-OBJs and DISC-OBJs contain the linguistic/mental representations in the context, to which the fragment can be anchored and which can be omitted.

The feature FOC-ATT will take, thus, as value an ordered list of *sem-objs* and fragments will be felicitous if their source, contextual anchor or some associated semantic-object upon the knowledge-base is the first element in the list. Fragments are also felicitous if there is a *msg-cont-sem-obj* in DISC-REC upon which they can be resolved.

## 5.1 Fragment analysis

We present a new dimension in the classification of fragments, **res(olution)-type**, based on their anchorage to the context and resolution type. We assume that this dimension will cross with the dimensions **msg-type** (with sub-types for the different types of messages), **frag-type** (distinguishing between modified and non-modified fragments) and **frag-arg-type** (with sub-types for the different syntactic categories of remnants and their function within the resolved sentence) similar to the ones

proposed in Schlangen (2003). The upper types in the four dimensions inherit from the general type *frag(ment)-cl(ause)*, whose specification is shown below. The hierarchy of fragment types in our dimension is shown in Figure 2.

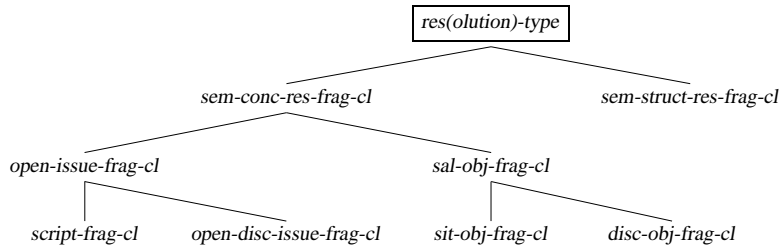

Figure 2: The **res-type** dimension

The general type *frag(ment)-cl(ause)*, which contains general specifications about the syntax and deep semantics of fragments and from which the types in the four dimensions inherit has the specification shown in (12). We introduce a new feature SEM in the sign, which stands for its semantic-conceptual representation<sup>11</sup>. What this supertype says is that there is a NON-HEAD-DTR which is linguistically realized, hence the specification for the feature SYNSEM. The type contributes a message and a soa-relation to the semantic-conceptual representation of the sentence. The mother, that is, the resolved fragment, is represented also at the semantic-conceptual level and has as value for the feature ID an event and for the feature RELS the relation contributed by the NON-HEAD-DTR and the relations contributed by C-SEM (a feature analogous to C-CONT in MRS).

$$(12) \left[ \begin{array}{l} \text{frag-cl} \\ \text{SEM} \left[ \begin{array}{l} \text{dmrs} \\ \text{ID} \quad \boxed{\text{event}} \\ \text{RELS} \quad \boxed{A} \oplus \boxed{B} \end{array} \right] \\ \text{C-SEM} \left[ \begin{array}{l} \text{dmrs} \\ \text{RELS} \quad \boxed{A} \left\langle \text{msg}, \left[ \begin{array}{l} \text{soa} \\ \text{RELN } \textit{soa-relation} \\ \text{ARG0} \quad \boxed{\text{event}} \end{array} \right] \dots \right\rangle \end{array} \right] \\ \text{NON-HEAD-DTRS} \left\langle \left[ \begin{array}{l} \text{sign} \\ \text{SYNSEM } \textit{synsem} \\ \text{SEM|RELS} \quad \boxed{B} \end{array} \right] \right\rangle \end{array} \right]$$

The sub-type *sem(antic)-struct(ural)-res(olution)-frag-cl* is further specified at the semantic-structural level as shown in (13). The mother gets the REL(ATIONS)S

<sup>11</sup>SEM is at the same level like SYNSEM because we assume that all signs have a meaning, however their surface realization may differ. Linguistic signs will be specified for the feature SYNSEM, but non-linguistic signs will be specified for a surface realization in a different modality. This is a first step towards having a unique format for the representation of the different modality signs which are employed in human communication.

and H(ANDLE)-CONS(TRAINTS) from the construction constraints and from the non-head-daughter. The G(LOBAL-)TOP has the same value as the label on an elementary predicate containing the message type and this, in turn, has as value for the feature SOA a handle which is *geq*<sup>12</sup> with the label of a soa, whose index, in turn, is the main index of the sentence. The feature CTXT contains a sub-feature DISC-REC which has as value a structural semantic-object of type *msg-cont-sem-obj* containing one elementary predicate, a soa-relation. We use the feature REL(ATIO)N as in Pollard and Sag (1994) and co-index the values of it for the soa-relation and the elementary predicate in the antecedent. We choose to represent the relation with a feature instead of being the type of the elementary predicate because this allows to say that both relations are of the same type, but without saying that they are the same event and have the same arguments.

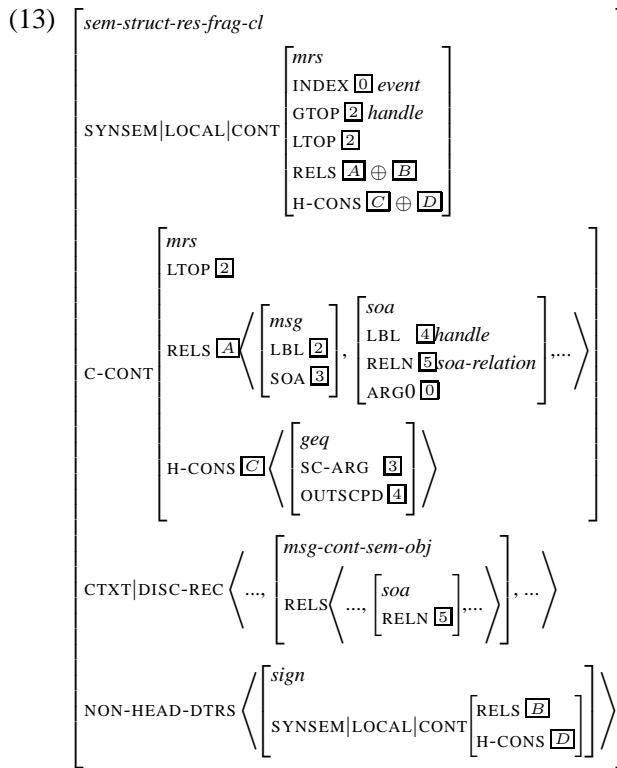

The other type of fragments that we have are resolved upon some representation in the focus of attention. The specification for the type *sem(antic)-conc(eptual)-res(olution)-frag-cl* is shown in (14). This supertype says that there is some object of type *sem-obj* in focus of attention whose value for RELS as well as the value for RELS of the remnant are shuffled with each other and belong to the RELS value of the mother together with the RELS provided by C-SEM.

<sup>12</sup>Greater or equal. See Schlangen (2003).

$$\begin{array}{l}
(14) \left[ \begin{array}{l}
\text{sem-conc-res-frag-cl} \\
\text{SEM} \left[ \begin{array}{l}
\text{dmrs} \\
\text{ID} \quad \boxed{0} \text{ event} \\
\text{RELS} \quad \boxed{A} \oplus \boxed{D} \text{ (where } \boxed{D} = \boxed{E} \oplus \boxed{B} \text{)}
\end{array} \right] \\
\text{C-SEM} \left[ \begin{array}{l}
\text{dmrs} \\
\text{RELS} \quad \boxed{A} \left\langle \text{msg}, \left[ \begin{array}{l}
\text{soa} \\
\text{RELN } \text{soa-relation} \\
\text{ARG0 } \boxed{0}
\end{array} \right] \dots \right\rangle
\end{array} \right] \\
\text{CTXT|FOC-ATT} \left\langle \left[ \begin{array}{l}
\text{sem-obj} \\
\text{SEM|RELS } \boxed{E}
\end{array} \right] \right\rangle \\
\text{NON-HEAD-DTRS} \left\langle \left[ \begin{array}{l}
\text{sign} \\
\text{SYNSEM } \text{synsem} \\
\text{SEM|RELS } \boxed{E}
\end{array} \right] \right\rangle
\end{array} \right] \\
\\
(15) \left[ \begin{array}{l}
\text{open-issue-frag-cl} \\
\text{SEM} \left[ \begin{array}{l}
\text{dmrs} \\
\text{ID} \quad \boxed{0} \text{ event} \\
\text{RELS} \quad \boxed{A} \oplus \boxed{D} \text{ (where } \boxed{D} = \boxed{E} \oplus \boxed{B} \wedge (\boxed{E} \equiv \boxed{F}) \text{)}
\end{array} \right] \\
\text{C-SEM} \left[ \begin{array}{l}
\text{dmrs} \\
\text{RELS} \quad \boxed{A} \left\langle \text{msg}, \boxed{F} \left[ \begin{array}{l}
\text{soa} \\
\text{RELN } \boxed{E} \text{soa-relation} \\
\text{ARG0 } \boxed{0}
\end{array} \right] \dots \right\rangle
\end{array} \right] \\
\text{CTXT|FOC-ATT} \left\langle \left[ \begin{array}{l}
\text{strict-msg-sem-obj} \\
\text{SEM|RELS} \left\langle \left[ \begin{array}{l}
\text{question-m-rel} \\
\text{PARAMS } \{ \boxed{1} \} \\
\text{MARG } \boxed{6}
\end{array} \right] , \left[ \begin{array}{l}
\text{prpstn-m-rel} \\
\text{ARG0 } \boxed{6} \\
\text{MARG } \boxed{0}
\end{array} \right] , \boxed{E} \left[ \begin{array}{l}
\text{soa} \\
\text{RELN } \boxed{E} \\
\text{ARG0 } \boxed{0}
\end{array} \right] , \dots \right\rangle
\end{array} \right] \\
\text{NON-HEAD-DTRS} \left\langle \left[ \begin{array}{l}
\text{sign} \\
\text{SYNSEM } \text{synsem} \\
\text{SEM} \left[ \begin{array}{l}
\text{ID } \boxed{1} \\
\text{RELS } \boxed{E}
\end{array} \right]
\end{array} \right] \right\rangle
\end{array} \right]
\end{array}
\end{array}$$

A sub-type of this type is the *open-issue-frag-cl*, shown in (15), which will account for open questions which have been overtly expressed in the discourse, more general open issues of discussion, and issues which are relevant in the current situation. The type *open-issue-frag-cl* is specified to have a *strict-msg-sem-obj*, concretely a question, in the focus of attention. We have chosen the type *strict-msg-sem-obj* as the value of FOC-ATT because we want to prevent fragments whose semantic-structural representation is still in memory to resolve in this way<sup>13</sup>. The remnant corresponds to the abstract parameter in the question and the question provides the soa-relation with which the fragment is to be resolved. This is achieved by stating equivalence between the soa-relation in the question and the soa-relation

<sup>13</sup>However, we may add a further sub-type under *sem-struct-res-frag-cl* with a specification that both soa-rels, in DIS-REC and in C-CONT are equivalent. We leave this issue open for the moment.



provided by C-SEM. We adhere to the traditional analysis of questions, also adopted in Ginzburg and Sag (2001), in which a question contains a proposition<sup>14</sup>.

The further sub-type *open-disc(ourse)-issue-frag-cl* will add the specification that the question has been uttered in the preceding discourse. Resolution of the fragment is achieved via-identity. It will account for fragments like (8).

$$(16) \left[ \begin{array}{l} \textit{open-disc(ourse)-issue-frag-cl} \\ \text{CTXT} \left[ \begin{array}{l} \text{DISC-REC} \langle \dots, \boxed{7}, \dots \rangle \\ \text{FOC-ATT} \langle \boxed{7}, \dots \rangle \end{array} \right] \end{array} \right]$$

$$(17) \left[ \begin{array}{l} \textit{script-frag-cl} \\ \text{FOC-ATT} \langle \text{SEM|RELS} \boxed{17} \rangle \\ \text{BCKGRD|SIT-OBJS} \left[ \begin{array}{l} \textit{sem-obj} \\ \text{SEM} \left[ \begin{array}{l} \text{ID} \boxed{10} \\ \text{RELS} \textit{utterance} \end{array} \right], \left[ \begin{array}{l} \textit{sem-obj} \\ \text{SEM} \left[ \begin{array}{l} \text{ID} \boxed{8} \\ \text{RELS|RELN} \textit{utterer} \end{array} \right], \left[ \begin{array}{l} \textit{sem-obj} \\ \text{SEM} \left[ \begin{array}{l} \text{ID} \boxed{6} \\ \text{RELS} | \text{RELN} \textit{addressee} \end{array} \right] \end{array} \right] \\ \textit{sem-obj} \\ \text{SEM} \left[ \begin{array}{l} \text{ID} \boxed{10} \\ \text{RELS} \left[ \begin{array}{l} \text{RELN} \boxed{10} \textit{location} \\ \text{ARG1} \boxed{0} \end{array} \right] \end{array} \right] \\ \text{FACTS} \left\{ \left[ \begin{array}{l} \textit{generic-soa} \\ \text{RELN} \textit{have} \\ \text{ARG1} \boxed{7} \oplus \boxed{7} \\ \text{ARG2} \boxed{7} \textit{goal} \\ \text{ARG3} \boxed{7} \end{array} \right] \wedge \left[ \begin{array}{l} \textit{generic-soa} \\ \text{RELN} \boxed{7} \\ \text{ARG1} \boxed{17} \end{array} \right], \dots \right\} \\ \textit{sem-obj} \\ \text{SEM} \left[ \begin{array}{l} \text{ID} \boxed{8} \\ \text{RELS|RELN} \boxed{7} \textit{rol1} \end{array} \right], \left[ \begin{array}{l} \textit{sem-obj} \\ \text{SEM} \left[ \begin{array}{l} \text{ID} \boxed{6} \\ \text{RELS|RELN} \boxed{7} \textit{rol2} \end{array} \right] \\ \text{FACTS} \left\{ \boxed{13} \wedge \boxed{14}, \dots \right\} \end{array} \right] \end{array} \right] \end{array} \right]$$

The subtype *script-frag-cl* will account for cases like in (3) and (11). What these fragments have in common is that they are uttered in situations in which the CPs are committed to a joint action. Each CP plays a different role and each role has associated with it different goals, but these goals are complementary<sup>15</sup>. This kind of tasks are prototypical and their associated action plan is part of our knowledge-base. Our approach is to state that the location of the interaction and the roles of the CPs in it, both semantic-objects in SIT-OBJS, activate some script in the knowledge base. This is formalized by means of the feature FACTS of the semantic

<sup>14</sup>In MRS question-relations do not contain a PARAMS feature, but a *which-rel* which has the same index as an abstract relation (*place-rel*, *person-rel*). Since our representation is a non-linguistic semantic representation we need this feature to express abstraction. We will also adopt the feature M(AIN)ARG(UMENT) which in MRS has as value a label, however here it will have as value the value of the ARG0 of the relation taken as argument, since we don't have labels. We think that at this level of representation we don't have scope ambiguities, so we don't need labels to underspecify these ambiguities.

<sup>15</sup>For example, in a shop the shop-assistant's goal is to sell something to the customer and the customer's goal is to buy something from the shop-assistant.

objects. This feature has as value a set of pointers to the soas of asserted facts in the knowledge-base. These soas are generic in the sense that they don't say anything about individuals, but about conceptual predicates. They are assertions about classes. If we take predicates to denote sets, then, the arguments of these generic-soas are all individuals which, upon the knowledge-base, are members of a certain set. In our analysis the arguments of generic-soas will be the values of the feature RELN. The location of the interaction and the roles of the CPs will have some facts associated with them which can be paraphrased as follows: "In such a location where the CPs play each a certain role the CPs will have at that point a common goal. This goal has as argument a certain semantic object". Goals exist respect to some semantic object. This semantic object corresponds in this case to a question which will be in focus of attention, since it is associated with the current goal of the CPs upon the knowledge-base. The goal itself will be a relation underspecified for the particular goals of the CPs, since, as explained before, each one has a particular goal corresponding to the role he plays, but these goals are complementary. The argument of their particular goals will be the same, that is, the question in focus of attention<sup>16</sup>. For the rest, this type behaves like its supertype *open-issue-frag-cl* and the remnant corresponds to the parameter, which depending on the role of the utterer, will be provided or asked for.

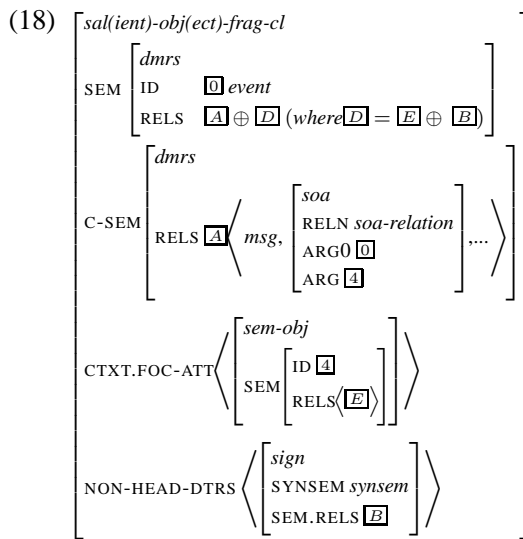

The type *sal(ient)-obj(ect)-frag-cl*, shown in (18), is a supertype which accounts for fragments which are contextually anchored to an entity, previously introduced in the discourse or present in the communicative context, to which the remnant stands in some kind of relation. Fragments like the ones in (1), (9) and (10) are accounted by sub-types of this type. Fragments like (1) can be resolved by inference upon the knowledge-base, as we will show below. However, fragments

<sup>16</sup>For example, in a taxi, the taxi-driver will have the goal obtain parameter(when to go?), while the customer will have the goal provide parameter(when to go?).

like (9) and (10), where the remnant provides an adjective predicated of the anchor or an adverb modifying the action in focus of attention, respectively, cannot be resolved like this. The type says that there is a semantic-object in the focus of attention which is an argument of the *soa*-relation with which the fragment is resolved. Both the relations of this semantic-object and of the remnant are part of the semantics of the mother, together with the semantics provided by C-SEM.

The sub-types *sit(uation)-obj(ect)-frag-cl* and *disc(ourse)-obj(ect)-frag-cl*, presented in (19), further specify the semantic-object in focus of attention to be an element of SIT-OBJS and to be of type *strict-sem-obj*, and an element of DISC-OBJS, respectively.

$$(19) \left[ \begin{array}{l} \textit{sit(uation)-obj(ect)-frag-cl} \\ \text{CTXT} \left[ \begin{array}{l} \text{FOC-ATT} \langle \boxed{6}, \dots \rangle \\ \text{SIT-OBJS} \{ \boxed{6}, \dots \} \end{array} \right] \end{array} \right] \quad \left[ \begin{array}{l} \textit{disc(ourse)-obj(ect)-frag-cl} \\ \text{CTXT} \left[ \begin{array}{l} \text{FOC-ATT} \langle \boxed{6}, \dots \rangle \\ \text{DISC-OBJS} \{ \boxed{6}, \dots \} \end{array} \right] \end{array} \right]$$

$$(20) \left[ \begin{array}{l} \textit{disc-obj-nm-np-frag-cl} \\ \text{C-SEM} \left[ \begin{array}{l} \text{RELS} \langle \textit{msg}, \left[ \begin{array}{l} \textit{soa} \\ \text{RELN} \boxed{7} \textit{soa-relation} \\ \text{ARGA} \boxed{4} \\ \text{ARGB} \boxed{1} \end{array} \right], \dots \rangle \end{array} \right] \\ \text{CTXT} \left[ \begin{array}{l} \text{FOC-ATT} \langle \boxed{6} \rangle \\ \text{SEM} \left[ \begin{array}{l} \textit{sem-obj} \\ \text{ID} \boxed{4} \\ \text{RELS} \langle \text{RELN} \boxed{F} \rangle \\ \text{FACTS} \left\{ \left[ \begin{array}{l} \textit{soa} \\ \text{RELN} \boxed{7} \\ \text{ARGA} \boxed{F} \\ \text{ARGB} \boxed{G} \end{array} \right], \dots \right\} \end{array} \right] \\ \text{DISC-OBJS} \{ \boxed{6}, \dots \} \end{array} \right] \\ \text{NON-HEAD-DTRS} \left[ \begin{array}{l} \textit{sign} \\ \text{SYNSEM} \textit{synsem} \\ \text{SEM} \left[ \begin{array}{l} \text{ID} \boxed{1} \\ \text{RELS} \langle \text{RELN} \boxed{G} \rangle \\ \text{FACTS} \{ \boxed{5}, \dots \} \end{array} \right] \end{array} \right] \end{array} \right]$$

The type *disc-obj-nm-np-frag-cl* how resolution upon the knowledge-base is modeled. We lack empirical evidence for deciding whether this kind of resolution is introduced in this specific type or in a more general type. At the moment all fragments encountered in which this kind of resolution is required where syntactically NPs and the anchor was previously introduced in the discourse. For illustrative purposes we will present the formalization of this type of resolution within a more specific type which is the result of crossing the types *np-frag-cl*, *non-mod-frag-cl* and *disc-obj-frag-cl*. This type accounts for the fragment in (1).

The semantic-object in focus of attention is an element of DISC-OBJS and has in its set of FACTS a pointer to a generic-*soa* in the knowledge-base in which it is

asserted that between the concept of which this semantic-object is an instance and the conceptual relation instantiated by the remnant holds a relation. This relation will be the value of the feature RELN in the soa with which the fragment is resolved. Both the anchor and the remnant are arguments of this soa-relation<sup>17</sup>.

## 6 Conclusion

In this paper we have discussed two previous approaches to the analysis of fragments: a grammar-based one and a coherence-based one. With the former we share the view that the use of fragments must be constrained from within the grammar. However, the discourse-structure assumed in this theory is very rigid and doesn't fully predict which previous utterances are accessible for ellipsis resolution. With the later approach we agree on the view that there are two kinds of ellipsis resolution: *via-identity* and *via-inference*. However, in this approach, as well as in the grammar-based one, the output of resolution is always a semantic-structural representation. This is in our view not always possible, since in fragments requiring some inference to be done, certain pieces of meaning have never been uttered and, thus, there is no linguistic semantic-structural representation of them at all. Moreover, when there is a long distance between source and fragment structural information may not be any more available for resolution. Unlike these approaches we are in favor of a treatment of remnants as non-head daughters, and against the existence of syntactic parallelism.

We model accessibility for ellipsis resolution *via-identity* by means of a discourse-record and the focus of attention. The discourse-record is a memory buffer containing different level representations of previous utterances. The structural representation is rapidly forgotten, while the semantic-conceptual representation remains longer in memory. Utterances whose semantic-structural representation is still in memory are accessible for ellipsis resolution. On the other hand, the discourse goals determine whether the topic addressed by a certain utterance is still open, in which case it may be in focus of attention and available for ellipsis resolution.

The contextual anchors of fragments which are resolved *via-inference* are semantic-objects either in the discourse-pool or in the physical environment, the dynamic sub-sets of the CP's Shared Beliefs. When these objects are in focus of attention, knowledge about them is activated, which allows to infer their relation to the remnant of the fragment.

## References

Alcántara, Manuel and Bertomeu, Núria. 2005. Ellipsis in Spontaneous Spoken

---

<sup>17</sup>For example, if upon the knowledge-base the relation between musicians and prizes is *obtain*, the fragment is resolved "obtain(Anastacia, prizes)", since the knowledge-base also contains the assertion that Anastacia is a musician.

- Language. In Petra Hendrix and Jennifer Spenader (eds.), *Workshop on Cross-modular Approaches to Ellipsis*, ESSLLI 2005, Edinburgh.
- Carberry, Sandra. 1985. A pragmatics-based approach to understanding intersentential ellipsis. In *Proceedings of the 23rd annual meeting on Association for Computational Linguistics*.
- Crocker, Matthew W. 1999. Mechanisms for sentence processing. In Garrod and Pickering (eds.), *Language Processing*, Psychology Press.
- Ginzburg, Jonathan. 1997. *A Semantics for Interaction in Dialogue*, Chapter 6: Querying and Assertion in Dialogue, II: defeasible presuppositions, fact ellipsis, and non-cooperativity. forthcoming from CSLI Publications and University of Chicago Press.
- Ginzburg, Jonathan and Sag, Ivan A. 2001. *Interrogative investigations, the form meaning and use of English interrogatives..* CSLI Publications.
- Ginzburg, Jonathan, Sag, Ivan A. and Purver, Matthew. 2003. *Perspectives on Dialogue in the New Millennium*, volume 114 of *Pragmatics Beyond, New Series*, Chapter Integrating Conversational Move Types in the Grammar of Conversation, pages 25–42. John Benjamins.
- Green, Georgia M. 1996. The structure of CONTEXT: The representation of pragmatic restrictions in HPSG. In James Yoon (ed.), *Proceedings of the 5th annual meeting of the Formal Linguistics Society of the Midwest*, Studies in the Linguistic Sciences.
- Gregory, Howard and Lappin, Shalom. 1997. A computational model of ellipsis resolution. In *Proceedings of the Conference on Formal Grammar*, ESSLLI 1997, Aix-en-Provence.
- Kintsch, W. and van Dijk, T.A. 1978. Toward a model of text comprehension and production. *Psychology Review* 85.
- LuperFoy, Susann. 1991. *Discourse pegs: A computational analysis of context-dependent referring expressions*. Ph. D.thesis, The University of Texas at Austin.
- Pollard, Carl and Sag, Ivan A. 1994. *Head-driven Phrase Structure Grammar*. University Chicago Press.
- Schlangen, David. 2003. *A Coherence-Based Approach to the Interpretation of Non-Sentential Utterances in Dialogue..* Ph. D.thesis, Institute for Communication and Collaborative Systems, School of Informatics, University of Edinburgh.
- Wierzbicka, Anna. 1988. *The semantics of grammar*, volume 18 of *Studies in Language Companion Series*. John Benjamins.