

Persian free relatives

Mehran A. Taghvaipour

University of Essex

Proceedings of the 12th International Conference on
Head-Driven Phrase Structure Grammar

Department of Informatics, University of Lisbon

Stefan Müller (Editor)

2005

Stanford, CA: CSLI Publications

pages 364–374

Taghvaipour, Mehran A. 2005. Persian free relatives. In Stefan Müller (ed.), *Proceedings of the 12th International Conference on Head-Driven Phrase Structure Grammar, Department of Informatics, University of Lisbon*, 364–374. Stanford, CA: CSLI Publications. DOI: 10.21248/hpsg.2005.21.



Abstract

Free relatives (FRs) in Persian are Unbounded Dependency Constructions, containing gaps or resumptive pronouns (RPs). In some positions only gaps are allowed, and in some other positions only RPs. The structure of Persian FRs is bipartite, containing two constituents: a phrasal part and a sentential. Persian FRs are sensitive to the matching effect and show distinct properties from noun phrases, ordinary relative clauses, and interrogative complements. This paper proposes a unified HPSG account which assumes that the phrasal part of a FR is the head and the filler at the same time. The propped approach is presented in two versions (with and without traces) and can take care of the dependency between the gap or the RP and the licencing constituent with a truly single mechanism.

1. Introduction

Example (1) shows a Persian FR in brackets.

- (1)
Yasmin [hærči Amy ____ xærیده.bud] ra¹ bærdašt.
Yasmin whatever Amy ____ had.bought RA took-3sg
'Yasmin took whatever Amy had bought.'

The structure of Persian FRs is bipartite, containing a phrasal part and a sentential part. The phrasal part always contains a word which has the prefix *hær-*, '-ever'. The sentential part is an incomplete finite sentence that contains either a gap or a RP. In subject and direct object positions only gaps are allowed; whereas, in object of preposition and genitive positions only RPs. Unlike ordinary relative clauses, FRs in Persian do not have any complementary position where both gaps and RPs are allowed. Persian data show that FRs in this language are sensitive to the 'matching effect'. Additionally, they allow 'pied piping', and the complementizer *ke*, which is obligatory in ordinary RCs, is optional in FRs.

2. The Analysis

I will use – among other things- three nonlocal features to capture the properties of FRs in Persian. One of these nonlocal features is the SLASH feature that will take care of the dependency between the gap or the RP and the FR phrase. The second is the GAPTYPE feature that handles the pattern of distribution of gaps and RPs. The third is the F-REL feature which is used to achieve two goals: (i) to distinguish words which can occur in FR constructions, and (ii) to determine the semantic content of the entire FR clause (Kim (2001)).

¹ This particle (whose colloquial form is *ro* or simply *-o*) is referred to as a specificity marker (Karimi, 1989). It comes after an NP when the NP is specific and is not in the position of subject or object of preposition.

A variety of evidence from coordination, parasitic gaps, crossover, and island constraints shows that Persian gaps and RPs are strikingly similar (See Taghvaipour (2005: 49)). To capture the similarities of RPs and gaps, I shall propose two possible approaches: one with traces and one without.

In the trace approach, gaps are treated as traces (as in Pollard and Sag's (1994), Levine and Hukari (2003), and Lee (2004)). In this approach, RPs are similar to traces except in two respects. Firstly, RPs will have phonological content whereas traces will not. Secondly, the value of their GAPTYPE features is different. GAPTYPE is a non-local feature whose value can be either *trace* or *rp*, for traces and RPs, respectively. The reason for distinguishing traces and RPs with a NONLOCAL feature is that this is not reflected within the value of SLASH and hence it is possible for a single unbounded dependency to be associated with a trace and an RP. This makes the inheritance of the nonlocal feature easy and possible in the middle of those UDCs which involve coordination of two NPs where one contains a RP and the other a gap. Other analyses (e.g., Vaillette (2001)) which utilise more than one nonlocal feature (SLASH and RESUMP) do not seem to be able to handle the inheritance of the features in such coordinate structures that contain gap in one conjunct and RP in the other. I propose the following lexical entry for trace.

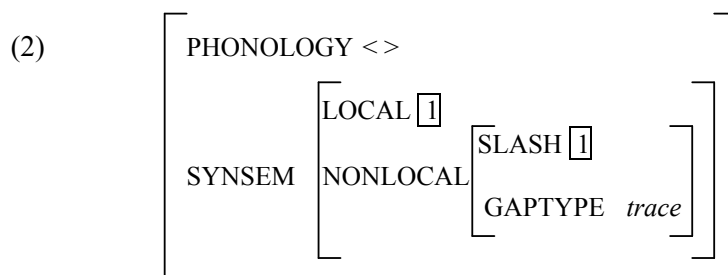

However, because RPs are not allowed in object positions in FRs, we require a more complex value for SLASH to encode the information we require to show what type of unbounded dependency (e.g., *wh*-interrogative, relative clause, free relative, etc.) the gap or the RP is used in. In this way, the encoded information is accessible not only at the bottom of the dependency but also at the top.

Similar to Przepiorkowski's (1999) assumption for the value of argument structure and valence features, I will assume that the value of SLASH is a set of *ud-object* elements, for which two features are appropriate: LOCAL and UD-TYPE. The value of LOCAL is a set of *local* structures, and the value of UD-TYPE is *ud-type*, which can be for instance *rc* (for relative clauses), *fr* (for free relatives), or *wh* (for *wh*-interrogatives). I assume that the value of SLASH is complex, as given in (3). The hierarchy in (4) shows three of the possible instances of *ud-type*.

(3)

$$\text{SLASH} \left\{ \begin{array}{l} \text{ud-object} \\ \text{LOCAL} \quad \text{local} \\ \text{UD-TYPE} \quad \text{ud-type} \end{array} \right\}$$

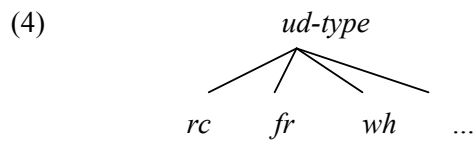

Thus, the nonempty SLASH feature in the sentential part of the FR encodes the information that there is a dependency between the trace/RP and the FR phrase, which can be of any arbitrary distance from the trace/RP.

I will propose the lexical entry in (5) for RPs and the one in (6) for traces. These lexical entries are the same except in two respects. Firstly, the value of the PHON feature in traces is an empty set; whereas in RPs, it is not empty. This means that RPs as overt elements have phonology but traces do not. The second difference between these two lexical entries is that the value of their GAPTYPE feature is different.

As I noted earlier, GAPTYPE is a feature that I have introduced to capture the distributional properties of RPs and traces. GAPTYPE is a non-local feature whose value can be either *trace* or *rp*. This treatment differentiates the *synsem* values of traces and RPs and allows me to subject them to different constraints, while the distinction is not reflected within the value of SLASH; and hence, it is possible for a single unbounded dependency to be associated with a trace and an RP.

(5) A resumptive pronoun

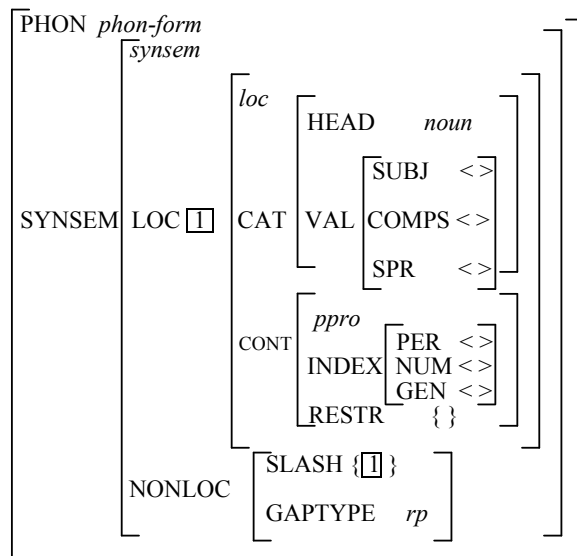

(6) A trace in a nominal position

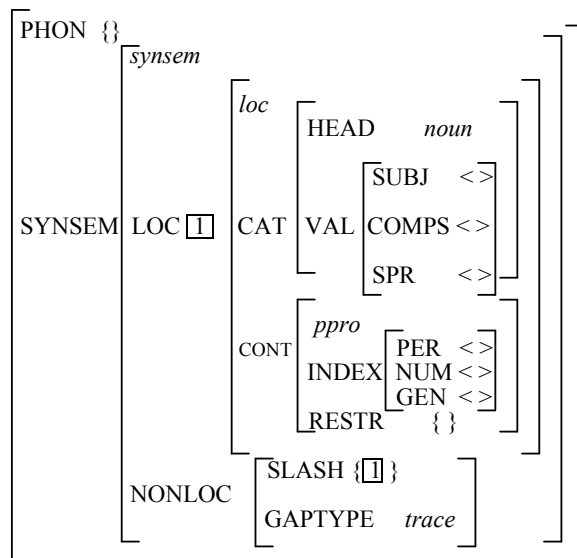

I noted earlier that RPs are not allowed in subject or direct object positions, while traces are not allowed in the positions of genitive or object of preposition. The constraint in (7) is to take care of RPs in subject position. The effect of this constraint is that if an element is a resumptive pronoun, then it cannot come in subject position.

(7) RESUMPTIVE SUBJECT CONSTRAINT

$$[\text{SUBJ } \langle \boxed{1} \rangle] \rightarrow \sim (\boxed{1} = [\text{SYNSEM}| \text{NONLOC}| \text{GAPTYPE } rp])$$

To prevent traces from appearing in the positions of object of preposition and possessor, I propose the RESUMPTIVE NON-VERB CONSTRAINT in (8). According to this constraint, if there is a nominal trace in the complement of a verb, then that head has to be a verb. Thus, in the case of object of preposition and genitive cases (possessors), we will not have a trace because the head is not a verb.

(8) RESUMPTIVE NON-VERB CONSTRAINT

$$\left[\begin{array}{l} \text{HEAD } \boxed{1} \\ \text{COMPS } \langle \dots, \left[\begin{array}{l} \text{HEAD } \textit{noun} \\ \text{GAPTYPE } \textit{trace} \end{array} \right], \dots \rangle \end{array} \right] \rightarrow \boxed{1} = \textit{verb}$$

Finally, to prevent resumptive pronouns from appearing in direct object positions in Persian FRs, I propose the constraint in (9).

(9) RESUMPTIVE OBJECT CONSTRAINT

$$\left[\begin{array}{l} \text{HEAD } \textit{verb} \\ \text{COMPS } \langle \dots, \left[\begin{array}{l} \text{GAPTYPE } \textit{rp} \\ \text{SLASH } \{ [\text{UD-TYPE } \boxed{1}] \} \end{array} \right], \dots \rangle \end{array} \right] \rightarrow \sim \boxed{1} = \textit{fr}$$

The effect of this constraint is that if a complement of a verb is a RP, then the UD-TYPE value of that pronoun cannot be *fr*. In other words, a pronoun which is resumptive by having a *rp* value for its GAPTYPE feature and is used as a complement of a verb cannot be used in unbounded dependencies of the type free relative (*fr*).

Where there are some analyses (e.g., Pollard and Sag (1994: ch.1-8), Hukari and Levine (2003), and Sun-hee (2004)) that favour traces, there are also some analyses (e.g., Pollard and Sag (1994: ch.9), Sag and Fodor (1994), Sag (1997), Ginzburg and Sag (2000), and Bouma et al (2001)) that favour a traceless approach. In such approaches, there is a mechanism that makes a non-empty SLASH value appear at the bottom of dependency.

In earlier HPSG works (e.g., Pollard and Sag (1994), Sag and Fodor (1994) and Sag (1997)), this mechanism is in the form of a lexical rule (e.g. CELR) whose outputs stipulate a non-empty SLASH value. But as noted by Bouma et al. (2001), lexical rules are not desirable for two reasons: (i) they are meant to account for processes that are morphological in nature, and (ii) their formal status is a matter of debate.

In more recent analyses, (e.g., Ginzburg and Sag (2000) and Bouma et al (2001)), traceless accounts for filler-gap dependencies are provided without lexical rules. Bouma et al, following Sag (1997), assume the hierarchy in (10) for *synsem*.

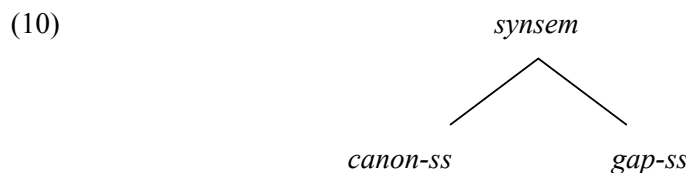

According to this hierarchy, gaps have *synsem* of type *gap-ss*, which obey the constraint in (11). According to this constraint, the LOCAL value of a *gap-ss* element corresponds to its SLASH value.

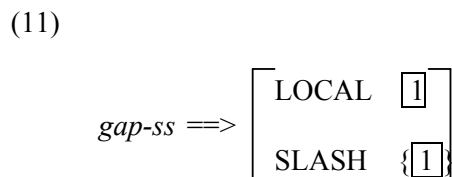

To provide a traceless approach to the bottom of dependency, I shall assume the hierarchy in (12) for *synsem*. This hierarchy treats *synsems* of RPs to be of type *rp-ss*, a mixed category: a subtype of *gap-ss* and *canon-ss* at the same time. As a result of being a subtype of *gap-ss*, the LOCAL value of a *rp-ss* element corresponds to its SLASH value (by virtue of Sag's (1997) constraint on *gap-ss*). Moreover, as *rp-ss* is a subtype of *canon-ss*; by virtue of the Principle of Canonality, RPs are overt linguistic expressions.

(12)

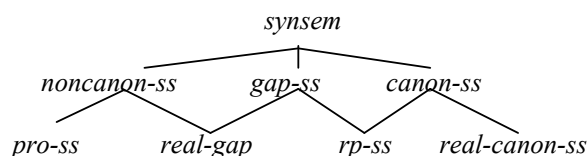

Ginzburg and Sag's (2000) Argument Realization Principle with a little modification (replacing *gap-ss* with *real-gap-ss*) works here as well. The principle can take care of RPs that are present on both ARG-ST list and COMP list, and gaps that may be present in the ARG-ST list but absent from the COMP list.

All we need now is to impose various constraints on RPs (whose *synsem* is of the type *rp-ss*) to look after their pattern of distribution of gaps and RPs. The constraints in (13) to (15) do the jobs of the constraints in (7) to (9) above.

(13) RESUMPTIVE SUBJECT CONSTRAINT (TRACELESS)

$$[\text{SUBJ } \langle \boxed{1} \rangle] \rightarrow \sim \boxed{1} = rp-ss$$

(14) RESUMPTIVE NON-VERB CONSTRAINT (TRACELESS)

$$\left[\begin{array}{l} \text{HEAD } \boxed{1} \\ \text{ARG-ST } \langle [], \dots, \left[\begin{array}{l} \text{real-gap-ss} \\ \text{HEAD } \textit{noun} \end{array} \right], \dots \rangle \end{array} \right] \rightarrow \boxed{1} = \textit{verb}$$

(15) RESUMPTIVE OBJECT CONSTRAINT (TRACELESS)

$$\left[\begin{array}{l} \text{HEAD } \textit{verb} \\ \text{COMPS } \langle \dots, \left[\begin{array}{l} \text{rp-ss} \\ \text{SLASH } \{ [\text{UD-TYPE } \boxed{1}] \} \end{array} \right], \dots \rangle \end{array} \right] \rightarrow \sim \boxed{1} = \textit{fr}$$

In the middle of dependency, I do not propose anything new. I will follow Sag (1997) but use Generalised Head Feature Principle of Ginzburg and Sag's (2000).

At the top of the dependency, the SLASH feature needs to be bound off at an appropriate point. Similar to Wright and Kathol's (2003) analysis, I assume that this appropriate point is the relative phrase which acts as the filler. However, if the relative phrase is the filler, then naturally, we expect to have the sentential part as the head, as shown by a thicker line in (16).

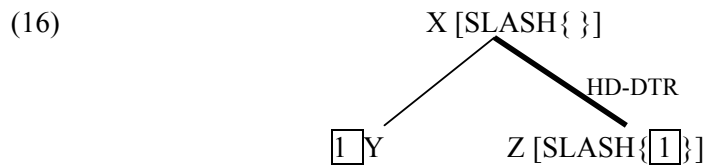

Persian data do not support this idea and suggest that it is the relative phrase that acts as the head in determining the external distribution of the phrase. For example, categorical matching comes from the relative phrase. Thus, I assume that the relative phrase in a Persian FR is the head and the filler at the same time. I will propose the structure in (17) for Persian FRs in which the filler is the head daughter.

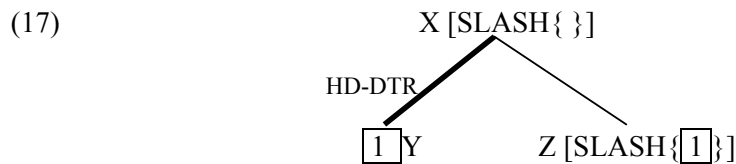

In both (16) and (17) above, we require the mother, (i.e., X) to be slash empty. Standard HPSG constraints that operate on headed phrases will suffice for (16) and will make sure that the filler combines with the head so that the mother phrase is an empty slash phrase. However, for (17) we will need more constraints which can operate on non-heads. I will therefore propose the constraint in (18) on Persian FRs.

(18)

$$\text{free-relative} \rightarrow \left[\begin{array}{l} \text{SLASH } \{ \} \\ \text{DTRS} < [1] \left[\begin{array}{l} \text{F-REL } \{ [] \} \\ \text{LOC} [2] \end{array} \right] \left[\begin{array}{l} \textit{phrase} \\ \text{HEAD } \textit{verbal} \\ \text{SLASH } \{ [\text{LOC} [2]] \} \end{array} \right] > \\ \text{HD - DTR} [1] \end{array} \right]$$

There are two points noteworthy in this constraint. Firstly, the filler is the head daughter in this constraint for the reasons discussed in the previous paragraph. Secondly, the value of HEAD is *verbal*, not *v*. Following Sag (1997), I assume that *verbal* is a supertype of both verb (*v*) and complementizers (*c*). This assumption will allow us to handle the optionality of complementizer *ke* in Persian FRs.

There is also another nonlocal feature which originates at the relative phrase: the F-REL feature. We noted earlier that all Persian FRs start with the prefix *hær-*, ‘-ever’. This prefix is followed by either a *wh*-word, like *čī* (what), *ki* (who), and *koja* (where), or a noun like *kæs*, ‘person’, *ja*, ‘place’, and *væqt*, ‘time’. Of course, not all Persian *wh*-words are eligible to occur as fillers in FR constructions, neither are all *hær* elements allowed to come in Persian FRs.

To differentiate phrases that are eligible to occur as fillers in the FRs, I will use, following Kim’s (2001), the nonlocal feature F-REL which takes a set of referential indices as its value (Jacobson (1976), Kim and Park (1996) as cited in Kim (2001: 42)). FR words will have a nonempty specification for this feature. Other instances of *hær*- combinations or *wh*-words in any context other than the FR will have empty F-REL features.

Following Wright and Kathol (2003), I also assume that relative phrases need to be distinguished semantically as well. Therefore, I will assume that it is the value of the filler’s F-REL feature that determines the content of the entire FR clause. This feature is assumed to be projected from the relative word in the same manner that the SLASH feature is projected from the incomplete sentential part of the FR.

Following Kim (2001: 43), I will assume that the F-REL generated from a lexical entry is subject to the lexical amalgamation constraint as given in (19).

(19) Lexical Amalgamation of F-REL

$$\text{word} \implies \left[\begin{array}{l} \text{ARG-ST} < [\text{F-REL } \boxed{1}], \dots, [\text{F-REL } \boxed{n}] > \\ \text{F-REL } \boxed{1} + , \dots, + \boxed{n} \end{array} \right]$$

This constraint ensures that if any element of a lexical head has a F-REL value, the lexical head itself also has the same F-REL value. This lexical amalgamation constraint combined with the Generalized Head Feature Principle of Ginzburg and Sag (2000), will take care of the inheritance of the F-REL value. Thus, the Lexical Amalgamation of F-REL prompts the lexical head to bear the feature F-REL, and the GHFP ensures that this value is identical between the head daughter and the head.

References

- Bouma, G., R. Malouf, and I. Sag, 2001. Satisfying Constraints on Extraction and Adjunction. *Natural Language and Linguistic Theory* 19:1-65.
- Ginzburg J. and I. Sag, 2000. *Interrogative Investigations: The Form, Meaning, and Use of English Interrogatives*. CSLI Publications, Stanford, California.
- Kubota, Y. 2003. Yet Another HPSG-Analysis for Free Relative Clauses in German. In *The Proceedings of the 9th International Conference on HPSG*. Stanford University. USA.
- Kim. J.B. 2001. Constructional Constraints in English Free Relative constructions. *Korean Society for Language and Information* 5(1): 35-53.
- Lee, S-H. (2004) *A Lexical Analysis of Select Korean Unbounded Dependency Constructions*. Doctoral dissertation in Ohio State University, USA.
- Levine, R. D. and T. Hukari. 2003. *The Unity of Unbounded Dependency Constructions*. University of Chicago Press. USA.
- Pollard C., and I. Sag, 1994. *Head-Driven Phrase Structure Grammar*. The University of Chicago Press, USA.
- Przepiokowski, A. 1998. Case Assignment and the Complement-Adjunct Dichotomy: A Non-Configurational Constraint-Based Approach, Doctoral dissertation, University of Tübingen, Germany.
- Sag, Ivan. 1997. English Relative Clause Constructions. *Journal of Linguistics* 33: 431-484.
- Taghvaipour, M. 2005. *Persian Relative Clauses in Head-driven Structure Grammar*. PhD Dissertation. University of Essex. UK.
- Vaillette, N., 2001. Hebrew Relative Clauses in HPSG. *Proceedings of the 7th International Conference on Head-Driven Phrase Structure Grammar*, CSLI Publications.
- Wright, A. and A. Kathol. 2003. When a Head is not a Head: A Constructional Approach to Exocentricity in English. In Jong-Bok Kim and Steve Wechsler (eds.) *Proceedings of the Ninth International Conference on Head-Driven Phrase Structure Grammar*. Pages: 370-387.