

Auxiliary-stranding relative clauses

Doug Arnold 

University of Essex

Robert D. Borsley 

University of Essex

Proceedings of the 17th International Conference on
Head-Driven Phrase Structure Grammar

Université Paris Diderot, Paris 7, France

Stefan Müller (Editor)

2010

Stanford, CA: CSLI Publications

pages 47–67

Arnold, Doug & Robert D. Borsley. 2010. Auxiliary-stranding relative clauses. In Stefan Müller (ed.), *Proceedings of the 17th International Conference on Head-Driven Phrase Structure Grammar, Université Paris Diderot, Paris 7, France*, 47–67. Stanford, CA: CSLI Publications. DOI: 10.21248/hpsg.2010.3. 

Abstract

A little discussed feature of English are non-restrictive relative clauses in which the antecedent is normally not an NP and the gap follows an auxiliary, as in *Kim will sing, which Lee won't*. These relative clauses resemble clauses with auxiliary complement ellipsis or fronting. There are a variety of analyses that might be proposed, but there are reasons for thinking that the best analysis is one where *which* is a nominal filler associated with a gap which is generally non-nominal: a filler-gap mismatch analysis in other words.

1. Introduction

In this paper we will investigate a type of non-restrictive (appositive, supplementary) relative clause (NRRC), which has been mentioned in various places but as far as we know never discussed in any detail. The following, where an underscore marks the gap, are typical examples:

- (1) a. Kim will sing, which Lee won't ____.
- b. Kim has sung, which Lee hasn't ____.
- c. Kim is singing, which Lee isn't ____.
- d. Kim is clever, which Lee isn't ____.
- e. Kim is in Spain, which Lee isn't ____.

Here we have NRRCs in which the antecedent is not an NP and the gap follows an auxiliary. We will call such examples auxiliary-stranding relative clauses (ASRCs). ASRCs were highlighted in Ross (1969) and are briefly discussed in Huddleston and Pullum (2002), who note on p. 1523 that 'there is ... a type of supplementary relative construction which strands auxiliary verbs'.¹ However, as far as we are aware, they have not hitherto received an explicit analysis in any framework. We will discuss ASRCs in some detail and consider how they might be analyzed within Head-driven Phrase Structure Grammar (HPSG). We will argue that they involve a filler-gap mismatch and that they are the product of an optional property of auxiliary verbs with a missing complement. In other words, they are a reflection of

↑ An earlier version of the paper was presented at the meeting of the Linguistics Association of Great Britain at the University of Edinburgh in September 2009. We are grateful to the audience there and at HPSG 2010 for their comments. We have benefited at various times from the comments of Emily Bender, Rui Chavez, Berthold Crysmann, Mary Dalrymple, Jean-Pierre Koenig, Bob Levine, Ivan Sag, Jesse Tseng and two anonymous reviewers for HPSG 2010. We alone are responsible for what appears here.

¹ ASRCs were also the focus of Borsley (1980).

another idiosyncrasy of a class of words which is well known for its idiosyncrasies.

The paper is organized as follows. Section 2 spells out the main properties of ASRCs and compares them with certain other types of clause. Sections 3, 4 and 5 look at three possible analyses, all of which have important weaknesses. Section 6 presents the filler-gap mismatch analysis and shows how it captures the properties of the construction. Section 7 considers two further possible analyses and looks at some further relevant data. Finally, section 8 concludes the paper.

2. Data

It is a rather well known property of NRRCs that they allow an antecedent which is not an NP. In most cases, this is, we think, unsurprising. However, as we will see, ASRCs are rather surprising.

It is not at all surprising firstly that we have a non-nominal antecedent in the following:

- (2) I saw Kim in London, where I also saw Sandy ____.
- (3) I saw Kim on Tuesday, when I also saw Sandy ____.

Here we have NRRCs containing the adverbial *wh*-words *when* or *where*. It is not surprising, then, the antecedents are non-nominal, a locative PP in (2) and a temporal PP in (3).

Rather different but also unsurprising in our view are examples like the following:

- (4) Kim was late, which ____ was unfortunate.
- (5) Kim is riding a camel, which ____ is really difficult.

These examples contain the nominal *wh*-word *which* and it is associated with a gap in a nominal position, subject position in both cases. In (4), the antecedent is a clause and in (5) it is a VP. It seems to us that *which* in these examples refers to an abstract entity introduced into the discourse which can be referred to in various ways, for example by an ordinary pronoun. Thus, instead of (4), we could have (6) and (7), and instead of (5) we could have (8) and (9):

- (6) Kim was late. It was unfortunate.
- (7) Kim was late. This fact was unfortunate.
- (8) Kim is riding a camel. It's really difficult.
- (9) Kim is riding a camel. This activity is really difficult.

Hence, these examples conform to Huddleston and Pullum's (2002:1063) observation that 'supplementary relatives can be replaced by other kinds of supplements containing non-relative anaphoric expressions, notably personal pronouns or demonstratives'.

Further evidence that these examples are unsurprising comes from the fact that *which* can also be replaced by interrogative and pseudo-cleft *what*. Thus, corresponding to (4) we have (10) and (11), and corresponding to (5) we have (12) and (13).

(10) A: What ___ was unfortunate?

B: That Kim was late.

(11) What ___ was unfortunate was that Kim was late.

(12) A: What ___ is really difficult?

B: Riding a camel.

(13) What ___ is really difficult is riding a camel.

It seems to us, then, that examples like (4) and (5) pose no special problems.

We return now to ASRCs. It seems that the gap may follow any auxiliary. The following illustrate:

(14) a. Kim will sing, which Lee won't.

b. Kim has sung, which Lee hasn't.

c. Kim is singing, which Lee isn't.

d. Kim is clever, which Lee isn't.

e. Kim is in Spain, which Lee isn't.

f. Kim wants to go home, which Lee doesn't want to.

(14a) contains the modal *will*, and (14b) contains perfective *have*. (14c-e) contain *be* with a verbal, an adjectival, and a prepositional complement. Finally, (14f) contains *to*, which following Pullum (1982) and Levine (2010), we assume is a defective auxiliary verb.² The gap may not follow a lexical verb. Hence the following are bad:

(15) a. *Kim tried to impress Lee, which Sandy didn't try ____.

b. *Kim persuaded Lee to go, which he didn't persuade Sandy ____.

² We also find examples where *be* expresses identity, e.g. the following:

(i) Chomsky is the author of *Aspects*, which Halle isn't.

ASRCs are very different from the nominal gap examples in (4) and (5). *Which* in an ASRC cannot generally be replaced by an in-situ referring expression. The following seem quite bad:

- (16) a. *Kim will sing, but Lee won't it/that.
- b. *Kim has sung, but Lee hasn't it/that.
- c. *Kim is singing, but Lee isn't it/that.
- d. *Kim is clever, but Lee isn't it/that.
- e. *Kim is in Spain, but Lee isn't it/that.
- f. *Kim wants to go home, but Lee doesn't want to it/that.

Thus, ASRCs are generally an exception to Huddleston and Pullum's observation cited above.³

Interrogative and pseudo-cleft *what* are also generally impossible, as the following show:

- (17) A: *What will Kim ___?
- B: Sing.
- (18) A: *What has Kim ___?
- B: Sung.
- (19) A: *What is Kim ___?
- B: Singing.
- (20) A: *What is Kim ___?
- B: In Spain.
- (21) A: *What does Kim want to ___?
- B: Go home.

- (22) *What Kim will ___ is sing.

³ There seem to be some acceptable examples with an in-situ *that*. Ross (1969: 84) gives the following:

- (i) They said that Tom is working hard, and he is that.

Unlike the superficially rather similar (16c), this seems to be quite good. We have also found some naturally occurring examples with an in-situ *that* following a modal, e.g. (ii) from the British National Corpus (K/KP/KPM around line 0023; it is from a conversation -- probably Central N England).

- (ii) A: They all, they all huddled together and then when they started to get warm it'd pong a bit, wouldn't it?
- B: It would that, yes.

This seems much better than (16a). It seems, then, that at least some auxiliaries allow an in-situ *that* under some circumstances. However, what these circumstances are is quite difficult to pin down (it seems to require a particular intonation pattern, seems not to be compatible with negation, or with an expression of disagreement – B's utterance in ii) could not be replaced with **It wouldn't that, no.*). This seems rather different from the general availability of relative *which* with a gap following an auxiliary.

- (23) *What Kim has ___ is sung.
- (24) *What Kim is ___ is singing.
- (25) *What Kim is ___ is in Spain.
- (26) *What Kim wants to ___ is go home.

Rather surprisingly, interrogative and pseudo-cleft *what* seem okay with an adjectival interpretation:

- (27) A: What is Kim ___?
B: Clever.
- (28) What Kim is ___ is clever.

We are not sure why this should be. However, apart from this, interrogatives and pseudo-clefts distinguish ASRCs and examples like (4) and (5) fairly clearly.

The examples in (14) look rather like sentences involving VP-ellipsis, or auxiliary complement ellipsis in Warner's (2000) more appropriate terminology, as in (29):

- (29) a. Kim will sing, but Lee won't.
- b. Kim has sung, but Lee hasn't.
- c. Kim is singing, but Lee isn't.
- d. Kim is clever, but Lee isn't.
- e. Kim is in Spain, but Lee isn't.
- f. Kim wants to go home, but Lee doesn't want to.

They are also rather like sentences involving VP-fronting, which should probably be called auxiliary complement fronting.

- (30) a. They say Kim will sing, and sing he will.
- b. They say Kim has sung, and sung he has.
- c. They say Kim is singing, and singing he is.
- d. They say Kim is clever, and clever he is.
- e. They say Kim is in Spain, and in Spain he is.
- f. They say Kim wants to go home, and go home he wants to.

An important question about ASRCs is exactly how similar they are to auxiliary complement ellipsis sentences and auxiliary complement fronting sentences.

Like auxiliary complement ellipsis sentences, ASRCs allow the gap and the antecedent to differ in various ways. While the gap must be an auxiliary complement, this is not the case with the antecedent, as the following show:

- (31) Kim rode a camel, but I never will.
- (32) Kim rode a camel, which I never will.

Moreover, where the antecedent is an auxiliary complement it may still differ from the gap in certain ways. In the following, the missing complement of *would* is a base VP whereas the antecedent is a past participle VP.

- (33) Kim has ridden a camel, but I never would.
- (34) Kim has ridden a camel, which I never would.

Similarly, in the following, the missing complement of *have* is a past participle VP whereas the antecedent is a present participle VP.

- (35) Kim is riding a camel, but I never have.
- (36) Kim is riding a camel, which I never have.

A further point that is worth noting here is that the gap and the antecedent may be an NP in both auxiliary complement ellipsis sentences and ASRCs. This is because *be* can take a nominal complement. Thus, we have examples like the following:

- (37) Kim is a linguist, but Lee isn't.
- (38) Kim is a linguist, which Lee isn't.

The fact that we have *which* with a human antecedent in (38) shows that the relative clause is not an ordinary NRRC but an ASRC.

There are, however, some differences between ASRCs and auxiliary complement ellipsis sentences. Auxiliary complement ellipsis is an optional process. Hence the gap in an auxiliary complement ellipsis sentence can be 'filled in'. This is not possible with the gap in an ASRC:

- (39) Kim will sing, but Lee won't sing.
- (40) *Kim will sing, which Lee won't sing.

Moreover it seems that ASRCs but not auxiliary complement ellipsis sentences are subject to island constraints. (41) and (42) show that ASRCs are subject to the Complex Noun Phrase Constraint and the Coordinate Structure Constraint.

- (41) a. Kim is singing, which I don't believe that Lee is.
b. *Kim is singing, which I don't believe the claim that Lee is.
- (42) Kim has never ridden a camel, which
 - a. Sam has ___ and Bill probably will ___.
 - b. *Sam has ___ and Bill probably will ride one/a camel.

This is unlike VP ellipsis

- (43) a. Kim is singing, but I don't believe that Lee is.
 b. Kim is singing, but I don't believe the claim that Lee is.
- (44) Kim has never ridden a camel, which
 a. Sam has ___ and Bill probably will ____.
 b. Sam has ___ and Bill probably will ride one/a camel.

This suggests that ASRCs like ordinary NRRCs are an unbounded dependency construction.⁴

In the following sections, we will consider how ASRCs should be analyzed. We will look at four different HPSG analyses, the second and third being somewhat similar. Three of these analyses seem unsatisfactory, but the fourth appears to provide a satisfactory account of the data.

3. A simple filler-gap analysis

We will first consider an analysis in which *which* is a pronominal counterpart of the categories that appear as complements of an auxiliary, most often a VP. This gives structures like (45), where *i* and *j* are eventive/stative indices and following Arnold (2004, 2007), $j \approx i$ means that *j* is anaphorically dependent on *i*.⁵

⁴ There are certain restrictive relative clauses which look rather like ASRCs but are in fact rather different. Here is an example from Bob Levine:

- (i) There are many books that I will read, but there is one which I definitely won't ____.

Here, we have a restrictive relative introduced by *which* with an auxiliary complement gap. However, *which* is associated not with the missing complement as a whole but with just part of its meaning. The second clause in (i) means the same as (ii).

- (ii) There is one which I definitely won't read ____.

Thus, this seems a rather different phenomenon.

⁵ We assume that various types of phrase, including VPs, PPs, and APs, can make available discourse referents corresponding to abstract entities of various sorts (events, states and properties etc). These can be accessed by anaphoric pronouns like *it*, *this*, and *that*, as in examples (6)-(9), and by relative *which* as in *Kim will sing, which Lee won't*. We assume they can be accessed in a similar way by VP Ellipsis. From a semantic point of view, there is no important difference between cases of VP Ellipsis, ASRCs, and cases of normal 'event' anaphora: all simply involve anaphoric dependence between an index associated with the pronoun, relative pronoun or ellipsis, and the index introduced by the antecedent. The only important difference is that the constructions are subject to different syntactic constraints. In particular, ASRCs are typically required to be adjacent to their antecedents, which is not required for normal anaphora and VP Ellipsis.

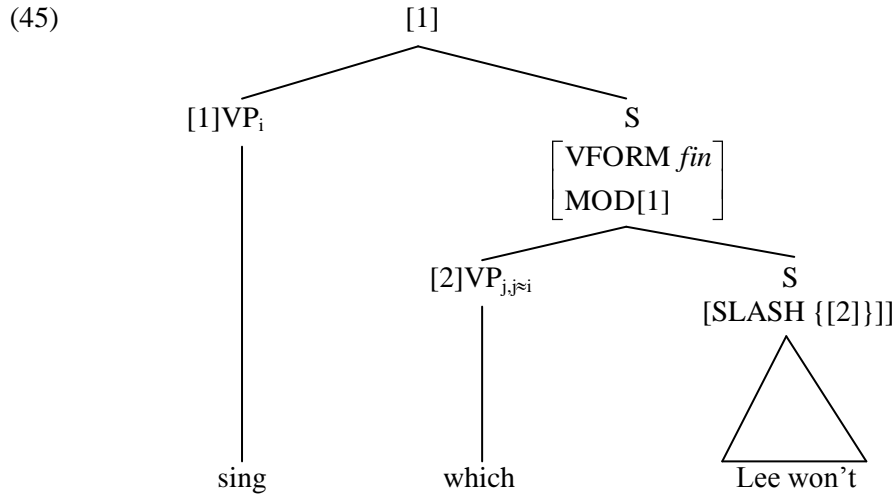

Here and subsequently we use XP to stand both for *synsem* objects and for *local* feature structures. The higher VP is a *synsem* object, while the lower VP is *local* feature structure. On this analysis ASRCs are just like ordinary appositive relatives except for the category of the gap and the antecedent. They are also essentially a special case of auxiliary complement fronting sentences. We will show that the analysis faces a number of problems.

One problem arises from the fact that ordinary VP complements of an auxiliary do not appear as fillers in a relative clause. Thus, only the (a) examples are acceptable in the following:

- (46) a. This is the book, which Kim will read ____.
- b. *This is the book, [read which] Kim will ____.
- (47) a. This is the book, which Kim has read ____.
- b. *This is the book, [read which] Kim has ____.
- (48) a. This is the book, which Kim is reading ____.
- b. *This is the book, [reading which] Kim is ____.

One might suppose that this is because VPs never appear as fillers in NRRCs. However, as discussed in Ishihara (1984), there are some cases where an infinitival VP or an *ing* VP appears as the filler in a relative clause, but these are not auxiliary complements.

- (49) a. The elegant parties, [to be invited to one of which] ____ was a privilege, had usually been held at Delmonico's.

- b. John went to buy wax for the car, [washing which] ____ Mary discovered some scratches in the paint.

The fact that an ordinary VP complement of an auxiliary cannot be a filler in a relative clause makes the idea that *which* is just a pronominal counterpart of the categories that appear as complements of an auxiliary rather implausible.

A second problem arises where the auxiliary is *ought*. Consider first the following grammatical example:

- (50) Kim ought to go home, which Lee ought not to ____.

Here, *to* is stranded, which we know is possible from (14f). Notice now that it is not possible to pied pipe *to*, giving (51):

- (51) *Kim ought to go home, to which Lee ought not ____.

On the analysis we are considering, *which* is a VP filler in (50). It is not clear, then, why it should not be possible to have a larger VP containing *to* as a filler.

A further problem involves *not*. As discussed by Kim and Sag (2002: Section 3), this can modify a non-finite VP, and, as the following shows, this includes a fronted non-finite VP:

- (52) They say Kim may be not coming, and not coming he may be ____.

If *which* can be a VP, one might expect examples in which it is modified by *not*, but they are not possible.

- (53) *Kim may be not coming, not which Lee may be ____.

Thus, the idea that *which* can be a VP seems quite dubious.

A final problem is that some of the categories that appear as complements of an auxiliary also appear as complements of lexical verbs. Hence there is no obvious way within this approach to rule out examples like those in (15).

It seems, then, that there are a number of reasons for rejecting the idea that *which* in ASRCs is just a pronominal counterpart of the categories that appear as complements of an auxiliary.

4. Non-filler analysis 1: A special construction

Since the obvious filler analysis of *which* seems untenable, one might suppose that it is not in fact a filler. One possibility would be to propose that

it is the ordinary nominal *which* but that it is not a filler because it does not match the SLASH value of its clausal sister.

On this approach, we would give structures like (54).

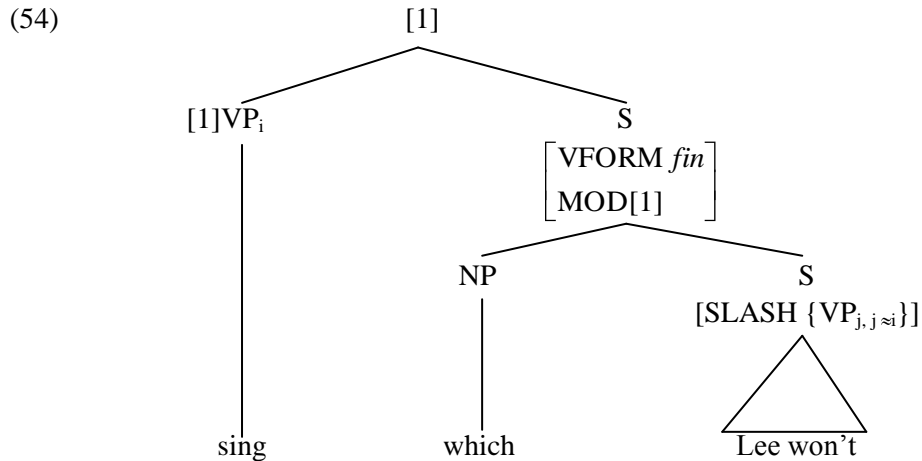

To license such structures one would require a special construction. One might propose a type *aux-stranding-rel-cl* subject to something like the following constraint (where ‘which’ of course is an abbreviation):

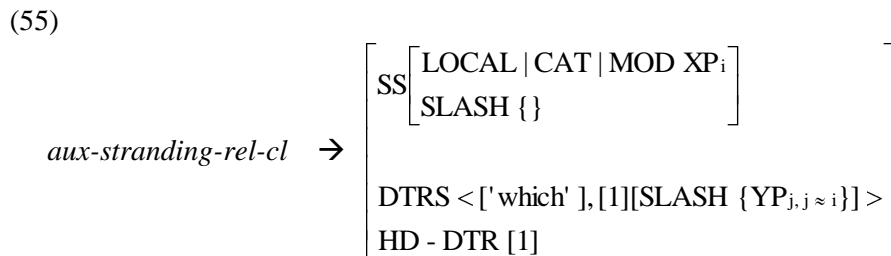

Here, the value of SLASH on the head daughter is anaphorically dependent on the value of MOD. This ensures that it is anaphorically dependent on the antecedent of the relative clause. Other things being equal, it is preferable to avoid special constructions like this, but one might think that it is justified in this case.

There are, however, two objections to this analysis. Firstly, it is incompatible with the otherwise sound generalization that NRRCs, unlike restrictive relatives, are always head-filler structures. Secondly, it makes it look as if what is special about ASRCs is at the top of the dependency, but it seems clear that there is something special at the bottom of the dependency, where the gap must follow an auxiliary. There is no obvious way for the analysis to restrict the gap to auxiliary complement position. Thus, it is not

obvious how to rule out the examples in (15). We conclude, then, that this is not a satisfactory approach.

5. Non-filler analysis 2: A head-complement analysis

Another possibility would be to propose that *which* in ASRCs is a head. More precisely, one might propose that it is a complementizer, which takes as its complement an S with a SLASH value including an eventive/stative index and heads a phrase which modifies a constituent with an eventive/stative index where the first index depends anaphorically on the second.

This approach does not require a special construction. It just requires *which* in ASRCs to have the following syntactic properties:

$$(56) \left[\begin{array}{l} \text{SS} | \text{LOCAL} | \text{CAT} \left[\begin{array}{l} \text{HEAD} \left[\begin{array}{l} c \\ \text{MOD XP}[i] \end{array} \right] \\ \text{COMPS} \langle \text{S}[\text{VFORM } fin, \text{SLASH} \{ \text{YP}[j], j \approx i \}] \rangle \end{array} \right] \end{array} \right] \right]$$

Here the value of SLASH on the complement is anaphorically dependent on the value of MOD. This ensures again that it is anaphorically dependent on the antecedent of the relative clause. Given (56), we will have structures like (57).

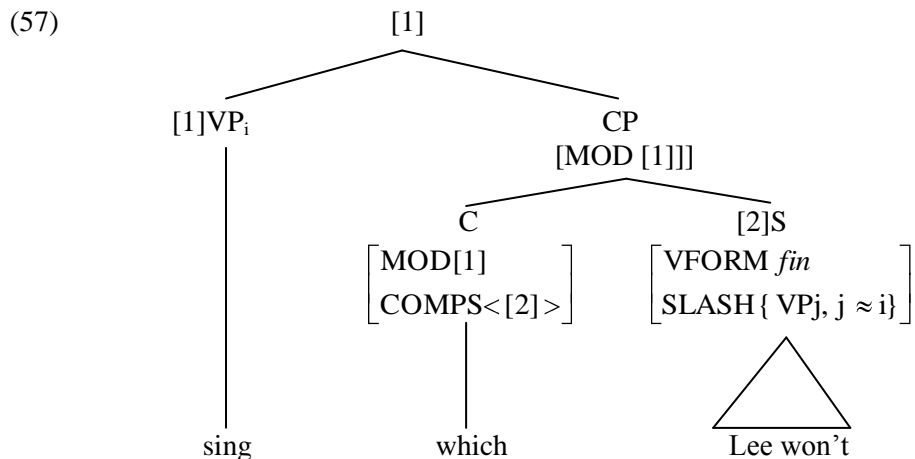

It is quite common for a *wh*-word to turn into a complementizer. It is notable, however, that this approach makes *which* in ASRCs very different from *which* in ordinary NRRCs, which does not take a complement or modify any constituent and has a non-null REL value. This seems rather undesirable.

The two objections that we raised against the special construction analysis are also applicable here. This analysis is incompatible with the generalization that NRRCs are head-filler structures. It also misses the fact that ASRCs involve something special at the bottom of the dependency, and there is also no obvious way for the analysis to restrict the gap to auxiliary complement position.

It seems, then, that this approach too is unsatisfactory.

6. A filler-gap mismatch analysis

We turn now to an analysis which we think provides a satisfactory account of the data. This is an analysis, in which *which* in ASRCs is a filler but a nominal filler which does not match the associated gap. In other words it is a filler-gap mismatch analysis. As discussed by Webelhuth (2008), there seem to be a number of examples of filler-gap mismatches in English. For example, the ungrammaticality of (59) suggests that (58) involves a clausal filler associated with a nominal gap.

(58) That he might be wrong, he didn't think of ____.

(59) *He didn't think of that he might be wrong.

It is quite possible that not all filler-gap mismatches have the same character, but there is a fairly straightforward filler-gap mismatch analysis which can be proposed for ASRCs.

Consider first auxiliary complement ellipsis. A fairly standard HPSG approach to ellipsis treats it as involving a head with an ARG-ST list element which does not appear in its COMPS list. If we adopt this approach, we can propose that auxiliaries in auxiliary complement ellipsis sentences have the following syntactic properties, where the precise nature of XP varies from auxiliary to auxiliary:

(60)

$$\left[\begin{array}{l} \text{SS | LOCAL | CAT} \\ \text{ARG - ST } \langle [1], \text{XP} \rangle \end{array} \left[\begin{array}{l} \text{HEAD} \left[\begin{array}{l} v \\ \text{AUX +} \end{array} \right] \\ \text{SUBJ } \langle [1] \rangle \\ \text{COMPS } \langle \rangle \end{array} \right] \right]$$

The crucial property of this feature structure is that the second member of the ARG-ST list does not appear in the COMPS list. To allow ASRCs we

simply need to allow the second member of the ARG-ST list to have a SLASH feature with an appropriate value. What sort of value is this? We assume that *which* has something like the following syntactic and semantic properties:

$$(61) \left[\begin{array}{l} \left[\begin{array}{l} \text{LOCAL} \left[\begin{array}{l} \text{CAT NP} \\ \text{CONT} \left\{ \begin{array}{l} \textit{param} \\ \text{INDEX [j]} \\ \text{RESTR [1]} \{ \textit{non - person(j)}, [j] \approx [i] \} \end{array} \right\} \end{array} \right] \\ \text{REL} \left\{ \begin{array}{l} \textit{param} \\ \text{INDEX [i]} \\ \text{RESTR [1]} \end{array} \right\} \end{array} \right] \end{array} \right]$$

This ensures that the index in the CONTENT of *which* is a non-person, which includes events/states, and that it is anaphorically dependent on the index that is its REL value (which, as with all relative clauses, is identified with the index of the antecedent). The value of SLASH is a set of local feature structures. Thus, to allow ASRCs we need to allow the LOCAL value of (61) to appear in the SLASH value of the missing complement. In other words, we need to flesh out (60) as (62), where the LOCAL value of (61) is abbreviated as NP_{j, j*si*}.

$$(62) \left[\begin{array}{l} \text{SS | LOCAL | CAT} \left[\begin{array}{l} \text{HEAD} \left[\begin{array}{l} v \\ \text{AUX +} \end{array} \right] \\ \text{SUBJ} <[1]> \\ \text{COMPS} <> \end{array} \right] \\ \text{ARG - ST} <[1], \text{XP}_j[\text{SLASH} \{(\text{NP}_j, j \approx i)\}] > \end{array} \right]$$

The local feature structure within the value of SLASH is within round brackets, indicating that it is optional. If this option is not taken, we have an auxiliary complement ellipsis sentence. If it is taken, we have an ASRC. The optional SLASH value is coindexed with the missing complement but it is an NP and hence will generally differ from the missing complement. On this analysis, ASRCs involve the type of gap assumed in the analysis of examples like (58) outlined in Bouma, Malouf and Sag (2001: 26), which Webelhuth (2008) calls a ‘dishonest gap’.

If the missing complement has a non-empty SLASH value, standard constraints will ensure that this SLASH value is passed up the tree, and the result will be an ASRC. The top of the ASRC dependency will involve the same mechanisms as other NRRCs. With these mechanisms, we will have structures like the following:

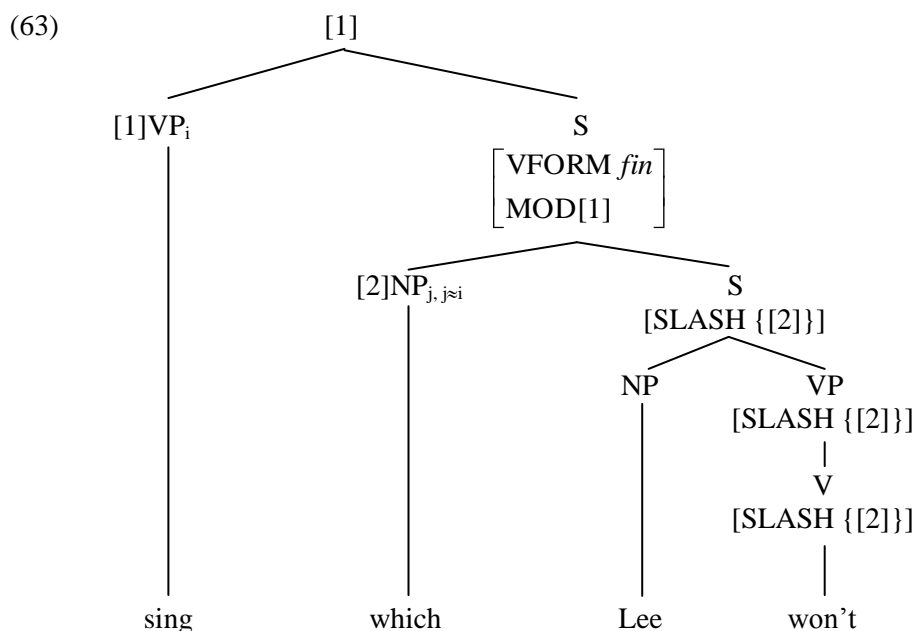

The crucial feature of this structure is that the index which is associated with the missing complement is anaphorically dependent on the antecedent. This is a result of the properties of auxiliaries and *which* and constraints on *wh*-relative clauses.

Like the other analyses this analysis predicts that ASRCs are subject to island constraints because it involves the SLASH feature and for HPSG island constraints are constraints on this feature. However, this analysis is superior to the other analyses in a number of ways.

Firstly, unlike the first and third analyses it treats *which* as the ordinary nominal *which*, which appears in other NRRCs. It requires the assumption that *which* can have eventive/stative index but this is required independently by examples like (4) and (5).

Secondly, unlike the other analyses, it only allows an auxiliary complement gap in an ASRC because an optional property of auxiliaries with a missing complement is responsible for the existence of the construction.

Thirdly, unlike the first analysis, it has no difficulty in ruling out examples with a VP filler such as (46)-(48) because it does not assume that *which* may be a VP.

Fourthly, again unlike the first analysis, it does not suggest that infinitival *to* or *not* should be possible before *which* as in (51) and (53) because it does not assume that *which* may be a VP.

Finally, it predicts the existence of complex examples with one gap in an auxiliary complement position and one in a nominal position, such as (64).

- (64) Kim has often ridden a camel, which most people haven't ____, and some consider ____ too dangerous.

Such examples are unexpected on all the other analyses since for all of them the two conjuncts have different SLASH values, the first being [SLASH {VP}] and the second [SLASH {NP}]. Within the analysis we are proposing, both are [SLASH {NP}].

A further point to note about this analysis is that it predicts that it should be possible to have not just *which* but other anaphoric fillers associated with an auxiliary complement gap. The following naturally occurring examples suggest that both *that* and *this* may occur.

- (65) a. They can only do their best and that they certainly will ____.
(http://www.britishcycling.org.uk/web/site/BC/gbr/News2008/200807018_Jamie_Staff.asp)
- b. Now if the former may be bound by the acts of the legislature, and this they certainly may ____, ...
(Thomas Christie (1792) *The Analytical review, or History of literature, domestic and foreign, on an enlarged plan*, p503 (Princeton University))
- c. It was thought that he would produce a thought provoking chapter, and this he certainly has ____.
(J. B. Cullingworth, ed. *British planning: 50 years of urban and regional policy*/, Continuum International Publishing Group, 1999, p13).

It does not seem to be possible to have *it* as a filler in an example like an ASRC:

- (66) a. *Kim will sing, but it Lee won't ____.
b. *Kim is clever, but it Lee isn't ____.
c. *Kim is in Spain, but it Lee isn't ____.

However, it seems to be generally impossible to have *it* as a filler:

- (67) *Kim likes beer, but it Lee doesn't like ____.

It looks, then, as if we don't need any special statement to rule out the examples in (66).

7. Further analyses and data

It seems to us that the filler gap analysis that we proposed in the last section is clearly superior to the other three analyses which we discussed. There are, however, some further analyses that should be considered and also some further relevant data. Both analyses involve the idea that *which* in ASRCs is not only the ordinary *which* but is associated with a nominal gap.

The first builds on the fact that many ASRCs have related examples with *do*. The following illustrate:

- (68) a. Kim will sing, which Lee won't ____.
b. Kim will sing, which Lee won't do ____.

(68a) contains an ASRC with an auxiliary complement gap, but (68b) contains an NRRC with a nominal gap. The gap may be replaced by *it* :

(69) Kim will sing, but Lee won't do it.

There are also related *wh*-interrogatives and pseudo-clefts:

- (70) A: What will Lee do ____?
B: Sing.
(71) What Lee will do ____ is sing.

Pairs of sentences like those in (68) might lead one to propose that ASRCs are ordinary NRRCs with a phonologically null variant of *do*.⁶ This might be compared to the phonologically null variant of *be* proposed in Borsley (2004) to accommodate comparative correlatives like the following:

(72) The more intelligent the students, the better the grades.

On this approach, (68a) will involve the following structure, where the bracketed *do* stands for an empty variant of *do*:

⁶ Alternatively one might propose that ASRCs involve a *do* that is deleted, invoking the deletion mechanism proposed in Beavers and Sag (2004).

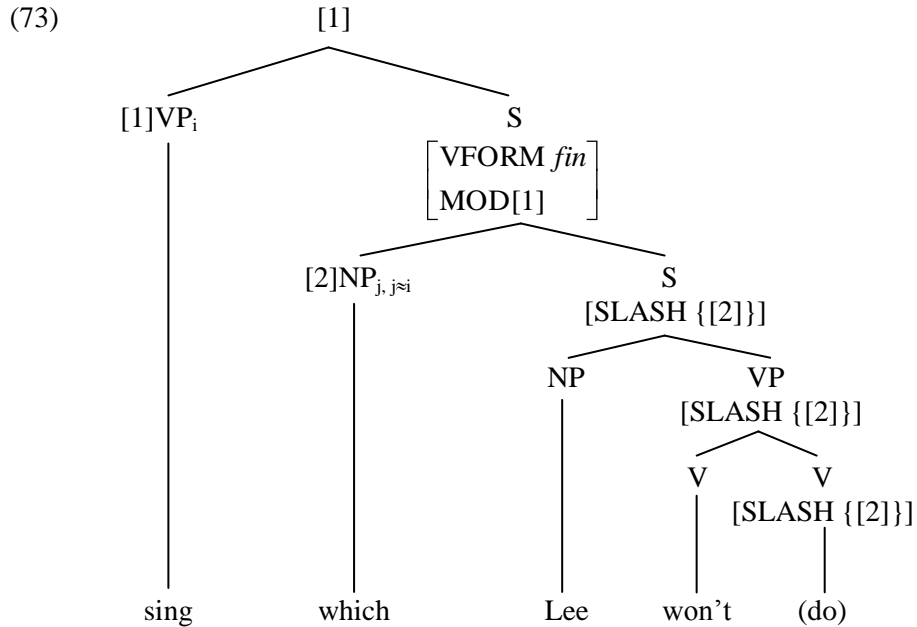

One point to emphasize about this approach is that the empty variant of *do* must have very specific properties. It cannot select just any nominal gap since this would allow the *wh*-interrogative in (74) parallel to that in (70) and the pseudo-cleft in (75) parallel to that in (71).

(74) *What will Lee ___?

(75) *What Lee will ___ is sing.

It will in fact have to select a gap with the LOCAL feature in (61). More importantly, it is only ASRCs with a verbal antecedent that have a paraphrase with *do*, but of course there are also ASRCs with a non-verbal antecedent such as the following:

(76) a. Kim is clever, which Lee isn't ___.

b. Kim is in Spain, which Lee isn't ___.

This means that this approach has essentially nothing to say about ASRCs with a non-verbal antecedent.

A more promising way of associating *which* in ASRCs with a nominal gap would be to stipulate that auxiliaries in addition to taking their normal complements (which may be unexpressed) may take a nominal gap. One argument in favour of this approach is that there seem to be cases elsewhere where a head takes a nominal gap but not an overt NP as a complement. As Bouma, Malouf and Sag (2001) point out, this seems to be the case with *assure* in examples like the following, highlighted by Kayne (1980) :

(77) This candidate, they assured me ___ to be reliable.

The following shows that the gap in (77) is in a position where an overt NP may not appear:

(78) *They assured me this candidate to be reliable.

In contrast it is not really clear whether dishonest gaps occur elsewhere. It looks, then, as if there may be a reason for preferring a nominal gap analysis. It can be argued, however, that it is more complex than our dishonest gap analysis. The nominal gap analysis introduces a completely new option as complement of auxiliaries whereas our analysis just allows two different values for one feature within a single option. Both approaches involve a disjunction, but ours seems simpler.

There is some further data that seems relevant here.⁷ As is well known, auxiliaries allow what is known as pseudo-gapping. In addition to appearing with no complement they appear with what looks like an elliptical complement, a phrase which is interpreted as if it were part of an ordinary complement. Consider, for example, the following:

(79) Kim criticized Lee, but he didn't ___ Sandy.

As we have indicated, a verb is missing from the second conjunct. It is possible to have more than just a verb missing, as the following from Culicover and Jackendoff (2005: 293) indicates:

(80) Robin will cook the potatoes quickly, and Leslie will ___ the beans ___.

Pseudo-gapping is restricted in various ways. For example, the following from Lasnik (1999) suggest that the post-auxiliary constituent may not be an AP:

- (81) a. *You probably just feel relieved, but I do ___ jubilant.
b. *Rona sounded annoyed, and Sue did ___ frustrated.

It also seems from the following examples from Culicover and Jackendoff (2005: 293, 294) that it is not possible with *to*:

- (82) a. *Robin will try to cook the potatoes, and Leslie will try to ___ the beans.

⁷ This was brought to our attention by Greg Stump.

- b. *Whenever you want to ___ the salad, first go ahead and taste the soup.

Pseudo-gapping is relevant in the present context because for many examples there is a similar example in which the conjunction is replaced by *which*. Thus, corresponding to (79) and (80) we have the following:

(83) Kim criticized Lee, which he didn't ___ Sandy.

(84) Robin will cook the potatoes quickly, which Leslie will ___ the beans ___.

These examples relate to pseudo-gapping clauses in the same way as ASRCs relate to auxiliary complement ellipsis clauses.

It seems, then, that there are two kinds of ellipsis with auxiliaries: auxiliary-complement ellipsis, where the whole complement is missing, and pseudo-gapping, where the complement is elliptical. The latter is restricted in various ways but seems to be possible with most auxiliaries. Crucially, we have related non-restrictive relatives with *which* in both cases. If there were related examples with *which* in just one case, one might think that this is a separate phenomenon. As it is, it seems that the right view is that there are two types of ellipsis, both of which allow the crucial argument to have a non-empty SLASH value which may be realized as relative *which*. We think, then, that pseudo-gapping and related examples with *which* provide some support for the approach that we have developed to ASRCs.

8. Concluding Remarks

In this paper we have investigated the properties of ASRCs and developed a fairly simple analysis. Our analysis attributes ASRCs to an optional additional property of auxiliaries which have a missing complement. They allow a dishonest gap as their complement and this gives rise to a filler-gap mismatch. In addition to its other advantages this approach makes it easy to see how ASRCs could have arisen historically and how they might arise in the grammar of an individual. All that is required is the replacement of (60) by (62). This is a rather simple change.

REFERENCES

- Arnold, D. J. (2004), Non-restrictive relative clauses in construction based HPSG, in Stefan Müller (ed.), *Proceedings of the 11th International Conference on HPSG*, Stanford: CSLI Publications, 27-47.

- Arnold, D. J. (2007), Non-restrictive relatives are not orphans, *Journal of Linguistics* 43, pp. 271-309.
- Beavers, J, and I. A. Sag (2004), Coordinate ellipsis and apparent non-constituent coordination, in S. Müller (ed.), *Proceedings of the 11th International Conference on HPSG*, Stanford: CSLI Publications, 48-69.
- Borsley, R. D. (1980), Some anaphors that aren't, paper presented at the Autumn Meeting of the Linguistics Association of Great Britain, University of Surrey, September 17-19, 1980.
- Borsley, R. D. (2004), An approach to English comparative correlatives, in S. Müller (ed.), *Proceedings of the 11th International Conference on HPSG*, Stanford: CSLI Publications, 70-92.
- Bouma, G., R. Malouf and I. A. Sag (2001), Satisfying constraints on extraction and adjunction, *Natural Language and Linguistic Theory* 19, 1-65.
- Culicover, P. W. and R. Jackendoff (2005), *Simpler Syntax*, Oxford: Oxford University Press.
- Huddleston, R. and G. K. Pullum (2002), *The Cambridge Grammar of the English Language*, Cambridge: Cambridge University Press.
- Ishihara, R. (1984), Clausal pied piping: A problem for GB, *Natural Language & Linguistic Theory* 2, 397-418.
- Kayne, R. (1980), Extensions of binding and case-marking, *Linguistic Inquiry* 11, 55-91.
- Kim, J-B., and I. A. Sag (2002), Negation without head movement, *Natural Language & Linguistic Theory* 20, 339-412.
- Lasnik, H. (1999), Pseudogapping puzzles, in S. Lappin and E. Benmamoun (eds.), *Fragments: Studies in Ellipsis and Gapping*, Oxford: Oxford University Press, 141-74.
- Levine, R. D. (2010), Auxiliaries: *To's* company, unpublished paper, Ohio State University.
- Pullum, G. K. (1982), Syncategorematicity and English infinitival *to*, *Glossa* 16, 181-215.
- Ross, J. R. (1969), Auxiliaries as main verbs, in W. Todd (ed.), *Studies in philosophical linguistics* (Series 1). Evanston, IL: Great Expectations Press, 77-102.
- Warner, A. R. (2000), English auxiliaries without lexical rules, in R. D. Borsley (ed.), *The Nature and Function of Syntactic Categories*, New York: Academic Press.
- Webelhuth, G. (2008), A lexical-constructional approach to "movement mismatches", paper presented at the Fifth international Conference on Construction Grammar, The University of Texas at Austin, September 26-28, 2008.