

Adjuncts and the HPSG binding theory

Heike Walker

University of Frankfurt am Main

Proceedings of the 18th International Conference on
Head-Driven Phrase Structure Grammar

University of Washington

Stefan Müller (Editor)

2011

Stanford, CA: CSLI Publications

pages 227–247

Walker, Heike. 2011. Adjuncts and the HPSG binding theory. In Stefan Müller (ed.), *Proceedings of the 18th International Conference on Head-Driven Phrase Structure Grammar, University of Washington*, 227–247. Stanford, CA: CSLI Publications. DOI: 10.21248/hpsg.2011.13.



Abstract

The HPSG binding theory in Pollard and Sag (1994) cannot account for the binding-theoretic interaction between main clause and adjunct-internal elements. Following Hukari and Levine (1995), I claim that structural configurations must be taken into account. In this article, I present a revised version of Hukari and Levine's configurational relation called *v(alence-based)-c-command* and propose that Principle C must involve this relation in addition to the obliqueness-based relation of *o-command*. New data are provided that strongly support the proposed revision of the HPSG binding theory. Finally, I argue that Principle C is syntactic rather than pragmatic in nature.

1 Introduction

Binding theory accounts for the distribution of anaphors, personal pronouns, and R-expressions and defines the syntactic conditions under which coreference relations among linguistic expressions are obligatory, permitted, or prohibited. Various syntactic theories in the tradition of the Government and Binding theory, starting with Chomsky (1981) and Reinhart (1976, 1981, 1983), provide an account of coindexation possibilities in terms of the phrase structural relation of *c-command*. The HPSG binding theory presented by Pollard and Sag (1994) (henceforth P&S-94) rejects these configurational formulations and instead introduces a relation called *o-command* which is based on the relative obliqueness of arguments of the same head, as reflected in its ARG-ST list.¹ But this analysis faces a number of problems. For example, it fails to address the binding-theoretic interaction between elements in the main clause and elements within adjuncts. In this article, I present a revision of the HPSG binding theory that can account for these binding phenomena. I follow Hukari and Levine (1995), who claim that a configurational relation similar to *c-command* is needed in order to capture the binding behavior of adjunct-internal elements. To this end, they introduce a relation called *v(alence-based)-c-command* and propose that Principle C must involve this configurational relation in addition to the obliqueness-based relation of *o-command*. They show that the (anti)reconstruction effects as well as binding effects in VP topicalization fall out from this revised binding theory. However, as a formal definition in terms of the HPSG formalism, Hukari and Levine's formulation of *vc-command* is flawed. To remedy this deficiency, I propose a revision of *vc-command* that is compatible with the foundations of the HPSG framework. I provide new data that strongly support the proposed revision of the HPSG binding theory.

This article is structured as follows: I present a brief review of P&S-94's binding theory in section 2 and some of its problems concerning binding into adjuncts

[†]I would like to thank Bob Levine, Manfred Sailer, Gert Webelhuth, the audience at the HPSG conference, and three anonymous reviewers for helpful comments and discussion.

¹I employ here the feature ARG-ST as used in more recent work within the HPSG framework to replace the SUBCAT feature as used in P&S-94.

in section 3. In section 4, I give an outline of Hukari and Levine’s (1995) valence-based binding theory. After describing its deficiencies, I propose a new formulation of vc-command and explain how it accounts for the problematic data presented earlier. Section 5 shows some further empirical consequences of the revised binding theory, namely that it accounts for the (anti)reconstructions effects and for binding phenomena in extraposition, VP topicalization, and VP complements. Finally, in section 6, I briefly address the question of whether Principle C is pragmatic in nature, a claim that has often been made in the literature. I argue that the evidence provided in favor of these claims is not convincing enough to refute the syntactic nature of Principle C, which is also supported by psycholinguistic evidence.

2 Binding theory in P&S-94

The binding theory proposed by Pollard and Sag (1994) replaces the tree-configurational notion of c-command by a relation called o(bliqueness)-command, which is based on the relative obliqueness that obtains between arguments of the same head. Relative obliqueness is modeled by position on the ARG-ST list of some lexical head. The ordering corresponds to the traditional obliqueness hierarchy, with the subject (the least oblique element) appearing first (leftmost), followed by the primary object, the secondary object, and other, more oblique complements (in that order, if such exist). In the revised binding theory presented in chapter 6.8.3 of P&S-94, two relations, a general (“weak”) relation called o-command and a “strong” relation called local o-command, are defined as follows:

- (1) Let Y and Z be *synsem* objects with distinct LOCAL values, Y referential. Then Y *locally o-commands* Z just in case either:
 - i. Y is less oblique than Z; or
 - ii. Y locally o-commands some X that subcategorizes for Z.
- (2) Let Y and Z be *synsem* objects, with distinct LOCAL values, Y referential. Then Y *o-commands* Z just in case either:
 - i. Y is less oblique than Z; or
 - ii. Y o-commands some X that subcategorizes for Z; or
 - iii. Y o-commands some X that is a projection of Z (i.e. the HEAD values of X and Z are token-identical).

It follows from these definitions that local o-command is a special case of o-command; the cases of local o-command are just those cases covered by clauses (i) and (ii) of o-command. O-command serves as the basis of the o-binding relation:

- (3) Y (*locally*) *o-binds* Z just in case Y and Z are coindexed and Y (locally) o-commands Z. If Z is not (locally) o-bound, then it is said to be (*locally*) *o-free*.

The Binding Principles are formulated as follows:

- (4) i. Principle A. A locally o-commanded anaphor must be locally o-bound.
- ii. Principle B. A personal pronoun must be locally o-free.
- iii. Principle C. A nonpronoun must be o-free.

To illustrate this binding theory, consider the following ill-formed example:

- (5) * She_i believes that John likes Mary_i.

The ARG-ST list of the matrix verb *believes* consists of the pronoun *she* and the CP *that John likes Mary*, hence *she* (locally) o-commands the CP by definition (2i) (or (1i), respectively). By repeated application of (2ii) and (2iii), *she* o-commands the head daughter *that* of the CP, the head verb *likes* of the subclause, and finally the arguments of *likes*. Hence, *she* o-commands *Mary*. Since the two are coindexed, *Mary* is o-bound and Principle C is violated.

3 Problems with P&S-94's binding theory

P&S-94's nonconfigurational binding theory cannot account for the coindexation between main clause and adjunct-internal elements. Adjuncts are not selected by heads and thus do not appear on ARG-ST lists. Hence, they do not stand in obliqueness relations to arguments.² It follows that an adjunct is never (locally) o-commanded, and no element within it can ever be o-bound by an element outside of the adjunct. Consequently, P&S-94's theory cannot predict any Principle C effects involving nonpronominal NPs within adjuncts bound by arguments of the main clause.

But there is considerable evidence that adjuncts are transparent for binding purposes. First of all, a nonpronominal NP contained within a relative clause cannot be coreferential with an argument preceding the NP containing the relative clause, as illustrated in (6).³ Since a relative clause functions as a modifier, a name within

²As will become clear in the following discussion based on Hukari and Levine (1995), approaches in which adjuncts are added to the ARG-ST list, as for example van Noord and Bouma (1994) and Sag (2005), fail on empirical grounds since they cannot predict the complex cataphora asymmetries demonstrated below, for example the contrast between subject-based and object-based cataphora into *without*-adjuncts as shown in (7) and (8).

³During the discussion after the talk, Ivan Sag claimed that the acceptability of the ungrammatical examples provided in this article would improve in certain contexts or, for example, when the name is more deeply embedded, as in (i):

- (i) She_i was grateful to ALL the people who contributed to the campaign that had guaranteed Lola_i's election to public office.

Sag proposes no non-structural analysis of the effect. Bob Levine replied that the reason for this effect could be processing and memory effects. Be that as it may, sentences such as in (i) contain a number of structural properties simultaneously, like constrictive focus on *all* and the doubly embedded relative clauses, that might be structurally responsible for the weaker effect of Principle C as well. Moreover,

it is not o-commanded by a preceding argument of the matrix clause, and P&S-94's binding theory incorrectly does not predict a Principle C violation for these sentences.⁴

- (6) a. * She_i admires the people [who work with Lola_i].
(Reinhart, 1983, p. 102)
- b. * I sent her_i many gifts [that Mary_i didn't like] last year.
(Culicover and Rochemont, 1990, p. 29)
- c. * I told him_i about your new argument [that supports John_i's theory].
(Fox and Nissenbaum, 2000, p. 5)

Other types of adjunct clauses also constitute a problem for the binding theory. As observed by Hukari and Levine (1995, 1996), an R-expression within a *without*-clause may not be coreferential with the subject pronoun of the matrix clause:

- (7) a. * They_i went into the city [without anyone noticing the twins_i].
b. * They_i went into the city [without the twins_i being noticed].
c. * They_i could never do anything [without the twins_i feeling insecure about it].

However, there is an asymmetry between subject and object antecedents. While cataphora into the *without*-adjunct is impossible when the pronoun is in subject position (as in (7)), it is possible when the pronoun is an object of the main clause, as shown in (8).

- (8) a. You can't say anything to them_i [without the twins_i being offended].
b. You can't say anything about them_i [without Terry criticizing the twins_i mercilessly].
c. I lectured her_i for an hour [without a single one of my points getting through to Terry_i].
d. I was able to criticize him_i [without anyone realizing that Robin_i was the object of my scorn].
e. I was able to criticize her_i [without anyone realizing that I was talking about Robin_i].

as Bob Levine has pointed out to me, the necessary strong destressing of *Lola* to get the coreference might turn the name into a kind of epithet, which must be treated differently than regular names and descriptions with respect to the binding principles.

⁴Note that the original formulation of Pollard and Sag's binding theory (1992; 1994) can account for these data because o-command is defined in terms of a domination relation. Thus, the pronoun locally o-commands the phrase which dominates the nonpronominal NP within the relative clause so that the latter is o-commanded and hence o-bound by the coindexed pronoun in violation of Principle C. However, these definitions of the binding theory fail to predict binding relations in certain unbounded dependency constructions. In addition, Pollard and Sag (1994, p. 277) suggest to "minimally extend local o-command in such a way that unexpressed reflexive subjects of VP and predicative complements become subject to Principle A". That is why they revise the definitions and provide a totally nonconfigurational binding theory in chapter 6.8.3.

This subject/object-asymmetry can also be found in sentences with other types of adjunct clauses:

- (9) a. * She_i always gets angry [if/when Kim_i is criticized].
 b. * He_i always stops [before Freddy_i says something stupid].
 c. * He_i came into the room [as quickly as John_i could].
 ((9c) from Culicover and Rochemont (1990, p. 33))
- (10) a. Sara always stops him_i [before/when Freddy_i acts stupid].
 b. We always console her_i [when Kim_i is criticized].

The binding theory in P&S-94 does not predict these cataphora asymmetries. According to its definitions, all of the sentences in (7)-(10) should be equally grammatical.

Hukari and Levine (1995) argue that the *without*-clause has the status of a VP-adjunct by applying conventional tests for VP-adjuncthood (coordination, proform replacement, and displacement) that clearly suggest a structural difference between *without*-clauses and complements on the one hand, and between *without*-clauses and sentential adjuncts on the other. These structural differences are reflected and thus supported by contrasts in coreference possibilities. Compare the sentences in (8) to those in (11).

- (11) a. * You can't tell them_i [that the twins_i are being offensive].
 b. * You can't tell them_i [that people are irritated at the twins_i].

Cataphora is possible from an object pronoun into a *without*-adjunct, as in (8), but not into a *that*-clause complement, as in (11). Assuming a configurational binding theory that is based on a c-command relation, Principle C prohibits the coreference in (11) since the nonpronominal is in an object clause which is clearly c-commanded by the coindexed pronoun *them*.⁵ The fact that the sentences in (8)

⁵An anonymous reviewer claimed that there are variants of (11), such as in (i), which are (more) acceptable. Similarly, Ivan Sag (p.c.) provided the example in (ii), among others, as a counterexample to a structural version of Principle C.

- (i) ? You can't require/expect of them_i that the twins_i should win every single match they_i play.
 (ii) I've never been able to explain to her_i that Betsy_i's gophers destroyed my lawn each spring.

If the PP containing the pronoun was less oblique than the complement clause containing the coindexed name, these examples would be problematic for both, the binding theory proposed here as well as for P&S-94's theory based on o-command. However, I argue that the PP is indeed more oblique than the *that*-clause. The following paradigm shows that only the direct object can be passivized:

- (iii) a. You required that of them.
 b. That was required of them.
 c. * They were required that of.

The argument structure of *require* seems to be: ARG-ST <NP, NP, PP_{of}>. When the direct object is a *that*-clause, as in the sentences above, it is probably linearized last because of its heaviness. But

are grammatical indicates a lack of a c-command relation in those examples and hence a structural difference between the complement clause on the one hand and the adjunct clause on the other.

Moreover, the difference in coreference possibilities between (12) and (13) is an indication of the structural difference between *without*-adjuncts and adjuncts that are clearly sentential.

- (12) *They_i could never do anything [without the twins_i feeling insecure about it].
- (13) They_i hadn't been on the road for half an hour [when the twins_i noticed that they had forgotten their money, passports and ID].

In both sentences, the relevant NP *the twins* appears within an adjunct clause and is coindexed with a pronoun in the subject position of the main clause. But only when the NP is within the sentential adjunct is coreference possible (see (13)). When it is inside the VP-adjunct, as in (12), coreference is not allowed. This contrast cannot be predicted by an obliqueness-based binding theory. Since neither sentential nor VP-adjuncts appear on ARG-ST lists, the nonpronominal NP *the twins* is not o-commanded and thus not o-bound by the subject pronoun in either case. The sentences should be equally grammatical. In terms of c-command, however, (12) is ruled out by Principle C since the subject pronoun c-commands the coindexed nonpronominal inside the VP-adjunct. The sentential adjunct in (13) is not c-commanded by the subject and thus the sentence is correctly predicted to be grammatical.

Finally, the subject/object-asymmetry between the sentences in (7) and those in (8) also indicates a c-command relation between the subject of the matrix clause and the adjunct in (7), but a lack of a c-command relation between the complement of the matrix verb and the adjunct in (8). It thus supports the assumption that the *without*-clause is a VP-adjunct.

All these data provide evidence that there are some binding-theoretic interactions between main clause elements and elements within adjuncts. Specifically, there is a subject/object-asymmetry in cataphora possibilities. But, as shown in detail, the HPSG binding theory in P&S-94 does not capture these effects. It has to be modified in order to rule out cataphora into certain adjuncts. One possible solution, which was specifically addressed by Hukari and Levine (1995), would be to add adjuncts to the ARG-ST list in the style of van Noord and Bouma (1994) or Sag (2005), in order to preserve P&S-94's purely obliqueness-based approach. The VP-adjuncts would have to be placed between the subject and the complements. In this position, elements within the adjunct would be o-commanded by the subject but not by any objects, and the cataphora asymmetries would be correctly predicted. Sentential adjuncts, however, would have to be treated differently. Since

with the underlying argument structure, these sentences do not constitute a problem for a binding theory based on o-command or vc-command.

they do not show any Principle C effects with main clause elements, they should not be placed on the ARG-ST list.

Hukari and Levine (1995) argue that this approach is problematic since this position on the ARG-ST list is implausible for adjuncts. There is ample cross-linguistic evidence, for example Keenan and Comrie's (1977) tests for relativizability which have led to the formulation of the accessibility hierarchy, that adjuncts are placed at the lower end of the obliqueness hierarchy, being more oblique than subjects, direct objects, and other objects. This is also supported by linearization facts, as the examples from Hukari and Levine (1995) in (14) show.

- (14) a. Harry talked [to Margaret] [about the problem] [without paying attention to the time].
b. * Harry talked [to Margaret] [without paying attention to the time] [about the problem].
c. * Harry talked [without paying attention to the time] [to Margaret] [about the problem].
d. Harry talked [about the problem] [to Margaret] [without paying attention to the time].
e. * Harry talked [about the problem] [without paying attention to the time] [to Margaret].
f. * Harry talked [without paying attention to the time] [about the problem] [to Margaret].

The unmarked linear order seems to be that adjuncts come last. Even Pollard and Sag (1987, p. 181) concluded their discussion about the position for adjuncts and complement PPs and APs with the remark that “[...] adjuncts are more oblique than complements”.

However, there is an alternative solution, which was proposed by Hukari and Levine (1995) and which I adopt. This approach is presented in the next section.

4 A valence-based binding theory

In order to account for the cataphora effects with elements inside of adjuncts, Hukari and Levine (1995) suggest to supplement the definitions of the HPSG binding theory with the new structural relation of *vc-command* and reformulate Principle C so that it is based on both, *o-command* and *vc-command*. In the following, I will first introduce Hukari and Levine's valence-based binding theory. I will then propose a revision of the relation of *vc-command* and demonstrate that it captures all the binding effects depicted above.

Hukari and Levine (1995) propose the following command relationship in terms of configuration. Since it is similar to *c-command* but based on the valence of an element, they call it *v(alence-based) c-command*.

(15) **v(alence-based) c-command:**

Let α be an element on a valence list γ and α' the DTRS element whose SYNSEM value is structure-shared with α . Then if the constituent that would be formed by α' and one or more elements β has a null list as its value for γ , α vc-commands β and all its descendants.

This relation is added to the definitions of P&S-94's binding theory; that is, it exists in addition to o-command, and Principle C is replaced by the following formulation, which I slightly adapted here:

(16) **Principle C:** A nonpronominal must neither be bound under o-command nor under a vc-command relation.

In essence, a subject vc-commands the VP and all its descendants, and a complement vc-commands all its sister constituents and their descendants. So, crucially, vc-command is a relation that exists between a subject and VP-adjuncts (including all descendants) but not between complements and VP-adjuncts. Moreover, it exists between a subject or complement and any adjuncts within more oblique complements. The revised Principle C prohibits the binding of nonpronominals under vc-command as well as o-command, thus causing the desired effects.

While I agree with the gist of Hukari and Levine's definition of vc-command, its formulation is conceptually flawed, especially as concerns the modality in the formulation, which renders it extremely suspect. In order to determine whether or not a given feature structure is legal, one has to compare it to other possible feature structures and identify whether a certain relationship holds between them. That is somewhat strange for a formalism that employs the kind of foundations that HPSG adopts. The modality in the definition might not be formally compatible with and, moreover, it might not even be formulable in a constraint-based framework like HPSG.⁶ I therefore propose the following refinement:

(17) **vc-command (revised)**⁷ :

Let α, β, γ be *synsem* objects, and β' and γ' signs such that β' : [SYNSEM β] and γ' : [SYNSEM γ]. Then α vc-commands β iff

- i. γ' : [SS|LOC|CAT|VAL|SUBJ $\langle\alpha\rangle$] and γ' dominates β' , or
- ii. α locally o-commands γ and γ' dominates β' .

⁶This was also endorsed by one of the anonymous reviewers, whom I would like to thank for his or her additional comments.

⁷Stefan Müller has suggested to change the requirement that α be on the SUBJ-list of γ' into the requirement that it be the first element on the ARG-ST list so that the definition would also apply to other languages like pro-drop languages. Along these lines, Olivier Bonami has proposed the following formulation as an alternative to (17i):

(i') γ' : [SS|LOC|CAT|ARG-ST $\langle\alpha, \dots\rangle$] and γ' is the HEAD-DTR of a phrase that dominates β' .

On closer inspection, however, it becomes evident that this definition fails to account for the sentences in (7). I leave it to future work to carefully scrutinize the proposal and investigate its empirical relevance. I am grateful to Stefan Müller and Olivier Bonami for their comments.

This revised formulation of vc-command is formally and technically clean. Moreover, it emphasizes the primacy of the subject. The subject is the least oblique and (in English) the sole obligatory argument of the verb and is in a superior structural position. This special status is reflected in its binding behavior. Subjects are strong binders; some languages possess anaphors that can only be bound by subjects.

The revised binding theory predicts all of the data provided above. The ungrammatical sentences are now correctly ruled out by Principle C. First of all, in the sentences in (6), the pronoun locally o-commands the NP containing the relative clause because they both appear on the ARG-ST list of the main verb. The NP in turn dominates the nonpronominal NP inside the relative clause so that the latter is vc-commanded by the coindexed pronoun in violation of Principle C.

Next, consider again the sentences in (7). The structure of (7a), repeated here in (18a), is given in (18b). The SYNSEM value of the subject pronoun *they* is structure-shared with the element on the SUBJ list of the VP. Under the assumption that the *without*-clause is adjoined to VP, the adjunct is dominated by the higher VP node. But then the nonpronominal NP *the twins* is also dominated by that VP. It follows from clause (i) of the definition in (17) that the NP *the twins* is vc-commanded by the subject pronoun. Since the two are coindexed, Principle C is violated.

(18) a. * *They_i went into the city [without anyone noticing the twins_i].*

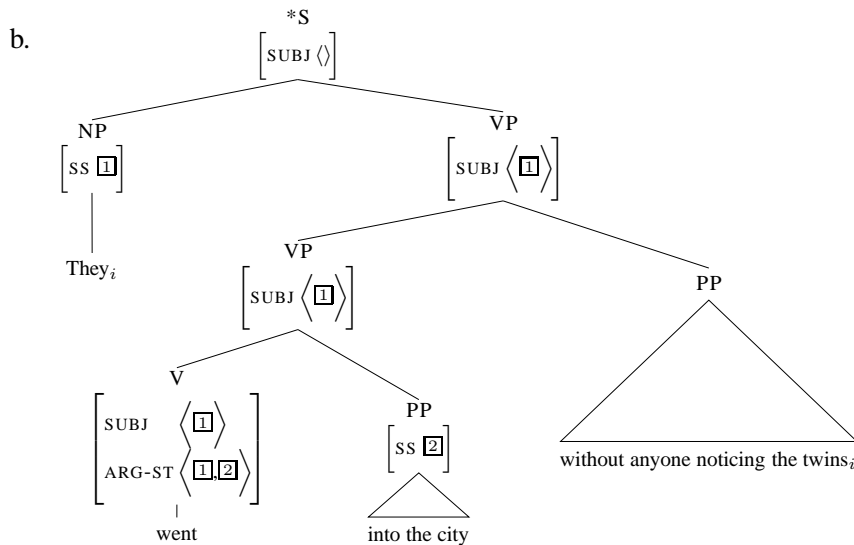

There is no Principle C effect in the sentences in (8) since the relevant non-pronominal is not vc-commanded by the coindexed pronoun. (17i) does not apply since the pronoun is an object and not a subject, and (17ii) does not apply since the *without*-clause does not appear on the ARG-ST list of the main verb and therefore is not locally o-commanded by the pronoun.

The relevant nonpronominal in (13) is not bound by the subject pronoun, either, under the assumption that the adjunct containing the nonpronominal is a sentential adjunct. It adjoins to the S node, which already has an empty SUBJ list.

5 Further consequences of the revised binding theory

The binding theory that incorporates both obliqueness and configuration into the formulation of Principle C has additional desirable consequences. First of all, as Hukari and Levine (1995) noticed, it can account for phenomena known as (anti)reconstruction effects, first observed by van Riemsdijk and Williams (1981) and taken up by Lebeaux (1988), in which adjuncts and complements within extracted arguments show different behavior with respect to Principle C. When a coindexed name appears inside a complement, a Principle C violation is maintained when the NP including the complement is extracted, as shown in (19). When the name is in an adjunct, as in (20), a Principle C violation is circumvented when the NP including the adjunct is fronted.

- (19) a. * He_i denied the claim [that $John_i$ likes Mary].
 b. * Whose claim [that $John_i$ likes Mary] did he_i deny t ?
 (20) a. * He_i denied the claim [that $John_i$ made].
 b. Which claim [that $John_i$ made] did he_i later deny t ?

With the new Principle C being based on both relations, o-command and vc-command, these effects can be straightforwardly explained. (19a) is ruled out because the pronoun (locally) o-commands the NP *the claim that John likes Mary* on the ARG-ST list of *denied*. Since the coindexed name *John* is within the clausal complement of *claim*, it is also o-commanded by the pronoun *he* by repeated application of clauses (ii) and (iii) of P&S-94's definition of o-command (see (2)). (20a) is correctly predicted to be ungrammatical because the name is vc-commanded by the coindexed pronoun (by (17i) or (17ii)). It is the o-command relation that is responsible for the ungrammaticality of (19b). Recall that o-command is defined in terms of "projection of", or shared HEAD features. As shown in the tree structure in (21), *he* locally o-commands the gap on the ARG-ST list of *deny*.

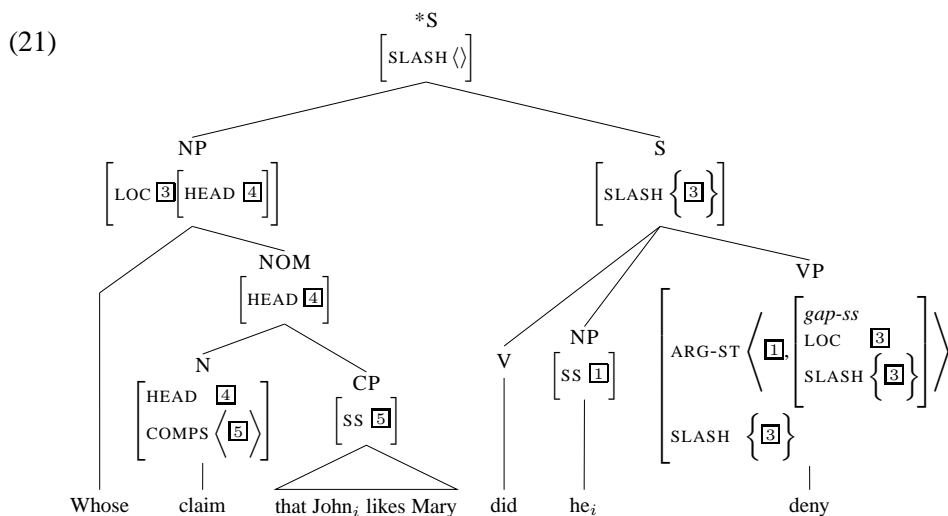

Since the gap structure-shares its LOCAL value with the filler (the NP *whose claim that John likes Mary*), its HEAD value is identical with the HEAD value of the filler as well as its head daughter (*claim*). Thus, by repeated application of (2ii) and (2iii), *he* o-commands *claim*, the clausal complement of *claim*, and finally the coindexed name *John* in violation of Principle C. The tree structure for (20b) is shown in (22). Although the head of the filler, *claim*, is o-commanded by the pronoun *he* in the same way as in (19b/21), the o-command relation does not extend to the relative clause because relative clauses are not selected by the head that they modify. So, *John* inside the relative clause is not o-commanded by the matrix clause subject *he*. It is also not bound under a vc-command relation. In order for *John* to be vc-commanded by *he*, it would have to be dominated by a constituent that is locally o-commanded by *he* (according to (17ii)) or by a constituent on whose SUBJ list the pronoun appears (i.e., the VP with the head *deny*) (according to (17i)). But there is no way in which such domination relations can exist, independent of which analysis is assumed for unbounded dependency constructions.

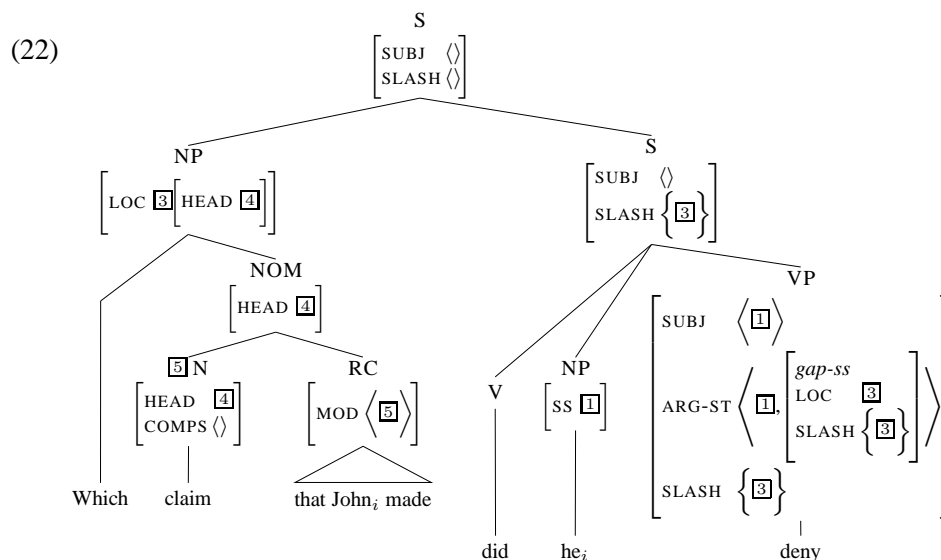

I would like to emphasize the crucial difference between o-command and vc-command at this point. The relation of vc-command, being defined in terms of domination, breaks off at the gap site. It is not passed on from a gap to its filler. The o-command relationship, on the other hand, is passed on since it is defined in terms of the relation “projection of”, or shared HEAD features.

Observations similar to the (anti)reconstruction effects can be found in extraposition constructions. Adjunct extraposition circumvents a Principle C violation, but complement extraposition does not, as the examples from Fox and Nissenbaum (1999, p. 139) demonstrate:

- (23) a. ??/* I gave him_i a picture [from John_i's collection] yesterday.
 b. I gave him_i a picture yesterday [from John_i's collection].

- (24) a. * I gave him_i a picture [of John_i's mother] yesterday.
 b. ??/* I gave him_i a picture yesterday [of John_i's mother].

It should be clear by now how the revised Principle C rules out the nonextraposed sentences. The nonpronominal is vc-commanded by the coindexed pronoun when it appears within an adjunct, as in (23a), and o-commanded when it is inside a complement, as in (24a). The extraposed variants are shown in the (b)-sentences. There are different approaches to extraposition in HPSG. Several movement-based analyses treat extraposition as a nonlocal dependency using the same kind of mechanism that accounts for extraction to the left (e.g., Keller, 1994; Müller, 1999). For relative clause extraposition, an anaphoric approach assuming simple adjunction of the extraposed adjunct is proposed by Kiss (2005). Crysmann (To appear) suggests a combination of the two approaches for complement clause and relative clause extraposition in German. No matter which analysis is applied, the binding theory proposed here interacts with any of them in the desired way. For this reason, the extraposition mechanism is not further specified in the tree structure in (25), which shows the syntactic structure of the sentence in (24b) with the extraposed complement. Since a complement, whether extraposed or not, is selected by a head, it appears on the ARG-ST list of that head, where the binding principles can be applied in the familiar way. So, *him* (locally) o-commands the NP *a picture* on the ARG-ST list of *gave*, and through a chain of HEAD identities and selection (see (2ii) and (2iii)) it finally o-commands the coindexed name *John* within the extraposed PP, and Principle C is violated.

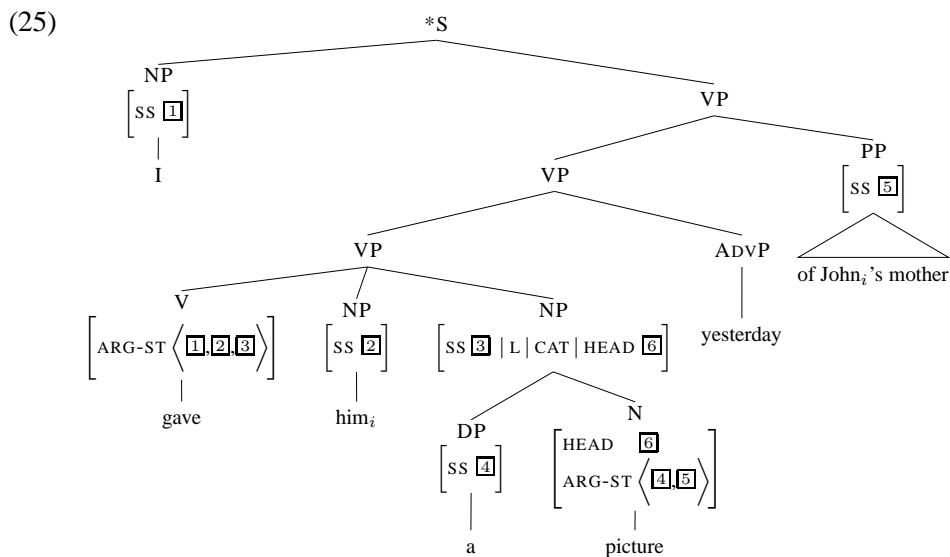

Elements within adjuncts, on the other hand, are never o-commanded by arguments outside of the adjunct, as I have explained in detail above. The nonextraposed version in (23a) is ruled out by Principle C under vc-command. The extraposed adjunct in (23b), however, escapes a vc-command relation. Even though the pronoun

him locally o-commands the NP *a picture*, it does not vc-command the coindexed name *John* because, under the assumption that constituents extraposed from within VP may adjoin to the VP, the NP *a picture* does not dominate the extraposed PP containing *John*. Note that when the pronoun is in the subject position, as in (26), adjunct extraposition does not circumvent a Principle C violation. This fact supports the suggestion by Culicover and Rochemont (1990), among others, that a constituent extraposed from an object must be adjoined to VP rather than S. Under this assumption, the sentences in (26) are correctly ruled out by the binding theory proposed here since the subject pronoun vc-commands the coindexed name within the extraposed adjunct.

- (26) a. * *She_i invited many people to the party [that Mary_i didn't know].*
 (Culicover and Rochemont, 1990, p. 28)
- b. * *She_i told many people about the concert [who Mary_i made nervous].*
 (Guéron and May, 1984, p. 10)

As the examples from Hukari and Levine (1995) in (27) demonstrate, (anti)reconstruction effects are not found in VP topicalization, an observation cited by Huang (1993) which goes back to Chomsky. In contrast to argument extraction (cf. (20b)), a Principle C violation is not circumvented when a VP is fronted that includes an adjunct that contains a name coindexed with the matrix subject pronoun.

- (27) a. * *... and leave office without anyone ever trusting Nixon_i he_i did.*
- b. * *... and gather injunctions until Richardson_i had every crook behind bars he_i knew he_i would.*

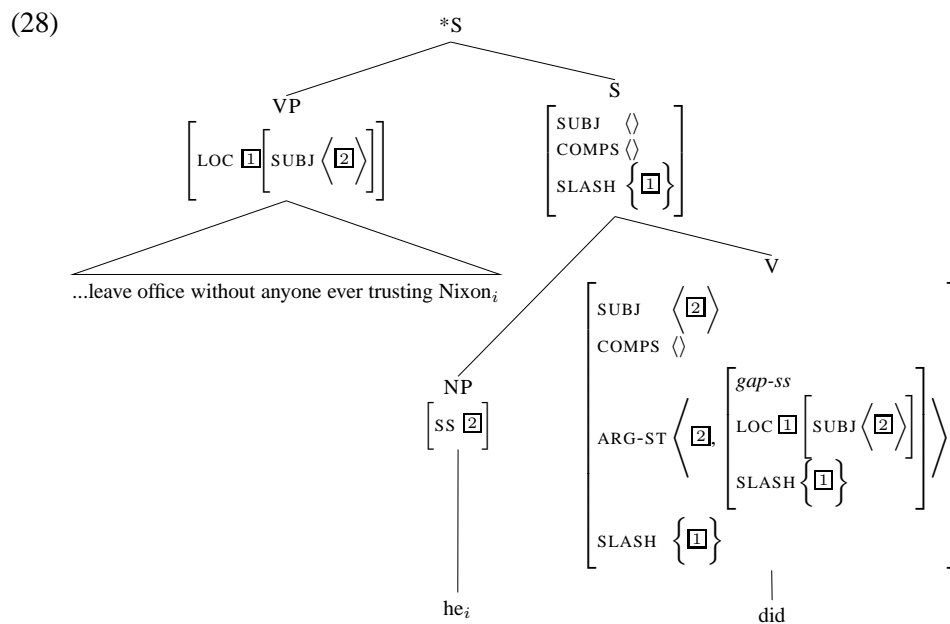

On Huang's account, these contrasts follow from the VP-internal Subject Hypothesis. But the same effects also fall out from the proposed revision of the HPSG binding theory, as noticed by Hukari and Levine (1995). As shown in (28), the SUBJ specification of the fronted VP is structure-shared with the SUBJ specification of the VP gap, which in turn is structure-shared with the SYNSEM value of the subject pronoun *he*. Therefore, all these elements share their indices. Since the SUBJ specification of the fronted VP *vc*-commands any constituent dominated by that VP (according to (17i)), no element within it may bear the same index, as required by Principle C.

Finally, another outcome of the revised Principle C is that it correctly predicts the ungrammaticality of sentences as in (29). The offending name is in a relative clause that is contained within a VP complement. It is bound by the pronoun complement of the matrix verb under *vc*-command (see (17ii)), but not under *o*-command.

(29) * John seems to her_i to have made a claim which Mary_i resented.

To sum up, I have shown that the binding theory proposed here accounts for all of the problematic data given above concerning the behavior of adjunct-internal elements with respect to Principle C. In addition, it has some further benefits. It offers an account of the (anti)reconstruction effects and of the binding behavior in sentences with extraposition, VP topicalization, and VP complements. In the following section, I will address the question of whether Principle C is pragmatic in nature and provide evidence that refutes this claim.

6 Is Principle C pragmatic in nature?

It has been repeatedly suggested in the literature that Principle C should be explained in semantic/pragmatic rather than in syntactic terms (cf. Bolinger (1979); Bresnan (2001); Bouma et al. (2001); Kuno (1975); Bickerton (1975); McCray (1980); among others). Bresnan (2001) and Bouma et al. (2001), for example, provide contrasting pairs such as (30) and (31) to demonstrate that Principle C cannot be based on grammatical structure, or more specifically *c*-command, because in that case the (b)-sentences, which they assume to be structurally identical to the sentences in (a), would be incorrectly ruled out. They therefore suggest that pragmatic effects, theme/rheme conditions, and information structure must be taken into account, but they do not provide a specific analysis. Moreover, I am not aware of a pragmatic theory which covers all Principle C effects that has been integrated into HPSG.

- (30) a. * She_i was last seen when Lola_i graduated from high school.
 (cited from Reinhart (1983, p. 104) in Bresnan (2001, p. 227))
 b. He_i's impossible, when Ben_i gets one of his tantrums.
 (cited from Bolinger (1979, p. 302) in Bresnan (2001, p. 227))

- (31) a. * He_i always gets angry when Sandy_i is criticized.
 (cited from Hukari and Levine (1996, p. 490) in Bouma et al. (2001, p. 44))
- b. He_i gets angry whenEVER the people Sandy_i loves criticize him.
 (Bouma et al., 2001, p. 44)

The proposals that have been provided in functionalist terms, for example, Kuno (1975), Bickerton (1975), Bolinger (1979), and McCray (1980), cannot adequately account for the coreference options of nonpronominals, as already noticed by Reinhart (1983). She carefully scrutinizes these approaches, notes that they either fail, are vague, or “not fully formalisable” (p. 98), and concludes that “[...] the fact that when there is a discrepancy between domain relations and functional relations coreference options follow the syntactic requirements, indicates that coreference restrictions are determined by syntactic properties” (p. 100).⁸

In addition, as far as I am aware, the proponents of the pragmatic approach have not provided any careful syntactic analyses of the examples they discuss. Thus, they do not show that these data actually fall within the scope of Principle C and accordingly falsify a configurational binding theory. In the following, I will show that under a correct syntactic analysis of the sentences such as in (30) and (31), a configurational binding theory can indeed account for the contrast in coreference possibilities.

Consider Bolinger’s example in (30b). In addition to it, Bolinger (1979, p. 302) provides the example shown in (32a), in which the temporal adjunct appears in the first position of the sentence. An adequate structural description is given in (32b), in which the *when*-clause is adjoined to S. Since such adjunct structures exist, and since, in principle, adjunct configurations are symmetrical, it follows that (33) is a plausible analysis for the sentence in (30b); that is, the sentence-final *when*-clause is also analyzed as a sentential adjunct.⁹ This is additionally supported by phonological considerations. The sentence must be pronounced with an intonational break between the main clause and the subclause, which is typically indicated in written form by a comma. Under this analysis, sentences like (30b) and (31b) are not problematic for a configurational version of the binding theory. Since the names are within sentential adjuncts, they are not vc-commanded (or c-commanded) by the coindexed pronouns in the main clause, and Principle C is not violated.

- (32) a. When he gets one of his tantrums, Ben is impossible.
 b. [_S [When he_i gets one of his tantrums] [_S Ben_i is impossible]].

- (33) [_S [_S He_i’s impossible] [when Ben_i gets one of his tantrums]].

- (34) * [_S He_i [_{VP} always [_{VP} gets angry [when Sandy_i is criticized]]]]

⁸The reader is referred to Reinhart (1983), especially chapter 4, for her survey of functional approaches, which I cannot reproduce here for reasons of space.

⁹I thank an anonymous reviewer for pointing out to me this symmetry of adjunct configurations.

The *when*-clauses in (30a) and (31a), on the other hand, are analyzed as VP-adjuncts, as shown in (34). Hence, the name is vc-commanded by the coindexed subject pronoun of the main clause in violation of Principle C.

Further evidence that *when*-clauses can appear in different structural positions and thus behave differently with respect to Principle C is provided by Kazanina (2005, pp. 13-21). She argues that in the sentences in (35), the name in the *when*-clause and the pronoun in the matrix clause can be coreferential since the *when*-clause is a sentential rather than a VP-modifier. To justify her claim, Kazanina presents several arguments. First, she observes that the *when*-clauses in (35) contain a non-agentive event which is not controlled by the agent of the main clause and often causes surprise or even shock for that agent. Changing the content of the *when*-clause so that it expresses an agentive event results in decreasing acceptability of coreference between the two subjects, as shown in (36).

- (35) a. He_i had been staring at the control panel for over an hour when Jack_i received a message from his commander.
 b. He_i was threatening to leave when Jack_i noticed that the computer had died.
 c. He_i was about to place a few bets when Mike_i was advised that the cops were in the bar.
- (36) a. ?? He_i had been staring at the control panel for over an hour when Jack_i gave an order to his soldier.
 b. * He_i was threatening to leave when Jack_i turned on his computer.
 c. * He_i was about to place a few bets when Mike_i started singing a song.

Secondly, Kazanina claims that *when*-clauses have different statuses depending on the various interpretations of the word *when*.¹⁰ These include an interpretation corresponding to the subordinator *while* and thus serving to provide the background for the main event (see (37a)), and an interpretation similar to *after*, which links the subclausal event expressing a cause to the main clause event that expresses the result of that cause (see (38a)). In both cases, *when* locates the event of the main clause inside the event of the embedded clause, and a *when*-question about the main event (see (37b)/(38b)) is felicitously answered by the sentence. As the (c)-sentences in (37) and (38) show, coreference between the pronoun in the main clause and the name within the *when*-clause is impossible in these cases.

- (37) a. Mary was talking on the phone when John was cooking dinner.
 b. When was Mary talking on the phone?
 c. He_{*i}/_{*k} was talking on the phone when John_i was cooking dinner for Mark_k.

¹⁰Kazanina (2005) refers to Moens and Steedman (1988) and Harris and Bates (2002), who noted that *when* is ambiguous and that its different interpretations depend on the different kinds of events that it links.

- (38) a. Kate broke the glass when John kicked the door.
 b. When did Kate break the glass?
 c. * He_i broke the glass when John_i kicked the door.

In the sentences in (35), in which coreference is available, *when* functions as a coordinator with an interpretation like “and/but suddenly at that moment”. The event in the main clause serves as a setting for the event expressed by the subordinate clause. According to Kazanina, these sentences are infelicitous as an answer to a corresponding *when*-question about the main event, even when coreference is not at issue, as the following question-answer pairs show:

- (39) a. When had he been staring at the control panel?
 b. Larry had been staring at the control panel for over an hour when Jack received a message from his commander.
- (40) a. When was he threatening to leave?
 b. Mark was threatening to leave when Jack noticed that the computer had died.
- (41) a. When was he about to place a few bets?
 b. Samuel was about to place a few bets when Mike was advised that the cops were in the bar.

The contrast in behavior between the sentences in (35) and (37)-(38) is unnatural if *when* has the same status in all of these sentences. However, Kazanina (2005) claims that it can be straightforwardly explained under the assumption that there are two different kinds of *when*. One functions as a sentential modifier that adjoins to IP (or S), and the other is a VP-modifier that adjoins to VP. So, when a question is asked about temporal properties of the VP that expects a VP-modifier as an answer, it follows naturally that the sentences in (35) and (39)-(41) are infelicitous as answers since the *when*-clauses here are sentential adjuncts. In addition, the differences in binding behavior are correctly predicted. In (37) and (38), *when* functions as a subordinator and adjoins to VP. Hence, coreference between the main clause subject and the name within the adjunct is ruled out by Principle C. In (35), *when* is similar to a coordinator and therefore reasonably adjoined to S, where it escapes a Principle C violation.

Kazanina (2005) and Kazanina et al. (2007) also provide psycholinguistic evidence that Principle C is syntactic in nature by investigating backwards anaphora in language development and in sentence processing. Based on a comprehension task with 3-6-year-old Russian speaking children, Kazanina (2005) shows that structural constraints on coreference, in particular Principle C, are respected by children already at the age of three. The Russian-specific discourse constraint on backwards anaphora, on the other hand, becomes operative in the child’s grammar only at the age of 5-6. In real-time processing, the findings from several online self-paced reading studies on English and Russian reveal that backwards anaphora dependencies are processed with a grammatically constrained active search mechanism. This

means that when the parser encounters a cataphoric pronoun, it actively searches for an antecedent in the following material. Importantly, during this search, it does not consider positions that are excluded by Principle C. Additionally, results from offline acceptability rating experiments show that judgments of coreference are degraded when a pronoun c-commands its antecedent (Kazanina, 2005; Kazanina et al., 2007).

Summarizing the discussion, the data that have been claimed to undermine the structural account of Principle C stop being problematic once they are carefully analyzed and a proper syntactic structure is provided. Results from psycholinguistic investigations show that structural constraints on coreference exert an influence at the earliest stage of language development and real-time processing. I therefore conclude that there is no strong evidence against the syntactic nature of Principle C.

7 Conclusion

In this paper, I have argued, following Hukari and Levine (1995), that structural configurations must be taken into account in order to capture the intricate binding-theoretic interactions between adjunct-internal and main clause elements, which are not predicted by P&S-94's binding theory. To this end, Hukari and Levine introduced the configurational relation of vc-command and reformulated Principle C so that it prohibits coindexation under both relations, o-command and vc-command. Phenomena such as the (anti)reconstruction and VP topicalization effects fall out from this revision. I have developed Hukari and Levine's approach further and proposed a refinement of the definition of vc-command. My proposal has four benefits: First, my revised definition of vc-command does not involve a modality, and secondly, it motivates the superior role of the subject in binding. Thirdly, I have proposed crucially different interactions of the relations of o-command and vc-command with fillers (including extraposed constituents). Fourthly, I have provided new data that strongly support the proposed revision of the HPSG binding theory. Finally, I have shown that, once they are correctly analyzed, the data that have been provided against a syntactic account of Principle C can be explained straightforwardly by the configurational binding theory proposed here.

References

- Bickerton, Derek. 1975. Some Assertions about Presuppositions about Pronominalization. In Robin E. Grossman, L. James San and Timothy J. Vance (eds.), *Papers from the Parasession on Functionalism*. Chicago Linguistic Society, April 17, 1975, pages 24–35, Chicago: CLS.
- Bolinger, Dwight. 1979. Pronouns in Discourse. In Talmy Givón (ed.), *Discourse and Syntax*, volume 12 of *Syntax and Semantics*, pages 289–309, New York: Academic Press.

- Bouma, Gosse, Malouf, Robert and Sag, Ivan A. 2001. Satisfying Constraints on Extraction and Adjunction. *Natural Language and Linguistic Theory* 19(1), 1–65.
- Bresnan, Joan. 2001. *Lexical-Functional Syntax*. Malden, Mass. and Oxford, UK: Blackwell Publishers.
- Chomsky, Noam. 1981. *Lectures on Government and Binding*. Dordrecht: Foris Publications.
- Crysmann, Berthold. To appear. On the Locality of Complement Clause and Relative Clause Extraposition. In Gert Webelhuth, Manfred Sailer and Heike Walker (eds.), *Righthward Movement in a Comparative Perspective*, Amsterdam: John Benjamins.
- Culicover, Peter W. and Rochemont, Michael S. 1990. Extraposition and the Complement Principle. *Linguistic Inquiry* 21(1), 23–47.
- Fox, Danny and Nissenbaum, Jon. 1999. Extraposition and Scope: A Case for Overt QR. In Sonya Bird, Andrew Carnie, Jason D. Haugen and Peter Norquest (eds.), *Proceedings of the Eighteenth West Coast Conference on Formal Linguistics*, pages 132–144, Somerville, MA: Cascadilla Press.
- Fox, Danny and Nissenbaum, Jon. 2000. Extraposition and Covert Movement, unpublished manuscript.
- Guéron, Jacqueline and May, Robert. 1984. Extraposition and Logical Form. *Linguistic Inquiry* 15(1), 1–31.
- Harris, Catherine L. and Bates, Elizabeth A. 2002. Clausal Backgrounding and Pronominal Reference: A Functionalist Approach to C-command. *Language and Cognitive Processes* 17(3), 237–269.
- Huang, C.-T. James. 1993. Reconstruction and the Structure of VP: Some Theoretical Consequences. *Linguistic Inquiry* 24(1), 103–138.
- Hukari, Thomas E. and Levine, Robert D. 1995. On SLASH Termination and Valence-based Binding Theory. Paper presented at the LSA meeting, January 1995, New Orleans.
- Hukari, Thomas E. and Levine, Robert D. 1996. Phrase Structure Grammar: The Next Generation. *Journal of Linguistics* 32(2), 465–496.
- Kazanina, Nina. 2005. *The Acquisition and Processing of Backwards Anaphora*. Ph. D.thesis, University of Maryland, College Park.
- Kazanina, Nina, Lau, Ellen F., Lieberman, Moti, Yoshida, Masaya and Phillips, Colin. 2007. The Effect of Syntactic Constraints on the Processing of Backwards Anaphora. *Journal of Memory and Language* 56, 384–409.
- Keenan, Edward L. and Comrie, Bernard. 1977. Noun Phrase Accessibility and Universal Grammar. *Linguistic Inquiry* 8(1), 63–99.
- Keller, Frank. 1994. Extraposition in HPSG. Verbmobil Report 30, IBM Germany, Institute for Logic and Linguistics, Heidelberg.
- Kiss, Tibor. 2005. Semantic Constraints on Relative Clause Extraposition. *Natural Language and Linguistic Theory* 23(2), 281–334.
- Kuno, Susumu. 1975. Three Perspectives in the Functional Approach to Syntax. In Robin E. Grossman, L. James San and Timothy J. Vance (eds.), *Papers from*

- the Parasession on Functionalism. Chicago Linguistic Society, April 17, 1975, pages 276–336, Chicago: CLS.*
- Lebeaux, David. 1988. *Language Acquisition and the Form of the Grammar*. Ph.D.thesis, University of Massachusetts, Amherst.
- McCray, Alexa T. 1980. The Semantics of Backward Anaphora. *Cahiers Linguistique d'Ottawa* 9, 329–343.
- Moens, Marc and Steedman, Mark. 1988. Temporal Ontology and Temporal Reference. *Computational Linguistics* 14(2), 15–28.
- Müller, Stefan. 1999. *Deutsche Syntax deklarativ. Head-Driven Phrase Structure Grammar für das Deutsche*. Linguistische Arbeiten, No. 394, Tübingen: Max Niemeyer Verlag.
- Pollard, Carl J. and Sag, Ivan A. 1987. *Information-based Syntax and Semantics, Vol. 1*. CSLI Lecture Notes, No. 13, Stanford University: CSLI Publications, distributed by University of Chicago Press.
- Pollard, Carl J. and Sag, Ivan A. 1992. Anaphors in English and the Scope of Binding Theory. *Linguistic Inquiry* 23, 261–303.
- Pollard, Carl J. and Sag, Ivan A. 1994. *Head-Driven Phrase Structure Grammar*. Chicago: University of Chicago Press.
- Reinhart, Tanya. 1976. *The Syntactic Domain of Anaphora*. Ph.D.thesis, MIT, Cambridge, Mass.
- Reinhart, Tanya. 1981. Definite NP Anaphora and C-Command Domains. *Linguistic Inquiry* 12(4), 605–635.
- Reinhart, Tanya. 1983. *Anaphora and Semantic Interpretation*. London: Croom Helm.
- Sag, Ivan A. 2005. Adverb Extraction and Coordination: A Reply to Levine. In Stefan Müller (ed.), *The Proceedings of the 12th International Conference on Head-Driven Phrase Structure Grammar, Department of Informatics, University of Lisbon*, pages 322–342, Stanford: CSLI Publications.
- van Noord, Gertjan and Bouma, Gosse. 1994. The Scope of Adjuncts and the Processing of Lexical Rules. In *Proceedings of COLING 94*, pages 250–256, Kyoto.
- van Riemsdijk, Henk and Williams, Edwin. 1981. NP-Structure. *The Linguistic Review* 1(2), 171–217.