

Sentential specifiers in the Korean clause structure

Incheol Choi 

Kyungpook National University

Proceedings of the 19th International Conference on
Head-Driven Phrase Structure Grammar

Chungnam National University Daejeon

Stefan Müller (Editor)

2012

Stanford, CA: CSLI Publications

pages 75–85

Choi, Incheol. 2012. Sentential specifiers in the Korean clause structure. In Stefan Müller (ed.), *Proceedings of the 19th International Conference on Head-Driven Phrase Structure Grammar, Chungnam National University Daejeon*, 75–85. Stanford, CA: CSLI Publications. DOI: 10.21248/hpsg.2012.5. 

Abstract

The Korean double nominative construction exhibits various properties distinguished not only from ordinary subject-object clauses but also from nominative complement constructions. Particularly, the second NP, not the initial NP, triggers the honorific agreement with the verb. I argue that the first NP of the construction is identified as a sentential specifier which exists in addition to the subject (cf. Major subject in Yoon 2004). The sentential specifier can be justified as the characteristic of the topic-prominent language in the sense of Li and Thompson (1976). Specifically I claim that any elements that satisfy the *aboutness* condition can be the sentential specifier. Finally, I show that HPSG's valence value and an optional lexical rule provides an elegant treatment of the construction; SPR list in a sentence level can be utilized for the sentential specifier (cf. Kim et al. 2007).

1. Introduction

The Korean double nominative construction exhibits various properties distinguished from the typical clauses. For example, the first nominative-marked NPs in (1) do not necessarily have a selectional relation with the verbs in the clauses. Instead, the second nominative-marked NPs are the semantic subject of the verb.

- (1) a. Ken-i ape.nim-i kyoswu-i-si-ta
Ken-NOM father(HON)-NOM Prof.-COPU-HON-DECL
'As for Ken, his father is a professor.'
- b. LA-ka hankwuk. salam-i manhi sa-n-ta
LA-NOM Korean.people-NOM many live-PRES-DECL
'As for LA, many Korean people live there.'

This double nominative construction is distinguished not only from ordinary subject-object clauses but also from nominative complement constructions in (2) in that the first NP in (2) triggers the honorific agreement with the verb in contrast to those in (1).

- (2) John-i ape.nim-i silh-(*usi)-ta
John-NOM father.HON-NOM hate>(*HON)-DECL
'John hates his father.'

Previous approaches to the Korean double nominative construction can be categorized into two types. The first type is the focus analyses proposed by Kim (2000), Schütze (2001), and Kim et al. (2007). In this type of approaches, the first NP of the construction is considered the syntactic realization of the focus information. The second type is the movement analyses proposed by Kang (1986) and J-Y Yoon (1989). In this type of analyses, the first NP is formed through a movement starting from the possessive NP position of the subject.

In this paper, I suggest that the previously suggested analyses cannot correctly catch the characteristics of the construction. Instead, I argue that the first NP of the construction is identified as a sentential specifier which exists in addition to the subject (cf. Major subject in Yoon 2004; Small subject in Shibatani 1999; Narrow/Thematic subject in Doron and Heycock 1999). The sentential specifier can be justified as the characteristic of the topic-prominent language in the sense of Li and Thompson (1976). Specifically I claim that any elements that satisfy the *aboutness* condition can be the sentential specifier. That is, if an element is characterized by the subsequent phrase, it satisfies the *aboutness* condition (Kang 1988; O. Grady 1991, Hong 1997, Yoon 2004).

2. Review of the Previous Analyses

2.1 Movement Analyses

Kang (1986), Yoon (1989) and many other scholars suggest that the first NP of the double nominative construction is generated in the possessor position of the subject and moved to the first NP position as illustrated in (3).

- (3) a. Ken_i-i [S [NP t_i ape.nim-i] kyoswu-i-si-ta]
 Ken-NOM father(HON)-NOM Prof.-COPU-HON-DECL
 ‘As for Ken, his father is a professor.’

However, as shown in (1b) the first NP is not necessarily identified with the possessive NP of the subject. Furthermore, not all the possessive NPs of the subjects can move into the first NP position (Kim 2000).

- (4) Yangccok-**i*/-uy pulsin-i i sathay-lul
 Both.sides-NOM/-GEN distrust-NOM this situation-ACC
 cholayhayss-ta
 caused-DEC
 ‘The distrust between both sides caused this situation.’

2.2 Focus Analyses

Kim (2000), Schütze (2001), Kim et al. (2007) and many other scholars suggest that the first NP of the construction is the syntactic realization of the focus information which is independent of syntactic relation such as subject and object. According to Kim (2000), the sentence in (5) is ungrammatical because only the first NP of the construction has the focus function, hence able to be *wh*-questioned.

- (5) *Ken-i nwu-ka puca-i-si-ni?
Ken-NOM who-NOM rich.man-COP-HON-Q
'Who of Ken's is rich?'

However, even assuming that the first NP is a focus phrase, it does not explain why the subject NP cannot be *wh*-questioned. This is because Korean allows multiple foci in a clause. Further, there are some cases in which the first NP should also be identified as a subject as in (6).

- (6) Kim_i-i [t_i cha-ka kocangnass-ko]
Kim-NOM car-NOM broke-CONJ
[t_i ton-to up-ta]
money-either have.no-DECL
'Kim's car broke down, and she has no money.'

In focus analyses, the NP *Kim* will be identified as the focus owing to the unsaturated element in the first conjunct. However, it should also be identified as the subject owing to the unsaturated element of the second conjunct. The unsaturated NP of the second conjunct is a subject while the NP *ton-i* is analyzed as a nominative-marked complement. Therefore, the initial NP in (6) cannot meet the different requirements that are derived from the two conjuncts. This dilemma will not be avoided as long as the first NP is considered as the focus distinguished from typical grammatical relations.

3. Sentential Specifiers

In this paper, I propose that the first NP of the double nominative construction is identified with a sentential specifier. As suggested by Yoon (2004), the sentential specifier is based-generated in a position preceding a subject and takes the following part of the sentence as its sentential

complement (cf. Park 1981). As widely accepted, Korean has both the properties of the subject oriented language and the topic-prominent language. Therefore, it is not completely startling to assume that Korean has the sentential specifier in addition to the subject.

Many scholars of Korean linguistics have mentioned that the double nominative construction has something to do with the semantic *aboutness* condition. That is, the sentential specifier is significantly characterized by the subsequently following parts of the sentence. I also suggest that the aboutness condition is the licensing condition of the sentential specifier. There is ample evidence that supports the proposed sentential specifier analysis. First, as reported by Wechsler and Lee (1995) and Choi (2008), any element that satisfies the *aboutness* condition can undergo the subject to object raising.

- (7) a. na-nun Ken-ul_i [t_i ape.nim-i kyoswu-lako]
 I-TOP Ken-ACC father(HON)-NOM Prof.-COMP
 sayngkakhayssta
 believed
 ‘I thought Ken’s father is a profeseor.’
- b. na-nun LA-lul_i [t_i hankwuk.salam-i manhi
 I-TOP LA-ACC Korean people-NOM a lot
 santa-ko] sayngkakhayssta
 live-COMP believed
 ‘I thought LA is where many Koreans live.’
- c. na-nun ecye-lul_i [t_i ol eylum cwung nalssi-ka
 I-TOP yesterday-ACC this summer during weather-NOM
 kacang tewessta-ko] syangkakhan-ta
 most be.hot-COMP think-DEC
 ‘I thought that yesterday was the hottest day in this summer.’

The raised elements in (7) are identical to the sentential speicifier, but not the subjects. This coincidence follows our assumption that what is raised in the Korean raising construction is the sentential specifier. That is, an element that does not satisfy the *aboutness* condition cannot undergo subject-to-object raising, as shown in (8).

- (8) ? na-nun Ken-ul_i [t_i pap-ul mekessta-ko] sayngkahassta
 I-TOP Ken-ACC meal-ACC ate.-COMP believed
 ‘I thought that Ken ate his meal.’

A raised question from this analysis may be how we should deal with the cases in which the raised element is a subject as in (9).

- (9) Na-nun kim-ul [t cip-ey ton-i up-ta-ko]
 I-TOP Kim-ACC home-at money-NOM have.no-CONJ
 syangkakhayssta
 thought
 'I believed Kim to have no money.'

The raised element in (9) is the subject as I mentioned regarding the sentence in (6). However, it also satisfies the *aboutness* condition for the subject NP. Nothing blocks a semantic subject from being realized as a sentential specifier as long as the following VP satisfies the *aboutness* condition for the NP. Therefore, the coordination dilemma shown in (6) will not take place in my approach. This is because what is raised in (9) is the sentential specifier although it is semantically identified as a subject. Therefore, the possibility of the coordination as in (6) itself becomes the supporting evidence of my approach.

Further, the ungrammaticality of the sentence (5) can be well explained in this approach. Specifically, when the subject becomes *wh*-questioned the resultant clause cannot characterize the sentential specifier. However, when the *wh*-questioned element does not significantly undermine the *aboutness* condition, the acceptability of the sentence remarkably improves as shown in (10)

- (10) Ken-i ape.nim-i muess-ha-si-ni?
 Ken-NOM father(HON)-NOM what-do-HON-Q?
 'What does Ken's father do?'

The Korean reflexive binding also supports my approach. As illustrated by the sentence in (11), the sentential specifier can be referred to by the Korean reflexive *caki*(self).

- (11) Ken_i-i apeci-ka caki_i-uy saup-ul taisin hanta
 Ken-NOM father-NOM self-GEN business-ACC substitute did
 'Ken's father runs the business for Ken.'

In Korean, *caki* is known as a subject oriented reflexive. Therefore, (11) shows that the sentential specifier should be considered as an ARG-ST list member that stands comparison with the subject.

4. HPSG Formalization

In this section, I will show how the proposed ideas can be embraced by the sign-based HPSG formalism. I have shown that the first NP of the Korean double nominative construction is identified as the sentential specifier which satisfies the *aboutness* condition. HPSG's valence value and an optional lexical rule provide an elegant treatment of the construction. Specifically, SPR list in a sentence level can be utilized for the sentential specifier.

(12) SPR lexical rule I (optional)

$$\left[\begin{array}{l} \text{HEAD } verb \\ \text{DEPS } \langle \dots, \boxed{1}NPi, \dots \rangle \\ \text{INDEX } s \\ \text{RELS } \langle \dots, \left[\begin{array}{ll} \text{PRED } aboutness \\ \text{SIT } s \\ \text{ARG } i \end{array} \right] \dots \rangle \end{array} \right] \rightarrow \left[\begin{array}{l} verb \\ \text{VAL } [\text{SPR } \langle \boxed{1}NP[nom]i \rangle] \end{array} \right]$$

(13) SPR lexical rule II (optional)¹

$$\left[\begin{array}{l} \text{VAL } \left[\begin{array}{l} \text{SPR } \langle \boxed{1} \rangle \\ \text{SUBJ } \langle \text{NP } [\text{SPR } \langle \boxed{1}NPi \rangle] \rangle \end{array} \right] \\ \text{INDEX } s \\ \text{RELS } \langle \dots, \left[\begin{array}{ll} \text{PRED } aboutness \\ \text{SIT } s \\ \text{ARG } i \end{array} \right], \dots \rangle \end{array} \right]$$

¹ On this point, the treatment is similar to Kim et al. (2007) in that the unsaturated specifier of the subject appears in the SPR list of the matrix verb. However, the SPR list here does not host subjects.

(14) a. kyoswu-i-si-ta

$$\left[\begin{array}{l} \text{VAL} \left[\text{SPR} \langle \boxed{1} \rangle \right. \\ \left. \text{SUBJ} \langle \text{NP} [\text{SPR} \langle \boxed{1} \text{NP}i \rangle] \rangle \right] \\ \text{INDEX} \quad s \\ \text{RELS} \langle \dots, \left[\begin{array}{ll} \text{PRED} & \textit{aboutness} \\ \text{SIT} & s \\ \text{ARG} & i \end{array} \right], \dots \rangle \end{array} \right]$$

b. sa-n-ta

$$\left[\begin{array}{l} \text{HEAD} \quad \boxed{2} \\ \text{VAL} [\text{SPR} \langle \boxed{1} \rangle] \\ \text{INDEX} \quad s \\ \text{DEPS} \langle \boxed{1} \text{NP} \left[\begin{array}{l} \text{MOD} \quad \boxed{2} \\ \text{CONT} \quad \textit{locative - rel} \end{array} \right], \dots \rangle \\ \text{RELS} \langle \dots, \left[\begin{array}{ll} \text{PRED} & \textit{aboutness} \\ \text{SIT} & s \\ \text{ARG} & i \end{array} \right], \dots \rangle \end{array} \right]$$

The element that appears in the sentential specifier position is a subject, the specifier of a subject or adjuncts. Following Bouma et al. (2001), I assume that a subject and adjuncts appear in a DEPS list. The rule in (12) declares that any DEPS list member which satisfies the *aboutness* condition can appear in the SPR list. However, the rule in (12) does not apply to specifiers of subjects. To ensure that the specifier of a subject becomes the sentential specifier, we need an additional rule as in (13). Now, with the rules in (12) and (13), all the elements that can satisfy the *aboutness* condition become the member of the SPR list. For example, the rules will change the verb lexemes in (1) to those in (14).

Now, the final step to accommodate this idea in the HPSG framework will be to posit the additional Head-specifier construction rule as in (15).

(15) Head-Specifier Rule

$$\left[\begin{array}{l} \textit{phrase} \\ \text{SPR} \langle \quad \rangle \end{array} \right] \rightarrow \boxed{1} \text{NP} \left[\begin{array}{l} \text{VAL} \left[\begin{array}{l} \text{SPR} \langle \boxed{1} \rangle \\ \text{SUBJ} \langle \quad \rangle \\ \text{COMPS} \langle \quad \rangle \end{array} \right] \end{array} \right]$$

The rule in (15) allows the phrase whose SUBJ and COMPS lists are already saturated to combine with the sentential specifier. This process is illustrated by the tree diagrams in (16) and (17), which illustrate the syntactic structures of the sentences in (1).

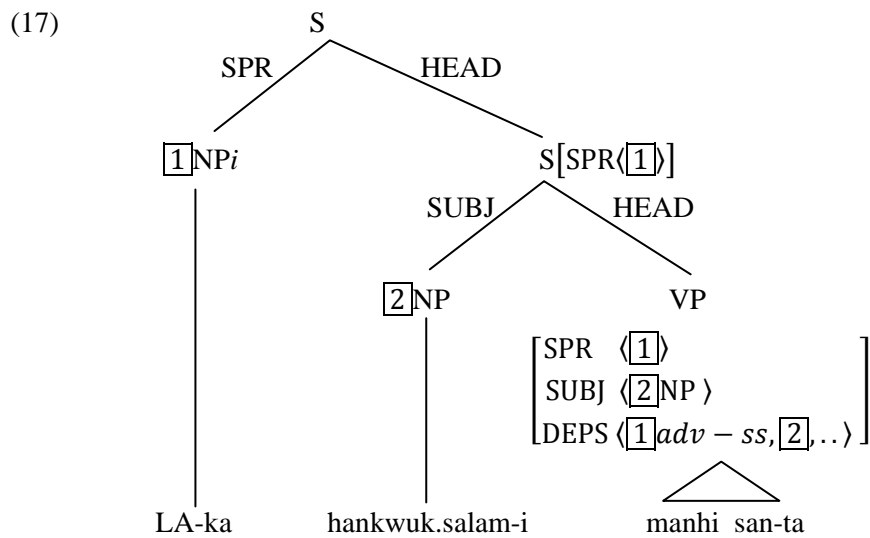
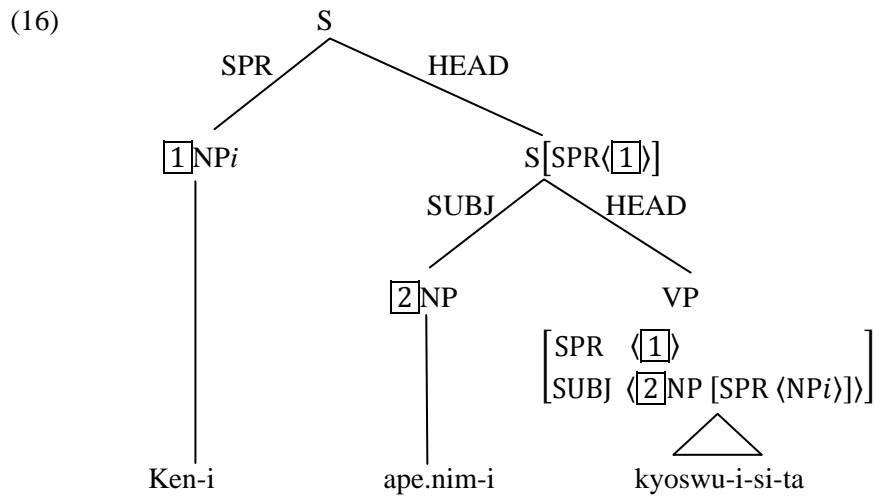

5. Conclusion

Under the analysis proposed in this paper, the Korean double nominative construction is interpreted as a characteristic of the topic oriented language. Therefore, the nominative marked first NP of the construction is not an adjunct derived from certain syntactic operation. Instead, in this paper, it is

considered a grammatical relation that exists in addition to the subject, i.e. sentential specifier. Specifically, I suggested that the proposed SPR list licenses the sentential specifier relation. To a certain extent, this proposal embraces the traditional ideas such as Major Subject and sentential predicates in that the SPR list hosts the NPs that are predicated by sentential predicate (Park 1981, Yoon 2004). The HPSG sign-based syntactic treatment neatly deals with this idea by assuming the SPR list is utilized in the verbal syntactic domain.

References

- Bouma, G, Malouf, R, and Sag, I. 2001. Satisfying Constraints on Extrraction and Adjunction. *Natural Language & Linguistic Theory* 19:1-65.
- Choi, I.-C. 2008. The Partial Parallelism between Double Nominative Construction and ECM Construction in Korea. *Studies in Modern Grammar* 53: 75-101.
- Doron, E., and C. Haycock. 1999. "Filling and Licensing Multiple Specifiers", In *Specifiers: Minimalist Approaches*, D. Adger, S. Pintzuk, B. Plunkett, and G. Tsoulas (eds), 69-89. Oxford: Oxford University Press.
- Hong, K.-S. 1997. Eynge-wa kwuke-uy insang kwumwun pikyo pwunsek (Subject-to-object. raising constructions in English and Korean), *Language Research* 33, 409-434.
- Kang, B.-M. 1988. Functional Inheritance, anaphora and semantic interpretation. Doctoral Dissertation. Brown University.
- Kang, Y.-S. 1986. Korean Syntax and Universal Grammar. Doctoral Dissertation. Harvard University.
- Kim, J.-B, Sells, P, and Yang, J-H. 2007. Parsing Two Types of Multiple Nominative Constructions: A Constructional Approach. *Language and Information*, 11.1 25-37
- Kim, J.-B. 2000. A Constraint-Based and Head-driven Approach to Multiple Nominative Constructions. Flickinger, D. and A. Kathol (eds.) *Proceedings of the HPSG-2000 Conference*. Stanford: CSLI Publications.
- Li, C. and S. Thompson. 1976. Subject and Topic: A New Typology of Language. Li, C. (ed.) *Subject and Topic*, 457-489. New York: Academic Press.
- O'Graddy, W. D. 1991. *Categories and Case: The Sentence Structure of Korean*. Amsterdam: John Benjamins Publishing.
- Park, B.-S. 1981. Double Subject Constructions Revisited. *Linguistics in the Morning Calm*, 645-658. Seoul: Hanshin.

- Schütze, C. T. 2001. On Korean "Case Stacking": The Varied Functions of the Particles *Ka* and *lul*. *The Linguistic Review* 18:193-232.
- Shibatani, M. 1999. Dative Subject Constructions twenty-two years later. In *Elements of Grammar*, L. Haegeman (ed), 281-337. Dordrecht: Kluwer Academic Press.
- Wechsler, S and Lee, Y.-S. 1995. Korean ECM: Semantic and Pragmatic Factors. Paper presented at The 69th Annual Meeting of the Linguistic Society of America, New Orleans.
- Yoon, J.-Y. 1989. On the Multiple 'ka' and 'lul' Constructions in Korean. Kuno, S. et al. (eds.) *Harvard Studies in Korean Linguistics*, 383-394. Seoul: Hanshin.
- Yoon, J. 2004. Non-nominative (Major) Subjects in Korean. Bhaskararao, P. and K. V. Subbarao (eds.) *Non-nominative Subjects*. Berlin: Mouton de Gruyter.