

The direct evidential *-te* in Korean: Its interaction with person and experiencer predicates

Juwon Lee 

University of Texas at Austin

Proceedings of the 19th International Conference on
Head-Driven Phrase Structure Grammar

Chungnam National University Daejeon

Stefan Müller (Editor)

2012

Stanford, CA: CSLI Publications

pages 251–271

Lee, Juwon. 2012. The direct evidential *-te* in Korean: Its interaction with person and experiencer predicates. In Stefan Müller (ed.), *Proceedings of the 19th International Conference on Head-Driven Phrase Structure Grammar, Chungnam National University Daejeon*, 251–271. Stanford, CA: CSLI Publications. DOI: 10.21248/hpsg.2012.15. 

Abstract

This paper discusses the complex relations among the direct evidential *-te*, *person*, and experiencer predicates in Korean. The questions of the paper are: (i) how the three components are related with each other in the evidential sentences, and (ii) how the interactions of the three components can be formally analyzed to correctly license only the well-formed evidential sentences. I show that in direct evidential construction with a non-private predicate (e.g. *pwutulep-* ‘soft’), the asserter/epistemic authority (i.e. the speaker *na* ‘I’ in declarative or the addressee *ne* ‘you’ in question) must be the experiencer of the predicate, but there is no such constraint in direct evidential construction with a private predicate (e.g. *aphu-* ‘sick’). I also show that the direct evidential construction with a non-private predicate is an instance of self-ascription. Then I propose an analysis of the experiencer predicates and associated lexical rules in the Minimal Recursion Semantics (MRS) (Copestake, *et al.*, 2005) of Head-driven Phrase Structure Grammar (HPSG) (Pollard and Sag, 1994; Sag, *et al.*, 2003).

1 Introduction

The direct evidential *-te* in Korean has been much studied (see e.g. Sohn, 1994; Cinque, 1999; Chung, 2006; Lim, 2011; Lee, 2011, and also see Japanese evidentials in Kuno, 1973; Kuroda, 1973; Tenny, 2006; McCready and Ogata, 2007; and evidentials in various languages in Aikhenvald, 2004, among others). For example, in the following contrast between the non-evidential sentence and the direct evidential sentence in (1), only the latter has the direct evidential implication that the assertion of the proposition is based on relevant direct evidence.

- (1) Mary-ka ku sakwa-lul **mek-ess-ta/ mek-te-la**.
Mary-Nom the apple-Acc eat-Past-Dec/ eat-Te-Dec¹
‘Mary ate the apple.’/
‘Mary ate the apple.’ Implication: the speaker has relevant direct evidence (e.g. the speaker *saw* the scene) for the asserted proposition that Mary ate the apple.

In addition to actions denoted by verbs, states of adjectives (e.g. experiencer predicates) can also be asserted based on relevant direct evidence, as

· I would like to thank Stephen Wechsler for his valuable comments on this paper. The helpful comments of the anonymous reviewers and the audiences at the HPSG 2012 Conference are also gratefully acknowledged. Any remaining errors are mine.

¹ Abbreviations: Acc = Accusative, Comp = Complementizer, Cop = Copula, Dec = Declarative, Nom = Nominative, Past = Past, Pres = Present, Prog = Progressive, Que = Question, Rel = Relativizer, Te = *te*, Top = Topicalization.

illustrated in (2) and (3) below. However, as shown in (3b), it is not the case that the direct evidential constructions are always grammatical in Korean, which is less discussed in the literature (the empirical basis of the acceptability of the examples in (2) and (3) is discussed more in the next section).

- (2) a. **na/ ne/ ku-nun** simcang-i **aphu-ta**.
 I/ you/ he-Top heart-Nom sick-Dec
 ‘My/ Your/ His heart is sick.’
- b. **na/ ne/ ku-nun** simcang-i **aphu-te-la**.
 I/ you/ he-Top heart-Nom sick-Te-Dec
 ‘My/ Your/ His heart was sick (based on relevant direct evidence).’
- (3) a. **na/ ne/ ku-nun** i peykay-ka **pwutulep-ta**.
 I/ you/ he-Top this pillow-Nom soft-Dec
 ‘This pillow felt soft to me/ you/ him.’
- b. **na/ *ne/ *ku-nun** i peykay-ka **pwutulep-te-la**.
 I/ you/ he-Top this pillow-Nom soft-Te-Dec
 ‘This pillow felt soft to me/ *you/ *him (based on relevant direct evidence).’

In (2) and (3), the contrasts show the complex interactions between the direct evidential *-te*, *person*, and experiencer predicates: from the minimal pairs in (3b), the type of the personal pronoun subject is a factor of the grammaticality, from the contrasts between (2b) and (3b), the type of the experiencer predicate is also important, and finally, the minimal pairs between (3a) and (3b) show that the existence of the direct evidential *-te* is also involved in the grammaticality (or acceptability) of the constructions.

The two main questions which I aim to answer are: (i) how exactly the three components are related with each other in the evidential sentences, and (ii) how the interactions of the three components can be formally analyzed to correctly license only the well-formed evidential sentences.

Regarding these two issues, I show that in Korean direct evidential construction with a non-private predicate (e.g. *pwutulep-* ‘soft’), the asserter (i.e. the speaker *na* ‘I’ in declarative or the addressee *ne* ‘you’ in question) must be the experiencer (i.e. the subject) of the predicate, but there is no such constraint in direct evidential construction with a private predicate (e.g. *aphu-* ‘sick’). I also argue that the direct evidential construction with a non-private predicate is an instance of self-ascription (see e.g. Wechsler, 2010, 2012 for self-ascription). Then, based on the grammatical properties of the constructions, I propose an analysis of the experiencer predicates and related inflectional lexical rules in the framework of the Minimal Recursion Semantics (MRS) (Copestake, *et al.*, 2005) of Head-driven Phrase Structure Grammar (HPSG) (Pollard and Sag, 1994; Sag, *et al.*, 2003).

2 Grammaticality vs. awkwardness of experiencer predicates

In this section, I look into the grammaticality and acceptability of experiencer predicates, and argue that some Korean experiencer predicate constructions which were previously considered ungrammatical are actually not ungrammatical, but awkward due to some pragmatic factors.

Direct experiencer predicates denote some feelings, sensations, or experiences of subjects.² In the Japanese declarative sentences (4a) (from Tenny, 2006: 247), the predicate of direct experience (i.e. *samui* ‘cold’) restricts its subject to the first-person pronoun (i.e. *watashi* ‘I’). However, when the same predicate of direct experience is used in a question, as in (4b), the predicate restricts its subject to the second-person pronoun (i.e. *anata* ‘you’) (Kuno, 1973 cited in Tenny, 2006: 247).

- (4) a. **Watashi/** *anata/ *kare wa samui desu.
 I/ you/ he Top cold Cop
 ‘I am cold.’ / *‘You are cold.’ / *‘He is cold.’
- b. *Watashi/ **anata/** *kare wa samui desu-ka?
 I/ you/ he Top cold Cop-Que
 *‘Am I cold?’ / ‘Are you cold?’ / *‘Is he cold?’

According to Tenny (2006: 248), the starred sentences in (4) are clearly *ungrammatical* while some corresponding English sentences may appear somewhat *odd*. The ungrammaticality or oddness of the starred sentences appears to be based on the fact that it is generally hard for a person to get access to another person’s sensations or feelings. For example, in the question (4b) with the third-person subject, the addressee is expected to have access to another person’s sensation.

In the footnote 3 of Tenny (2006), the author says, “Chungmin Lee informs me that these facts in Japanese are largely parallel to the facts in Korean.” However, in the footnote 4 of Tenny (2006), the author also says, “Some speakers have informed me that among younger Japanese, sentences like *Kare wa samui desu* are not as bad; the phenomenon may be disappearing in the language.”

Similarly, the Korean sentences corresponding to (4a) with the second- or third-person subject seem to be *not as bad*, even though they sound somewhat *awkward* (like English) without a plausible context. According to No (1989), the non-occurrence of third-person with an emotion verb in Korean is

² There are different names for experiencer predicates: for instance, sensation verbs (e.g. Kuroda, 1973; Talmy 1985), emotion verbs (e.g. No, 1989) or psychological verbs (e.g. Lee, 1976; Yang, 1994). They appear to be equivalent to each other. In this paper, I use the term, experiencer predicates.

subject to register variation: i.e. in a certain register, the combination is possible. We can find empirical data supporting it; the subject of a direct experiencer predicate can be second-person, as in (5b), or third-person, as in (5c), although the first-person subject in (5a) sounds most natural (data from the web).

- (5) a. **na-nun** nemwu **sulphu-ta**.³
 I-Top very sad-Dec
 ‘I am very sad.’
- b. twi tol-a po-nun **ne-nun pwulanha-ta**.⁴
 back turn-Comp see-Rel you-Top anxious-Dec
 ‘You, turning and looking back, are anxious.’
- c. nwun-ey teph-i-myen **ku-nun chwup-ta**.⁵
 snow-in cover-Pass-if he-Top cold-Dec
 ‘If covered in snow, he is cold.’

Thus there seems to be less person restriction related with the experiencer predicates in Korean. If a context (e.g. which is associated with evidence about the state of the experiencer) is explicitly given, as in (5b,c), the experiencer predicate sentences sound better.

Also, in a Korean question, the first- or third-person pronoun can be the subject of an experiencer predicate (unlike the Japanese questions in (4b)), as shown in (6a,c), respectively, even though the second-person subject in (6b) is most natural (data from the web).

- (6) a. **na-nun chwuwun-ka**?
 I-Top cold-Que
 son-ul po-ni kwayen ttelli-ko iss-ess-ta.⁶
 hand-Acc see-when indeed shiver-Comp Prog-Past-Dec
 ‘Am I cold? When I saw my hand, it was shivering indeed.’
- b. **ne-nun oylowun-ka**?⁷
 you-Top lonely-Que
 ‘Are you lonely?’
- c. **ku-nun oylowun-ka**?⁸
 he-Top lonely-Que
 ‘Is he lonely?’

³ <http://blog.daum.net/yea-an/16877065>

⁴ <http://blog.eduhope.net/edustory/?d=2010-03-19>

⁵ <http://softdrink.egloos.com/196996>

⁶ http://www.munpia.com/bbs/view.php?id=cn_173&no=201

⁷ <http://cafe.daum.net/tnehdka/DZHE/1248?docid=qTVADZHE124820100927101713>

⁸ <http://serrana.egloos.com/m/3596217>

The empirical data in (5) and (6) suggest that the restriction on the personal pronoun subject in declarative and interrogative with experiencer predicate is a matter of *the degree of awkwardness*, rather than a matter of *grammaticality* (at least in Korean).

Another piece of evidence in favor of *the degree of awkwardness* comes from the fact that the experiencer predicate declarative sentences with the second-person subject sound more awkward than the comparable sentences with the third-person subject. In both cases, the speaker has the difficulty of getting access to another person's sensation. However, in terms of *epistemic authority* (the person who has primary authority for the truth or knowledge of the proposition expressed, see Wechsler, 2012 for the concept), the two sentences are different: i.e. in the former, the addressee is the epistemic authority for her sensation, but in the latter, the addressee is not the epistemic authority for a third person's sensation. In other words, it can be weird for the speaker to inform the addressee of the addressee's sensation since generally the addressee knows about her sensation much better than the speaker (i.e. the addressee is the epistemic authority here). However, this kind of awkwardness is not found in the experiencer predicate declarative sentences with the third-person subject.

If the speaker has a clear reason to tell the addressee's sensation to the addressee, then the relevant sentence should sound less awkward (or more natural). This is shown in the following sentences which are augmented with a plausible context:

- (7) a. **ne-nun** i peykay-ka **pwutulep**-ciman
 you-Top this pillow-Nom soft-but
 aninchek-ha-ko iss-ta.
 pretend.not-do-Comp Prog-Dec
 'This pillow feels soft to you,
 but you are pretending that it does not feel soft.'
- b. **ne-nun** ku koki-ka **masiss**-ciman
 you-Top the meat-Acc tasty-but
 aninchek-ha-ko iss-ta.
 pretend.not-do-Comp Prog-Dec
 'The meat tastes good to you,
 but you are pretending that it does not taste good.'

In (7), while the speaker may be considered to be aggressive, the sentences sound better than the corresponding sentences without such a context.

Also, in the experiencer predicate interrogatives (6) above, the sentence with the first-person subject sounds more odd than the sentences with the third-person subjects. Both cases have the addressee's problem of getting access to another person's feeling, but the former has another pragmatic pro-

blem: i.e. it is normally not natural for a person not to know her own feelings and so ask others about them. However, it is not that people always have access to their own sensations perfectly. So if the speaker is not sure about her sensations, and wants to verify them by asking the addressee, then the interrogative sentences with the first-person subject become better:

- (8) a. **na-nun chwuwun-ka?**
 I-Top cold-Que?
 ne-ka poki-ey-to kulay?
 you-Top seeing-at-also so.que
 ‘Am I cold? Do you also see that I am cold?’
- b. **na-nun oylowun-ka?**
 I-Top lonely-Que?
 ne-ka poki-ey-to kulay?
 you-Top seeing-at-also so.que
 ‘Am I lonely? Do you also see that I am lonely?’

Now let us consider direct evidential constructions headed by an experiencer predicate. In a certain type of direct evidential constructions, even the context cannot save the evidential sentences with the second- or third-person subject. Although in (9a), the context (i.e. the medical examination results) makes the direct evidential constructions (with *aphu-* ‘sick’) more natural, the context in (9b) does not have such an effect: the direct evidential constructions (with *masiss-* ‘tasty’) still sound very bad.

- (9) a. kemsakyeikwa-lul po-nikka
 examination.result-Acc see-since
ne/ ku-nun simcang-i manhi aphu-te-la.
 you/ he-Top heart-Nom very sick-Te-Dec
 ‘Your/ His heart was very sick
 according to the medical examination results.’
- b. *mek-nun mosup-ul po-nikka
 eat-Rel scene-Acc see-since
ne/ ku-nun ku koki-ka cengmal masiss-te-la.
 you/ he-Top the meat-Nom really tasty-Te-Dec
 *‘The meat tastes really good to you/ him
 according to my observation.’

If the subjects in (9b) are replaced with the first-person subject, the sentence is well-formed even without a context. Thus in (9b) the three components (i.e. personal pronoun subject, experiencer predicate, and the direct evidential *-te*) are responsible for the ungrammaticality. Each component is discussed in the three sections that follow.

3 Personal pronouns in Korean

In this section, I present the basic paradigm of Korean personal pronouns and their properties as a type of indexicals. In the following table, Korean personal pronouns are presented:

Table 1: Personal Pronouns in Korean

Person	Singular	Plural
First	<i>na</i> ‘I’	<i>wuli(-tul)</i> ‘we’
Second	<i>ne</i> ‘you.SG’	<i>nehuy(-tul)</i> ‘you.PL’
Third	<i>ku</i> ‘he’, <i>kunye</i> ‘she’	<i>ku-tul</i> ‘they’, <i>kunye-tul</i> ‘they.FEM’

Korean has some honorific or humble forms of the personal pronouns, but they are not included in the table; only basic personal pronouns are given in the table. For the first- or second-person plural pronoun, the plural marker *-tul* is optional since they already have the distinguished forms from the singular counterparts (i.e. *na* vs. *wuli*, *ne* vs. *nehuy*). However, in case of the third-person plural pronouns, the plural marker *-tul* is required. In this paper, I focus on the singular personal pronouns (i.e. *na* ‘I’, *ne* ‘you’, *ku* ‘he’, *kunye* ‘she’).

The main point of the person indexicals is that the first- and second-person pronouns (i.e. speech act participant indexicals) are speaker-dependent: their interpretations vary depending on who the speaker or addressee is (see e.g. Kaplan, 1977; Wechsler, 2010). For instance, in Korean, *na* ‘I’ always refers to the speaker (i.e. whoever says *na* ‘I’ is the speaker), and *ne* ‘you’ always refers to the addressee. However, the referents of the third-person pronouns normally exclude speaker and addressee (see e.g. Wechsler, 2010).

In interrogatives, the first- and second-person pronouns are also anchored to the speaker and addressee, respectively. This is a crucial difference from evidentials. In declarative evidential constructions, the evidential is anchored to the speaker (i.e. the speaker has evidence), but in interrogative evidential constructions, it is anchored to the addressee (i.e. the addressee is expected to have evidence) (see more on the direct evidential *-te* in Section 5 below).

4 Two types of experiencer predicates

In this section, I argue that the experiencer predicates in Korean can be broadly classified into two types based on their semantic and syntactic properties (cf. English experiencer predicates in Pesetsky, 1987): (i) private predicate (e.g. *aphu-* ‘sick’, *oylop-* ‘lonely’, *chup-* ‘cold’, *tep-* ‘hot’ representing the mental state of the subject) and (ii) non-private predicate (e.g. *pwutulep-* ‘soft’, *kkachilkkachilha-* ‘rough’, *masiss-* ‘tasty’, *ttaktakha-* ‘hard’ denoting the state of a stimulus that the subject experiences).

First, experiencer predicates can be identified by a test: if and only if a predicate can be combined with the verb *ha* ‘do’, the predicate is an emotion verb (i.e. experiencer predicate) (No, 1989):

- (10) a. Tom-i **oylo-we** **hay-ss-ta.**
 Tom-Nom lonely-Comp do-Past-Dec
 ‘Tom was feeling lonely.’
- b. Tom-i ku koki-lul **masiss-e** **hay-ss-ta.**
 Tom-Nom the meat-Acc tasty-Comp do-Past-Dec
 ‘The meat was tasty to Tom.’
- c. *Tom-i hanul-ul **phalay** **hay-ss-ta.**
 Tom-Nom sky-Acc blue.Comp do-Past-Dec
- d. *Tom-i ku koki-lul **mek-e** **hay-ss-ta.**
 Tom-Nom the meat-Acc eat-Comp do-Past-Dec

In (10), the combination of an experiencer predicate and the verb *ha* ‘do’ denotes an activity, not a state anymore. One piece of evidence is that the present tense morpheme *-n* can be attached to the verb *ha* (e.g. *Tom-i oylo-we ha-n-ta* ‘Tom feels/is feeling lonely.’) (see more e.g. in Park, 1974; Yang, 1994).

Equipped with the identification of experiencer predicates, I show several differences of the two types (i.e. private- and non-private) of experiencer predicates. In (11a), the sentence has only one interpretation (i.e. the speaker is the experiencer), but in (11b), the sentence is ambiguous: the speaker is either the experiencer or the stimulus which brings about the sensation to an unexpressed experiencer. Note that Korean is a pro-drop language.

- (11) a. na-nun **oylop-ta.**
 I-Top lonely-Dec
 ‘I am lonely.’
- b. na-nun **masiss-ta.**
 I-Top tasty-Dec
 ‘Something is tasty to me.’
 ‘I am tasty e.g. to a monster.’
- c. sokoki-nun **masiss-ta.**
 beef-Top tasty-Dec
 ‘Beef is tasty.’

In (11c), if a specific experiencer is not inferred from the context, *masiss-* ‘tasty’ is used as a predicative adjective denoting the generic meaning.

If a second nominative phrase (i.e. a stimulus) appears in a sentence headed by *masiss-* ‘tasty’, the subject is interpreted as experiencer, but not as

stimulus, as in (12b). However, in (12a) with *oylop-* ‘lonely’, the subject remains the experiencer.

- (12) a. *na-nun kaul nalssi-ka nemwu oylop-ta.*
I-Top autumn weather-Nom very lonely-Dec
‘I am very lonely due to the autumn weather.’
- b. *na-nun ku koki-ka nemwu masiss-ta.*
I-Top the meat-Nom very tasty-Dec
‘The meat is very tasty to me’

In (13), the pronoun *na* ‘I’ comes with a relative clause. In (13a), the speaker is the experiencer, but in (13b), the speaker is not experiencer, but stimulus.

- (13) a. *oylo-wun na*
lonely-Rel I
‘I, who am lonely’
- b. *masiss-nun na*
tasty-Rel I
‘I, who am tasty e.g. to a monster’

In short, *masiss-* ‘tasty’ is ambiguous between experiencer predicate and predicative adjective, but *oylop-* ‘lonely’ is simply an experiencer predicate. A stimulus complement (i.e. the second nominative NP) is required for the *masiss-* type experiencer predicates.

5 The direct evidential *-te*

In this section, I present the two main properties of the direct evidential *-te*: indexicality and presupposition.

First, evidentials have a property of indexicality (i.e. speaker-dependent): *the speaker* has evidence for an asserted proposition (see e.g. Garrett, 2001; McCready and Ogata, 2007; Lim, 2010). In other words, whoever says a declarative evidential sentence has relevant evidence for the proposition denoted by a predicate. However, evidential is shifted in interrogatives (unlike *you* and *I*). The evidential *-te* in declaratives is anchored to the speaker, but in interrogatives, it is anchored to the addressee (see e.g. Lim, 2010). That is, whoever is being asked an evidential question is expected to have relevant evidence for the proposition expressed by a predicate. So, we can say that in declaratives, the speaker is the utterer and asserter (or epistemic authority), but in interrogatives, the speaker is the utterer and the addressee is induced to assert (i.e. epistemic authority). In short, evidentials are always anchored to the asserter/epistemic authority (cf. Lim, 2010).

Second, I adopt the idea that evidentials are like presupposition (e.g. Matthewson, *et al.*, 2007; Lim, 2010): the evidential implication of *-te* cannot be negated or questioned.⁹ The following shows the negative counterparts of the examples in (2b) and (3b):

- (14) a. *na/ne/ku-nun simcang-i an aphu-te-la.*
 I/you/he-Top heart-Nom Neg sick-Te-Dec
 ‘My/ Your/ His heart was not sick
 (based on relevant direct evidence).’
- b. *na/*ne/*ku-nun i peykay-ka an pwutulep-te-la.*
 I/you/he-Top this pillow-Nom Neg soft-Te-Dec
 ‘This pillow did not feel soft to me/ *you/ *him
 (based on relevant direct evidence).’

In (14), the direct evidential implications are not negated, but are still included in the meanings of the constructions.

In the interrogatives (15), the implications of the direct evidential *-te* are not questioned, either.

- (15) a. *ne-nun chup-te-nya?*
 you-Top cold-te-Que
 ‘Were you cold?’ Implication: the addressee is expected to answer based on relevant direct evidence.
- b. *ne-nun i uyca-ka ttakttakha-te-nya?*
 you-Top this chair-Nom hard-Te-Que
 ‘Did this chair feel hard to you?’ Implication: the addressee is expected to answer based on relevant direct evidence.

These two key facts indicate that the meaning (i.e. the implication) conveyed by the direct evidential *-te* is a presupposition.

6 The direct evidential *-te*, *person* and *experiencer* predicates

Based on the properties of the three components, we can see that in direct evidential construction with a private predicate (e.g. *aphu-* ‘sick’), the asserter does not need to be the experiencer (i.e. subject), but in direct evidential sentence with a non-private predicate (e.g. *pwutulep-* ‘soft’), the asserter must be the experiencer. These facts can be explained by considering the flow of information in an utterance:

⁹ I do not here discuss the status of presupposition in terms of semantic value.

(16) a. Information flow in declarative direct evidential construction with private predicate:

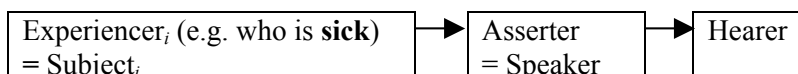

b. Information flow in declarative direct evidential construction with non-private predicate:

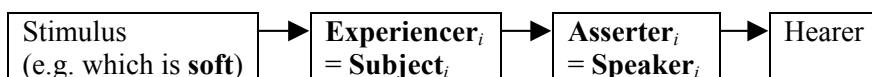

In (16a), the asserter can directly observe the psychological state of the experiencer, which is denoted by a private predicate: i.e. the asserter can have access to direct evidence on the state of the experiencer. So whatever *person* the subject is, the construction satisfies the requirement of the direct evidential *-te* (i.e. the asserter's direct observation). But in (16b), the asserter cannot directly observe the property of the stimulus, which is described by a non-private predicate since it is the experiencer who directly observes (i.e. experiences) it. Thus in order to have access to direct evidence on the property of the stimulus, the asserter must be co-indexed with the experiencer. That is, only under the co-indexation, the construction can satisfy the requirement of the direct evidential *-te* (i.e. the asserter's direct observation).

7 Predictions in interrogatives

From the general constraint in (16) (i.e. the asserter's direct observation of the state or property denoted by an experiencer predicate), we can predict that in interrogative direct evidential construction with a private predicate (e.g. *oylop*- 'lonely'), any personal pronoun can be the subject, but in interrogative direct evidential construction with a non-private predicate (e.g. *pwutulep*- 'soft'), only the second-person pronoun *ne* 'you' (i.e. the asserter/epistemic authority in questions) can be the subject. This is confirmed as below:

(17) a. **na/ ne/ ku-nun** manhi **oylop-te-nya?**

I/you/he-Top very lonely-te-Que

'Was I/ Were you/ Was he very lonely?' Implication: the addressee is expected to answer based on relevant direct evidence.

b. ***na/ ne/ *ku-nun** i peykay-ka manhi **pwutulep-te-nya?**

I/you/he-Top this pillow-Nom very soft-Te-Que

'Did this pillow feel very soft to *me/ you/ *him?' Implication: the addressee is expected to answer based on relevant direct evidence.

In (17a), when the subject is *na* 'I', it sounds somewhat awkward. However, we can find situations in which it sounds more natural: e.g. a patient may ask

a psychiatrist about her states.

Then, the information flow of the interrogative direct evidential constructions can be represented with the following diagrams:

(18) a. Information flow in interrogative direct evidential construction with private predicate:

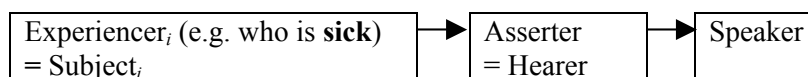

b. Information flow in interrogative direct evidential construction with non-private predicate:

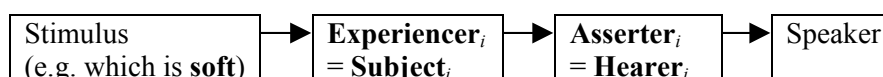

In (18a), the asserter/hearer can have access to direct evidence for the proposition denoted by a private predicate. So, this interrogative construction satisfies the requirement of the direct evidential *-te* (i.e. the asserter’s direct observation). In (18b), however, the experiencer has access to direct evidence for the proposition about the stimulus; so the asserter/hearer (i.e. epistemic authority in interrogatives) can have access to direct evidence for the state of the stimulus only through its co-indexation with the experiencer/subject. Then the interrogative construction can satisfy the requirement of the direct evidential *-te* (i.e. the asserter’s direct observation).

8 Self-ascription

This section shows that direct evidential constructions with a non-private predicate belong to self-ascription.

In a self-ascription (or *reference de se*), “someone ascribes a property, she ascribes the property to herself: she believes that she has the property” (Wechsler, 2012: 11). For instance, if John says *I drank too much*, he self-ascribes the property ‘drank too much’: i.e. John has a *de se* belief (see more about *de se* belief in Lewis, 1979). However, if a friend shows John a photo in which someone in the photo is wearing a lampshade on his head, John does not know it is himself in the picture, and John says, *he drank too much*, then John does not self-ascribe the property of drinking too much: i.e. John has a *de re* belief (a belief about a real thing, but not about identity) (Wechsler, 2012: 12).

Based on the self-ascription, Wechsler (2012) accounts for the distribution of conjunct verb form in Kathmandu Newar.¹⁰ In the following declaratives (from Hargreaves 2005, cited in Wechsler, 2012: 3), the conjunct form (CJ) appears only on the verb whose subject is first-person:

¹⁰ See alternative accounts compared with self-ascription in Wechsler (2012).

- (19) a. *jī:* a:pwa twan-ā.
 1.ERG much drink-PST.CJ
 ‘I drank a lot/too much.’
- b. *chā* a:pwa twan-a.
 2.ERG much drink-PST.DJ
 ‘You drank a lot/too much.’
- c. *wā:* a:pwa twan-a.
 3.ERG much drink-PST.DJ
 ‘S/he drank a lot/too much.’

In (19a), the subject (i.e. the speaker) self-ascribes the VP-denoted property (i.e. drinking too much). The conjunct form is specialized for encoding of self-ascription.

In interrogatives, however, the addressee is being asked whether the addressee would self-ascribe the VP-denoted property ‘drink too much’. So the conjunct form appears on the verb whose subject is second-person (Wechsler, 2012):

- (20) a. *jī:* a:pwa twan-alā?
 1.ERG much drink-PST.DJ Q
 ‘Did I drank a lot/too much?’
- b. *chā* a:pwa twan-ā lā?
 2.ERG much drink-PST.CJ Q
 ‘Did you drank a lot/too much?’
- c. *wā:* a:pwa twan-alā?
 3.ERG much drink-PST.DJ Q
 ‘Did s/he drank a lot/too much?’

The Japanese experiencer predicates in (4) can also be accounted for with the self-ascription: the Japanese experiencer predicates are specified for self-ascription, or at least favor it (Wechsler, 2012). So self-ascription can be encoded with different grammatical categories: a morphological category is used for Kathmandu Newar, but the lexical class of experiencer predicates is used for Japanese.

In much the same way, the combination of the direct evidential *-te* (i.e. morphological level) and a non-private predicate (i.e. lexical level) is an instance of self-ascription. The direct evidential *-te* requires that the asserter have direct evidence on an asserted proposition, but the proposition denoted by a non-private predicate is basically about a stimulus (unlike proposition of private predicate), which is not next to the asserter in terms of the information flow, as illustrated in (16b) and (18b). So in order for the asserter to get

access to direct evidence on an asserted proposition about the stimulus, the asserter must be the subject/experiencer (i.e. the speaker *na* ‘I’ in declarative or the addressee *ne* ‘you’ in interrogative). This combination of the properties of *-te* and a non-private predicate has the effect of inducing the meaning of a self-ascription.

In the following table, the relations between experiencer predicates, the direct evidential *-te* and self-ascription are represented:

Table 2: Grammatical encoding of self-ascription in Korean

Grammatical encoding	Self-ascription
Private predicate	favor self-ascription (specified for or favor it in Japanese)
Non-private predicate	favor self-ascription
Direct evidential with private predicate	favor self-ascription
Direct evidential with non-private predicate	specified for self-ascription

In Table 2, the direct evidential construction with a non-private predicate has the meaning of self-ascription in Korean. Other constructions only favor self-ascription since the first-person subject in declaratives or the second-person subject in interrogatives is favored due to some pragmatic factors presented in Section 2.

9 An analysis of the direct evidential constructions

Here I propose an analysis of the Korean experiencer predicates and four inflectional lexical rules that systematically generate evidential experiencer predicates which can be used in declaratives or interrogatives.

In the following type hierarchy, the type of experiencer predicate (i.e. *exp-prd*) is claimed to have two subtypes (i.e. *private* and *non-private*):

(21) Local type hierarchy of experiencer predicate:

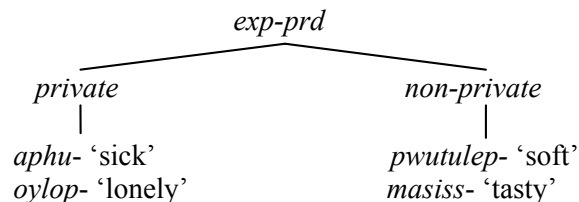

Then relevant constraints are declared on the types in the hierarchy, as repre-

sented in (22).

(22) a. Constraints on *exp-prd*:

$$\left[\begin{array}{l} \textit{exp-prd} \\ \text{SUBJ} < \text{NP}[\textit{nom}] > \end{array} \right]$$

b. Constraints on *private*:¹¹

$$\left[\begin{array}{l} \textit{private} \\ \text{SUBJ} < \text{NP}[\underline{1}] > \\ \\ \text{CONT} \left[\text{RELS} < \left[\begin{array}{l} \text{LBL h1} \\ \text{ARG0 e1} \\ \text{ARG1} [\underline{1}] \end{array} \right] > \right] \end{array} \right]$$

c. Constraints on *non-private*:

$$\left[\begin{array}{l} \textit{non-private} \\ \text{SUBJ} < \text{NP} > \\ \text{COMPS} < \text{NP}[\underline{1}][\textit{nom}] > \\ \\ \text{CONT} \left[\text{RELS} < \left[\begin{array}{l} \text{LBL h1} \\ \text{ARG0 e1} \\ \text{ARG1} [\underline{1}] \end{array} \right] > \right] \end{array} \right]$$

Due to (22a), all the experiencer predicates have a subject. In (22b), the subject of a private predicate is co-indexed with the ARG1 of its semantic relation. In (22c), however, the complement nominative NP (i.e. the stimulus which has the property denoted by the predicate) is co-indexed with the ARG1 of the semantic relation.

The following lexemes have phonological and relational specifications in their feature structures:

(23) a. constraints on *aphu-* ‘sick’:

$$\left[\begin{array}{l} \text{PHON} < \textit{aphu-} > \\ \text{CONT} \left[\text{RELS} < [\textit{_sick_rel}] > \right] \end{array} \right]$$

b. constraints on *pwutulep-* ‘soft’:

$$\left[\begin{array}{l} \text{PHON} < \textit{pwutulep-} > \\ \text{CONT} \left[\text{RELS} < [\textit{_soft_rel}] > \right] \end{array} \right]$$

The following two inflectional lexical rules are posited to generate private evidential declarative words and private evidential interrogative words (i.e. from the private predicate lexemes to the words). Since no dependent morpheme is inserted in between the direct evidential *-te* and the declarative marker (*-la*) or interrogative marker (*-nya*), the inflectional lexical rules combine a private predicate lexeme with the combination, *-tela* or *-tenya*:

¹¹ Exact paths are omitted for the sake of concise representations of feature structures.

(24) a. Private Evidential Declarative Lexical Rule:

$$\left[\begin{array}{l}
 \begin{array}{l}
 i\text{-rule} \\
 \text{INPUT} < \boxed{1}, [\textit{private}] >
 \end{array} \\
 \\
 \begin{array}{l}
 \text{CONT} \left[\begin{array}{l}
 \text{HOOK} < \left[\begin{array}{l} \text{LTOP } h2 \\ \text{INDEX } e1 \end{array} \right] > \\
 \text{RELS} < \left[\begin{array}{l} \text{LBL } h1 \\ \text{ARG0 } e1 \\ \text{ARG1 } i \ v \ j \ v \ k \end{array} \right], \left[\begin{array}{l} \text{_prpstn_m_rel} \\ \text{LBL } h2 \\ \text{MARG1 } h1 \end{array} \right] >
 \end{array} \right] \\
 \\
 \text{CNXT} \left[\begin{array}{l}
 \text{BCKG} < \left[\begin{array}{l} \text{_assert_rel} \\ \text{LBL } h3 \\ \text{ARG0 } e2 \\ \text{ARG1 } i \\ \text{ARG2 } j \\ \text{ARG3 } h4 \\ \text{ARG4 } h1 \end{array} \right], \left[\begin{array}{l} \text{_direct_} \\ \text{evidence_rel} \\ \text{LBL } h4 \\ \text{ARG0 } e3 \\ \text{ARG1 } i \\ \text{ARG2 } h1 \end{array} \right] > \\
 \text{C-INDS} \left[\begin{array}{l} \text{C-SPEAKER } i \\ \text{C-ADDRESSEE } j \end{array} \right]
 \end{array} \right]
 \end{array} \\
 \\
 \begin{array}{l}
 \text{OUTPUT} < F_{\textit{tela}} (\boxed{1}),
 \end{array}
 \end{array} \right]$$

b. Private Evidential Interrogative Lexical Rule:

$$\left[\begin{array}{l}
 \begin{array}{l}
 i\text{-rule} \\
 \text{INPUT} < \boxed{1}, [\textit{private}] >
 \end{array} \\
 \\
 \begin{array}{l}
 \text{CONT} \left[\begin{array}{l}
 \text{HOOK} < \left[\begin{array}{l} \text{LTOP } h2 \\ \text{INDEX } e1 \end{array} \right] > \\
 \text{RELS} < \left[\begin{array}{l} \text{LBL } h1 \\ \text{ARG0 } e1 \\ \text{ARG1 } i \ v \ j \ v \ k \end{array} \right], \left[\begin{array}{l} \text{_int_m_rel} \\ \text{LBL } h2 \\ \text{MARG1 } h1 \end{array} \right] >
 \end{array} \right] \\
 \\
 \text{CNXT} \left[\begin{array}{l}
 \text{BCKG} < \left[\begin{array}{l} \text{_assert_rel} \\ \text{LBL } h3 \\ \text{ARG0 } e2 \\ \text{ARG1 } j \\ \text{ARG2 } i \\ \text{ARG3 } h4 \\ \text{ARG4 } h1 \end{array} \right], \left[\begin{array}{l} \text{_direct_} \\ \text{evidence_rel} \\ \text{LBL } h4 \\ \text{ARG0 } e3 \\ \text{ARG1 } j \\ \text{ARG2 } h1 \end{array} \right] > \\
 \text{C-INDS} \left[\begin{array}{l} \text{C-SPEAKER } i \\ \text{C-ADDRESSEE } j \end{array} \right]
 \end{array} \right]
 \end{array} \\
 \\
 \begin{array}{l}
 \text{OUTPUT} < F_{\textit{tenya}} (\boxed{1}),
 \end{array}
 \end{array} \right]$$

In BCKG (Background) of CNXT (Context) of the output, [_assert_rel] and [_direct_evidnece_rel] are included. In the declarative rule, [_prpstn_m_rel] is added to the RELS, and C(ontext)-SPEAKER (indexed with *i*) is co-indexed with the asserter, but in the interrogative rule, [_int_m_rel] is added to the RELS, and C-ADDRESSEE (indexed with *j*) is co-indexed with the asserter. Since direct evidence is obtained by observations (e.g. seeing, hearing, touching), the [_direct_evidence_rel] is interpreted as an event (marked

with e3) whose agent is co-indexed with the asserter.

Now the following words can be licensed from the private predicate lexemes through the lexical rules:

(25) a. *aphu-tela*:

PHON < <i>aphu-tela</i> > SUBJ < NP _[i v j v k] >	CONT <table style="border-collapse: collapse; margin-left: 10px;"> <tr> <td style="border-right: 1px solid black; padding-right: 5px;">HOOK < [LTOP h2 INDEX e1] ></td> <td style="padding-left: 5px;"></td> </tr> <tr> <td style="border-right: 1px solid black; padding-right: 5px;">RELS < [sick_rel LBL h1 ARG0 e1 ARG1 [i]] , [prpstn_m_rel LBL h2 MARG1 h1] ></td> <td style="padding-left: 5px;"></td> </tr> </table>	HOOK < [LTOP h2 INDEX e1] >		RELS < [sick_rel LBL h1 ARG0 e1 ARG1 [i]] , [prpstn_m_rel LBL h2 MARG1 h1] >	
HOOK < [LTOP h2 INDEX e1] >					
RELS < [sick_rel LBL h1 ARG0 e1 ARG1 [i]] , [prpstn_m_rel LBL h2 MARG1 h1] >					
CNXT <table style="border-collapse: collapse; margin-left: 10px;"> <tr> <td style="border-right: 1px solid black; padding-right: 5px;">BCKG < [assert_rel LBL h3 ARG0 e2 ARG1 i ARG2 j ARG3 h4 ARG4 h1] , [direct_evidence_rel LBL h4 ARG0 e3 ARG1 i ARG2 h1] ></td> <td style="padding-left: 5px;"></td> </tr> </table>	BCKG < [assert_rel LBL h3 ARG0 e2 ARG1 i ARG2 j ARG3 h4 ARG4 h1] , [direct_evidence_rel LBL h4 ARG0 e3 ARG1 i ARG2 h1] >		C-INDS [C-SPEAKER i C-ADDRESSEE j]		
BCKG < [assert_rel LBL h3 ARG0 e2 ARG1 i ARG2 j ARG3 h4 ARG4 h1] , [direct_evidence_rel LBL h4 ARG0 e3 ARG1 i ARG2 h1] >					

b. *aphu-tenya*:

PHON < <i>aphu-tenya</i> > SUBJ < NP _[i v j v k] >	CONT <table style="border-collapse: collapse; margin-left: 10px;"> <tr> <td style="border-right: 1px solid black; padding-right: 5px;">HOOK < [LTOP h2 INDEX e1] ></td> <td style="padding-left: 5px;"></td> </tr> <tr> <td style="border-right: 1px solid black; padding-right: 5px;">RELS < [sick_rel LBL h1 ARG0 e1 ARG1 [i]] , [int_m_rel LBL h2 MARG1 h1] ></td> <td style="padding-left: 5px;"></td> </tr> </table>	HOOK < [LTOP h2 INDEX e1] >		RELS < [sick_rel LBL h1 ARG0 e1 ARG1 [i]] , [int_m_rel LBL h2 MARG1 h1] >	
HOOK < [LTOP h2 INDEX e1] >					
RELS < [sick_rel LBL h1 ARG0 e1 ARG1 [i]] , [int_m_rel LBL h2 MARG1 h1] >					
CNXT <table style="border-collapse: collapse; margin-left: 10px;"> <tr> <td style="border-right: 1px solid black; padding-right: 5px;">BCKG < [assert_rel LBL h3 ARG0 e2 ARG1 j ARG2 i ARG3 h4 ARG4 h1] , [direct_evidence_rel LBL h4 ARG0 e3 ARG1 j ARG2 h1] ></td> <td style="padding-left: 5px;"></td> </tr> </table>	BCKG < [assert_rel LBL h3 ARG0 e2 ARG1 j ARG2 i ARG3 h4 ARG4 h1] , [direct_evidence_rel LBL h4 ARG0 e3 ARG1 j ARG2 h1] >		C-INDS [C-SPEAKER i C-ADDRESSEE j]		
BCKG < [assert_rel LBL h3 ARG0 e2 ARG1 j ARG2 i ARG3 h4 ARG4 h1] , [direct_evidence_rel LBL h4 ARG0 e3 ARG1 j ARG2 h1] >					

In (25), subject NP whose index is marked with [i] can be interpreted as the speaker or the addressee or someone else.

As for non-private evidential predicates, the asserter must be the experiencer (i.e. subject). This is reflected in the following two inflectional lexical rules for declaratives and interrogatives:

(26) a. Non-Private Evidential Declarative Lexical Rule:

<i>i-rule</i> INPUT < [i], [non-private] >	SUBJ < NP _i >				
OUTPUT < F _{tela} ([i]),	CONT <table style="border-collapse: collapse; margin-left: 10px;"> <tr> <td style="border-right: 1px solid black; padding-right: 5px;">HOOK < [LTOP h2 INDEX e1] ></td> <td style="padding-left: 5px;"></td> </tr> <tr> <td style="border-right: 1px solid black; padding-right: 5px;">RELS < [LBL h1 ARG0 e1 ARG1 i] , [prpstn_m_rel LBL h2 MARG1 h1] ></td> <td style="padding-left: 5px;"></td> </tr> </table>	HOOK < [LTOP h2 INDEX e1] >		RELS < [LBL h1 ARG0 e1 ARG1 i] , [prpstn_m_rel LBL h2 MARG1 h1] >	
HOOK < [LTOP h2 INDEX e1] >					
RELS < [LBL h1 ARG0 e1 ARG1 i] , [prpstn_m_rel LBL h2 MARG1 h1] >					
	CNXT <table style="border-collapse: collapse; margin-left: 10px;"> <tr> <td style="border-right: 1px solid black; padding-right: 5px;">BCKG < [assert_rel LBL h3 ARG0 e2 ARG1 i ARG2 j ARG3 h4 ARG4 h1] , [direct_evidence_rel LBL h4 ARG0 e3 ARG1 i ARG2 h1] ></td> <td style="padding-left: 5px;"></td> </tr> </table>	BCKG < [assert_rel LBL h3 ARG0 e2 ARG1 i ARG2 j ARG3 h4 ARG4 h1] , [direct_evidence_rel LBL h4 ARG0 e3 ARG1 i ARG2 h1] >			
BCKG < [assert_rel LBL h3 ARG0 e2 ARG1 i ARG2 j ARG3 h4 ARG4 h1] , [direct_evidence_rel LBL h4 ARG0 e3 ARG1 i ARG2 h1] >					
	C-INDS [C-SPEAKER i C-ADDRESSEE j]				

b. Non-Private Evidential Interrogative Lexical Rule:

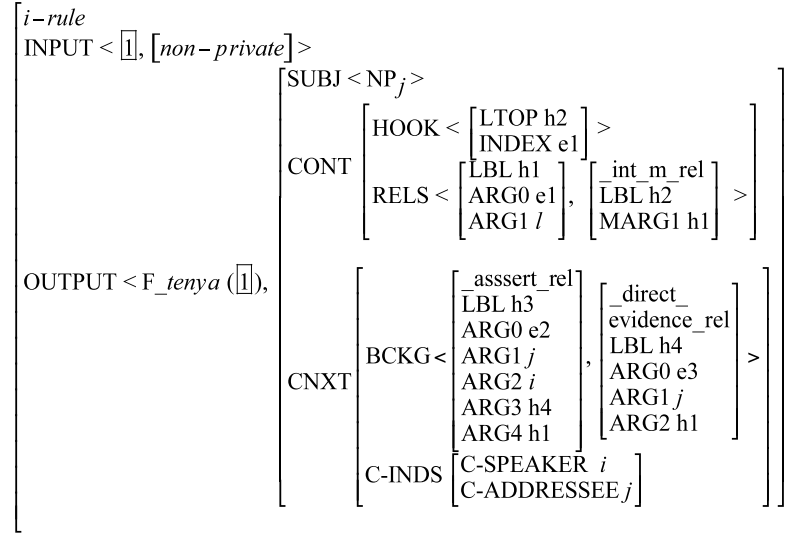

Equipped with the inflectional lexical rules in (26) and the non-private predicate lexemes, the following evidential words can be licensed:

(27) a. *pwutulep-tela*:

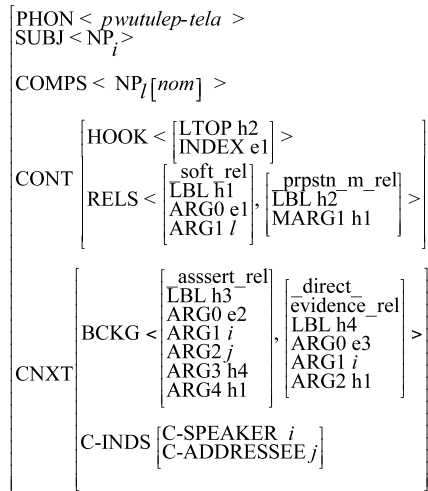

b. *pwutulep-tenya*:

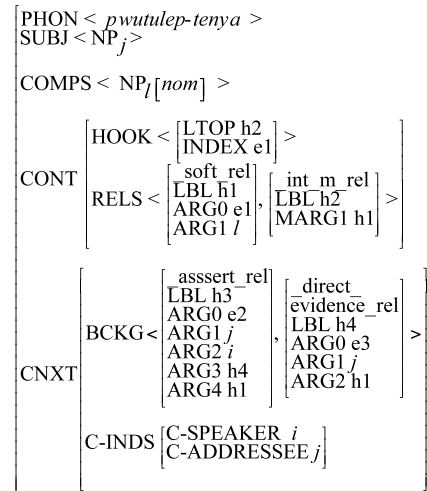

The experiencer evidential words in (25) and (27) can combine with their complement and subject by the Head-Complement Rule and Head-Subject Rule, respectively (see the phrase structure rules in Sag *et al.*, 2003; Kim, 2004).

10 Conclusion

In Korean direct evidential construction with a non-private predicate (e.g. *pwutulep-* ‘soft’), the asserter/epistemic authority (i.e. the speaker *na* ‘I’ in declarative or the addressee *ne* ‘you’ in question) must be the experiencer (i.e. subject) of the predicate. This construction is an instance of grammatically-encoded self-ascription. There is, however, no such constraint in direct evidential construction with a private predicate (e.g. *aphu-* ‘sick’). Although this construction is not specified for self-ascription, it favors self-ascription due to some pragmatic factors. An analysis of the experiencer predicates and the associated inflectional lexical rules are suggested in the HPSG framework.

The next question that can be pursued is whether the semantic, pragmatic and syntactic interactions between direct evidentiality, *person* and experiencer predicates can be applied to other languages (e.g. Japanese).

References

- Aikhenvald, Alexandra. 2004. *Evidentiality*. Oxford: Oxford University Press.
- Chung, Kyung-Sook. 2006. Korean Evidentials and Assertion. *Proceedings of the 25th West Coast Conference on Formal Linguistics*, 105-113. Somerville, MA: Cascadilla Proceedings Project.
- Cinque, Guglielmo. 1999. *Adverbs and Functional Heads: A Cross-Linguistic Perspective*. Oxford: Oxford University Press.
- Copestake, Ann, Dan Flickinger, Carl Pollard, and Ivan A. Sag. 2006. Minimal Recursion Semantics: An Introduction. *Research on Language and Computation*, 3: 281-332.
- Garrett, Edward. 2001. *Evidentiality and Assertion in Tibetan*. Doctoral Dissertation, UCLA.
- Hargreaves, David. 2005. Agency and Intentional Action in Kathmandu Newar, *Himalayan Linguistics*, 5: 1–48.
- Kaplan, David. 1977. Demonstratives: An essay on the semantics, logic, metaphysics, and epistemology of demonstratives and other indexicals. *Themes from Kaplan*, 481–566. Oxford: Oxford University Press.
- Kim, Jong-Bok. 2004. *Korean Phrase Structure Grammar*. Seoul: Hankook Munhwasa.
- Kuno, Susumu. 1973. *The Structure of the Japanese Language*. Cambridge, MA: MIT Press.
- Kuroda, Sige-Yuki. 1973. Where Epistemology, Style, and Grammar Meet: A Case Study from Japanese. In S. R. Anderson and P. Kipirsky, ed., *A Festschrift for Morris Halle*, 337-391. NY: Holt Rinehart and Willson.
- Lee, Chung-min. 1976. Cases for psychological verbs in Korean. *Ene* 1.1: 256-296.

- Lee, Jungmee. 2011. The Korean evidential *-te*: A modal analysis. In O. Bonami and P. Cabredo Hofherr, ed., *Empirical Issues in Syntax and Semantics*, 8: 287-311.
- Lewis, David. 1979. Attitudes De Dicto and De Se. *The Philosophical Review*, 88: 513–543.
- Lim, Dong Sik. 2011. *Evidentials in Interrogatives: A Case Study of Korean*. Doctoral Dissertation, University of Southern California.
- McCready, Eric and Norry Ogata. 2007. Evidentiality, modality and probability. *Linguistics and Philosophy*, 30: 147-206.
- No, Youngkyoon. 1989. Existential quantification of experiencer: Person constraint on emotion verbs and zero anaphora. *Harvard Studies in Korean Linguistics*, III: 503-516.
- Park, Byung-Soo. 1974. The Korean Verb *ha* and Verb Complementation. *Language Research*, 10.1:46-82.
- Pesetsky, David. 1987. Binding Problems with Experiencer Verbs. *Linguistic Inquiry*, 18.1: 126-140.
- Pollard, Carl and Ivan A. Sag. 1994. *Head-driven Phrase Structure Grammar*. Stanford: CSLI Publications and Chicago: The University of Chicago Press.
- Sag, Ivan A., Thomas Washow, and Emily M. Bender. 2003. *Syntactic Theory: A Formal Introduction, 2nd edition*. Stanford: CSLI Publications.
- Sohn, Ho-Min. 1994. *Korean*. London: Routledge.
- Talmy, Leonard. 1985. Lexicalization patterns. Shopen Timothy, ed., *Language Typology and Syntactic Description III*. Cambridge: Cambridge University Press.
- Tenny, Carol L. 2006. Evidentiality, Experiencers, and the Syntax of Sentences in Japanese. *Journal of East Asian Linguistics*, 15: 245-288.
- Wechsler, Stephen. 2010. What ‘you’ and ‘I’ mean to each other: Person indexicals, self-ascription, and theory of mind. *Language*, 86.2: 332-365.
- Wechsler, Stephen. 2012. Self-Ascription in Conjunction-Disjunct Systems. Manuscript, University of Texas, Austin.
- Yang, Byong-Seon. 1994. *Morphosyntactic Phenomena of Korean in Role and Reference Grammar: Psych-Verb Constructions, Inflectional Verb Morphemes, Complex Sentences, and Relative Clauses*. PhD Dissertation, State University of New York at Buffalo.