

# Reanalyzing German correlative *es*

Anke Holler 

University of Göttingen

Proceedings of the 20th International Conference on  
Head-Driven Phrase Structure Grammar

Freie Universität Berlin

Stefan Müller (Editor)

2013

Stanford, CA: CSLI Publications

pages 90–109

Holler, Anke. 2013. Reanalyzing German correlative *es*. In Stefan Müller (ed.), *Proceedings of the 20th International Conference on Head-Driven Phrase Structure Grammar, Freie Universität Berlin*, 90–109. Stanford, CA: CSLI Publications. DOI: 10.21248/hpsg.2013.5. 

## Abstract

The present article discusses several aspects of the so-called correlate-*es* construction in German. This complex clausal construction can be identified by a correlative nominal element *es* ('it') occurring in the matrix clause and a right-peripheral full clausal argument linked to *es*. The article supports the hypothesis that correlative *es* has a janus-faced nature between an expletive and a referential meaning. This is the reason why existing approaches are not sufficient to capture the properties of the discussed construction in its entirety. The first part of the article sums up the common view on correlative *es* including the empirical properties of the construction as well as a brief survey of the relevant previous approaches trying to account for correlative *es*. Based on new empirical data, the second part of the article shows that none of these accounts is able to capture all relevant facts of the correlate-*es* construction because existing approaches usually ignore that the realization of correlative *es* is verb-class dependent. Hence, a new constraint-based analysis is developed that takes both empirical observations into account, the verb-class dependence and the janus-faced nature.

## 1 Introduction

Several Germanic languages use correlatives to mark subordination. German is considered to be a prime example of a language realizing correlative constructions to embed finite argument clauses. The present article discusses complex clausal constructions in German that can be identified by a so-called correlative nominal element *es* ('it') and a right-peripheral full clausal argument that is linked to *es*. On an intuitive level *es* functions as an antecedent of the linked argument clause in these constructions. Although correlative *es* is a well-established phenomenon of German grammar, there is no theoretical account that captures the empirical facts comprehensively. In particular, the homonymy of *es* between an expletive and a referential realization form often remains unnoticed. In this article, the janus-faced nature of correlative *es* is empirically substantiated. On the basis of the reported empirical observations the article develops a new constraint-based analysis.

The article is organized as follows: After describing the phenomenon in section 2 and summing up the results of previous studies dealing with correlative *es* in section 3, empirical data that has not yet been captured in existing proposals are given in section 4. Taking into account the new data basis, section 5 then develops and outlines the aforementioned new constraint-based analysis. To conclude, the results of the paper are presented in section 6.

---

<sup>†</sup>I thank Katrin Axel for valuable discussions on the topic and the audience of the HSPG 2013 conference in Berlin for helpful comments. I am also indebted to Christine Göb for thoroughly proof-reading the manuscript and useful assistance in conducting the corpus studies. All remaining errors are of course mine.

## 2 The Phenomenon

The correlate-*es* construction is characterized by a correlative element, *es* ('it'), which occurs in the matrix clause in subject or object position and is case-marked by the matrix predicate. This correlative *es* relates in some way to a finite *dass* ('that')-marked clause serialized to its right in the syntactic surface structure.<sup>1</sup> A typical example of the correlate-*es* construction is given in (1). Most of the standard approaches assume that the *dass*-clause is located in an extraposed position since it follows the matrix clause's finite verb if the finite verb is linearized sentence-finally. Semantically, the *dass*-clause contributes to the representation the proposition that matches the selectional restrictions of the matrix predicate.

- (1) Hotzenplotz bedauert es, dass er außer Räuberei nichts gelernt hat.  
*Hotzenplotz regrets it that he except for robbery nothing learned has*  
'Hotzenplotz regrets that he has learned nothing but robbery.'

In the described configuration *es* is usually analyzed as a means of recursive sentence embedding, which functions as a structural element filling a syntactic position and referring cataphorically to the right-peripheral argument clause.

As has been already observed in traditional grammar of German the occurrence of *es* is subject to certain topological restrictions. Since German is a verb-second language, it offers a so-called prefield position.<sup>2</sup> If the *dass*-clause is topicalized to this position, *es* is obligatorily omitted, cf. (2). Also, the *dass*-clause may not be serialized adjacent to *es* in the so-called middle field, cf. (3).

- (2) Dass er außer Räuberei nichts gelernt hat, bedauert (\*es)  
*That he except for robbery nothing learned has regrets it*  
Hotzenplotz.  
*Hotzenplotz*  
'That he has learned nothing but robbery, Hotzenplotz regrets.'

- (3) weil Hotzenplotz (\*es), dass er außer Räuberei nichts gelernt  
*because Hotzenplotz it that he except for robbery nothing learned*  
hat, bedauert.  
*has regrets*  
'because Hotzenplotz regrets that he has learned nothing but robbery.'

The topological data in (2) and (3) are mostly taken as further evidence for the hypothesis that the finite clause has to be extraposed obligatorily if correlative *es* is realized. In any case, an analysis aiming at a solid treatment of the correlate-*es* construction has to cover these topological facts.

The data presented in this section mainly form the basis for existing approaches to the correlate-*es* construction.

---

<sup>1</sup>In fact, there are further infinite construction types involving *es* that are not considered in this paper, cf. Müller (1999). The presented analysis, however, can easily be transferred to these types.

<sup>2</sup>In main clauses, the prefield position results from fronting the finite verb.

### 3 The traditional view on the correlative-*es* construction

#### 3.1 Previous generative approaches

In principle, there are two competing approaches to correlative *es* in research literature. They differ fundamentally in two respects: firstly, in the analysis of the syntactic and semantic status of correlative *es*, and, secondly, in the interpretation of the grammatical relation between *es* and the linked right-peripheral finite clause.

One strand of research (e.g. Bennis 1987, Cardinaletti 1990, Sonnenberg 1992, Engel 2004) analyzes *es* as a case- and theta-marked argument of the matrix predicate. Correlative *es* projects a nominal phrase and adds a referential index to the representation. The corresponding finite *dass*-clause functions as an explicative (appositive) attribute of *es*. This view is usually implemented by adjoining the *dass*-clause to a verbal projection (V' or VP) containing *es* as a verbal argument. One consequence of this analysis is that both correlative *es* and the finite *dass*-clause constitute two independent constituents to the representation.

The other strand of research holds that correlative *es* and the finite *dass*-clause form together just one (discontinuous) nominal constituent (e.g. Zimmermann 1993, Zifonun 1995, Müller 1996, Sudhoff 2003, Sternefeld 2006) that is subcategorized and theta-marked by the matrix predicate. In this constellation *es* behaves like an expletive, which is linked to the extraposed *dass*-clause. The specific approaches of this analysis variant differ with respect to the way the *dass*-clause is integrated into the nominal phrase containing *es*. Müller (1996) and Sudhoff (2003) propose that *es* acts as the functional head of this nominal phrase and obligatorily selects the *dass*-clause as its complement. Zimmermann (1993) argues that the *dass*-clause modifies the maximal nominal projection.

For both presented analytical options constraint-based analyses have been developed as is discussed in more detail in the next section.

#### 3.2 Previous constraint-based approaches

The few existing previous constraint-based approaches follow the tradition of Pollard & Sag (1994), who treat English correlative constructions only. Pollard & Sag (1994) analyze English *it* as an expletive form which cannot take over any semantic role. Thus, the matrix predicate does not assign the respective role to the correlative *es* but to the finite clause, which has to be extraposed obligatorily. Pollard & Sag (1994) implement this analysis by defining the Extraposition Lexical Rule which operates on the SUBCAT list of the respective verbs. The output structure of this rule for the verb *to bother* in examples like (4) is exemplified in figure 1. In fact, the lexical rule replaces the finite clause that is selected by *to bother* by the nominal expletive *it*, and appends the finite clause to the end of the verb's SUBCAT list.

- (4) It bothers Kim that Sandy snores.

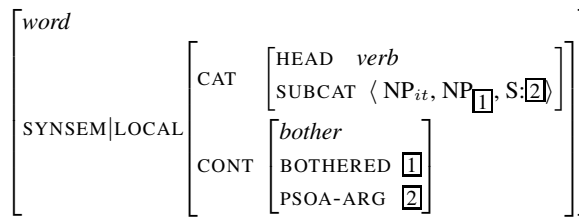

Figure 1: Output structure of Extraposition LR according to Pollard & Sag (1994)

Although the role of correlative elements in recursive sentence embedding has received considerable attention in German grammar writing and the last decades' generative theory, only a few constraint-based approaches on German have dealt with this issue so far. The two most prominent ones are those by Berman et al. (1998) and Kathol (1995).

### 3.2.1 The approach of Berman et al. (1998) couched in LFG

Berman et al. (1998) develop an unification-based analysis in the framework of lexical-functional grammar (LFG henceforth) that is based on a comparison between correlate-*es* constructions like (5) and data sets like (6). (The examples are taken from Berman et al. 1998.)

- (5) Hans hat es bedauert, dass er gelogen hat.  
*Hans has it regretted that he lied has*  
 'Hans regretted that he lied.'

- (6) a. Hans hat bedauert, dass er gelogen hat.  
*Hans has regretted that he lied has*  
 'Hans regretted that he lied.'
- b. Hans hat es bedauert.  
*Hans has it regretted*  
 'Hans regretted it.'
- c. Hans hat den Vorgang bedauert.  
*Hans has the event regretted*  
 'Hans regretted the event.'

According to Berman et al. (1998) the data in (6) indicate that the propositional argument of the matrix predicate *bedauern* ('to regret') can have several realization forms. The respective argument in the object role can be either realized by a clausal complement, i.e. a CP as in (6a) or "by the pronominal *es* which in this usage anaphorically refers to a proposition known from context" [Berman et al., 1998: 1] as in (6b). In addition, (6c) shows that in certain cases even a full nominal phrase denoting propositional entities may realize this argument. Based on these

observations Berman et al. (1998) conclude that a correlate-*es* construction like (5) results from merging constructions of the form (6a) and (6b).

Against the background of the aforementioned facts, the analysis proposed by Berman et al. (1998) relies on three basic assumptions: (i) *es* behaves like a referential pronoun, (ii) *es* and the *dass*-clause share the same argument slot of the matrix predicate in syntax but not in semantics, and (iii) the proposition introduced by the finite clause restricts the independently introduced variable of the referential pronoun *es*. The fundamental technical idea of the Berman et al. (1998) proposal concerns assumption (ii): That *es* and the *dass*-clause in fact share the same argument slot is achieved by unifying their f-structure contributions under the same function. Consequently, both *es* and the *dass*-clause differ at the categorial level—*es* is analyzed as a nominal phrase, the *dass*-clause as a clausal phrase—but share the same grammatical function OBJ(ect) at the level of grammatical functions.

The unification-based analysis proposed by Berman et al. (1998) is charming since it is not necessary to categorize the *dass*-clause syntactically as an appositive or adjoined clause although it is possible to interpret *es* referentially. Moreover, the co-occurrence of correlative *es* with a finite clause is licensed without further assumptions by general constraints on c-structures and f-structures in a LFG-fragment of German. On the other hand, the proposition introduced by the *dass*-clause semantically restricts the independently introduced variable of the referential pronoun *es* by adding more information. Hence, the finite clause behaves semantically like a typical apposition. Thus, Berman et al.'s approach follows the assumptions of standard generative approaches analyzing *es* as a referential pronoun. The main criticism of such an approach, however, is that it overlooks empirical data showing that *es* is not generally referential but may also behave like an expletive when it occurs in the context of certain verbs. The set of data substantiating this criticism is given below in section 4.

### 3.2.2 The approach of Kathol (1995) couched in HPSG

Kathol's (1995) HPSG proposal for the analysis of correlative *es* shares with the presented LFG analysis by Berman et al. (1998) the assumption that *es* has properties of a referential pronoun. Consequently, Kathol (1995) criticizes Pollard & Sag's (1994) treatment of similar constructions in English in that they analyze *it* as an expletive form that cannot carry any semantic role. Moreover, Kathol (1995) points out that in Pollard & Sag's (1994) approach the intuition is not reflected that there is a linkage between the correlative forms (*it* in English and *es* in German) on the one side and the extraposed clause on the other side. Kathol claims that any analysis should convey the observation that the correlative *es* somehow signals the presence of the propositional argument later in the clause.

Unlike Berman et al. (1998), Kathol (1995) does not act on the syntactic level of grammatical functions but on the semantic level of argument structure by reversing the relationship between syntactic complements and their semantic representations in the correlate-*es* construction: The thematic role previously thought to

be borne directly by the propositional argument is now assigned to the correlative *es* directly. The direct consequence of such an assumption is that *es* is interpreted referentially because an expletive cannot take over any thematic role by definition. Another consequence is that the propositional argument cannot carry the thematic role any more. In other words, the finite *dass*-clause cannot function as direct semantic argument of the respective matrix predicate because the referentially used *es* saturates the respective argument position. Kathol suggests that the clausal argument is instead linked to the role assigned to the index of *es*, and that this linkage is established via a relational CONTEXT feature called ANCHOR. The *anchor* relation takes two arguments: the restricted nominal index of *es* and the index of the correlated clause being of sort *parameterized states-of-affairs*. With the lexical entry given in figure 2 Kathol (1995) illustrates this analysis for the verb *stören* (‘to bother’) in an example like (7).

- (7) *dass es Kim stört, dass Sandy schnarcht.*  
*that it Kim bothers that Sandy snores*  
 ‘that it bothers Kim that Sandy snores.’

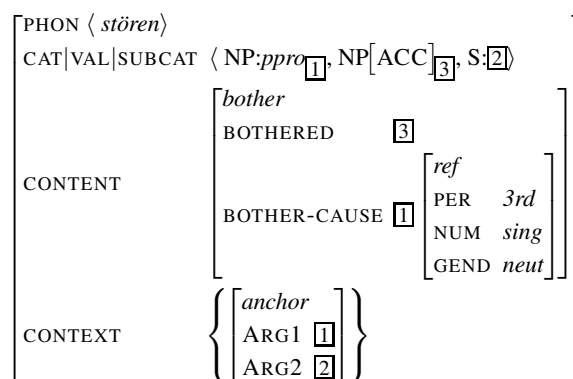

Figure 2: Lexical entry with correlative according to Kathol (1995)

In fact Kathol (1995) uses the *anchor* relation for two purposes. Firstly, it is supposed to cope with the aforementioned intuition that the correlative forms are in some sense linked to the constituent they are correlated with. Secondly, the *anchor* mechanism is needed for technical reasons to avoid a sort mismatch which would be the consequence if the indices of the correlative (which is a restricted nominal index of sort *ppro*) and the clausal argument (which is of sort *psoa*) were structure-shared directly.

Last but not least it should be mentioned that the topological generalizations on order in correlate-*es* constructions, which have been presented in section 2, are captured in Kathol’s linearization-based approach by an additional constraint accessing the *anchor* relation. Roughly speaking, it says that a constituent whose

content value is linked via an *anchor* relation to the index of some other entity is required to occur in an extraposed position.

### 3.3 Summing up

If one evaluates the various proposals discussed above, it turns out that in a sense all of them are right, but each of them may account only for a partial data set. Neither of the existing approaches is able to account for German correlative *es* in its entirety. The main reason for this is that all previous approaches overlook the fact that correlative *es* may behave like both an expletive and as a referential pronoun depending on the respective syntactic context. In particular, existing constraint-based approaches suffer from the lopsided view on *es* as a referential pronoun.

In the following section I will present corpus-based support for the hypothesis that the German correlative *es* distinguishes between two realization forms: an anaphoric referential pronoun and a true expletive. Pütz (1975) has already stated that these two types of correlative *es* may exist. His claim, however, is based on introspection and does not rest on empirical data.

## 4 Empirical evidence for the Janus-faced nature of *es*

In this section, I will argue on the basis of empirical data that correlative *es* is homonymous between an expletive and a referential form. A first step in proving this hypothesis is the evaluation of so-called correlate-taking verbs.

It is a well-established assumption of standard German grammar that verbs may be classified with respect to their ability to select correlative *es*. Surprisingly, there is no consensus in research literature when it comes to this classification. For instance, so-called *verba dicendi* and *sentiendi* like *sagen* ('to say'), *meinen* ('to think'), *hören* ('to hear'), *behaupten* ('to assert'), etc. are sometimes ranked as correlate-taking and sometimes as correlate-rejecting. The list of inconsistently classified verbs could be extended. One reason for the uncertainty in the evaluation of the respective verbs may be that the empirical basis of the classification is often very thin. The classifications often rely on construed examples or on unsystematically collected corpora. In the latter case a single item taken from a corpus is often regarded as sufficient evidence for a certain hypothesis. Boszák (2009) is a recent example of this fallacy.

Based on a quantitative corpus study<sup>3</sup> published in Axel, Holler & Trompelt (in press) it can be empirically substantiated that in fact there is a categorial distinction between two verb classes: With the first class of verbs (class I henceforth), correlative *es* is robustly attested. This is shown in figure 3 where the blue bars

---

<sup>3</sup>Methodically, a group of 35 verbs for which divergent judgments exist in the literature was selected. For each verb, the number of hits was limited to 1000 by random selection. Of those 1000, the first 100 examples in which the *dass*-clause really functions as the object clause of the critical verb were manually selected.



indicate the number of examples with *es*. With the second class of verbs (class II henceforth), however, correlative *es* is not attested among the hundred examples investigated as can be seen in figure 4.

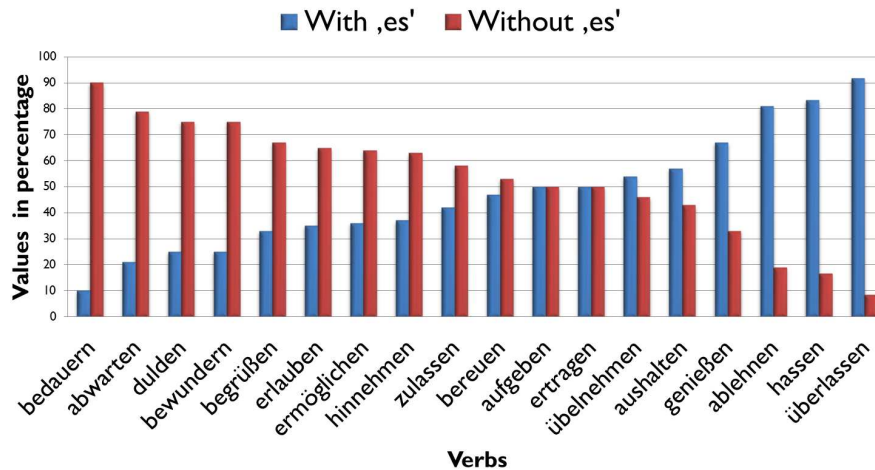

Figure 3: Corpus results for verbs of class I (Axel, Holler & Trompelt, in press)

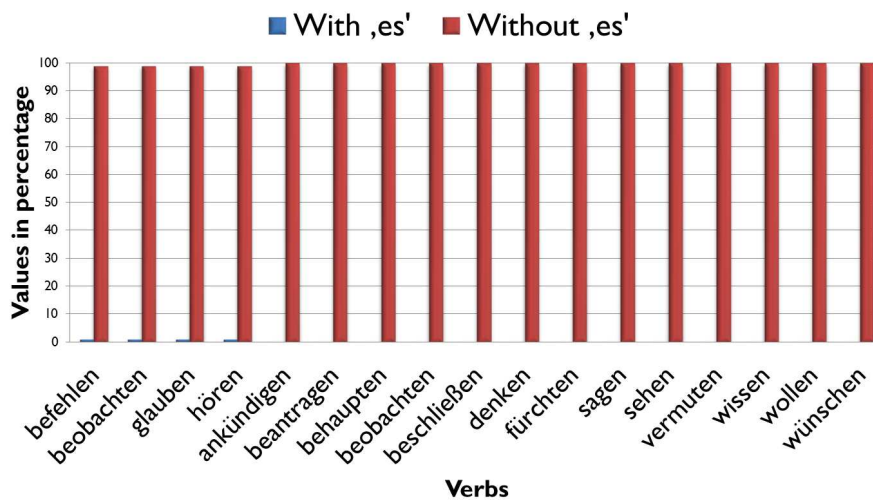

Figure 4: Corpus results for verbs of class II (Axel, Holler & Trompelt, in press)

At first glance, the result for the second verbal class is incomprehensible since it comprises verbs like *glauben* ('to believe'), *sagen* ('to say') and *wissen* ('to know') that are usually regarded as correlate-taking in German grammar theory. In fact, sporadic examples like (8), where one of these verbs is used with correlative *es*, can also be found in corpora, although the quantitatively obtained results for the second verbal class seem to be clear-cut.

- (8) Es ist schrecklich, wenn vor so vielen Dingen ein dunkler Vorhang  
*it is awful if in front of so many things a dark curtain*  
 ist. Ich möchte ihn immer nur zerreißen, aber ich kann es nicht. Ich  
*is I want to it always only tear but I can it not I*  
 glaube es dir, dass Du den Vorhang nicht zerreißen kannst.  
*believe it you that you the curtain not tear can*  
 ‘It is awful that so many things are behind a dark curtain. I believe that you  
 cannot tear the curtain.’

[TLP, 29, cited from Grammatik der Deutschen Sprache: 1487]

The puzzling empirical situation suggests to examine the direct context of the *es*-containing complex clauses with a predicate of class II in more detail. As a result of such analyses, one recognizes that in all of these cases *es* seems to refer back to a contextually given, discourse-old entity and hence behaves like an anaphoric element. In (8) the content of the *dass*-clause is discourse-old since both the curtain, and the act of tearing of the curtain are mentioned in the previous sentences. In other words, *es* seems to refer back to a contextually given, discourse-old entity. It is licensed by a potential antecedent in the left context. This suggests that correlative *es* is used as an anaphoric pro-form in these cases and not as an expletive placeholder.

Thus, the underlying reason for the divergent classification of verbs with respect to their correlate-taking ability in the literature is probably due to the Janus-faced nature of correlative *es*. Obviously, *es* occurs in two realization forms: Combined with verbs of class I it just fills a syntactic position and functions as a placeholder, which is a structural element without any semantic contribution; combined with verbs of class II, however, it must be analyzed as an anaphoric pro-form referring back to a pre-mentioned state-of-affairs.

The presented corpus evidence supports introspective data by Pütz (1975), Sudhoff (2003) and Frey (2011), who conjecture on theoretical grounds that at least two classes of putative correlative-*es*-taking verbs need to be distinguished. They claim for instance that (i) class II verbs, but not class I verbs allow *wh*-extraction and embed V2-clauses in German; (ii) class II verbs do not occur with a full NP, but class I verbs do; (iii) class II verbs, but not class I verbs occur with *dass*-clauses containing modal particles; and last but not least, (iv) class II verbs do not occur with *es* in all-focus clauses, but class I verbs do. Moreover, Axel, Holler, & Trompelt (in press) have shown in a psycholinguistic study that *es* may function as both, a non-referential structural element and a referential anaphoric pro-form. The study demonstrates that the respective usage depends on the syntactic contexts and the verbal class involved.

In view of the empirical facts, we can conclude that any analysis of the correlate-*es* construction must be able to differentiate between a placeholder and a pro-form usage of *es*, and it must mark verbs with respect to their ability to occur

with a placeholder *es* or not. Since all existing theoretical approaches of correlative *es* lack this generalization, there is still a need for a comprehensive analysis accounting for the presented empirical facts. In the next section I will outline a constraint-based analysis that complies with the homonymy of *es*.

## 5 A new constraint-based analysis for correlative *es*

As the empirical facts presented in the previous section have demonstrated, any approach claiming to cope with the correlate-*es* construction has to be able to differentiate between a placeholder and a pro-form usage of *es*, and it has to be able to mark verbs with respect to their ability to occur with a placeholder or not. In order to account for these facts, I propose an analysis of correlative *es* that is based on the following assumptions:

First, *es* is lexically homonymous between an expletive placeholder and a referential pronoun (sort *ppro*), which means that the sort hierarchy for objects of sort *nom-obj* must be extended respectively. In particular, the sort *expletive* has to be further partitioned into at least three subsorts called *placeholder-es*, *prefield-es*, and *quasi-argument-es* as depicted in figure 5. This is necessary since correlative *placeholder-es* has to be distinguished from the so-called *Vorfeld-es* (*prefield-es*), which is a specific expletive form in German to mark the first position in a verb-second clause, cf. Lenerz (1985)<sup>4</sup>, and the quasi-argument *es*, which is an expletive form acting for instance as logical subject for so-called weather-verbs.

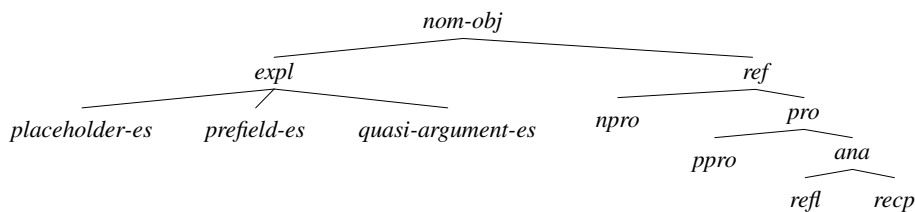

Figure 5: Partition of sort *nom-obj*

Additionally, it is assumed that expletive placeholder *es* and anaphoric pro-form *es* differ grammatically, which is also encoded in the lexicon. Figures 6 and 7 give the respective lexical entries for both realization forms of correlative *es*: *Es* as an expletive placeholder selects a clausal argument representing the finite clause. Note that this also means that the *dass*-clause is not selected by the matrix predicate. Consequently, *es* projects together with its complement, i.e. the finite clause, a nominal phrase that is case- and theta-marked by the respective matrix predicate (which must belong to the class I verbs and thus accepts placeholder *es*).

<sup>4</sup>Vorfeld-*es* is omitted if another constituent occupies the prefield, for instance as a consequence of topicalization.

In contrast to this, *es* as an anaphoric pro-form is fully saturated and has therefore an empty SUBCAT list. Contrary to expletive *es*, the finite clause is not syntactically licensed by anaphoric *es*.

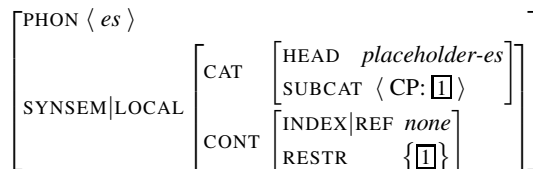

Figure 6: Lexical entry for expletive placeholder *es* (preliminary)

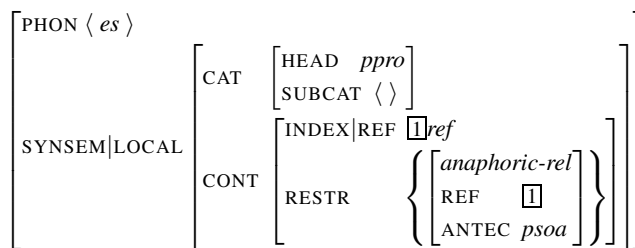

Figure 7: Lexical entry for anaphoric pro-form *es* (preliminary)

Semantically, the anaphoric pro-form *es* contributes, as any pronominal element, a referential index to the representation as well as an anaphoric relation that relates referential *es* to a suitable antecedent of sort *parameterized-state-of-affairs*.<sup>5</sup>

The placeholder *es*, however, does not make any semantic contribution on its own. It does not introduce a referential index. By itself the RESTRICTION value of the expletive placeholder *es* would equal the empty set; in fact it contains the *parameterized-state-of-affairs* which is introduced by the selected *dass*-clause. As exemplified in figure 6 this is achieved by structure-sharing the CONTENT value of the finite clause with the RESTRICTION value of placeholder *es*.<sup>6</sup>

In both cases, the proposed analysis reflects the intuition that the finite clause is linked to *es* but the nature of this linkage is different, and depends on the grammatical status of correlative *es* in each case. If *es* is an expletive, the finite clause is really selected by *es* and thus dependent on it in a closer sense. If *es* is an anaphoric pro-form, the impression of the linkage results from the resolution processes involved to satisfy the binary anaphoric relation *anaphoric-rel* introduced by pro-form *es*. It is established between *es* and its antecedent whose interpretation corresponds to the content of the finite *dass*-clause. This is the only reason

<sup>5</sup>Note that the proposed anaphoric relation resembles Kathol's *anchor* relation but it has the advantage to be motivated independently because it is introduced into the representation by any anaphoric element, not just the anaphoric pro-form *es*.

<sup>6</sup>See Müller (1999) for a similar approach.

why the *dass*-clause seems to be related to referential *es*.

The second fundamental assumption of the analysis concerns the HEAD value *verb*, which is sub-sorted in such a way that verbs can be divided lexically into placeholder-*es* taking verbs (= class I) and verbs that do not license a placeholder *es* (= class II), cf. figure 8.

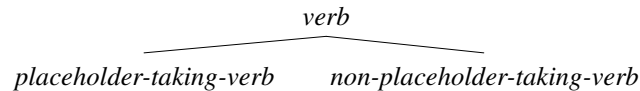

Figure 8: Partition of sort *verb*

Adopting a proposal by Sudhoff (2003), objects of these two verbal sorts differ lexically in their SUBCAT lists. While objects of sort *placeholder-taking-verb* (*ph-verb*) select a nominal argument and hence do not embed the clausal argument directly, objects of sort *non-placeholder-taking-verb* (*non-ph-verb*) are subcategorized for a clausal argument. This idea is illustrated by the partial lexical entries of the verbs *bedauern* ('to regret') and *behaupten* ('to assert') in figure 9.

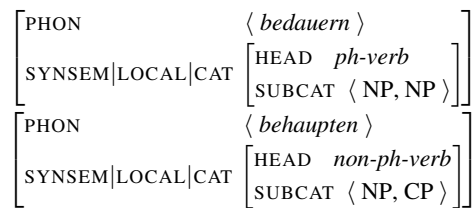

Figure 9: Verbal SUBCAT frames depending on the acceptance of a placeholder *es*

There are independent empirical reasons for the proposed differentiation of the SUBCAT lists of these two verbal classes. For instance: The outlined analysis accounts for the fact that only verbs of class I, but not of class II can occur with nominal phrases containing a full noun as the contrast between (9) and (10) demonstrates. Since verbs of sort *non-placeholder-taking-verb* select a clausal argument instead of a nominal one, as verbs of sort *placeholder-taking-verb* do, this empirical fact is captured without further assumptions. Note that the finite clause in (9a) is not dependent on the verb but it is selected by the relational noun *Tatsache*.

- (9) a. Hotzenplotz bedauert die Tatsache, dass er außer Räuberei  
*Hotzenplotz regrets the fact that he except for robbery*  
 nichts gelernt hat.  
*nothing learned has*  
 'Hotzenplotz regrets the fact that he has learned nothing but robbery.'

- b. Hans bedauert diese Tatsache.  
*Hans regrets this fact*  
 ‘Hans regrets this fact.’
- (10) a. \* Hotzenplotz behauptet die Tatsache, dass er außer Räuberei  
*Hotzenplotz asserts the fact that he except for robbery*  
 nichts gelernt hat.  
*nothing learned has*
- b. \* Hans behauptet diese Tatsache.  
*Hans asserts this fact*

Looking at the empirical facts in (11) two more remarks are necessary. First, examples like (11a) show that verbs of class I can also occur without a realized correlative *es*. To account for this fact, an additional lexical rule is needed just saying that an unstressed expletive placeholder may remain phonologically unrealized.<sup>7</sup> In other words, it is assumed that in this case the expletive *es* still selects the clausal argument but belongs to the class of *gap-ss* instead of *canon-ss* in the sense of Sag (1997) and Ginzburg & Sag (2000). Second, examples like (11b) show that an anaphoric *es* can in principle occur with verbs of class II. In addition to that, evidence that anaphoric *es* must be allowed in these cases also comes from data like (8) above. Given the selectional restrictions of verbs of sort *non-placeholder-taking-verb*, this seems to be surprising at first glance but in fact it follows from a general pronominalization rule that is needed anyway to pronominalize clausal entities.

- (11) a. Hotzenplotz bedauert, dass er außer Räuberei nichts gelernt hat.  
*Hotzenplotz regrets that he except for robbery nothing learned has*  
 ‘Hotzenplotz regrets that he has learned nothing but robbery.’
- b. Hotzenplotz behauptet {es, das}.  
*Hotzenplotz asserts it this*  
 ‘Hotzenplotz asserts {it, this}.’

The third major building block of the proposed analysis affects the finite *dass*-clause. The way of how it is related to *es* differs depending on the realization form of correlative *es*. If *es* functions as a placeholder, the *dass*-clause is a complement of *es*; if *es* functions as an anaphoric pro-form, the correlated *dass*-clause represents a non-integrated clause that behaves like an appositive (explicative) attribute. In both cases the final position of the finite clause at the right clausal edge is ensured.

Combined with a placeholder *es*, the finite clause is obligatorily extraposed, which is realized in a standard way by structure-sharing the CP-complement sub-categorized by *es* with an element of the *extra* list, cf. Keller (1994). See figure 10

<sup>7</sup>In light of examples like (2) it is necessary to implement into this constraint the requirement that the *dass*-clause is only optionally part of the EXTRA list if *es* is phonologically unrealized, in order to capture the fact that the finite clause may be topicalized in this case.

for the extended lexical entry of the placeholder *es*. From general constraints on extraposition then follows that the CP has to be positioned on the right periphery, which particularly means that it neither can be topicalized nor realized in the so-called middle field. Thus, the topological facts presented in section 2 are captured without further assumptions.

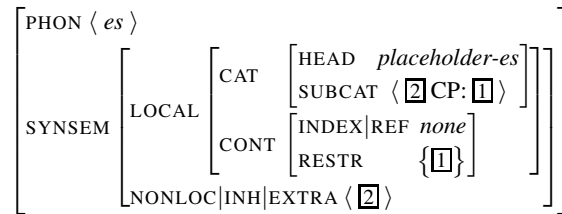

Figure 10: Lexical entry for expletive placeholder *es*

Combined with an anaphoric *es*, however, the CP behaves like an appositive clause and is thus analyzed as being of sort *fully-non-integrated*, cf. Holler (2008). Different approaches to capture non-integrated clauses have been developed. They differ basically in the way of how the non-integrated clause is connected to its host. The proposals range from radical orphanage analyses to analyses that adjoin the non-integrated clause to the highest position of the preceding clause. Which approach is adequate, is not relevant here because from any approach dealing with non-integrated clauses follows that clauses of this sort have to occur right-dislocated if not used parenthetically.

Having the status of the *dass*-clause at hand the lexical entry of pro-form *es* can be extended with respect to the specification of the antecedent that is suitable to resolve anaphoric *es* semantically. Since pro-form *es* behaves like an ordinary anaphoric element, it needs to be resolved. As has been said before the anaphoric relation introduced by *es* combines the referential index of anaphoric pro-form *es* with an entity of sort *parameterized state-of-affairs* which is introduced by the finite *dass*-clause. As the empirical facts discussed in section 4 have shown this relation can only be established if the semantic content of the finite clause is contextually given. To account for this it is required that the CONTENT value of the finite clause is contained in pro-form *es*'s BACKGROUND set. As depicted in figure 11 this is realized by structure-sharing the CONTENT value of the non-integrated *dass*-clause with an element of the BACKGROUND set. Additionally, the CONTENT value of the finite clause is accessible via the CONTEXT value of the anaphoric pro-form *es*, which contains a list of all linked, that means dependent but not embedded clauses. For more details on this differentiation see Holler (2008). The SYNSEM value of the appositive finite *dass*-clause, which is of sort *fully-non-integrated*, instantiates the LINKED list of anaphoric *es*. This is the reason why its CONTENT value is accessible and can constitute a proper antecedent of anaphoric *es*.

To illustrate the outlined approach to expletive and referential correlative *es* I will present an example analysis for both kinds of correlate-*es* constructions.

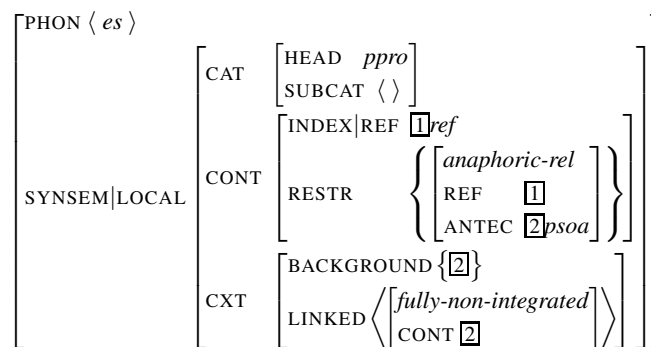

Figure 11: Lexical entry for anaphoric pro-form *es*

Beginning with the expletive placeholder *es*, figure 12 gives the partial structure for an example such as (12), which is a short version of (1). It illustrates the interplay of the lexical specification of placeholder *es* on the one hand and the requirements of the placeholder-taking verb *bedauern* ('to regret') on the other hand.

- (12) Hotzenplotz bedauert es, dass er nichts gelernt hat.  
*Hotzenplotz regrets it that he nothing learned has*  
 'Hotzenplotz regrets that he has learned nothing.'

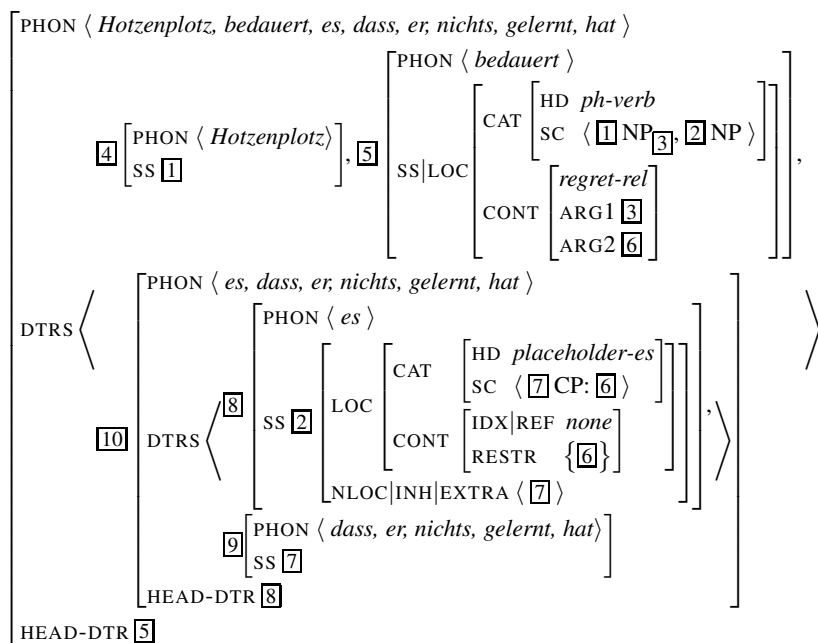

Figure 12: Example for a placeholder-*es* construction

In the attribute-value matrix depicted in figure 12, the placeholder-taking verb



*bedauern* ('to regret') functions as the HEAD daughter selecting both, the nominal subject *Hotzenplotz* (cf. tag [1]) and the expletive placeholder *es* (cf. tag [2]), which itself takes the finite clause as a complement (cf. tag [7]). According to the proposed analysis the finite clause is not dependent on the verb *bedauern*. It is instead subcategorized by the placeholder *es* (cf. tag [7]). This is the reason why the DAUGHTERS list of the whole correlate-*es* construction contains apart from the signs representing the verb *bedauern* (cf. tag [5]) and the nominal subject *Hotzenplotz* (cf. tag [4]) the complex object *es, dass er nichts gelernt hat* (cf. tag [10]). This sign is itself structured and consists of two daughters: *es* acts as the head daughter (cf. tag [8]) and the finite *dass*-clause (cf. tag [9]) acts as the complement daughter of *es*. Since its SYNSEM value is structure-shared with an element of the EXTRA list (cf. tag [7]), it is guaranteed that the *dass*-clause is realized in an extraposed position. Thus, it can neither occur in the pre-field nor in the middle field. The semantic interpretation of a correlative construction containing an expletive *es* is basically controlled by the interplay of the semantic relation introduced by the respective verb (i.e. *regret-rel*) and the lexical specification of placeholder *es*: Tag [6] marks the structure-sharing of the CONTENT value of the finite *dass*-clause with the RESTRICTION value of expletive *es*, which saturates the respective semantic role of *bedauern*. Note that expletive *es* does not contribute a referential index to the representation.

In the case of a non-placeholder-taking verb like *behaupten* ('to assert') occurring with the anaphoric proform *es* the partial analysis in figure 13 shows that the DAUGHTERS list of a correlate-*es* construction for an example such as (13)<sup>8</sup> contains four signs: Apart from the sign representing the verb *behaupten* and functioning as the HEAD-daughter of the clausal structure (cf. tag [5]), the signs representing the subject *Hotzenplotz* (cf. tag [6]), the anaphoric proform *es* (cf. tag [7]), and the non-integrated finite clause stand on the DAUGHTERS list (cf. tag [9]).

- (13) [...] Hotzenplotz behauptet es, dass er nichts gelernt hat.  
*Hotzenplotz asserts it that he nothing learned has*  
 '[...] Hotzenplotz asserts that he has learned nothing.'

In contrast to the analysis of the correlate-*es* construction with an expletive placeholder *es*, the *dass*-clause is not selected by *es*. Instead it is analyzed as being syntactically non-integrated, which means that it is of sort *fully-non-integrated*. Clauses of this sort are part of the LINKED list representing the syntactic context. Semantically, the CONTENT value of the *dass*-clause (cf. tag [8]) resolves the anaphoric referent introduced by *es* (cf. tag [4]). This is indicated by the relation *anaphoric-rel* added to the representation by *es*. Most important is the assumption that the finite *dass*-clause must be given that means it must be pre-mentioned in the left context. This fact is represented by the BACKGROUND set containing the CONTENT value of the finite clause (cf. tag [8]).

<sup>8</sup>Note that example (13) cannot be uttered out-of-the-blue. It is only adequate if the content of the *dass*-clause is pre-mentioned in the right context. [...] marks this aspect.

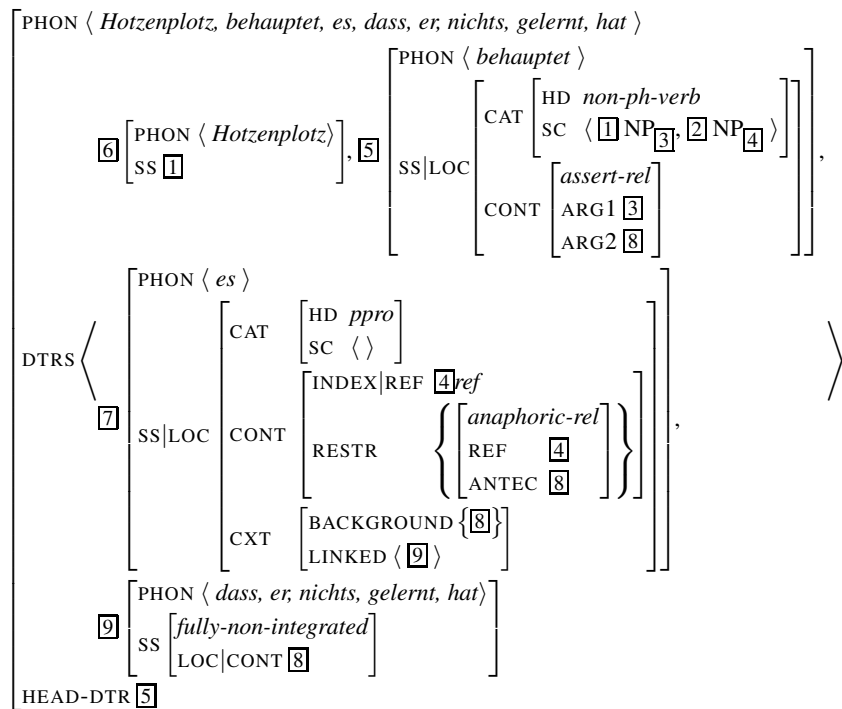

Figure 13: Example for an anaphoric proform-*es* construction

## 6 Conclusion

In the present article it has been argued that correlative *es* functions either as an expletive placeholder, which is a structural element without any semantic value, or as an anaphoric pro-form, which must be resolved by a suitable state-of-affairs. It has been shown empirically that the placeholder versus anaphoric use of correlative *es* is both verb-class dependent and context dependent. To account for these empirical facts the constraint-based analysis outlined in this article differentiates lexically between *es* as an expletive and *es* as a referential pronoun. As an expletive *es* is analyzed as a functional element without an own semantic contribution, but selecting a finite clausal argument. As a referential pronoun, there are three points to consider: Firstly, *es* is syntactically fully saturated; secondly, it contributes semantically a referential index to the representation; and thirdly, it needs to be resolved. Correspondingly, the dependent *dass*-clause is either selected by the expletive *es* or act as a syntactically non-integrated clause, which resolves semantically the anaphoric relation introduced by pro-form *es*. In the first case the *dass*-clause has to be extraposed obligatorily, in the latter case it follows from its non-integratedness that the *dass*-clause is positioned on the right periphery. It is to be expected that the analysis presented here can be transferred to other languages possessing correlative elements such as Dutch and Italian. This should be

examined carefully in further research.

## References

- Axel, Katrin, Anke Holler & Helena Trompelt. In print. Correlative *Es* vs. *Das* in German: An Empirical Perspective. In Kerstin Schwabe, André Meinunger & Werner Frey (eds.), *Inner-sentential propositional pro-forms*, Amsterdam/Philadelphia: John Benjamins.
- Bennis, Hans. 1987. *Gaps and Dummies*. Dordrecht/Providence: Foris Publications.
- Berman, Judith, Stefanie Dipper, Christian Fortmann & Jonas Kuhn. 1998. Argument clauses and correlative *es* in German — deriving discourse properties in a unification analysis. In Miriam Butt & Tracy Holloway King (eds.), *Proceedings of LFG98 conference*, Stanford: CSLI Publications.
- Boszák, Gizella. 2009. *Realisierung der valenzbestimmten Korrelate des Deutschen*. Frankfurt/M. u.a.: Peter Lang.
- Cardinaletti, Anna. 1990. *Impersonal Constructions and Sentential Arguments in German*. Padova: Unipress.
- Engel, Ulrich. 2004. *Deutsche Grammatik*. München: Iudicium.
- Frey, Werner. 2011. On the nominal character of clauses associated with a pronominal. Ms.
- Ginzburg, Jonathan & Ivan A. Sag. 2000. *Interrogative Investigations: the form, meaning, and use of English interrogatives*. Stanford: CSLI.
- Holler, Anke. 2008. German dependent clauses from a constraint-based perspective. In Cathrine Fabricius-Hansen & Wiebke Ramm (eds.), *Subordination vs. coordination in sentence and text.*, 187–216. Amsterdam/Philadelphia: John Benjamins.
- Kathol, Andreas. 1995. *Linearization-Based German Syntax*: Ohio State University dissertation.
- Keller, Frank. 1994. Extraposition in HPSG. Ms.
- Lenerz, Jürgen. 1985. Zur Theorie des syntaktischen Wandels: das expletive *es* in der Geschichte des Deutschen. In Werner Abraham (ed.), *Erklärende Syntax des Deutschen*, 99–136. Tübingen: Narr.
- Müller, Gereon. 1996. On Extraction and Successive Cyclicity. In Ulrich Lutz & Jürgen Pafel (eds.), *On Extraction and Extraposition in German*, 213–244. Amsterdam/Philadelphia: John Benjamins.

- Müller, Stefan. 1999. *Deutsche Syntax deklarativ. Head-Driven Phrase Structure Grammar für das Deutsche*. Tübingen: Max Niemeyer.
- Pollard, Carl & Ivan Sag. 1994. *Head-driven Phrase Structure Grammar*. Stanford/Chicago: CSLI Publications and University of Chicago Press.
- Pütz, Herbert. 1975. *Über die Syntax der Pronominalform es im modernen Deutsch*. Tübingen: Narr.
- Sag, Ivan A. 1997. English Relative Clause Constructions. *Journal of Linguistics* 33(2). 431–484.
- Sonnenberg, Bernhard. 1992. *Korrelate im Deutschen: Beschreibung, Geschichte und Grammatiktheorie*. Tübingen: Max Niemeyer.
- Sternefeld, Wolfgang. 2006. *Syntax. Eine morphologisch motivierte generative Beschreibung des Deutschen*. Tübingen: Stauffenburg.
- Sudhoff, Stefan. 2003. *Argumentsätze und es-Korrelate — zur syntaktischen Struktur von Nebensatzeinbettungen im Deutschen*. Berlin: Wissenschaftlicher Verlag.
- Zifonun, Gisela. 1995. Minimalia grammaticalia: das nicht-phorische es als Prüfstein grammatischer Theoriebildung. *Deutsche Sprache* 23. 39–60.
- Zifonun, Gisela, Ludger Hoffmann & Bruno Strecker. 1997. *Grammatik der deutschen Sprache*. Berlin/New York: de Gruyter.
- Zimmermann, Ilse. 1993. Zur Syntax und Semantik der Satzeinbettung. In Inger Rosengren (ed.), *Satz und Illokution* 2, 231–251. Tübingen: Max Niemeyer.