

# Analogy-based morphology: The Kasem number system

Matías Guzmán Naranjo 

Université Paris Diderot

Proceedings of the 26th International Conference on  
Head-Driven Phrase Structure Grammar

University of Bucharest

Stefan Müller, Petya Osenova (Editors)

2019

Stanford, CA: CSLI Publications

pages 26–41

Keywords: proportional analogy, morphology, Kasem, HPSG

Guzmán Naranjo, Matías. 2019. Analogy-based morphology: The Kasem number system. In Stefan Müller & Petya Osenova (eds.), *Proceedings of the 26th International Conference on Head-Driven Phrase Structure Grammar, University of Bucharest*, 26–41. Stanford, CA: CSLI Publications. DOI: 10.21248/hpsg.2019.2.



## Abstract

This paper presents a formalization of proportional analogy using typed feature structures, which retains all key elements of analogical models of morphology. With the Kasem number system as an example, I show that using this model it is possible to express partial analogies which are unified into complete analogies. This paper is accompanied by a complete TRALE implementation.

Proportional analogy (PA) approaches to morphology are grounded on the idea that inflection systems are made up of relations between fully inflected items of a paradigm (Blevins, 2006, 2007, 2008, 2016; Neuvel, 2001; Singh et al., 2003; Singh & Ford, 2003) instead of individual morphemes, positions classes, morphological processes, rule blocks, etc. Proportional analogies are usually written as A:B::C:D, meaning that A is to B as C is to D. For example, a number of Kasem nouns exhibits the following relation between singular and plural: *agsɪ:agsa* ('candy'), which, modulo ATR harmony, can be generalized to: (sg)*Xɪ:Xa*(pl). Using this analogy, we can deduce the singular form *alapɪɪɪ* ('airplane') from its plural *alapɪɪɪɪ*. This analogy has the property that it is a non-directional relation, i.e. there is no stem from which the singular and the plural are formed, nor does the singular serve as the base for the plural and vice versa.

Analogical models of morphology are attractive for several reasons. First of all, they make very few assumptions and are conceptually very simple. In PA models, there is no need for stems, bases, morphemes, or other sublexical elements besides those needed in the phonology. Second, PA can capture relations between any two cells in a paradigm, something which realizational approaches sometimes struggle with. Despite those advantages, there have been no serious attempts at formalizing proportional analogy. Additionally, the lack of formalization has the consequence that we do not know what the limits of PA are. It is unclear whether or not morphological systems which cannot be captured analogically exist. Neither do we know what the formal properties of PA are in morphology.

This paper presents a formalization of a purely analogical model of morphology in HPSG. The system uses reentrancies and append to express analogies between the cells of a paradigm. Combined with the use of underspecification and multiple inheritance, this model is able to express partial analogies for various morphological processes. As a case study, I present a partial analysis of the Kasem number system. This paper is accompanied by a full implementation in TRALE (Meurers et al., 2002; Penn, 2004; Müller, 2007).<sup>1</sup>

## 1 Kasem number classes

I will focus on the Kasem (Howard, 1969, 1970; Niggli & Niggli, 2007) number system as an illustrative example of complex multiple inheritance in inflectional

---

<sup>†</sup>I thank the anonymous reviewers and conference participants for their helpful comments.

<sup>1</sup>The code can be found at <https://gitlab.com/abm-collection/kazem>.

morphology (Guzmán Naranjo, 2019). Kasem nouns inflect for singular and plural; the challenge consists in the large number of inflection classes. Number inflection in Kasem can be analyzed as being composed of two non-suffixal (*stem*) processes, one or two suffixal singular markers, and one or two suffixal plural markers.

Like other West African languages, Kasem has ATR harmony with five +ATR vowels (ə, e, i, o, u), and five -ATR vowels (a, ε, ɪ, ɔ, v). Contrasts are shown in (1). Besides a small number of exceptions, all vowels in a word must have the same ATR value as shown in (1). However, ATR harmony does not need to hold across members of a compound, as can be seen in (2). To abstract away from ATR harmony, I will use capital letters to represent Kasem vowels (A, E, I, O, U).

(1)	singular	plural	gloss	
a.	colo	cwəlu	‘kilogram’	+
b.	cɔɓ	cwaalu	‘girl that likes going out with men’	-
c.	peeli	peelə	‘shovel, spade’	+
d.	pɛɪɪ	pɛɛla	‘bean cake’	-
f.	vəlu	vələ	‘traveller’	+
e.	valv	vala	‘farmer’	-
g.	yiri	yirə	‘type, kind’	+
h.	yɪɪ	yɪra	‘name’	-

(2)	singular	gloss
a.	tɔn-yeenu	‘scholar, scientist’
b.	tapwal-bu	‘kidney’
c.	kalon-ɔɔŋɔ	‘Martial Eagle’
d.	bugə-ɔɔŋɔ	‘tree species’

The singular is marked by a vowel and sometimes also by a consonant in the final syllable. There are at least 10 different singular vowel markers shown in (3)<sup>2,3</sup>. There is no obvious systematicity between singular and plural vowel marker combinations.

<sup>2</sup>Since tone is identical for singular and plural forms, tone marking is omitted in the present paper.

<sup>3</sup>I base the analysis on the dictionary by Niggli & Niggli (2007). Some speakers report forms different from those in the dictionary (Zaleska, 2017).

	singular	plural	sg marker	gloss
(3) a.	banyuru	banyuru	∅	'guinea-corn'
b.	vwe	vwə	E	'shelter'
c.	nabara	nabaru	A	'river'
d.	tεε	taa	EE	'sling'
e.	nu-nakwɪ	nu-nakwa	I	'grandmother'
f.	surbiu	surbe	IA	'kind of plant'
g.	pupɔnɔ	pupwaanu	O	'manure'
h.	diinu	diinə	U	'rodent'
i.	kayaa	kayε	AA	'round straw basket'
j.	bii	biə	II	'marble, ball'

Singular consonant markers are shown in (4). There are two types of consonant markers: onset consonants in the final syllable and coda consonants in the final syllable. Nouns can only use one of those two strategies.

	singular	plural	sg marker	gloss
(4) a.	ɲwam-pugv	ɲwam-purru	-g-	'scale of wound'
b.	gwaka	gwagsɪ	-k-	'luggage rack'
c.	natoŋo	nantwəənu	-ŋ-	'roof vent'
d.	coro	ceeni	-r-	'hen, fowl, chicken'
e.	kukɔnɔ	kukwaru	-n-	'kind of fish'
f.	lu-sɪwn	lu-suru	-n	'metal sponge'
g.	mɪm	mɪna	-m	'millet'
h.	doŋ	donnə	-ŋ	'mate, fellow'

As singular forms, plural forms are marked by a vowel and sometimes by a consonant in their final syllable. The examples in (5) and (6) show vowel and consonant markers for the plural, respectively. Although there are some striking similarities between singular and plural markers, there is more variety in the singular than in the plural.

	singular	plural	pl marker	gloss
(5) a.	manduru	mandurru	∅	'spoon'
b.	manlaa	manlε	E	'chameleon'
c.	tɪgaguru	tɪgagura	A	aardvark
e.	tεε	taa	AA	'sling'
d.	gwala	gwalɪ	I	'slave rider'
e.	bu	biə	IA	'fruit, grain'
f.	kogo	koru	U	'kind of shrub'

	singular	plural	pl marker	gloss
(6) a.	sugv	sum	-m	'knife, razor'
b.	vɔsaŋa	vɔsɛn	-n	'type of shrub'
c.	nuŋv	nuŋnu	-n-	'marrow'
d.	balogo	balwəru	-r-	'lizard'
e.	karga	karst	-s-	'mite, bug'

Finally, there are two non-affixal processes which mark the plural: lengthening of the vowel of the penultimate syllable, gemination of the onset of the final syllable, and diphthongization of the vowel of the penultimate syllable. As shown in (7),<sup>4</sup> these two processes can occur either separately (a-e) or together (f-k).

	singular	plural	gloss
(7) a.	lam-po	lam-pooru	'tax'
b.	le-mu	le-muuru	'orange'
c.	ka-len-zi-u	ka-len-zi-i-ru	'basket for fishing'
d.	to-ku-nu	to-ku-nnu	'seeds of baobab fruit'
e.	su-ru	su-rru	'shrub species'
f.	pɔ-ɔ	p-wallv	'saddle, seat'
g.	tas-ɔ-ɔ	tas-waarv	flint lighter
h.	so-ro	swə-ə-ru	mucilaginous herb used in soup
i.	yo-lo	y-wallu	'bag, sack'
j.	ni-viu	ni-vweeru	'mouth breath'
k.	ni-u	nweeru	'mirror, glass'

Besides the segmental markers discussed so far, the singular is related to the plural by one of six possible alternations shown in (8).<sup>5</sup> The alternations  $X\sigma-X$  (a-c) and  $X-X\sigma$  (d-f) are the mirror image. In  $\sigma-0$ , the singular has one syllable more than the plural, whereas in  $X-X\sigma$ , the plural has one syllable more than the singular. There is a correspondence between the syllables denoted by X, although this correspondence is mediated by non-suffixal markers such as lengthening and diphthongization. In the alternation  $X\sigma-X\sigma$  (g-h), the singular and the plural have the same number of syllables, but there is no strict correspondence between the final syllable. The following three alternations form subtypes of this alternation. The alternation  $X-X$  (i-j) applies when the singular and the plural are identical (modulo lengthening and diphthongization). In  $XV-XV$  (k-l), only the vowel of the final syllable varies, while in  $XOY-XOY$ , only the onset of the final syllable varies (again modulo lengthening and diphthongization).

<sup>4</sup>There are two additional vowel mutations which I will not address in this paper.

<sup>5</sup>There are some additional fixed singular-plural alternations which do not interact with any individual affixal marker or non-affixal process. I do not discuss those in this paper.

	singular	plural	pattern	gloss
a.	<i>zvŋa</i>	<i>zwt</i>	$X\sigma$ - $X$	‘calabash’
b.	<i>sigə</i>	<i>si</i>	$X\sigma$ - $X$	‘Hartebeest’
c.	<i>kapa-svŋa</i>	<i>kapa-sun</i>	$X\sigma$ - $X$	‘Cobra’
d.	<i>kalanjoo</i>	<i>kalanjooru</i>	$X$ - $X\sigma$	‘clam’
e.	<i>kən</i>	<i>kəna</i>	$X$ - $X\sigma$	‘Antelope’
f.	<i>tangwam</i>	<i>tangwana</i>	$X$ - $X\sigma$	‘earth shrine’
(8) g.	<i>kaman-poŋo</i>	<i>kaman-pwənnu</i>	$X\sigma$ - $X\sigma$	‘white maize’
h.	<i>cəgə</i>	<i>cərv</i>	$X\sigma$ - $X\sigma$	‘pond’
i.	<i>kantwana</i>	<i>kantwana</i>	$X$ - $X$	‘sp. of fruit’
j.	<i>suru</i>	<i>surru</i>	$X$ - $X$	‘sp. of shrub’
k.	<i>lampo-joŋnu</i>	<i>lampo-joŋnə</i>	$XV$ - $XV$	‘tax-collector’
l.	<i>kog-zono</i>	<i>kog-zwəənu</i>	$XV$ - $XV$	‘sp. of shrub’
m.	<i>cujv</i>	<i>cinnu</i>	$XOY$ - $XOY$	‘tapeworm’
n.	<i>tasugu</i>	<i>tasuru</i>	$XOY$ - $XOY$	‘covering lid’

Affixal markers, non-affixal markers, and alternations being simple on their own, the system shows considerable complexity in that it has around 150 classes which arise from the combinations of individual markers and alternations. Most of the singular markers can appear together with most of the plural markers, and in several different singular–plural relations. Although many combinations are not attested, it is not evident whether these gaps are accidental or caused by hard grammatical constraints. I do not attempt to explain these gaps in this paper.

The previous discussion of Kasem is not complete, and there are additional non-affixal and affixal markers in the system. However, the classes described in this paper account for around 80% to 85% of Kasem nouns listed in Niggli & Niggli (2007).

## 2 Analogy-based Morphology: Kasem

The basic assumption of AbM (Analogy-based Morphology) is that lexemes list all their inflected forms.<sup>6</sup> This comes directly from the idea in PA models that lexemes are the set of inflected forms in a paradigm (Blevins, 2016).<sup>7</sup> In the case of Kasem, nouns list their singular and plural forms as in Figure 1.<sup>8</sup> Unlike the representations used by Bird & Klein (1994) and Monachesi (2005) which avoid the use of explicit syllable trees, both SINGULAR and PLURAL are lists of syllables.

<sup>6</sup>Or at least all forms which take part in analogical relations.

<sup>7</sup>I use attribute-value pairs to represent each paradigm cell. While there are possible alternatives which might be compatible with the general HPSG architecture, this approach is the most straightforward for making it computationally implementable in TRALE.

<sup>8</sup>I will sometimes omit the PARADIGM feature to save space in the AVMs.

The representations of phonemes, vowels, and syllables are given in Figures 2–6. Although more complex representations are possible, the distinctions made here are sufficient to capture the Kasem number system. The `CORE` feature in Figure 2 is a shorthand notation for the complete specification of place and manner of articulation of a segment (Bird & Klein, 1994), which does not play a direct role in the morphological analogies. These structures are organized as in the partial hierarchy in Figure 7.

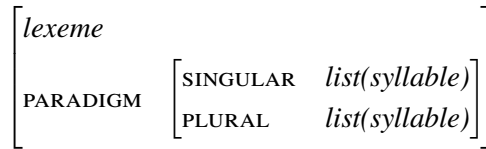

Figure 1: Lexeme

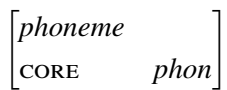

Figure 2: Phoneme

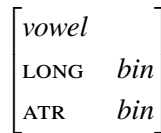

Figure 3: Vowel

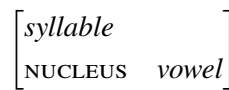

Figure 4: Syllable

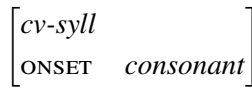

Figure 5: CV Syllable

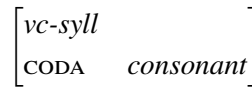

Figure 6: VC Syllable

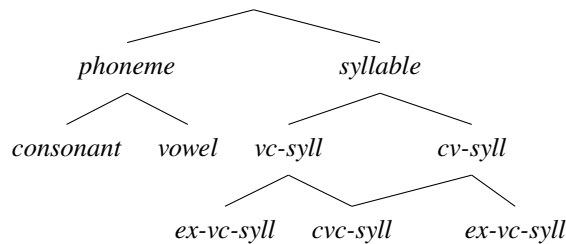

Figure 7: syllable-phoneme hierarchy

Given those simple assumptions, we can express complete analogical relations as constraints on the `SINGULAR` and `PLURAL` features. For instance, the complete analogy for nouns such as *agst-agsa* (‘candy’), which have non-alternating stems and *-I/-A* markers, is shown in Figure 8.

However, from the perspective of traditional PA models, a particularly challenging aspect of Kasem is the existence of number markers that behave independently of each other. To give an example, we need to be able to express the fact

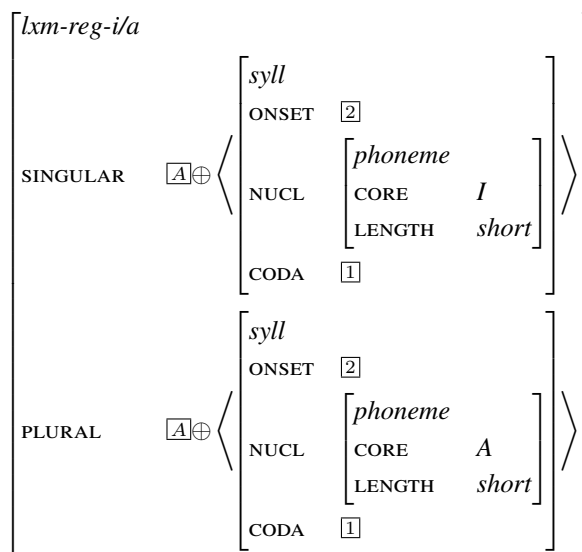

Figure 8: Non-alternating-A-I

that *-O* and *-I* are singular markers independently of the plural marker they appear in opposition to. This generalization runs opposite to PA models, which usually claim that morphological systems rely exclusively on oppositions. However, we would miss an important generalization without being able to express these partial patterns. Similarly, we need to be able to express non-affixal markers (lengthening and diphthongization) as independent processes, which can occur together, and with different suffix combinations. To model these facts, we need to decompose complete analogical relations into partial analogies.

We start by defining non-affixal relations. Figure 9 describes the analogy which ensures no lengthening. The reentrancies in the feature *LONG* ensure that there are no discrepancies between the length of the singular and the plural vowels of the penultimate syllable,<sup>9</sup> while the constraints of the coda ensures that there is no gemination of the consonant.

The opposite, vowel and consonant lengthening, is achieved by the constraints in Figures 10 and 11, respectively. In Figure 10, we impose the constraint that the nucleus of the penultimate syllable of the plural must be long. The constraint in Figure 11 ensures that the coda of the penultimate and onset of the final syllables of the plural are identical to the onset of the final syllable of the singular, and that the penultimate syllable of the singular is CV.

<sup>9</sup>I treat cases where both the singular and the plural have a long penultimate syllable as cases of no lengthening.



$$\left[ \begin{array}{l} \text{no-lengthening} \\ \text{sing } \boxed{1} \oplus \left\langle \left[ \begin{array}{l} vc \\ \text{NUCL } \boxed{2} \\ \text{CODA } \boxed{3} \end{array} \right], [\text{syll}] \right\rangle \\ \text{plur } \boxed{1} \oplus \left\langle \left[ \begin{array}{l} vc \\ \text{NUCL: } \boxed{2} \\ \text{CODA } \boxed{3} \end{array} \right], [\text{syll}] \right\rangle \end{array} \right] \vee \left[ \begin{array}{l} \text{no-lengthening} \\ \text{sing } \boxed{1} \oplus \left\langle \left[ \begin{array}{l} \text{excl-cv} \\ \text{NUCL } \boxed{2} \end{array} \right], [\text{syll}] \right\rangle \\ \text{plur } \boxed{1} \oplus \left\langle \left[ \begin{array}{l} \text{excl-cv} \\ \text{NUCL: } \boxed{2} \end{array} \right], [\text{syll}] \right\rangle \end{array} \right]$$

Figure 9: No lengthening

$$\left[ \begin{array}{l} \text{v-lengthening} \\ \text{SING } \boxed{1} \oplus \left\langle \left[ \begin{array}{l} vc \\ \text{NUCL|LONG -} \end{array} \right], [\text{syll}] \right\rangle \\ \text{PLUR } \boxed{1} \oplus \left\langle \left[ \begin{array}{l} vc \\ \text{NUCL|LONG +} \end{array} \right], [\text{syll}] \right\rangle \end{array} \right]$$

Figure 10: V-lengthening

$$\left[ \begin{array}{l} \text{c-lengthening} \\ \text{SING } \boxed{1} \oplus \left\langle \left[ \begin{array}{l} \text{excl-cv} \\ \text{ONSET } \boxed{2} \end{array} \right] \right\rangle \\ \text{PLUR } \boxed{1} \oplus \left\langle \left[ \begin{array}{l} vc \\ \text{CODA } \boxed{2} \end{array} \right], \left[ \begin{array}{l} cv \\ \text{ONSET } \boxed{2} \end{array} \right] \right\rangle \end{array} \right]$$

Figure 11: C-lengthening

Figures 12 and 13 ensure no diphthongization and diphthongization to occur, respectively. No diphthongization is achieved by enforcing that the CORE of the nucleus of the penultimate syllables of the singular and the plural are identical. Diphthongization is expressed by directly specifying the CORE value of the singular as /O/ and the CORE value of the plural as /WE/.<sup>10</sup>

$$\left[ \begin{array}{l} \text{no-diphthong} \\ \text{sing } \boxed{1} \oplus \left\langle \left[ \begin{array}{l} \text{syll} \\ \text{NUCLEUS } \boxed{2} \end{array} \right], [\text{syll}] \right\rangle \\ \text{plur } \boxed{1} \oplus \left\langle \left[ \begin{array}{l} \text{syll} \\ \text{NUCLEUS: } \boxed{2} \end{array} \right], [\text{syll}] \right\rangle \end{array} \right]$$

Figure 12: No diphthongization

The partial hierarchy in 14 captures the possible combinations of non-affixal processes.

Vowel and consonant suffixal markers can be captured in a straightforward way

<sup>10</sup>Similar constraints must be introduced for other cases of diphthongization.

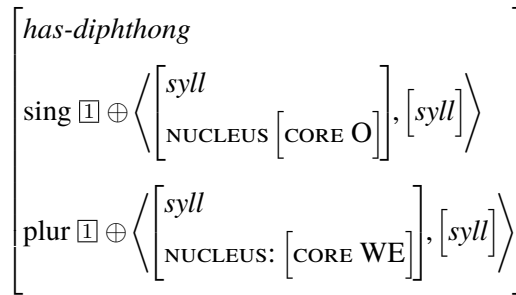

Figure 13: Diphthongization

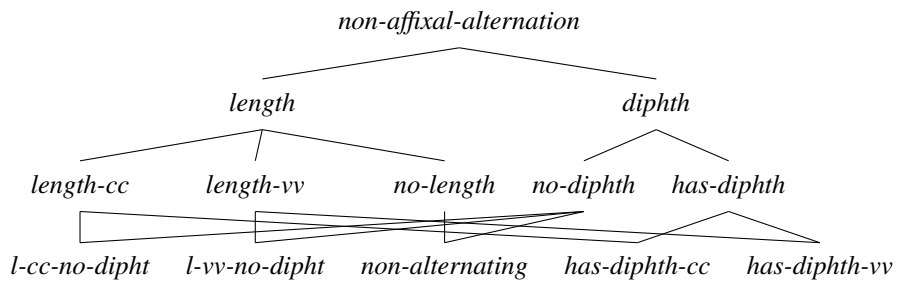

Figure 14: Non-affixal hierarchy

as well. Figures 15 and 16 give examples of vowel markers, and Figures 17 and 18 show different consonant markers.

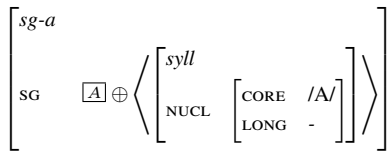

Figure 15: Suffixal marker -A

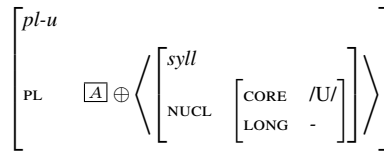

Figure 16: Suffixal marker -U

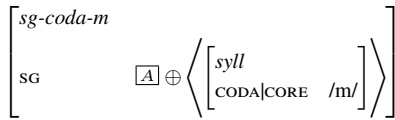

Figure 17: Suffixal marker -m

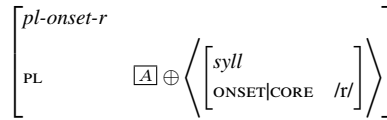

Figure 18: Suffixal marker -r-

Finally, the 6 analogical relations are what links the singular to the plural. Figures 19 to 24 present those patterns. Relation  $X\sigma-X\sigma$  states that both the singular and the plural have the same number of syllables and the onsets of their penultimate syllables are identical. This relation also states that the ATR value of the singular

and the plural must be identical on a syllable-by-syllable basis.<sup>11</sup> As mutation only occurs in the final two syllables, we state that all preceding syllables are identical for the singular and the plural.

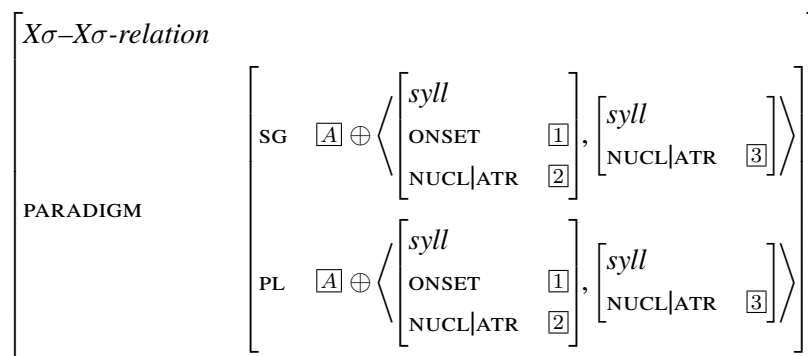

Figure 19: Relation  $X\sigma-X\sigma$

Relation  $X\sigma-X$  states that the singular has all the syllables of the plural plus one additional syllable. Because this relation does not allow for vowel lengthening in the plural the CORE of the penultimate syllables in both cells are identical. However, this relation does allow for additional consonant markers in the plural. Relation  $X-X\sigma$  is almost the mirror image of relation  $X\sigma-X$ , allowing for diphthongization and lengthening in the plural.

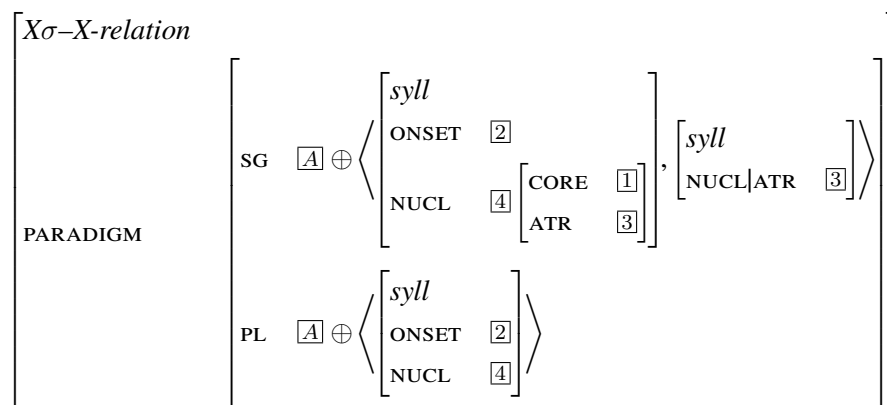

Figure 20: Relation  $X\sigma-X$

Relations  $XV-XV$  and  $XOY-XOZ$  are subtypes of relation  $X\sigma-X\sigma$ ; however, they impose additional constraints. Relation  $XV-XV$  states that the onset of the final syllable of both cells must be identical, while relation  $XOY-XOZ$  requires that the nucleus of the final syllable of both cells be identical. Finally, relation  $X-X$  simply states that, modulo lengthening and diphthongization, the singular and

<sup>11</sup>Since compounds can break ATR harmony, we cannot state that the final and penultimate syllables have the same ATR value.

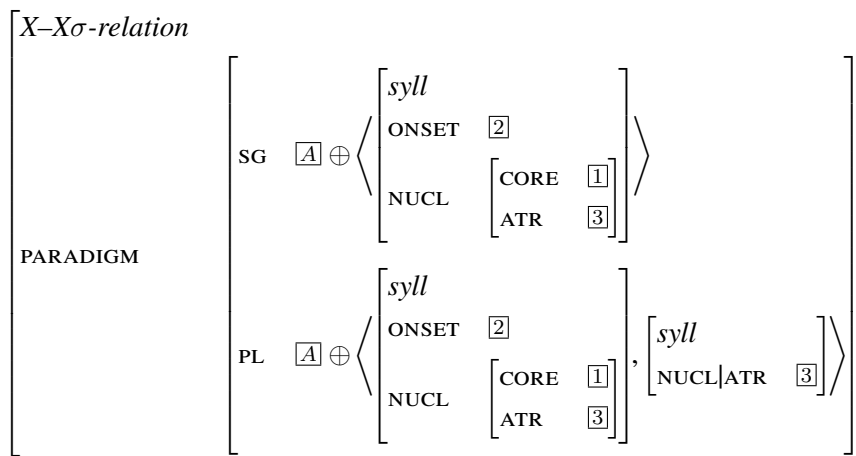

Figure 21: Relation X-X $\sigma$

plural cells are identical.

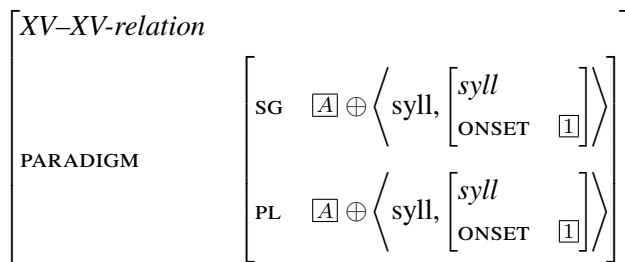

Figure 22: Relation XV-XV

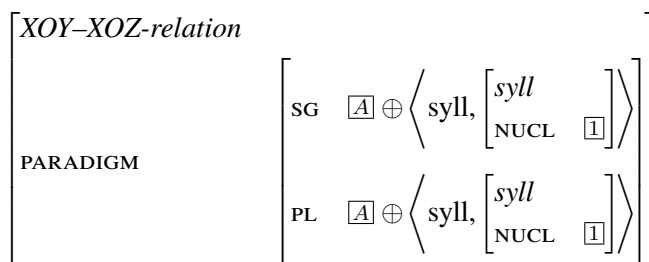

Figure 23: Relation XOY-XOZ

These constraints work together to build full inflectional classes. For example, the singular-plural pair *laanciga-laanci* ('Flapped Lark') instantiates a -g- marker, a singular -A, no non-affixal mutations and the X $\sigma$ -X alternation. The complete structure of *laanciga-laanci* is shown in Figure 25.

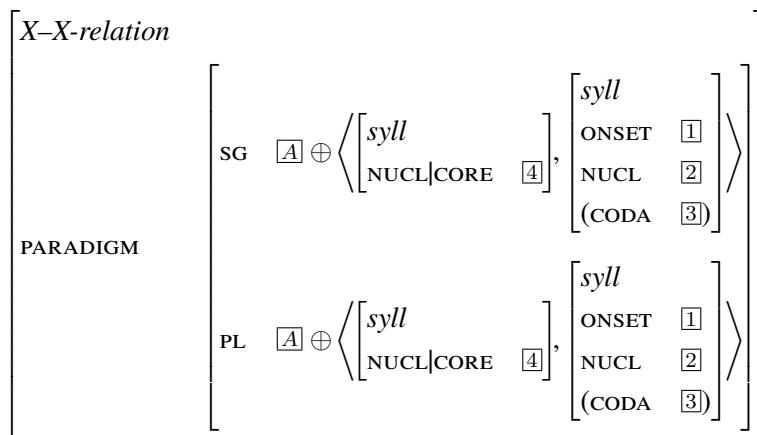

Figure 24: Relation X–X

### 3 Concluding remarks

The system proposed in this paper correctly captures the key aspects of PA approaches and at the same time allows for more abstract generalizations. The main advantage of this formalization over traditional PA models is that we can build complete analogies out of partial analogies, which allows us to express stem alternations without stems, and individual markers without morphemes. The advantage over realizational models like Information based Morphology (Bonami & Crismann, 2015; Crismann & Bonami, 2017) is that, since this system is simpler (it makes fewer assumptions), computational implementation and automatic induction (Beniamine and Guzmán Naranjo forth.) are easier to achieve. Additionally, unlike realizational models, PA models are completely non-directional. In AbM knowing the singular of a noun and its inflection class suffices to deduce its plural form, and vice versa.

This formalization is similar to the string unification approach taken by (Calder, 1989, 1991); however, there are three important differences. First, this approach does not assume that analogies are between strings, strictly speaking, but rather between phonological objects which can have as much structure as needed for the language in question (e.g. syllables, moras, etc.). The second main difference is that this model puts emphasis on being able to express partial analogies and partial descriptions to form complete analogies. Finally, while the system proposed by Calder made use of morphemes and was directional, the present implementation is neither. In the way that AbM is set up, there are no morphemes and no directional relations (at least they are not required).

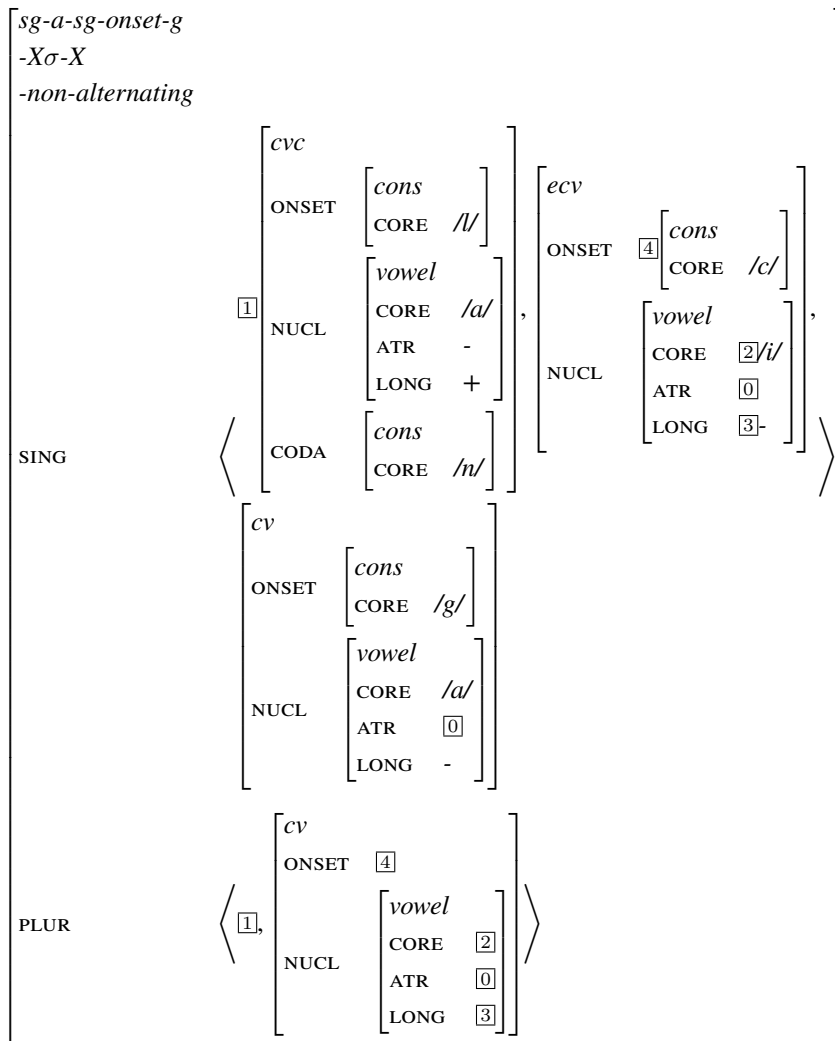

Figure 25: Full analogy for *laanciga*

## References

- Bird, Steven & Ewan Klein. 1994. Phonological analysis in typed feature systems. *Computational linguistics* 20(3). 455–491.
- Blevins, James P. 2006. Word-based morphology. *Journal of Linguistics* 42(3). 531–573.
- Blevins, James P. 2007. Conjugation classes in Estonian. *Linguistica Uralica* 43(4). 250–267.
- Blevins, James P. 2008. Declension classes in Estonian. *Linguistica Uralica* 44(4). 241–267.
- Blevins, James P. 2016. *Word and paradigm morphology*. Oxford, New York: Oxford University Press.
- Bonami, Olivier & Berthold Crismann. 2015. Morphology in Constraint-based lexicalist approaches to grammar. In Andrew Hippisley & Gregory T. Stump (eds.), *Cambridge Handbook of Morphology*, Cambridge: Cambridge University Press.
- Calder, Jonathan. 1989. Paradigmatic morphology. In *Proceedings of the fourth conference on European chapter of the Association for Computational Linguistics*, 58–65. Association for Computational Linguistics.
- Calder, Jonathan. 1991. *An Interpretation of Paradigmatic Morphology*. Edinburgh: University of Edinburgh dissertation.
- Crismann, Berthold & Olivier Bonami. 2017. Atomistic and holistic exponence in information-based morphology. In Stefan Müller (ed.), *Proceedings of the 24th International Conference on oceedings of the 24th International Conference on Head-Driven Phrase Structure Grammar*, 140–160. Stanford, CA: CSLI Publications.
- Guzmán Naranjo, Matías. 2019. *Analogical classification in formal grammar* Empirically Oriented Theoretical Morphology and Syntax. Language Science Press.
- Howard, Irwin. 1969. Kasem nominals revisited. *Working Papers in Linguistics - University of Hawaii* 10.
- Howard, Irwin. 1970. Kasem nominals and the ordering of phonological rules. *Working Papers in Linguistics. University of Hawaii* 2(3). 112.
- Meurers, Walt Detmar, Gerald Penn & Frank Richter. 2002. A Web-based Instructional Platform for Constraint-Based Grammar Formalisms and Parsing. In Dragomir Radev & Chris Brew (eds.), *Effective Tools and Methodologies for*

- Teaching NLP and CL*, 18–25. New Brunswick, NJ: The Association for Computational Linguistics. <http://ling.osu.edu/~dm/papers/ac102.html>. Proceedings of the Workshop held at the 40th Annual Meeting of the Association for Computational Linguistics. 7.–12. July 2002. Philadelphia, PA.
- Monachesi, Paola. 2005. *The verbal complex in Romance: A case study in grammatical interfaces*, vol. 9. Oxford, New York: Oxford University Press.
- Müller, Stefan. 2007. The Grammix CD Rom. a software collection for developing typed feature structure grammars. In Tracy Holloway King & Emily M. Bender (eds.), *Grammar engineering across frameworks 2007 Studies in Computational Linguistics ONLINE*, 259–266. Stanford, CA: CSLI Publications. <http://hpsg.fu-berlin.de/~stefan/Pub/grammix.html>.
- Neuvel, Sylvain. 2001. Pattern analogy vs. word-internal syntactic structure in West - Greenlandic: Towards a functional definition of morphology. In Geert E. Booij & Jaap van Marle (eds.), *Yearbook of Morphology 2000 Yearbook of Morphology*, 253–278. Amsterdam: Springer.
- Niggli, Idda & Urs Niggli. 2007. *Dictionnaire bilingue kasum - français français - kassem*. Burkina Faso: Société Internationale de Linguistique. [kassem-bf.webonary.org/](http://kassem-bf.webonary.org/).
- Penn, Gerald. 2004. Balancing clarity and efficiency in typed feature logic through delaying. In *Proceedings of the 42nd Annual Meeting on Association for Computational Linguistics, main volume*, 239–246. Barcelona, Spain: Association for Computational Linguistics.
- Singh, Rajendra & Alan Ford. 2003. In Praise of Śākaṭāyana: Some Remarks on Whole Word Morphology. In Rajendra Singh, Stanley Starosta & Sylvain Neuvel (eds.), *Explorations in seamless morphology*, 66–76. New Delhi: SAGE.
- Singh, Rajendra, Stanley Starosta & Sylvain Neuvel. 2003. *Explorations in seamless morphology*. New Delhi: SAGE.
- Zaleska, Joanna. 2017. *Coalescence in without coalescence*: Universität Leipzig dissertation.