

**Proceedings of the 10th International Conference on
Head-Driven Phrase Structure Grammar**

Michigan State University

Stefan Müller (Editor)

2003

Stanford, CA: CSLI Publications

The papers are published under a CC-BY license:
<http://creativecommons.org/licenses/by/4.0/>

Contents

Editor's note	4
Anne Abeillé: A lexicon- and construction-based approach to coordinations	5
Anne Abeillé, Danièle Godard: The syntactic flexibility of adverbs: French degree adverbs	26
John Beavers: More heads and less categories: A new look at noun phrase structure	47
Chan Chung, Jong-Bok Kim: Capturing word order asymmetries in English Left-Peripheral Constructions: A Domain-Based Approach	68
Kordula De Kuthy, W. Detmar Meurers: Dealing with optional complements in HPSG-based grammar implementations	88
Kordula De Kuthy, W. Detmar Meurers: The secret life of focus exponents, and what it tells us about fronted verbal projections	97
Dan Flickinger, Francis Bond: A two-rule analysis of measure noun phrases	111
Jeanette Gundel: Information structure and referential givenness/newness: How much belongs in the grammar?	122
Mohammad Haji-Abdolhosseini: A constraint-based approach to information structure and prosody correspondence	143
Anke Holler: An HPSG analysis of the non-integrated <i>wh</i> -relative clauses in German	163
Florian Jaeger: Topics First! In- and outside of Bulgarian <i>wh</i> -interrogatives	181
Andreas Kathol: Cooperating constructions in Lai "lexical insertion"	203
Jean-Pierre Koenig, Anthony Davis: Semantically transparent linking in HPSG	222
Robert D. Levine, Ivan A. Sag: Some empirical issues in the grammar of extraction	236
Roger Levy, David Yoshikazu Oshima: Non-transitive information flow in Japanese noun-classifier matching	257

Stefan Müller: Object-to-subject-raising and lexical rule: An analysis of the German passive	278
Luis Paris, Jean-Pierre Koenig: What does it mean to be a complement?	298
Gerald Penn, Kenneth Hoetmer: In search of epistemic primitives in the English Resource Grammar (or Why HPSG can't live without higher-order datatypes)	318
Matthew Purver, Jonathan Ginzburg: Clarifying noun phrase semantics in HPSG	338
Jeffrey T. Runner, Raul Aranovich: Noun incorporation and rule interaction in the lexicon	359
David Schlangen, Alex Lascarides: A compositional and constraint-based approach to non-sentential utterances	380
Frank Van Eynde: On the notion "determiner"	391
Eun-Jung Yoo: Specificational pseudoclefts in English	397

Editor's note

The 10th International Conference on Head-driven Phrase Structure Grammar was held at Michigan State University, Michigan in the USA.

The conference featured three invited talks, 26 papers, and two alternate papers, selected by the program committee (Bob Borsley, chair, Doug Arnold, Elisabeth Engdahl, Erhard Hinrichs, Tom Hukari, Andreas Kathol, Jean-Pierre Koenig, Shalom Lappin, Detmar Meurers, Tsuneko Nakazawa, Adam Przepiórkowski, Ivan Sag, Gert Webelhuth, Shûichi Yatabe) with the help of additional reviewers (Ronnie Cann, Danièle Godard, Georgia Green, Jeanette Gundel, Caroline Heycock, Ewan Klein, Stefan Müller, Frank Richter, Manfred Sailer, Andrew Spencer). In total there were 42 submissions. We want to thank the program committee and the external reviewers for putting this nice conference program together.

Thanks go to Ivan Sag and Gert Webelhuth, who were in charge of local arrangements. I also want to thank Ivan Sag for help regarding computational infrastructure in Stanford.

As was decided on the Business Meeting I will take care of editing the HPSG proceedings from now on, in order to guarantee fast publication of the conference results to make the work presented at the conference available to a wider audience. As in the past years the contributions to the conference proceedings are based on the five page abstract that was reviewed by the program committee, but there is no additional reviewing of the longer contribution to the proceedings. To ensure easy access and fast publication we have chosen an electronic format.

The proceedings include all the papers except those by Olivier Bonami and Danièle Godard, Gosse Bouma, Incheol Choi and Stephen Wechsler, Robert Malouf, Vanessa Metcalf, Peter Sells, and Kei Yoshimoto and Masahiro Kobayashi.

A lexicon- and construction-based approach to coordinations

Anne Abeillé 

Universite Paris 7

Proceedings of the 10th International Conference on
Head-Driven Phrase Structure Grammar

Michigan State University

Stefan Müller (Editor)

2003

Stanford, CA: CSLI Publications

pages 5–25

Abeillé, Anne. 2003. A lexicon- and construction-based approach to coordinations. In Stefan Müller (ed.), *Proceedings of the 10th International Conference on Head-Driven Phrase Structure Grammar, Michigan State University*, 5–25. Stanford, CA: CSLI Publications. DOI: 10.21248/hpsg.2003.1. 

Abstract

Leaving aside elliptical coordinations, it is striking that no agreement has been reached on the structure of basic coordinate constructions. We propose that:

- coordinate constructions are structurally asymmetric : the conjunction makes a subconstituent with one of the conjuncts.
- such constituents can have several functions: coordinate daughter, adjunct daughter or main clause.

In order to show that some conjuncts should be analysed as adjuncts, we focus on asymmetric cases of coordination, in which the order of the conjuncts cannot be reversed, taking examples from French, Welsh and Korean.

We present an HPSG analysis which treats the "coordinating" conjunctions as "weak" heads, with lexical subtypes, and coordinate phrases as multi-headed constructions, with different subtypes.

Introduction¹

Most recent work on the syntax of coordination in HPSG (e.g. Levy and Pollard 2001, Sag 2002), and LFG (Dalrymple & Kaplan 2000), has been devoted to feature passing and feature resolution, while most has been devoted to the structure of coordinated phrases in derivational approaches (Munn 1992, Johanessen 1998). Leaving aside elliptical coordinations, it is striking that no agreement has been reached on the structure of basic coordinate constructions. We propose that:

- coordinate constructions are structurally asymmetric : the conjunction makes a subconstituent with one of the conjuncts.
- this *Conj X* constituent can have several functions, including adjunct.

We first discuss the basic structures which have been proposed, and then focus on asymmetric "coordinations", in which the order of the conjuncts cannot be reversed, taking examples from French, Welsh and Korean, and show that they are best analysed as adjuncts.

We then provide an HPSG analysis for French "coordinating" conjunctions and for the different constructions involving phrases introduced by such conjunctions.

1. Different structures proposed for coordination

The syntactic analysis of coordinate phrases has often been debated. We distinguish two independent questions:

- is the structure hierarchical (A) or flat (B) ?
- do the daughters have the same function or not ?

¹ Many thanks to Bob Borsley, Danièle Godard, Liliane Tasmowski, for fruitful discussions, and to the Paris 7 reading group on coordination especially François Mouret, Jesse Tseng and Olivier Bonami.

Let us start with the structural issue. Some versions of A is adopted in Sag et al 1985, Johannessen 1998 a.o, while B is used in Dalrymple and Kaplan 2000, Sag and Wasow 1999, a.o.

Hierarchical structure (A) Flat structure (B)

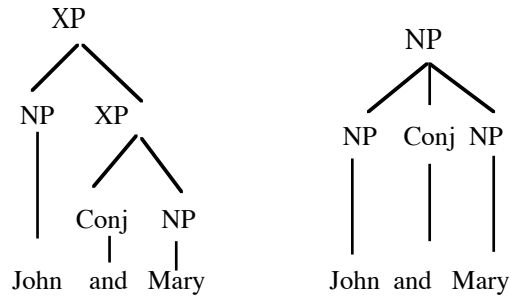

As observed by Ross (1967), Munn (1992) a.o., the main problem with flat structure B is that it ignores the fact that Conj-XP combinations are well-formed phrases outside coordinations (cf Huddleston and Pullum 2002):

- (1) a And Mary ?
b Nor do the French
- (2) a John bought a book yesterday, and a newspaper
b They allowed the others a second chance, but not me
c Did the boss tell you that or her secretary ?

Structure B also cannot account for break asymmetry (cf Ross 1967):

- (3) a I will see John # and Mary
b * I will see John and # Mary

Third, there are languages where the conjunction is an affix on one of the conjuncts (cf (5) below, and Borsley 1994). We thus conclude that the conjunction forms a subconstituent with one of the conjuncts (cf Ross 1967, Sag et al 1985, Borsley 1994, Munn 1992...), and that structure B has to be rejected.

Let us now consider the functional issue. Symmetric analyses, such as (1), assign the same function to all conjuncts, while asymmetric ones (2 and 3) identify one of the conjuncts as the head.

- 1- head-head 2- spec -head-complement 3- head-adjunct
 Sag et al 1985, Kayne 1994 Munn 1992, 2000
 Gazdar et al 1985 Johannessen 1999

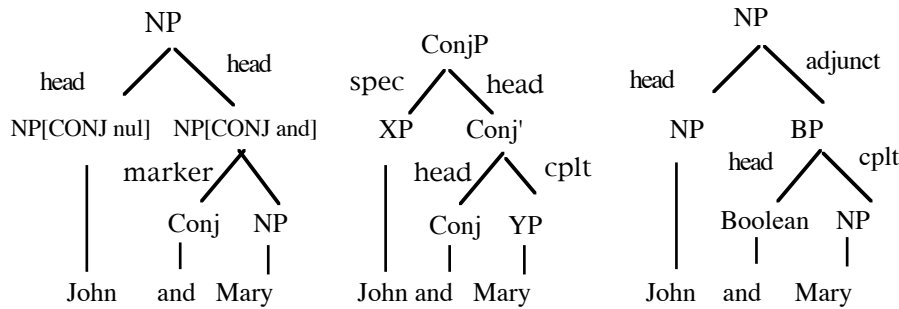

Starting with symmetric analyses, Sag et al (1985) have proposed, within GPSG, that all conjuncts be heads. This provides a straightforward account for syntactic feature sharing between the conjuncts (and ATB extraction), as well as an analysis of unlike coordination such as (4a) since Head features are intersected and the resulting phrase can be underspecified:

- (4) a John is a Republican and proud of it
 b What did John run to the store and buy ?

But it makes it difficult to account for asymmetric conjuncts, as in (4b). For violations of ATB constraints, Sag et al posit a special rule coordinating V and VP in English, and other asymmetries (such as inflection or case marking on only one conjunct) would require more schemata. So this approach is only well suited for symmetric coordination (where the conjuncts can be unlike but the order between them can be reversed).

Adopting the opposite view, Pollard and Sag (1994), Sag and Wasow (1999) have assumed that coordinate phrases are the only non-headed types of phrases. This is meant to capture the fact that some features (eg number for NPs) are specific to the coordinate phrase, but for all other features this leads to adding sharing constraints between the phrase and the conjuncts, as well as between the conjuncts. On the other hand, if one views the Generalized Head feature principle as imposing default unification of Synsem values (as in Ginzburg et Sag 2000), one could benefit from default unification for distributive features (such as MOD, COMPS or PRED), and add specific values (associated with a coordinate type of phrase) only when needed.

Let us now turn to asymmetric approaches, that identify only one conjunct as the head. Reductionist approaches (Kayne 1994, Johannessen 1998) reduce

coordinate structures to X-bar schemata, with the Conjunction as the head, the first Conjunct as the Specifier and the second one as the Complement (cf also Paritong 1992 for an HPSG version). As pointed out by Borsley (1994), (2002), this type of analysis faces several syntactic problems : first, it is not expected that a phrase behaves like its specifier (=NP, PP etc). Second, if the marked conjunct is the syntactic head of the whole coordinated phrase, it should appear last in strictly head-final languages such as Japanese or Korean, contrary to fact (5a,b).

- (5) a hon-to pen (Japanese)
 book-and pen
 b Sunwoo-wa Hiyon (Korean)
 Sunwoo-and Hiyon

Third, it does not extend to n-ary coordinations : if the unmarked conjunct is analysed as a specifier, one expects only one specifier per phrase. If one alternatively tries to analyse ternary coordinations as embedded binary coordinations (with an empty first conjunction), one does not see how to prevent them from being introduced by *both*, *either* etc (cf Borsley 2002):

- (6) a John, Bob and Mary
 b * Both John, Bob and Mary

Munn (1992, 2000) has proposed that the conjunction heads a Boolean phrase that is adjoined to the other conjunct. This accounts for cross-linguistic word order variation (the unmarked conjunct is the head), but not for feature sharing between the conjuncts. It does not extend to n-ary coordinations, nor to coordinations with multiple conjunctions.

Our proposal is that both structures (1) and a revision of (3) are needed. Structure 1 accounts for n-ary coordinations, and for coordinations with multiple conjunctions. Structure 3 accounts for asymmetric coordinations such as Russian comitative coordination, where the case of the NP is that of the first conjunct (cf Mac Nally 1994):

- (7) a Anna s Petej pridut
 Anna-nom with Peter-instr are-coming-plur
 b * Petej s Anna pridut

If some "conjuncts" as in (7a) are to be analysed as adjuncts, the only revision needed with structure (3) is that the category of the adjunct should vary with

its complement (NP, PP...). We first provide more cases of such "adjoined" conjuncts, before turning to our HPSG analysis.

2. Some conjuncts as adjuncts

We first present some French data, then turn to some cases of verbal coordinations in Welsh and Korean.

French coordination involves 4 basic coordinating conjunctions : *et* (and), *ou* (or), *mais* (but), *ni* (nor). We first consider *car* (since), which interestingly shares some properties with coordinating conjunctions and others with synonymous subordinators such as *puisque* (since) or *parce que* (because), and then turn to incidental coordinations introduced by the basic conjunctions.

2.1. French CAR

Car is used to introduce finite clauses, with a causal meaning:

- (8) Paul est parti *car* il pleuvait
Paul has gone since it was raining

A traditional debate in French grammars is to determine whether *car* is a coordinating or a subordinating conjunction. We think it is necessary to distinguish the lexical properties of *car* from the syntactic properties of the phrase it introduces.

First, *car* shares some properties with coordinating conjunctions. Like other conjuncts, *car* phrases cannot be conjoined, while subordinate clauses introduced by a preposition or a complementizer can:

- (9) a Jean est parti *parce qu'il* pleuvait *et parce que* Marie était là.
Jean has gone because it was raining and because Marie was there
b * Jean est parti *car* il pleuvait *et car* Marie était là.
Jean has gone since it was raining and since Marie was there

Unlike subordinating conjunctions, *car* cannot be replaced by *que* in the second conjunct, when one coordinates two S's under *car*:

- (10) a Paul n'est pas venu *car* il pleuvait *et* il faisait froid.
Paul didn't come since it was raining and it was cold
b * Paul n'est pas venu *car* il pleuvait *et qu'il* faisait froid.
c Paul n'est pas venu *puisque* il pleuvait *et qu'* il faisait froid.
d Paul n'est pas venu *comme* il pleuvait *et qu'il* faisait froid.

Car cannot occur initially, differently from synonymous complementizers (*puisque S*):

- (11) a * *Car* il pleuvait, Paul n'est pas sorti.
Since it was raining Paul has not gone out
b *Puisqu'il* pleuvait, Paul n'est pas sorti.

The *car S* can behave as a main clause : clitic subject inversion is possible (cf Wilmet 1997):

- (12) a Paul est parti *car* avait-il le choix ?
Paul has gone since did he have the choice ?
b Paul est parti *car* peut-être voulait-il voir Marie.
Paul has gone since maybe did he want to see Marie

So the *car S* is not necessarily a subordinate clause, but is it a coordinate clause ? Like other clauses introduced by *puisque* or *bien que*, the *car* phrase must be an S or a predicative phrase (which can be analysed as a reduced clause):

- (13) a Jean est fonctionnaire [*car/ puisque* professeur]NP
Jean is civil servant since teacher
b Jean est heureux [*car* bien portant]AP
Jean is happy since healthy
c Jean est heureux [*bien que* malade]AP
Jean is happy although sick

Unlike coordinate phrases, *car* phrases cannot be non finite VPs nor lexical conjuncts:

- (14) a *Jean veut venir *car/ puisque* voir Marie
Jean wants to come since see Marie
b Jean veut venir et /ou voir Marie.
Jean wants to come and/or see Marie
c Jean lit [*et / *car* traduit]V Proust
Jean reads and/since translates Proust
d *Les soldats [*car / puisque* officiers]N
The soldiers since officers
e Les soldats et officiers.
The soldiers and officers

A shared subject cannot be omitted in *car* phrases, unlike what we find in coordinate clauses :

- (15) a Jean est venu et (il) a vu Marie.
Jean has come and (he) has seen Marie

- b Jean est venu car *(il) a vu Marie.
- c Jean est venu parce qu' *(il) a vu Marie.
Jean has come since he has seen Marie

In (15b), like in the adjunct clause (15c), the subject 'il' cannot be omitted, while it can in a coordinate clause like (15a). The same contrast holds for gapping, and the *car* clause does not behave like a coordinate clause:

- (16) a Jean vend des chaises et Marie des tables
Jean sells chairs and Marie tables
- b Jean vend des chaises car Marie *(vend) des tables.
Jean sells chairs since Marie sells tables
- c Jean vend des chaises puisque Marie *(vend) des tables.

Crucially, the *car* phrase does not obey the Coordinate Structure Constraint : one can extract out of the main clause, without extracting out of the *car* clause (17a). Moreover, no parasitic gap is allowed in the *car* clause (parasitic gaps are disallowed in finite adjunct clauses in French):

- (17) a le parapluie que j'ai pris car il pleuvait
the umbrella that I took \emptyset since it was raining
- b *le parapluie que j'ai pris car Paul m'avait offert
the umbrella that I took \emptyset since Paul offered me \emptyset
- c * le parapluie que j'ai pris parce que Paul m'avait offert

Our conclusion is that *car* is a coordinating conjunction (CC), which explains why it cannot be preceded by another CC, and why the *car* phrase cannot be initial. But instead of introducing a coordinate phrase, it introduces an adjunct phrase, which explains why it is an island for extraction. This adjunct phrase is not a subordinate clause (it does not trigger *que* coordination, it allows clitic inversion).

Turning now to incidental coordinations, we show that this apparently idiosyncratic behaviour of *car* is not exceptional, and that all coordinating conjunctions can introduce adjunct phrases in French.

2.2. Incidental coordinations

Incidental coordinations (i.e. coordinations with an incidental prosody) are of the form: *S Conj XP*.

- (18) John read the book (and) avidly.

Progovac 1998 has provided an analysis in terms of unlike coordination between VP and XP (with a possibly empty conjunction). This analysis does

not predict that the order of "conjuncts" cannot be reversed, nor that extraction is allowed out of the first "conjunct" :

- (19) a * John avidly and read the book.
 b The book that John read, and avidly.

Focussing on French, Marandin (1998) has shown that such *Conj XPs* have a special intonation, and the same mobility as incidental adverbs (except S initial position):

- (20) a Jean, et c'est heureux, a lu votre livre
 Jean, and it is fortunate, has read your book
 b Jean a, et c'est heureux, lu votre livre
 c Jean a lu, et c'est heureux, votre livre
 d Jean a lu votre livre, et c'est heureux

- (21) a Jean a, mais trop tard, lu votre livre
 Jean has , but too late, has read your book
 b Jean a lu, mais trop tard, votre livre
 c Jean a lu votre livre, mais trop tard

- (22) a Jean, ou bien Marie, lira votre livre
 Jean, or else Marie, will read your book
 b Jean lira, ou bien Marie, votre livre
 c Jean lira votre livre, ou bien Marie

- (23) a Heureusement, Paul a lu votre livre
 Fortunately, Jean has read your book
 b * Et c'est heureux, Jean a lu votre livre
 c * Ou je me trompe, Jean a lu votre livre
 d * Mais trop tard, Jean a lu votre livre

We show that these constructions do not involve coordinations. Such incidental conjuncts can be of various categories: NPs, PPs, Ss... They cannot be analysed as extraposed from an NP or PP coordination. The agreement pattern is different from that of NP coordinations. In French, *ou* triggers singular or plural agreement, but when the 'ou NP' is incidental, only the singular is allowed (cf 22); *et* triggers plural agreement, but not with incidental *et NP*:

- (24) a Jean ou Marie lira / liront votre livre.
 Jean or Marie will-read-sg / plur your book
 b Jean lira /* liront votre livre, et Marie aussi
 Jean will-read-sg your book, and Marie too.
 c Jean et Marie liront /*lira votre livre.

An alternative analysis would be to analyse these constructions as S (or VP) coordinations, with the incidental conjunct being a reduced S (or VP). It is true that semantically the incidental conjunct is interpreted as a parenthetical clause. But a reduced S (or VP) analysis fails on syntactic grounds, because extraction can involve only the main clause and not the incidental conjunct:

- (25) a un livre que Jean a lu à ses enfants, et c'est heureux.
 a book that Jean has read to his children, and it is fortunate
 b un enfant dont le père viendra, ou bien Marie
 a child of which the father will come, or else Marie

This violation of the CSC would be odd if the incidental conjunct was a coordinated S (or VP). The facts follow if it is analysed as an adjunct: like other adjuncts, it is mobile, and it is an island for extraction.²

Our conclusion is that incidental conjuncts are syntactic adjuncts. They can be of any (phrasal) category, provided that have the semantic type: proposition.³

Let us now turn to two other languages, which also have "conjuncts" syntactically behaving as adjuncts.

2.3 Welsh serial coordination

Welsh serial coordination is characterised by the following properties (cf Rouveret 1994, Sadler 2003): Tense is marked only on the first conjunct, the others involve "verbal nouns"; the order of the conjuncts is fixed (and usually indicative of narrative progression); the subject is shared between the conjuncts (examples from Rouveret):

- (26) a Aethant i'r ty ac eistedd a bwyta
 go-past-pl to the house and sit-VN and eat-VN
 They went to the house and sat and ate
 b Aeth y ffermwr at y drws a churo arno
 Go-past-sg the farmer to the door and knock-VN on-it
 The farmer went to the door and knocked on it

Rouveret analyses such cases as asymmetric TP coordination: the tensed V moves to Agr, the untensed VP adjoins to the first VP (which has an empty

² Only parasitic gaps are allowed as in:

(i) un livre dont l'auteur viendra, ou l'éditeur
 a book of-which the author will-come, or the publisher

³ The same facts hold for English, assuming 'but John' is incidental:

a Noone but John was /*were here.
 b A man that no friends of, but John, will admire
 c *A man that John, but no friends of, will admire

Tense but a full subject). Sadler 2003, working in LFG, proposes an analysis in terms of unlike coordination with a flat structure :

IP -> IP (Conj VP)⁺
 □ □ ↑ □ = ↑ □ □ ↑
 □ tense = ↑tense
 □SUBJ = ↑SUBJ

Tense and Subject of the first conjunct are shared with the other conjuncts at f-structure. Such an analysis, based on unlike coordination, has to stipulate that the order of conjuncts cannot be reversed. It also has to stipulate that the conjunction has to be repeated on each untensed VP (whereas ternary coordination usually allow sequences with only the last conjunct marked). Without going into the details of the construction, we follow Rouveret in that such constructions do not involve coordination. We propose that the untensed conjunct is adjoined to the first clause, which we analyse as the head. An important argument (given by Sadler 2003) is that such constructions do not obey the CSC : one can extract out of the tensed conjunct without extracting out of the other conjuncts:

- (27) I'r ty yr aethant ac eistedd a bwyta
 to the house PT go-past-pl and sit-VN and eat-VN
 It's to the house that they went and sat and ate

Another argument is that, since Welsh is a head initial language, we predict that the untensed VP must follow the tensed one which is the head. We also analyse apparent ternary examples like (26a) as iterated adjunctions: it follows that the conjunction has to be repeated on each untensed conjunct. Since *ac* is also used for plain symmetric coordinations, we take Welsh serial "coordination" as another argument that "coordinating" conjunctions can introduce adjuncts.

2.4 Korean VP coordinations

S or VP coordination in Korean uses the suffix *-ko* on the first conjunct. Such coordinations can be symmetric, as in (28a) or asymmetric as in (28b) where the first conjunct is untensed (cf Choi 1999, Kim 2000):

- (28) a Kim-un wain-ul masi-ess-ko Lee-ka maykcwu-lul masi-ess-ta
 Kim-top wine-acc drink-past-conj Lee-nom beer-acc drink-past-decl
 Kim drank wine and Lee drank beer
 b Kim-un wain-ul masi-ko Lee-ka maykcwu-lul masi-ess-ta
 Kim-top wine-acc drink-∅-conj Lee-nom beer-acc drink-past-decl

As shown by Choi 1999, the meaning is slightly different : in (28a) we have two different events, in (28b) there is a particular relationship (causal or temporal) between the two events that make up one event.

Tense marking cannot be considered as optional in the first conjunct. As shown by Kim (2000), the syntactic properties are different. The first conjunct is mobile when it is untensed, and not when it is tensed. In (29a) the untensed conjunct occurs between the subject and the object, while in (29b) the first tensed conjunct cannot:

- (29) a Kim-un [Lee-ka ttena-ko] ungun g wulessta
 Kim-top Lee-nom leave-conj eyes-out cry-past-decl
 Kim cried his eyes out since/because Lee left
 b * Kim-un [Lee-ka ttenass-ko] ungun g wulessta
 Kim-top Lee-nom leave-past-conj eyes-out cry-past-decl

Crucially, coordination of two tensed clauses obey the Coordinate Structure Constraint, while coordination with an untensed clause does not. In (30a), one can extract out of the tensed clause, without extracting out of the untensed clause (examples from Kim 2000):

- (30) a Mwues-ul John-i [pap-ul mek-ko] thakcawi-ey noh-ass-ni ?
 what-acc John-nom meal-acc eat-conj table-loc put-past-quest
 What did John put on the table and eat the meal ?
 b * Mwues-ul John-i [pap-ul mek-ess-ko] thakcawi-ey noh-ass-ni ?
 what-acc John-nom meal-acc eat-past-conj table-loc put-past-quest

Kim's conclusion, which we share, is that the untensed conjunct is an adjunct clause. As Korean is a head final language, it is predicted that it must precede the tensed main Verb. So a ko-marked clause can behave as a coordinate phrase or as an adjunct phrase.

3. Representation within HPSG

We now show how the two sides of our analysis can be represented within HPSG:

- the conjunction forms a subconstituent with one of the conjuncts (first or last depending on the language),
- such a constituent can have several functions (coordinate daughter or adjunct daughter).

3.1. The conjunction as a weak head

Since the conjunction tends to follow its conjunct in head-final languages and to precede it in head-initial languages, it can be a marker (as in Sag et al 1985) or a head. Recent HPSG research tends to reanalyse most markers as

heads (Sag 1997, Tseng 2001). Since the conjunction is semantically potent, it is difficult to analyse it as a marker. Moreover, the conjunct following the conjunction can be marked and this information must be passed up on the phrase made by the conjunction and the conjunct. For example in French, NPs can be marked by DE or unmarked, and this information must be shared between two coordinated NPs.

We thus analyse the conjunction as a head, but as a "weak" head, sharing most of its syntactic features with its complement. We propose that conjunctions take (at least) one complement and inherits most syntactic features from it, except for the lexical feature CONJ which is specific for each conjunction.

(31) Schematic entry for Coordinating Conjunctions :⁴

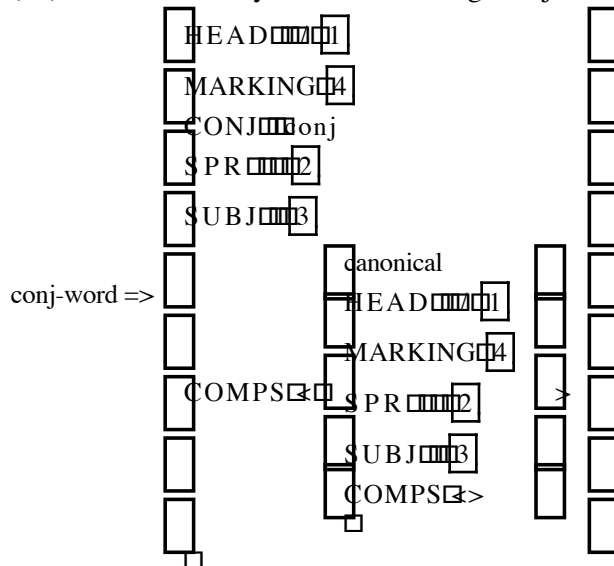

As a result, conjunctions can head phrases with different categories, as in the following trees:⁵

⁴ '/' means default sharing. We ignore lexical coordination here. To account for it, one would need to underspecify the COMPS value of the complement and have the conjunction inherit it.

⁵ The weak Head analysis (head with an underspecified category) is also used for French "de" which introduces phrases of various categories (Abeillé et al 2003):

- a quelquechose [de [beau]AP]AP something beautiful
- b Paul promet [de [venir]VP]VP Paul promises to come
- c Personne ne veut [de [problèmes]N]N Nobody wants troubles

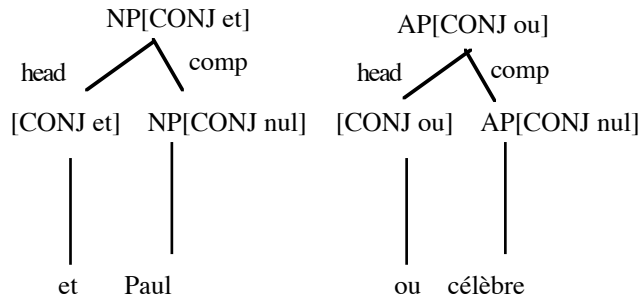

The type *canonical* on the complement of the conjunction prevents extraction such as the following:

(32) * What did you see a picture of and ?

As in Gazdar et al 1985, we use a CONJ feature which distinguishes the complement from the conjunct phrase, and prevents the conjunct phrase from being an argument. We posit a general constraint on words:⁶

(33) word => ARG-ST list([CONJ nil])

Notice that this prevents the conjunct phrase from being the complement of another conjunction. The ban on stacking conjunctions (**et ou* , **mais et* ...) is thus provided at no cost.

The conjunct phrase cannot be subject nor complement, but can have several functions :

- coordinate daughter: Jean et Marie (Jean and Marie)
- adjunct daughter: Jean viendra, ou Marie (Jean will come, or Mary)
- main clause Et il est parti ! (And he's gone)

3.2. Coordinate phrases

For coordinate constructions, we define coordinate phrases as multi-headed, with at least one CONJ marked daughter (nelist means 'non empty list'):

coord-phr => [CONJ nil] [HD-DTRS nelist([CONJ nil]) nelist([CONJ nil]) nelist([CONJ nil])]

We rely on a Precedence rule that orders marked conjuncts last:

⁶ (33) is not necessarily a universal constraint. In Slavic languages, such as Russian or Czech, the AND conjunction (i) can mark a subject or a complement and is interpreted as a focus marker (=even).

(37) Hierarchies for features PER and GEN:

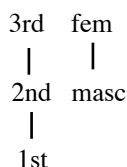

For French, different subtypes of coordinated phrases are needed, based on headedness (NP or not) and on arity (depending on the conjunction).⁷ We distinguish binary phrases (with the conjunctions *mais* or *ni*), and n-ary phrases (with *et* or *ou*):

- (38) bi-coord-phrase => DTRS <[CONJ nil], [CONJ mais/ ni]>
n-ary-coord-phrase => DTRS <...[CONJ et/ou]>

We thus exclude examples such as the following:

- (39) a ?? Jean est riche, célèbre mais malheureux.
Jean is rich, famous, but unhappy
b * Jean est riche, mais célèbre mais malheureux.

3.3. Representation of French *car*

As shown above, we say that *car* is a conjunction (with a [CONJ *car*] feature), takes a (main) S (indicative) or [PRED +] complement, which is an island for extraction (SLASH {}), and has a [MOD V] feature (that forces the *car* phrase to be used as an adjunct). The lexical entry for *car* is thus as follows:

(40) Lexical entry for *car*:

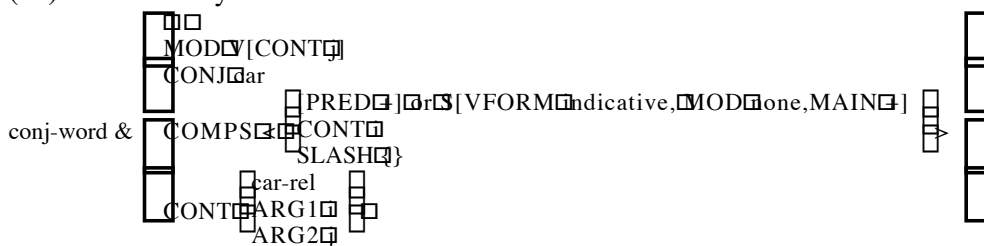

We use the standard head-adjunct phrase, and the same LP rule as for coordinate phrases (a CONJ marked phrase must be final):

⁷ More subtypes may be needed in order to account for the specificities of lexical coordinations, as well as coordination with multiple conjunctions.

(41) hd-adj-phrase => [CONJ nil] < [CONJ ≠nil]

Notice that *car* clauses cannot be coordinate daughters because their MOD feature would conflict with that of the first conjunct (assuming finite Ss are [MOD none]).

3.4. Incidental conjuncts

We represent incidentals as adjuncts with a boolean Head INCIDENT feature, as in Bonami and Godard 2003. We analyse incidental conjuncts as V adjuncts, which enter into Head-adjunct-phrases or Head-complements-adjuncts-phrases:

(42) Head-Comps-Adj Phrase:

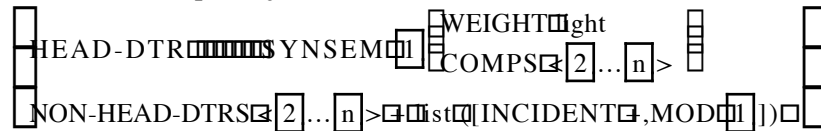

Ordering of incidental adjuncts is free in the hd-comp-adj-phrase and constrained by (41) in the hd-adj-phrase.⁸

For incidental conjunct phrases, we define a subtype of conjunction word, with the appropriate features. We thus have two subtypes of conj-words : basic-conj-word and discourse-conj-word.

Basic-conj-word are marked as [INCIDENT -] and share (by default) the INCIDENT value of their complement. They also inherit the MOD value of their complement.⁹ Discourse-conj-word have a specific [MOD V] feature, which they do not necessarily share with their complement, and an [INCIDENT +] feature, which their complement does not have. Semantically, discourse conjunctions are binary relations and take the phrase they modify as one of their arguments. They force their complement to be interpreted as a proposition.

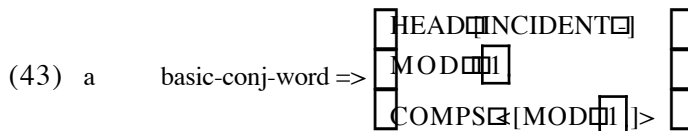

⁸ Bonami and Godard deal with incidental adverbs, using a specific binary incidental-adjunct-phrase and domain union for linearization.

⁹ As in Sag and Wasow 1999, we consider MOD as a VAL feature, and not a HEAD feature.

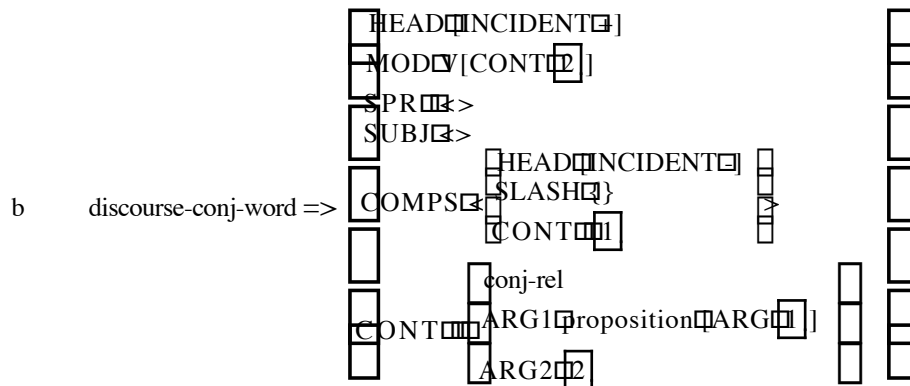

For incidental conjuncts, we thus have representations like the following:

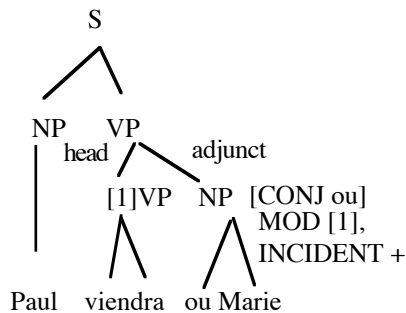

Interestingly, the same lexical entries can be used for conjuncts as main clauses (or discourse conjuncts), to which we now turn.

3.5. Conjuncts as main clauses

Main clause conjuncts can be either full clauses or fragments:

- (44) a Mais Paul est parti! But Paul is gone !
 b Et Paul ? And Paul ?

They can denote questions, propositions or exclamations ("messages" in Ginzburg and Sag 2000). We analyse such conjuncts as clauses inheriting from the head-only phrase. They involve the same lexical entry for conjunctions as incidental conjuncts. The conjunction takes two semantic arguments: its complement (interpreted as a proposition), and another clause available in the discourse context. So we identify the denotation of the MOD value of the conjunct phrase with that of the Context. We thus have the following (simplified) subtype of construction :

(45) Unary-conj-phr =>

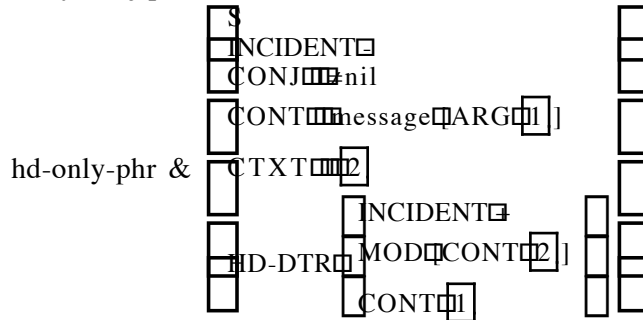

Message is the denotation of a clause (= proposition, question, fact .. cf Ginzburg & Sag 2000) and the second semantic argument of the conjunction is provided by the Context. The [CONJ] feature of the conjunction is passed from the Head Daughter to the Mother, and prevents such clauses from being used as subcategorized arguments.

A (simplified) classification of constructions involving a conjunct phrase in French is thus the following:

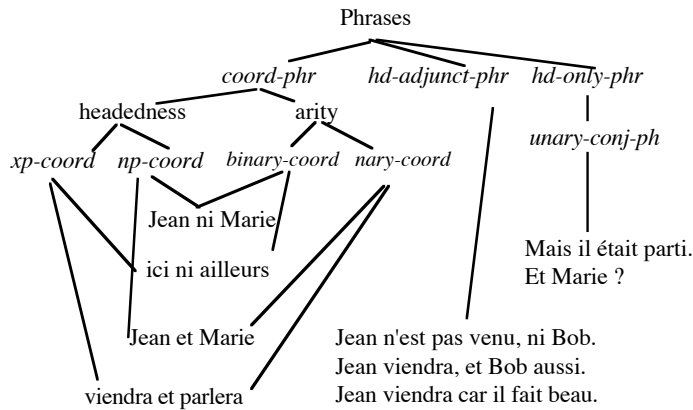

Conclusion

On the basis of data from French, Welsh and Korean, we have proposed to:

- distinguish Conjunction as a type of word and Coordination as a type of construction,
 - analyse Conjunctions as weak syntactic heads, yielding a Conjunct phrase
 - analyse incidental conjuncts and some asymmetric conjuncts as adjuncts.
- We have shown how Conjunct phrases can enter into several constructions (head-only-phrases, head-adjunct-phrases and coord-phrases).

References

- A. Abeillé, O Bonami, D Godard, J Tseng 2003, The syntax of French *à* and *de*, ACL-SIGSEM Workshop on Prepositions, Toulouse
- O. Bonami, D Godard, 2003. Incidental adverbs : an overlooked type of adjunction, HPSG Conference, East Lansing, Michigan.
- R. Borsley 1994. In defense of coordinate structures, *Linguistic Analysis*, 24-3-4, 218-246.
- R. Borsley 2002. Against ConjP, *Lingua*.
- H-W. Choi 1999. *Optimizing structure in context*, Stanford: CSLI Publications.
- M. Dalrymple, R. Kaplan 2000. Feature indeterminacy and feature resolution, *Language*, 76(4), 759-798.
- G. Gazdar, E. Klein, G. Pullum, I. Sag 1985. *Generalized Phrase structure Grammar*, Oxford, Basil Blackwell.
- J Ginzburg, I Sag 2000. *Interrogative investigations: the form, meaning and use of English interrogatives*, Stanford: CSLI Publications.
- R. Huddleston, G. Pullum 2002. *The Cambridge grammar of English*, Cambridge: Cambridge University Press.
- J-B. Johannessen 1998. *Coordination*, Oxford: Oxford U. Press.
- R. Kayne 1994. *The antisymmetry of syntax*, Cambridge: MIT Press.
- J-B. Kim 2000 *The grammar of negation, A constraint based approach*, Stanford: CSLI Publications.
- R Levy, C Pollard, 2001. Coordination and neutralization in HPSG, HPSG Conference, CSLI Publications.
- L. MacNally 1994. Comitative coordination: A case study in group formation, *Natural language and Linguistic Theory*. 11:347-379.
- J-M. Marandin 1998. Grammaire de l'incidence, ms, LLF, Université Paris 7.
- A. Munn 1992. A null operator analysis of ATB gaps, *Linguistic Review*, 9, 1-26.
- A. Munn 2000. Three types of coordination asymmetries, in K. Schwabe, N. Zhang (eds) *Ellipsis in Conjunction*, Tübingen: Max Niemeyer Verlag. 1-22.
- M. Paritong 1992 Constituent coordination in HPSG, in G Görz (ed) *Konvens*, Springer verlag
- C. Pollard, I. Sag 1994. *Head-driven Phrase structure grammar*, Chicago Press.
- L. Progovac 1998. Avoid conjunction reduction, and coordination of likes constraint, *Formal approaches to Slavic linguistics*, Michigan Slavic Publications, 252-266.
- J. Ross 1967. Constraints on variable in syntax, MIT Phd Thesis.
- A. Rouveret 1994. *Syntaxe du gallois: Principes généraux et typologie*, Paris: CNRS Editions.

- L. Sadler 2003. Tense concord in coordination, Conference on Celtic Languages, King's college.
- I. Sag, G Gazdar, T Wasow, S Weisler 1985. Coordination and how to distinguish categories, *Natural Language and Linguistic Theory*, 3, 117-171.
- I. Sag 1997. English relative clause constructions, *Journal of linguistics*, 33: 431-484
- I. Sag, T Wasow 1999. *Syntactic theory : a formal introduction*, Stanford: CSLI Publications.
- I. Sag 2002. Coordination and underspecification, HPSG Conference, Seoul.
- J. Tseng 2001 Remarks on marking, HPSG Conference, Trondheim.
- M. Wilmet 1997. *Grammaire critique du français*, Paris:Hachette Université.

The syntactic flexibility of adverbs: French degree adverbs

Anne Abeillé 

Université Paris 7

Danièle Godard 

LLF, CNRS

Proceedings of the 10th International Conference on
Head-Driven Phrase Structure Grammar

Michigan State University

Stefan Müller (Editor)

2003

Stanford, CA: CSLI Publications

pages 26–46

Abeillé, Anne & Danièle Godard. 2003. The syntactic flexibility of adverbs: French degree adverbs. In Stefan Müller (ed.), *Proceedings of the 10th International Conference on Head-Driven Phrase Structure Grammar, Michigan State University*, 26–46. Stanford, CA: CSLI Publications. DOI: 10.21248/hpsg.2003.2.



Abstract

While French degree words have been assigned several syntactic categories, we show that they are rather highly ‘polymorphic’ adverbs (they occur in all syntactic domains), which select the expression they modify on a purely semantic basis. Like French adverbs in general, they occur both to the left and to the right of the head they modify. Following previous work (a.o. van Noord and Bouma 1994, Abeillé and Godard 1997, Bouma et al. 2000), we assign them two different grammatical functions, adjuncts and complements. Semantically, they differ from quantifiers. We follow Kennedy (2000) who analyzes them as scalar predicate modifiers. Finally, the specific syntactic constraints that characterize a subset of them can be shown to follow from, or be related to, their weight properties (Abeillé and Godard 2000). We conclude that their apparently idiosyncratic properties fit into a more general theory of grammar.

Introduction

Degree words have been analyzed differently, depending on the syntactic domain where they occur. We show that they should simply be analyzed as adverbs. Like adverbs in general, they occur to the left or to the right of the head of the expression they modify; as with adverbs in general, we assign them two grammatical functions: adjuncts and complements. There is no need to make degree words special, either regarding their part of speech or their function.

It is a matter of some debate whether degree words are quantifiers, or predicate modifiers. We consider them to be predicate modifiers, selecting a scalar predicate. Their syntactic polymorphism follows from the fact that they select the expression they modify on a purely semantic basis, and that expressions of different syntactic categories can be scalar.

A subset of degree adverbs shows certain interesting distributional restrictions. These are related to the weight (lightness) properties of some degrees, which also characterize adverbs of other semantic classes. Our hierarchy of weight includes ‘weak’ forms among weight deficient forms, a move which helps explaining why a few adverbs appear to be less polymorphic, appealing to a ‘blocking effect’.

1 The main properties of French degree words

1.1 Degree words are adverbs

Degree words have not always been analyzed as adverbs. In particular, they have been classified as ‘degrees’, ‘Q(uant)’ or ‘determiners’ in the adjectival or nominal domains (e.g. Milner 1973, 1978, Gross 1977, for French; see also Jackendoff 1977, Corver 1997). They are best analyzed as adverbs in all of their occurrences.

- **Syntactic polymorphism**

A striking property of degree words is that they can modify expressions belonging to all syntactic categories as illustrated in (1). This follows if degree adverbs select the expression they modify essentially on a semantic (rather than syntactic) basis (see also Doetjes, 1997).

- (1)
- Paul a **exagérément** apprécié ce film.
Paul has excessively appreciated this film
 - Autant** femme que reine, Marie commettait des erreurs.
As-much queen as woman, Marie was making mistakes
 - Complètement** ivre, il renonça sagement à conduire.
Completely drunk, he wisely gave up driving
 - Très** au courant des dernières découvertes, il gardait bon espoir.
Very up to date about recent scientific progress, he had good hopes
 - Il avait convaincu **beaucoup** de monde.
He had convinced much of people (= a lot of people)
 - Très** gentiment, il a proposé ses services.
Very kindly, he has offered his services

Although degree words are specially flexible, adverbs in a general way are not limited to the verbal domain; examples are given in (2):

- (2)
- evaluatives *bizarrement bleu , curieusement peu*
strangely blue, curiously little.
 - modals *probablement ivre, peut-être depuis Paris*
probably drunk, perhaps from Paris
 - agentives *intelligemment partisan des réformes*
intelligently adept of reforms
 - frequency adv *des collaborateurs souvent ivres, toujours à cheval*
associates often drunk, always on horses
 - negations *des enfants pas peureux, jamais en panne d'idées*
children not fearful, never without ideas
 - frames *globalement positif, légalement en charge de ce dossier*
globally positive, legally in charge of this problem
 - time adv *aussitôt ivre, aujourd'hui président*
immediately drunk, today president
 - manners *sincèrement amoureux/ partisan de*
sincerely in love / in favour of

- **Morphology**

Many degree words display the typical French adverb formation: they are derived from adjectives with the affix *-ment*, cf. (1a,c). Some of them are not so derived: *beaucoup, peu, trop, plus, autant, très*, etc., cf. (1b,d,e,f). However, the presence of the suffix *-ment* on an adjectival base is not necessary to define adverbs (see forms like *soudain* 'sudden(ly)', *souvent* ('often'), *jamais* ('never')).

Moreover, the phenomenon known as 'quantification at a distance' (3b) (Obenauer 1983, Doetjes 1997) indicates that the same adverb occurs in the nominal and verbal domains, since this adverb, which syntactically modifies a verb, must

semantically modify both the participle and the NP. Its occurrence is necessary for the object NP to be allowed, but it semantically selects the participle.

- (3) a. Paul a lu beaucoup de livres sur le sujet.
Paul has read a-lot of books on the topic
b. Paul a *(beaucoup) lu de livres sur le sujet.
P. has a-lot read of books on the topic
c. Paul a aimé beaucoup de films dernièrement.
Paul has loved a-lot of films lately
d. * Paul a (beaucoup) aimé de films dernièrement
Paul has a-lot loved of films lately

• **Degree words in the verbal domain**

In French, there is a clear criterion for defining adverbs: adverbs and only adverbs occur between the tense auxiliary and the past participle with an integrated prosody, as shown by the contrast between the adverb *souvent* and the NP *plusieurs fois*, in (4) (or the similar contrast between the adverb *gentiment* ‘kindly’ and the PP *d'une manière gentille* ‘in a kind way’, Sportiche 1994). See Abeillé et al. (2003), Abeillé and Godard (2003). Crucially, degree words (whatever their morphology) occur in this criterial position.

- (4) a. Paul a **souvent** conduit ses enfants à l'école.
Paul has often driven his children to school
b. *Paul a **plusieurs fois** conduit ses enfants à l'école.
Paul has several times driven his children to school
- (5) Paul a **trop / complètement** lu ce texte.
Paul has too(-much) / completely read this text)

A word of caution is in order here. The distributional contrast illustrated in (4) characterizes expressions with an ‘integrated’ prosody, that is, which are intonationally part of the sentence. Expressions with an ‘incidental’ prosody have different distributional properties (in particular, incidental NPs and PPs can occur between the auxiliary and the participle, Bonami et al. 2002).

Like French adverbs in general, degree words occur to the right of verbs, but not to the right of non-verbal categories (again, incidental adverbs may behave differently):¹

- (6) a. Jean téléphone beaucoup / excessivement / davantage à son frère.
Jean calls much / excessively / more to his brother
b. Excessivement inquiet, Paul se rongait les ongles.
Excessively worried, Paul was eating his nails
b'. ?? Inquiet excessivement, Paul se rongait les ongles.
c. Complètement femme, elle se réfugiait dans le sourire.
Completely woman, she took refuge in the smile
c'. * Femme complètement, elle se réfugiait dans le sourire.

¹ This is not true for (non-light) comparative adverbs, see examples (14c,d).

- (7) a. Toujours maire de son village, Jean était très occupé.
 Still mayor of his village, Jean was very busy
 a'. *Maire toujours de son village, Jean était très occupé.
 b. Evidemment/ Probablement séduisante, cette actrice ...
 Evidently / Probably attractive, this actress ...
 b'. ?? Séduisante évidemment/ probablement, cette actrice ...

While adverbs occur to the left of non-verbal and non-finite verbal categories, they do not occur to the left of finite ones in French (unless they are incidentals; we note incidentality by commas), see Bonami et al. (2002). Again, degree words (which cannot be incidentals) behave like adverbs in general.

- (8) a. Jean viendra probablement.
 Jean will-come probably
 b. Probablement *(,) Jean viendra.
 Probably, Jean will-come
 c. Jean *(,) probablement *(,) viendra.
 d. Jean aime beaucoup ce livre.
 Jean likes much this book
 e. * Beaucoup Jean aime ce livre.
 Much Jean likes this book
 f. * Jean beaucoup aime ce livre.

On the basis of this array of properties, we can safely conclude that degree words are adverbs.

1.2 The semantics of degree words

The semantics of degree words is a matter of debate. The question is whether they are *bona fide* quantifiers (with a domain of quantification, and a scope), or predicate modifiers. We follow Kennedy (2000), who argues that degree words should be treated differently from quantifiers.¹ In Kennedy's terms, degrees modify a predicate associated with a scale, with a contextually fixed value on the scale, and change this value.² Given that *beaucoup*, when it modifies a count event predicate, has an interpretation similar to that of the quantifier *souvent* (9), we follow Doetjes (1997) in comparing the two adverbs in their ad-verbial usage. The first set of arguments, which is line with Kennedy's approach, concerns scope properties. While *souvent* and a negation such as *aucun N* ('no N') exhibit scope ambiguities, this is not the case for *beaucoup*. In (9c), the interpretation where the adverb would have scope over the negation is absent.

¹ For a defense of the degree as quantifier approach, based on degrees of comparison, see Stateva (2002).

² Doetjes (1997)'s idea is similar (in her terms, degrees saturate an open quantity or grade position in another phrase). However, she assume that they are a special case of quantifiers ('degree quantifiers').

- (9) a. Elle va souvent / beaucoup au cinéma.
She goes often / a-lot to the movies
b. Elle ne voit souvent aucun étudiant.
She ne-sees often no student
'There is no student that she sees often'
'It is often that she does not see any student'
c. Elle ne voit beaucoup aucun étudiant.
She ne-sees no student
'There is no student that she sees a-lot'

Moreover, *beaucoup*, unlike *souvent*, always has lower scope than a scopal adverb. Given that a scopal adverb has scope over an adverb which follows it (see section 3.2), the impossibility of the order *beaucoup* + *longtemps* indicates that the degree adverb must be in the scope of the duration adverb.¹

- (10) a. Elle est souvent partie longtemps.
She is often gone long-time (she often went away for a long time)
b. Elle est longtemps partie souvent.
She is long-time gone often (for a long time she often went away)
c. * Elle est beaucoup partie longtemps.
d. Elle est longtemps beaucoup partie.

The fact that an expression exhibits scope ambiguities with scopal expressions may not be sufficient to indicate that it is a quantifier.² But the fact that it fails to exhibit ambiguities argues against its being a quantifier, specially in view of the contrast between *souvent* and *beaucoup*.

Doetjes (1997) gives a second set of arguments, showing that degrees cannot introduce their quantification domain, unlike a quantifier such as *souvent*. For instance, unlike *souvent*, *beaucoup* cannot impose iteration of the event. This is clear with a non-count predicate such as *pleuvoir*: while (11a) says that it rained lots of times, (10b) can only measure the amount of rain, without indicating whether it rained often, or once or twice but abundantly.

- (11) a. Il a souvent plu ce mois-ci.
It rained often this month
b. Il a beaucoup plu ce mois-ci.
It rained a-lot (= abundantly) this month

¹ *Beaucoup* can follow or precede a non scopal adverb such as a frame adverb (*professionnellement*):
(i) Ce livre me sert beaucoup professionnellement / professionnellement beaucoup. (this book helps me a lot job-wise)

² An NP including a degree word may exhibit scope ambiguities, as does the partitive construction in (i). However, a comparable ambiguity seems to exist with the definite NP, a fact which casts doubt on the explanation of the scope properties in terms of quantification in this case:

- (i) Paul a souvent lu beaucoup de ces livres. (P. has often read a-lot of these books)
'There are many of these books which P. has read often'
'There are many periods of time during which P. read a-lot of these books'
(ii) Paul a souvent lu ces livres. (P. has often read these books)
'These books, P. has often read'
'There are many periods during which P. has read these books'

Souvent, being a quantifier, introduces a domain of quantification, that is, a set of situations (which can be implicit, as in (11)), and quantifies by comparing this set with that associated with the rest of the sentence, see e.g. de Swart (1991). On the other hand, *beaucoup* does not do that: it must find a scale in the predicate which it modifies. Since the predicate ‘to rain’ is not countable, the scale cannot be defined in terms of number. We conclude that a degree adverb such as *beaucoup* does not behave like a quantifier.

Following Kennedy (2000), Kennedy and McNally (2000), we consider that degrees modify a value on a scale associated with a predicate. The scale is defined in terms of natural numbers as well as intensity, so that, as a class, they can modify count and mass predicates. The scale can be either closed (with a maximum value) or open (no maximum value). We distinguish three (main) subtypes of degree adverbs, depending on the scale type (Abeillé et al. 2003): (i) completion adverbs (they require a closed scale): *complètement, partiellement, etc.*; (ii) intensity adverbs (they require an open, intensity scale): *intensément, infiniment, etc.*; (iii) ‘pure’ degree adverbs (they underspecify the kind of scale they modify, intensity or quantity, Doetjes 1997): *trop, plus, beaucoup, énormément, etc.*

(12) scale types

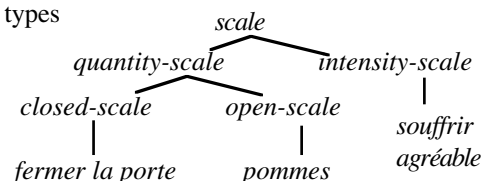

The compatibility between degree classes and the scale type is illustrated in (13):

- | | | | |
|------|-----|--------------------------------------|---|
| (13) | a. | Il a partiellement traduit le texte. | He has is partially translated the text |
| | a'. | ?? Il a souffert partiellement. | He has partially suffered |
| | b. | Il a souffert intensément. | He has suffered intensely |
| | b'. | * Il part intensément en voyage. | He goes away intensely |
| | c. | Il part beaucoup en voyage. | He goes away a-lot |
| | c'. | Il a souffert beaucoup. | He has suffered a-lot |

In (13b, c'), *intensément, beaucoup* modify a predicate with an open intensity scale. In (13a), *partiellement* modifies a predicate (*traduire le texte*) with a closed scale; this telic predicate denotes an event which can be divided into sub-events, which together form a scale of quantity. Since *partiellement* selects a predicate with a closed scale, it cannot modify a verb like *souffrir*. Since *intensément* selects a predicate with an intensity scale, it cannot modify a count predicate like *partir en voyage*. The only scale that can be associated with such a predicate is the number of occurrences of the event, that is a (open) quantity scale. Since *beaucoup* does not specify the scale type, it can modify *souffrir* as well as *partir en voyage*.

2 Degree adverbs as adjuncts

We propose that degree adverbs to the left of the expression they modify can be systematically analyzed as adjuncts. They have been considered as specifiers of A or N in e.g. Milner (1978), for French, Jackendoff (1977), Pollard and Sag (1994), Ginzburg and Sag (2000), for English; they have also been considered as heads of a functional projection, taking the AP as a complement (Corver 97); Doetjes (1997, 2001) divides them between functional heads and adjuncts; finally, they could be analyzed as specifiers of an abstract functional projection in the verbal domain, in the general approach to adverbs found specially in Cinque (1999). The functional projection approach to adverbs is criticized in Abeillé and Godard (2003) (see also Ernst 2002); we leave aside the question of such abstract projections, stressing some problems for the specifier analysis with the usual categories (N, A, V). After explaining our analysis, we turn to constraints on adjunction characterizing certain subsets of degree adverbs.

2.1 Degree adverbs are not specifiers

We note first that the specifier analysis of degree adverbs presents no advantage over our approach which attributes them two different grammatical functions, since it cannot cover all the cases. Specifiers occur to the left of the head in French. However, as illustrated above, degree adverbs can occur to the right of the infinitival V (14b'), and must occur to the right of the finite V (14a'). Accordingly, they cannot be considered specifiers of V. It would not be sufficient to say that, exceptionally, the verb can or must 'move' to the left of its specifier, since degree adverbs can scramble with complements (14b''): movement of complements must be added to V movement. Furthermore, degree adverbs can also occur to the right of N and A in some specific cases: comparative degree adverbs (if 'non-light', see section 2.3 on weight) can occur to the right of predicative N and A.

- (14) a. *Paul beaucoup téléphone à son frère.
Paul a-lot calls his brother
a'. Paul téléphone beaucoup à son frère
b. % Il craignait de complètement perdre la tête.
He was-afraid of completely los(ing) his mind
b'. Il craignait de perdre complètement la tête.
b''. craignait de perdre la tête complètement.
c. Présent davantage, il aurait été au courant.
Present more (often), he would have known better
d. Femme plus que reine, elle ne plaisait pas à la cour.
Woman more than queen, she did not like court life

The specifier analysis is problematic with verbs, even when they occur to the left. Specifiers are expected to occur at the highest structural level, and, hence, to have wide scope over a coordination of heads. This is not what we find with non-*-ment* derived ‘pure’ degree adverbs, which can only have wide scope over a coordination of lexical V_s, not over a coordination of VP_s:

- (15) a. * On lui reprochait de trop lire de BD et regarder de feuilletons.
 They faulted him of too(-much) read of comics and watch of soap operas
 ‘They criticized him for reading to many comic books and watching too many soap operas’
 b. On lui reprochait de trop lire et regarder de bandes dessinées.
 They faulted him of too-much read and watch of comics

The contrast in (15) shows that the degree adverb *trop* cannot have wide scope over the conjunction in (15a); if it did, it would allow the second object of the form ‘de N’. In order to account for these data, one would have to say that pure degree adverbs are specifiers of V, not of VP, a move which does not square well with usual X-bar theory. A simpler line of analysis is to follow that developed for some manner adverbs in French (cf. *bien, mal, mieux...*), namely to analyze pure degree adverbs as adjoined to V° (Abeillé and Godard 1997, 2001).

With non-predicative N_s, the degree adverb is followed by ‘de’ (*beaucoup *(de) chance / beaucoup *(de) problèmes*, a-lot of chance / a-lot of problems). This is unusual for specifiers which normally precede the N without ‘de’ (*trois / certains / les livres*, ‘three / some / the books’). The first possibility is that the two forms constitute a complex specifier. However, this option is not available, since the ‘de N_s’ can be conjoined:

- (16) a. beaucoup de pain et de vin
 a-lot of bread and of wine
 b. beaucoup de collaborateurs étrangers et de visiteurs
 a-lot of collaborators foreign and of visitors

Alternatively, the adverb could function as the specifier of the ‘de N’ constituent. The problem is that such a constituent can occur independently, without a specifier, as in negative contexts (17). Analyzing the adverb as a specifier in the nominal domain thus implies either that French N can occur without a specifier or that NPs can have several specifiers. The first option goes against the well-known fact that French lacks the ‘bare noun’ construction, the possibility for N to lack a determiner being extremely constrained and limited in a general way to predicative N (such as the adjunct N in (14e), or the object of a light verb in *rendre hommage* ‘pay tribute’, for instance). The second option goes against the usual assumptions of the X-bar theory, on which the specifier analysis is based.

- (17) a. Personne n'a pris de pommes / de pain.
 Nobody took of apples / of bread (nobody took any apples/ any bread)

- b. Je ne pense pas qu'on ait acheté de journal aujourd'hui.
I don't think that we bought of newspaper today

Since the analysis does not work for the verbal domain, and encounters problems even in the NP domain, where its justification would seem at first to be the least problematic, we conclude that degree adverbs should not be analyzed as specifiers.

2.2 Degree adverbs as adjuncts

The analysis of degree adverbs as adjuncts is straightforward. Polymorphism follows from the fact that degree adverbs do not specify the syntactic category of the head they adjoin to. We use the usual head-adjunct construction, which, enriched with (some) semantic features, is given in (19).¹ This construction allows the structures in (18) with degree adverbs, for instance, which illustrate some of the analyses discussed in the paper (for the adjunction of the adverb to a 'de NP', see Miller 1992, Doetjes 1997):

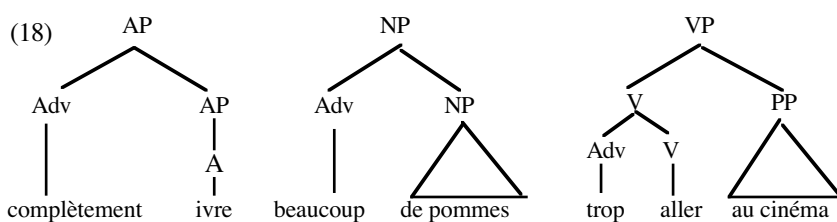

(19) *head-adjunct-construction* ⇒

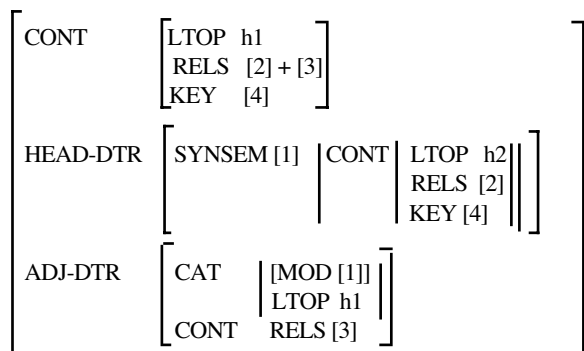

Adjunct degree adverbs obey two general constraints, which take the distinction between prosodically integrated and incidental expressions into account. The first (20a) says that only incidental expressions can adjoin to finite verbs. This accounts, in particular, for the data in (8), (14a).² The second (20b) orders non incidental

¹ We follow Sag et al. (2003) in distinguishing between constructions (or rules of grammar), which have daughters, and phrases (or words) which do not.

² As mentioned above, incidental ([INCID +]) adverbs have different distributional properties.

adverbs before the head they modify. It follows from (20b) that adverbs to the right of the head are not adjuncts.

(20) Two constraints on adjunction

- a. $\left[\begin{array}{l} \textit{head-adjunct-construction} \\ \text{HEAD-DTR} \text{IHEAD} [\textit{V finite}] \end{array} \right] \Rightarrow [\text{ADJ-DTR} \quad [\text{INCID +}]]$
- b. $\textit{head-adjunct-construction} \Rightarrow \text{ADJ-DTR} \left[\begin{array}{l} \textit{adverb} \\ \text{INCID -} \end{array} \right] \mathbf{precedes} \text{HEAD-DTR}$

A partial semantic description of the head-adjunction construction is given in (19), in a Minimal Recursion Semantics approach (Copestake et al. 2003). Relations from the daughters are added (they form a (multi-)set on the mother node); the KEY relation is that of the head daughter, but the semantic head of the construction is the adjunct daughter (Pollard and Sag 1994): the LTOP value of the construction is identified with that of the adjunct daughter. From this and the ordering constraint (20b), it follows that an adjunct adverb can only occur to the left of another adverb if it has scope over it.

Degree adverbs (partially) specify the semantics of the head they adjoin to. Although not all degree adverbs can modify ‘de NPs’, no syntactic constraint has to be added: completion adverbs cannot modify ‘de NPs’ because ‘de NPs’ are associated with an open scale (**complètement de pommes / d'argent*, completely of apples / money), and intensity adverbs cannot modify plural ‘de NPs’, because plural ‘de NPs’ are associated with a quantity scale (*infiniment de peine vs *infiniment de pommes*, infinitely of grief / apples).

We assume that the following are scalar predicates: plural and mass N, gradable adjectives and adverbs, psychological predicates and non count verbal predicates more generally, predicates denoting an event decomposable into parts, and iterated count event predicates, see Doetjes (1997), Kennedy (2000), Kennedy and McNally (1999). We represent scalar predicates as having a scale type with a SCALE VALUE attribute. We exemplify with a completion adverb. The entry for ‘pure’ degree adverb (e.g. *peu, trop*) is similar, except that it says nothing about the type of the scale (see (28)). We exemplify the composition of a pure degree adverb and a gradable adjective.

(21) *complètement* :

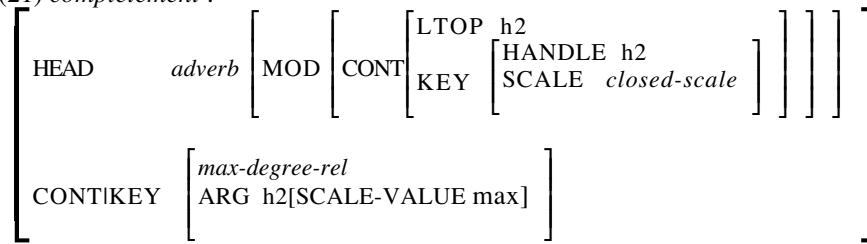

(22)

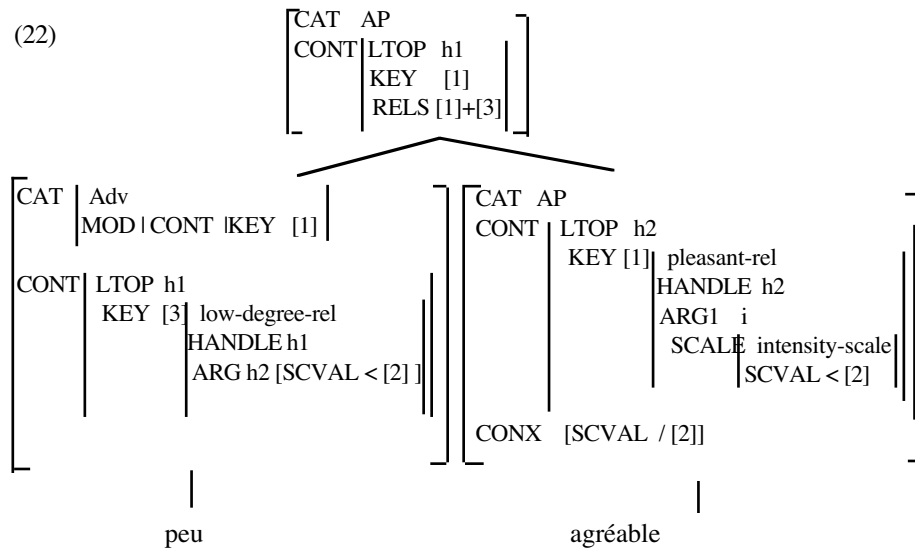

2.3 Light degree adverbs

We turn to constraints on adjunction which are related to weight, a syntactic feature appropriate for words and phrases, understood as in Abeillé and Godard (e.g. 2000). Here, we extend the hierarchy of weight types to include weak elements:¹

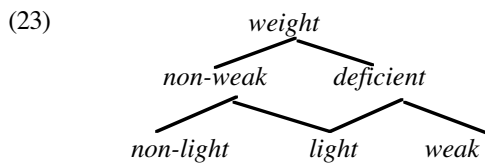

Weight deficient elements have the following characteristic properties: (a) they cannot be extracted; (b) they occur before non-light complements (except for adverbs) in the head-complements-phrase (see section 3.3). Contrary to light forms, weak forms cannot be modified or conjoined, nor occur in isolation (Cardinaletti and Starke 1994). They are necessarily words. Light forms can be conjoined or modified:

¹ We substitute the usual ‘light’ for ‘lite’ used in e.g. Abeillé and Godard (2000).

light constructions are coordinations or modifications, made of light elements. We have the following constraints:

(24) Weight and constructions

- a. *construction* => [WEIGHT *non-weak*]
- b. *construction* [MOTHER *light*] => [DTRS list ([WEIGHT *deficient*)]
- c. *head-complements-construction* =>
MOTHER [WEIGHT *non-light*], HEAD-DTR [WEIGHT *deficient*]
- d. *head-adjunct-construction* or *coord-construction* =>
HEAD-DTR [WEIGHT *non-weak*]

Some degree adverbs, the ‘beaucoup class’, adjoin to the lexical V, but not to the (non-light) VP (see (15), (18)). Actually, they adjoin to a light (rather than lexical) V, since they can adjoin to a conjunction of lexical Vs (see (15b)). They are pure degree adverbs and light (see section (41)). This constraint on adjunction is related to their weight, not to their semantic sub-class: a few manner adverbs (*bien, mal*) behave identically (Abeillé and Godard 2000, 2001), and a few pure degree *-ment* degree adverbs (*énormément, excessivement, suffisamment*), as well as completion (*complètement*) and intensity (*profondément*) adverbs behave differently. Derived *-ment* adverbs are non-light, can have wide scope over a conjunction of VPs (at least for some speakers, hence the ‘%’ notation), and adjoin to VPinf.

- (25) a. % Il craignait de ne pas suffisamment plaire à une compagne ni aimer les enfants pour se lancer dans le mariage.
He was afraid not to sufficiently please a companion nor love children to dare getting married
- b. % Il craignait de complètement perdre la tête et rater ses examens.
He was afraid of completely lose his mind and fail his exams
- c. % Il avait réussi à profondément choquer les spectateurs et impressionner ses collègues.
He had succeeded in profoundly shock(ing) the audience and impress(ing) his colleagues

However, even adverbs of the ‘beaucoup class’ adjoin to non-light non-verbal categories. Thus, they are adjoined to a non-light NP, Adv, and AP in (26,a,b,c):

- (26) a. trop [de pommes] / trop [en colère] (too of apples / too in rage)
- b. plus gentiment, plus probablement (more kindly, more probably)
- c. ? quelqu'un de plus intéressé par le job et capable de dévouement
somebody of more interested in the job and capable of devotion

Moreover, a non-light degree adverb can adjoin to a light head, as we can see with attributive adjectives. The relative order of adjectives and nouns in French depends on several factors; one of them is weight: adjectives to the left of the N are light, adjectives to the right of the N are non-light (Abeillé and Godard 2000). For

instance, no adjectives can precede the N if they have complements (27a, a'), or if they are modified by a *-ment* (non-light) adverb (27b, b'). On the other hand, an adjective modified by a light degree adverb can occur both prenominally and postnominally (27c).

- (27) a. une facile victoire / une victoire facile
 an easy victory / a victory easy
 a'. *une facile pour vous victoire / une victoire facile pour vous
 an easy for you victory / a victory easy for you
 b. ?? Une [suffisamment / excessivement grande]_{AP} difficulté
 a sufficiently / excessively big difficulty
 b'. Une difficulté [suffisamment / excessivement grande]_{AP}
 c. un [très bon]_{AP} résultat / un résultat [très bon]_{AP}
 a very good result

All these data follow from our hypotheses regarding weight: a head-complements-construction is non-light, a head-adjunct-construction with a non-light daughter is non-light, and a head-adjunct-construction with two light daughters can function either as a light or non-light phrase. Accordingly, French does not support a general weight constraint such that adjuncts and heads should have the same weight (contrary to the constraint proposed for English in Sadler and Arnold 1994). The constraint illustrated in (15) is lexically specified, characterizing a class of light degree and manner adverbs, which adjoin to light Vs, but do not specify the weight of the other categories. Thus, the weight specifications for *trop* are as in (28):

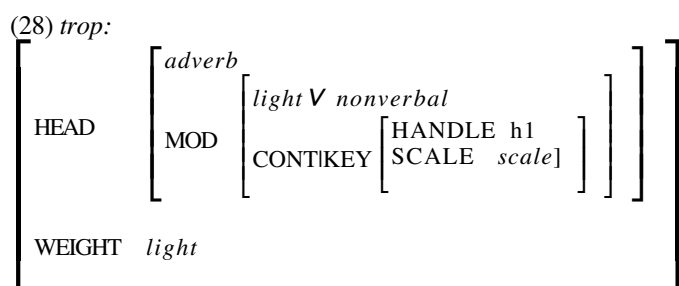

In addition to this lexical constraint, weight is also relevant for the ordering of the daughters of the head-adjunct construction. Adjoined degree adverbs follow more general constraints:

- (29) Ordering constraints on the head-adjunct-construction:
 a. HEAD-DTR [*noun*] **precedes** ADJ-DTR [*non-light*]
 b. ADJ-DTR [*light*] **precedes** HEAD-DTR
 c. ADJ-DTR [*adverb*] **precedes** HEAD-DTR

2.4 Weak degree adverbs: the *beaucoup/ très* alternation

A few pure degree adverbs (*beaucoup* ‘a-lot, much’, *tant* ‘so-much’, *autant* ‘as-much’) can only adjoin to verbs and ‘de NP’, which seems to threaten the generalization that degree adverbs do not syntactically specify the modified category. In fact, they are in complementary distribution with the corresponding adverbs *très*, *si*, *aussi*, which only adjoin to non-verbal predicative categories (Gatone 1981).

- (30) a. Paul a [très/ si peur]NP (has very / so fear)
 b. Paul est très gentil / en colère. (very kind / very-much in a rage)
 c. Paul est si gentil / en colère. (so kind/ so-much in a rage)
 d. * Il ne faut pas * très / si manger ! (one does not very/ so eat)
 e. * très de pommes / de chance (a-lot of apples / of chance)
- (31) a. * Paul est beaucoup gentil / en colère. (a-lot kind/ in a rage)
 b. * Paul est tant gentil/ en colère. (so kind/ so-much in a rage)
 c. Il ne faut pas beaucoup / tant manger. (one does not a-lot/ so-much eat)
 d. beaucoup de pommes / de chance (a-lot of apples / of chance)

We follow Doetjes (2001) in analyzing this distribution as a blocking effect: where the more constrained forms can occur, the less constrained forms are not available. Following Abeillé et al. (2003), we propose that *très /si /aussi* are weak forms: they cannot be modified, conjoined or occur in isolation (32); the others are light, not weak. As explained in section 2.3, we consider weak to be one possible value for the feature WEIGHT. Given (33), the lexical entry for *très* is as in (34).

- (32) a. Paul est-il fort ? – * Vraiment très. (Is Paul strong? – really much)
 b. ?? un homme très ou trop fort (a man very or too strong)

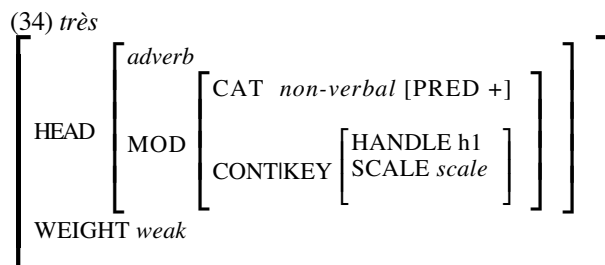
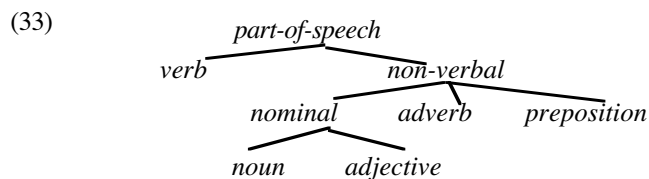

3 Degree adverbs as complements

3.1 The analysis

Following van Noord and Bouma (1994), Abeillé and Godard (1997), Bouma et al. (2000) a.o., we analyze degree adverbs as complements when they occur to the right of the modified category. This provides a straightforward account of the fact that adverbs (unless they take a propositional argument, e.g. Abeillé and Godard 2003) can scramble with non adverbial complements ((14b',b'') and (35a,a')), given that complements scramble in French (35b,b'). It also accounts for that fact that they can be clefted (35c):

- (35) a. Jean a complètement raté son examen.
a'. Jean a raté complètement son examen.
Jean failed his exam completely
b. Jean donnera une pomme à chacun.
b'. Jean donnera à chacun une pomme.
Jean will give an apple to each of them
c. C'est profondément qu'il a choqué les spectateurs.
It is deeply that he shocked the audience

Some degree adverbs are lexically subcategorized complements (36), while most are added to the dependent list of the verb following a lexical construction:¹

- (36) a. Paul mange sa soupe / mange beaucoup. (Paul eats his soup / a lot)
a'. * Paul mange beaucoup sa soupe (Paul eats a lot his soup)
b. Ça coûte plus / davantage (it costs / is worth more)
b'. * Ça coûte / vaut. (it costs / it is worth)

To get postverbal adverbs as complements of the V, we use a 'lexical construction', given in (37). A lexical construction has the advantage over a lexical rule not to create a potentially infinite lexicon. The lexical construction implies checking 'on the fly' that the argument list of the V is extended to include adverbs, and does this each adverb at a time. An adverb can be taken as an argument if its MOD value concerning the HEAD and KEY features match those of the V. Accordingly, selectional restrictions are taken into account; for degree adverbs, this takes care of the requirement that the key relation be scalar. Each adverb takes the verb (which may be already an extended verb, the semantic argument of the adverb being the verb's LTOP value rather than its KEY's value) as its semantic argument,² and the new LTOP of the extended verb is that of the adverb. This ensures that the adverb has scope over the content of the verb and other complement

¹ The first element of the dependent list is the subject, the others are complements.

² With degree adverbs, the LTOP of the verb is identical to the KEY's handle, see (21).

(39) Ordering constraints on head-complements-construction

- a. *head-complements-construction* => HEAD-DTR **precedes** COMP-DTRS
- b. *head-complements-construction* => [*adverb*] **oblique-precedes** [*adverb*]

An example involving two adverbs in a VP (cf. (38a)) is given in (40):

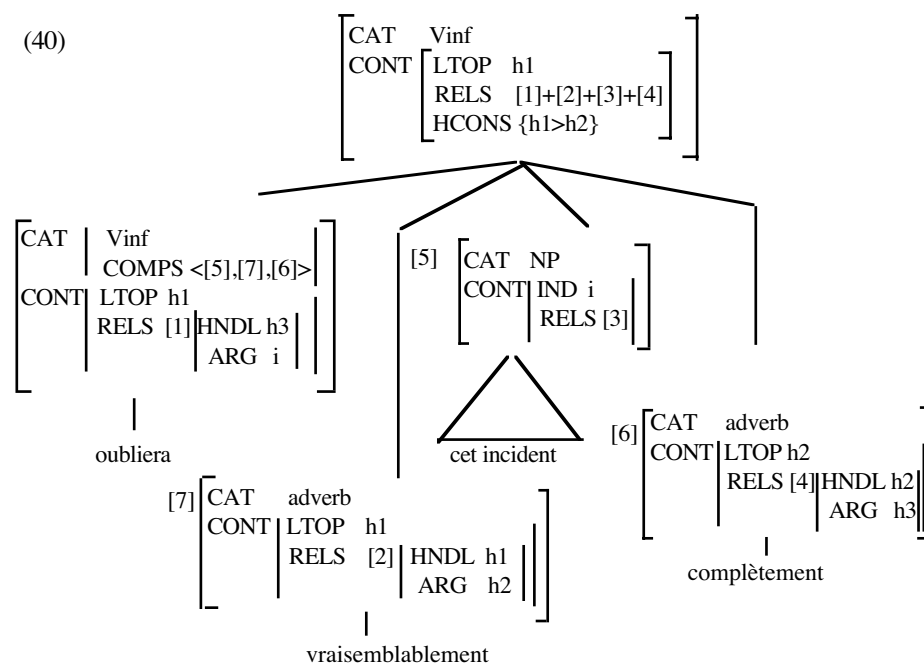

3.3 Light complement adverbs

The lightness constraint on ordering applies to complements in general. Adverbs such as *pas*, *plus*, *bien*, *mal*, *trop*, *beaucoup* are light, while adverbs such as *aucunement*, *correctement*, *abondamment* are non-light. Note that light adverbs belong to different semantic classes: negations, manner and degree adverbs. Light adverbs do not scramble with other complements (Blinkenberg, 1928), unless they are modified or stressed, and cannot be extracted (see section 2.3).

- (41) a. *Marie traite son frère bien.
Mary treats her brother well
- b. Marie traite son frère [vraiment très bien].
Marie treats her brother really very well
- c. *Marie voit son frère trop.
Marie sees her brother too much
- d. Marie voit son frère [trop ou trop peu], suivant les moments.
Marie sees her brother too much or too little, depending on circumstances

On the other hand, non-light adverbs can occur before light adverbs or nouns etc., as seen in (42), where the non-light *vraisemblablement* precedes the light Adv *bien* and the light N *raison*. This shows that light complements (adverbs or nouns) are not incorporated into the V.

- (42) a. Marie voit vraisemblablement trop son frère.
 Marie sees probably too(-much) her brother
 b. Marie a vraisemblablement raison.
 Marie has probably reason (= is probably right)

Constraint (43) covers the different effects of the weight distinction among complements. It allows non-light adverbs (which are [ADV+]) to precede light advs or Ns, while forcing the latter to precede non-light, non adverbial ones (NP or PP).

- (43) *head-complements-phrase* => [light] precedes [non-light [ADV -]]

Constraint (43) is illustrated in (44) (*voit beaucoup son frère*, sees a-lot his brother, *mange bien sa soupe*, eats well his soup). On the other hand, since no constraints are specified for non-light complements and adverbs, they are free to scramble among themselves, as illustrated in (45) (*ferme la porte complètement*, closes the door completely, *mange sa soupe correctement*, eats his soup correctly).

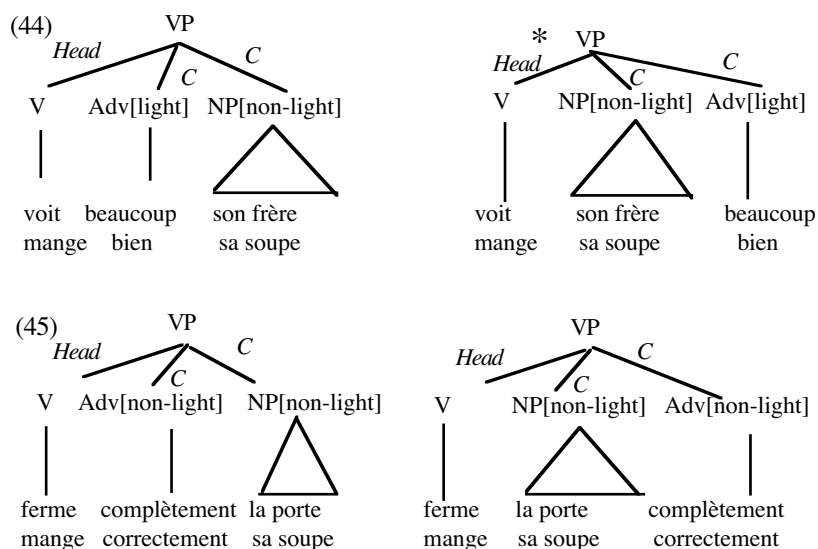

Conclusion

French degree words are interesting syntactically because of their extreme polymorphism (they modify any category) and certain distributional constraints on a

sub-set of them. We show that their syntactic properties follow if they are analyzed as adverbs, which, like French adverbs in general, have two possible functions: adjuncts or complements. Like other adjuncts and complements, they can be further constrained depending on their syntactic weight. In order to account for their polymorphism, we propose that they select the element they modify on a purely semantic basis: they modify scalar predicates and change the standard value associated with that scale. Most of their idiosyncratic properties are thus reconciled with a general theory of grammar.

References

- Abeillé, A., and D. Godard. 1997. The Syntax of French Negative Adverbs, in D. Forget et al. (eds) *Negation and Polarity, syntax and semantics*, 1-27. Amsterdam: John Benjamins.
- Abeillé, A. and D. Godard. 2000. French word order and lexical weight, in R. Borsley (ed) *The Nature and Function of syntactic categories, Syntax and semantics*, 325-360. New York: Academic Press.
- Abeillé, A. and D. Godard, 2001. A class of lite adverbs in French, in J. Camps, C. Wiltshire (eds) *Romance syntax, semantics and their L2 acquisition*, 9-25. Amsterdam: J. Benjamins.
- Abeillé, A. and D. Godard, 2003. French adverbs without functional projections, in M. Coene and A. d'Hulst (eds) *Comparative Romance Linguistics*, Amsterdam: J. Benjamins. (to appear)
- Abeillé, A., J. Doetjes, A. Molendijk, and H. de Swart. 2003. Adverbs and Quantification, in F. Corblin and H. de Swart (eds) *Handbook of French semantics*, Stanford: CSLI (to appear).
- Blinkenberg, A. 1928. *L'ordre des mots en français moderne*, Copenhagen: Bianco Lunos Bogtrykkeri, *Historik-filologiske Meddelelser XVII:1 et XX:1*.
- Bonami, O., D. Godard and B. Kampers-Manhe. 2002. Adverb Classification, in F. Corblin and H. de Swart (eds) *Handbook of French semantics*, Stanford: CSLI (to appear).
- Bouma, G., R. Malouf, and I. A. Sag. 2000. Satisfying constraints on extraction and adjunction, *Natural Language and Linguistic Theory* 19: 1-65.
- Cardinaletti, A. and M. Starke. 1999. "The Typology of Structural Deficiency: on the three grammatical classes", in H. Riemsdijk (ed) *Clitics in the Languages of Europe*, Berlin: Mouton de Gruyter.
- Cinque, G. 1999. *Adverbs and Functional Heads, a cross-linguistic perspective*, Oxford: Oxford UP.
- Copestake A., D. Flickinger, I. A. Sag, and C. Pollard. 2003. *Minimal recursion semantics: an introduction*, MS, Stanford University.
- Corver, N. 1997. The Internal syntax of the Dutch extended adjectival projection, *Natural Language and Linguistic theory*, 15, 289-368.

- Doetjes, J. 1997. Quantifiers and selection. On the distribution of quantifying expressions in French, Dutch and English, The Hague: Holland Academic Graphics (HIL dissertation series).
- Doetjes, J. 2001. *Beaucoup* est Ailleurs. Expressions de degré et sous-spécification catégorielle, in R. Bok-Bennema, B. de Jonge, B. Kampers-Manhe & A. Molendijk (eds.) *Adverbial Modification*, Amsterdam: Rodopi.
- Ernst, T. 2002. *The Syntax of adjuncts*. Cambridge: Cambridge University Press.
- Gaetone, D. 1981. Observations sur l'opposition *très-beaucoup*, *Revue de Linguistique Romane* 45. 74-95.
- Ginzburg, J. and I.A. Sag. 2000. *Interrogative Investigations; the form, meaning and use of English interrogatives*, Stanford: CSLI.
- Gross, M. 1977. *Grammaire transformationnelle du français : syntaxe du nom*, Paris: Larousse.
- Jackendoff, R. 1977. *X-bar Syntax: a study of phrase structure*, Cambridge, Mass: MIT Press.
- Kennedy, C. 2000. *Projecting the adjective: the syntax and semantics of gradability and comparison*, New York: Garland.
- Kennedy, C. and L. McNally. 1999. From event structure to scale structure: degree modification in deverbal adjectives. in T. Mathews and D. Strolovitsc (eds), *SALT 9*, 163-180. Ithaca: CLC Publications.
- Miller, P. 1992. *Clitics and Constituents in Phrase Structure Grammar*, New York: Garland.
- Milner, J-C. 1973. *Arguments linguistiques*, Paris-Tours: Mame.
- Milner, J-C. 1978. *De la Syntaxe à l'interprétation*, Paris: Le Seuil.
- Obenauer, H. 1983. Une quantification non canonique : la "quantification à distance", *Langue française* 48, 66-88.
- Pollard, C., I.A. Sag, 1994. *Head Driven phrase Structure Grammar*, Stanford: CSLI and Chicago: The University of Chicago Press.
- Sadler, L. and D. Arnold. 1994. Prenominal Adjectives and the phrasal/lexical Distinction, *Journal of Linguistics* 30,187-226.
- Sag, I.A., T. Wasow and E. Bender. 2003. *Syntactic Theory, a Formal Introduction*, Stanford: CSLI.
- Sportiche, D. 1994. *Adjuncts and adjunction*, *GLOW Newsletter* 32, 54-55.
- Stateva, P. 2002. *How different are degree constructions?* PhD dissertation, U. of Connecticut.
- de Swart, H. 1991. *Adverbs of quantification: A Generalized Quantifier approach*, PhD dissertation, University of Groningen.
- van Noord, G. and G. Bouma. 1994. *Adjuncts and the processing of lexical rules*, *Proceedings of COLING 15*, 250-256, Tokyo.

More heads and less categories: A new look at noun phrase structure

John Beavers 

Stanford University

Proceedings of the 10th International Conference on
Head-Driven Phrase Structure Grammar

Michigan State University

Stefan Müller (Editor)

2003

Stanford, CA: CSLI Publications

pages 47–67

Beavers, John. 2003. More heads and less categories: A new look at noun phrase structure. In Stefan Müller (ed.), *Proceedings of the 10th International Conference on Head-Driven Phrase Structure Grammar*, Michigan State University, 47–67. Stanford, CA: CSLI Publications. DOI: 10.21248/hpsg.2003.3. 

Abstract

Much literature in syntax has assumed that all noun phrases are categorically headed by the determiner or the noun, with well-formedness categorial in nature. In this paper I develop a theory of noun phrase structure in which both categories project noun phrases, arguing that this better fits the indeterminacy of the criteria often cited for determining headedness (Zwicky, 1985, *inter alia*). The only categorial differences between determiners and nouns are their semantics and selectional restrictions, and the conditions that determine well-formedness are semantic in nature. Specifically, a well-formed noun phrase must have some restrictive semantics associated with nouns coupled with some operational semantics associated with determiners (e.g. as a generalized quantifier), and from this I show how we can derive structural well-formedness. Thus the need for categorial well-formedness is nullified, providing an analysis with greater cross-linguistic import, being compatible with languages without determiners.

1 Introduction

Most theories of noun phrase structure (Harris, 1946, Jackendoff, 1977, Abney, 1987, Nerbonne et al., 1989, Payne, 1993, Pollard and Sag, 1994) have assumed that either the determiner (D) or the noun (N) is universally the syntactic head of the noun phrase (i.e. the element that categorially characterizes the phrase and determines its internal structure), and that a syntactically well-formed noun phrase is a fully saturated DP or NP, depending on the theory.¹ I will refer to such theories as theories of strict headedness. Much of the debate on noun phrase structure has been centered around whether it's the D or the N that is the head.

However, in this paper I argue that a careful examination of the data concerning headedness (cf. Zwicky (1985), Hudson (1987), Croft (1993), Zwicky (1993)) and noun phrase semantics does not support a strict headedness view. By examining a variety of old and new data, I will propose a semantically grounded alternative to strict headedness in noun phrases, characterized in (1):

- (1) (i) D and N are both *nominal* categories projecting nominal phrases (NomPs) and differ only in terms of semantics and selectional restrictions.
- (ii) A well-formed noun phrase is one that has both D and N-Semantics.

In other words, I propose that both Ds and Ns project noun phrases, with well-formedness dependent only on whether or not they are semantically complete. For any given noun phrase I maintain that there is indeed a unique head, and in particular for canonical noun phrases with both a D and an N I argue that the D selects for the N and heads the phrase, but in general it is possible for DPs or NPs to be well-formed noun phrases, conditioned only on semantic factors.

¹A note on terminology: I will use XP to stand for a phrase headed by category X, so a DP is a phrase headed by a D, and NP a phrase headed by an N. I will use "noun phrase" spelled out to refer to the pretheoretical notion of a noun phrase.

I discuss the data pertaining to headedness in section §2, concluding that no evidence isolates D or N as the head of the noun phrase. I turn to semantics in §3, arguing that there are semantic well-formedness constraints on noun phrase structure, and I look at the subcategorization properties of Ds and Ns in §4. In §5 I sketch a semantically driven analysis of bare plurals and noun phrase ellipsis, two instances of noun phrases that appear to be lacking either a D or an N. In §6 I sketch a way of removing any vestiges of syntactic well-formedness in noun phrase structure by moving to an underspecified semantic representation, with desirable cross-linguistic results. I'll compare this approach to alternative approaches in §7 and conclude in §8.²

2 Headedness

Turning first to the linguistic criteria that have been used to motivate headedness arguments, one of the first comprehensive surveys of what the valid criteria are is Zwicky (1985), although there has been much debate since on which of Zwicky's criteria are valid (see Hudson (1987), Croft (1993), Zwicky (1993)). Much of the debate, however, has been centered around the apparent indeterminacy of Zwicky's criteria, since they rarely isolate unequivocal heads for any construction, including noun phrases. However, I argue that the indeterminacy should instead lead us to a different conclusion, namely that there is no universal, single head for all noun phrases. I'll first go over the most common headedness criteria as applied to noun phrases and show that no conclusions can indeed be drawn.

The first criterion I'll examine is really a cluster of properties, usually characterized in terms of **obligatoriness**, wherein the head is the only obligatory element in a phrase. Variations of this criterion include **distributional equivalence**, wherein the head by itself has the same distribution as the full XP, and **category determination**, where the head is the thing that determines the category of the phrase. For example in the VP *eat (a sandwich)*, *a sandwich* is not obligatory and not distributionally equivalent to the full VP, but *eat* is obligatory, thus *eat* is likely the head. If we examine the data on noun phrases, however, neither D nor N appears to be obligatory or solely distributionally equivalent to the noun phrase:

- (2) (a) English: *Some dogs/dogs/some*
- (b) German: (*die*) (*alten*) (*Männer*) 'the old men'
- (c) Spanish: (*los*) (*gatos*) (*viejos*) 'the old cats'
- (d) Quechua:
 alkalde-kuna-ta mayor-PL-ACC 'the mayor [object]'
 hatun-kuna-ta big-PL-ACC 'the big ones [object]' (Croft, 1993)

In the English data in (2a) the full noun phrase *some dogs*, the N *dogs*, and the D *some* are all well-formed noun phrases, with roughly the same interpretation

²This sketch is based partly on a larger proposal in ? that also incorporates pronouns, proper names, possessors, possessive ellipsis, and *one*-anaphora. For purposes of this section I'll focus exclusively on D and N, ignoring most of these additional phenomena, although I'll make occasional reference to data beyond these two categories.

(taking into account of course ellipsis and generic/indefinite interpretation of bare plurals). Likewise for German and Spanish, any of D, N, and Adj can (by itself) constitute a valid noun phrase, and in Quechua N or Adj can. Therefore it doesn't appear obvious that any one element is, superficially, obligatory in the noun phrase.

The second criterion often cited for headedness is **subcategorization**, in the sense that the head is the item that subcategorizes for the non-head (where "subcategorize" means "requires the presence of" and not any particular theory of subcategorization). Here again we see the same indeterminacy:

- (3) (a) N subcategorizing for D:
**(The/this/that/a) picture of Mary is in black and white.*
 (b) D subcategorizing for N:
*A/the/every *(dog) slept soundly.*

In (3a), certain Ns (bare singular Ns) in some contexts require the presence of a D for well-formedness (barring potential "Universal Grinder" readings that occur in other contexts). Likewise, in (3b), some Ds (the articles *a/an* and *the* and the determiner *every*) categorically require the presence of an overt N. So it doesn't appear to universally be the case that D or N is necessarily subcategorizing for the other, thus furthering the indeterminacy of headedness. Turning next to morphology, it has been argued (in particular by Zwicky (1985), but see also Hudson (1987)) that the head is the element of the phrase that is the **locus of morphosyntactic marking**, e.g. inflection. Here again, however, we see that this criterion does not isolate a single head, since D and N share category features:

- (4) (a) D/N show person/number morphology:
John saw some dogs/a dog.
 (b) D/N show case:
 German:
den Mann the-ACC man "the man [object]"
der Mann the-NOM man "the man [subject]"
des Mannes the-GEN man-GEN "the man's"
 Russian:
temi poslednimi bol'šimi butylkami
 that.INST.PL last.INST.PL big.INST.PL bottle.INST.PL
 'with those last big bottles'
 (c) (Pronominal) Ds show case in English:
*We/*us linguists need more sleep.*

In (4a), we see that in English both D and N show person and number morphology (third person singular/plural in this example, see also the Quechua data in (2)). In (4b,c), we see that D and N (and Adj in Russian and in Quechua above) show case marking, even in English (on the assumption that pronouns in such uses

as (4c) are pronominal determiners). Thus it does not appear that of D, N, and even Adj any element is unequivocally the morphosyntactic locus of the phrase and thus its head. Finally, Croft (1993) in particular argues that the only true criteria for headedness is semantics, wherein the head is the element that is the most **semantically characteristic** of the whole phrase. For example, *eating a sandwich* is a kind of *eating* but not a kind of *sandwich*, so therefore *eating* is the head. This is a very difficult criterion to apply to noun phrases due to the semantic infelicity of such tests. For instance, it makes about as much sense to say that *every dog* is a kind of *dog* as it does to say that *every dog* is a kind of *every*, although this may be a purely trivial meta-linguistic fact. However, given that the interpretation of a noun phrase like *every dog* (as a set, a referential entity, a generalized quantifier, etc.) is not necessarily a cut and dry issue it's not clear that this test would be fruitful however formulated. Therefore on semantic grounds it's not entirely clear that either the D or the N is the head of the noun phrase.

Despite the indeterminacy, most people have concluded that the D or the N is the head anyway. Zwicky (1985) for instance concludes that the head most closely corresponds to the morphosyntactic locus, which he regards as the N, claiming the rest of the criteria are independent. Hudson (1987), on the contrary, argues that the D is the head by reevaluating most of Zwicky's criteria in terms of semantic functorhood, wherein he regards the D as the semantic functor in a noun phrase and argues that the retooled criteria concur with this notion. Croft (1993) assumes third the possibility that none of the criteria are any good, although he ultimately takes a semantically based view of headedness related to semantic "aboutness". I instead assume the fourth possibility, which, with no additional assumptions, is the most parsimonious: since D and N project phrases that are interchangeable (cf. (2)), place constraints on each other's distributions (cf. (3)), and have the same morphosyntactic category features (cf. (4)), then they are the same category and thus *both D and N project noun phrases*.³

This generalization can be encoded quite straightforwardly into the part-of-speech type hierarchy of an HPSG grammar (based on Ginzburg and Sag (2000)):

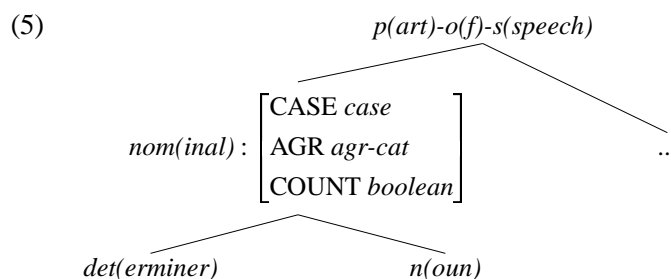

The type *nominal* I will assume has the relevant category features of both D

³See Postal (1966) for a similar argument about D and Pro; Hudson (2000) assumes that Ds are just transitive Pros, which means that if Pro and N are related categories then so are D and N.

and N, and that D and N are its subtypes (represented by *det* and *n*).⁴ I will furthermore assume that what verbs are selecting for are not NPs or DPs but simply NomPs, something headed by either element. Before encoding this formally, I will discuss what differences do exist between D and N, namely semantics and subcategorization, in the following sections.

3 Semantics

Despite the categorial relatedness of Ds and Ns, there are of course clear semantic differences between them, namely that Ns are associated with thematic information and Ds with some sort of operative semantics, informally outlined in (6):

- (6) (a) D-Semantics: quantification, definiteness, genericity, etc.
 (b) N-Semantics: attributive/restrictive semantics, the restriction set (*dog'*, *cat'*, *fish'*, etc.) of some kind of quasi-quantificational operator.

This is a largely uncontroversial observation (basically it's just saying that Ns are kind denoting and Ds contribute quantificational/referential properties (Szabolcsi, 1987, Longobardi, 1994, Chierchia, 1998), or that Ns denote restrictions and Ds denote set relations in a generalized quantifier (GQ), e.g. see Montague (1974), Barwise and Cooper (1981)).⁵ I encode this distinction into a semantic type hierarchy based on Ginzburg and Sag (2000) (with new types in boldface):

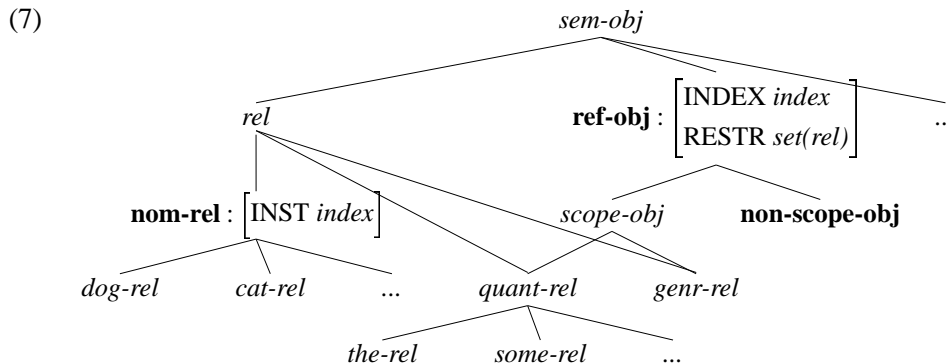

To Ginzburg and Sag's hierarchy I add a supertype *ref-obj* for all nominal semantics, a type *non-scope-obj* for nominal items (like nouns) that do not inherently contribute scopal semantics, and a type *nom-rel*, corresponding to N-semantics. Subtypes of this type include nominal predicates such as *dog-rel*. The type *scope-obj* corresponds to D-semantics. I propose the following lexical constraints linking these semantic types to the categories outlined above:

⁴Potentially, though I will not explore this option, separate categories for D and N may even be unnecessary once semantic and valence information is examined.

⁵Not all languages encode D-semantics via determiners, of course, using instead context, pragmatics, other morphosyntactic markers (like verbal prefixes in Mayan languages, aspectual markers in Russian, etc.). My claim is simply that when languages do have determiners they represent D-semantics. I'll return to cross-linguistic semantics in §6.

$$(8) \quad (a) \quad n\text{-}lxm : \left[\text{CONT} \left[\begin{array}{l} \text{non-scope-obj} \\ \text{INDEX } i \\ \text{RESTR} \left\{ \left[\begin{array}{l} \text{nom-rel} \\ \text{INST } i \end{array} \right] \right\} \end{array} \right] \right] \quad (b) \quad \text{det-}lxm : [\text{CONT } \text{scope-obj}]$$

Determiner lexemes have scopal semantics, whereas noun lexemes have non-scopal semantics but necessarily contain some *nom-rel* on their RESTR list predicating over their referential indices.⁶ With this hierarchy in place I now turn back to the linguistic data and note the following observation: all noun phrases have both D and N-semantics, as evidenced by (9).

- (9) (a) Noun phrase with both D and N:
- i. Every fish likes the movies.
- (b) Noun phrases with no N still have N-Semantics:
- i. Although most dogs eat dog food, many *e* prefer cat for dinner. (Ellipsis)
 - ii. (These (books)/)they record who won the 1967 World Series. (Pronominal))
- (c) Noun phrases with no D still have D-Semantics:
- i. (Some) people know who won the 1967 World Series. (Generic)
 - ii. I saw (some) dogs in the lawn. (Indefinite)
 - iii. (Kim knows the answer. (Definite))

In (9a) it's clear that full noun phrases, with both D and N, have the semantic components contributed by both elements (e.g. *every fish* has the D-semantics contributed by *every* and the N-semantics contributed by *fish*). Likewise, noun phrases such as those in (9b) which do not have overt Ns still have interpretations involving N-semantics, either due to pronominal co-reference or through some process of ellipsis (e.g. *many* in (9b.i) has the same interpretation as *many books*, receiving N-semantics anaphorically through ellipsis). Finally, noun phrases lacking overt Ds as in (9c) still have D-semantic interpretations, either as generics, indefinites, or definites. Therefore, regardless of the presence or absence of either the D or the N, all noun phrases have semantic components of both types of elements. This is by no means a new insight, but it allows us to state the following well-formedness condition:

- (10) Nominal Phrase Semantic Well-formedness Condition (NPSWC): All well-formed noun phrases must have both D-semantics and N-semantics.

I'll encode this criterion (and the NomP criterion from the previous section) directly into the selectional restriction of elements taking nominal arguments:

⁶This is not necessarily the case for expletives, which I ignore here, although they could be straightforwardly modeled using default constraints (Lascarides and Copestake, 1999).

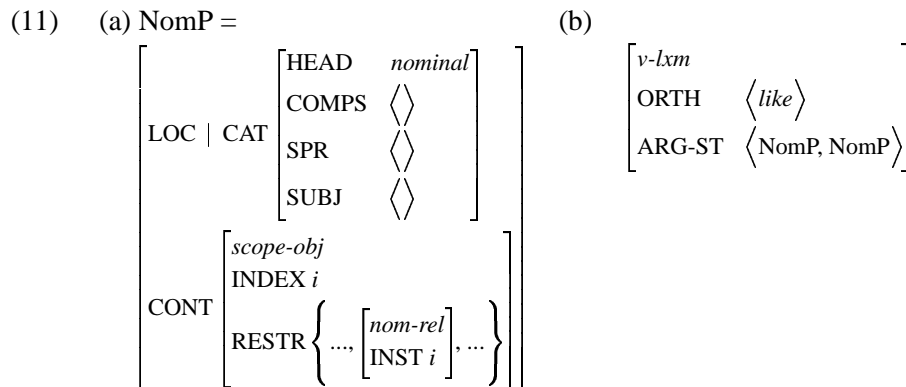

NomP is not a type; it is just an abbreviation for a feature structure representing a fully saturated noun phrase that has scopal (D-)semantics in which the referential index is predicated over by at least one nominal (N-)semantic element. Verbs like *like* take two NomP complements, rather than two NPs, thus encoding both the semantic and (lack of) categorial constraints motivated so far. In the next two sections, I'll examine the internal structure of various NomPs.

4 Subcategorization

Following Hudson (1984), Abney (1987), I'll assume that in general D subcategorizes for N (here meaning "selects for syntactically"), based not only on the type of evidence cited by much literature on DPs, but also additional, fresh data on Noun Phrase Ellipsis (NPE). I'll briefly recap the relevant data here. Abney assumes that D and INFL are parallel categories:

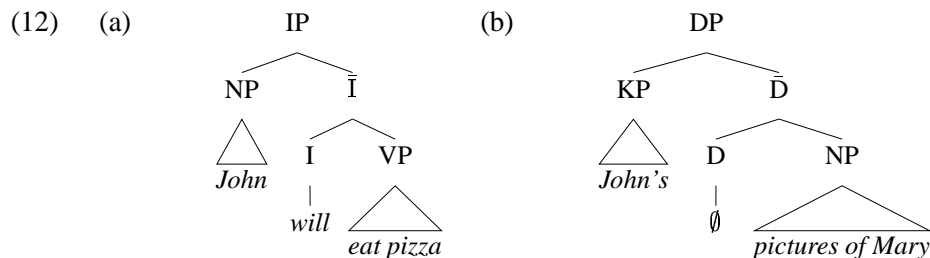

He supports this by showing that noun phrases and sentences are parallel projections, on the grounds that both have AGR (presumably a property of functional heads like INFL and, he argues, D) and related θ -grids. In terms of agreement and case features, there are striking cross-linguistic similarities between subjects of finite verbs and possessors. In many languages, such as Hungarian, Tzutujil, and Yup'ik, argument markings for subjects and possessors are identical:

- (13) (a) Hungarian:
- E'n nem akar-ok el-menni*
 I-NOM not want-1sg.indef away-go.inf
 "I don't want to go"

az en kalap-om
 the I-NOM hat-1sg
 “my hat”

(b) Yup’ik:

angute-m kiputa-a-∅
 man-ERG buy-OM-SM
 “the man bought it”

anguet-m kuiga-∅
 man-ERG river-SM
 “the man’s river”

(c) Tzutujil:

x-ix-qa-kunaaʃ
 aspect-2pOM-1pSM-cure
 “we cured you (pl.)”

qa-tzaʃn
 1pSM-nose
 “our nose”

(Abney, 1987)

In Hungarian possessors/subjects show nominative case, and in Yup’ik possessors and subjects of transitive verbs show ergative case. In Tzutujil there are no case markings, but the agreement morphology for verbs with their subjects and nouns for their possessors is identical, i.e. both are forms of subject agreement (separate morphology is used for agreement with objects). Looking more properly at agreement, many languages show the same morphology for subject/possessor agreement on both V and N, as in seen for Tzutujil in (13) and Yup’ik in (13) and also in (14):

- (14) (a) *kiputta-∅* “he bought it” *kuiga-∅* “his river”
 (b) *kiputaa-t* “they (dual) bought it” *kuiga-t* “their (dual) river”
 (c) *kiputaa-k* “they (plural) bought it” *kuiga-k* “their (plural) river”
 (Abney, 1987)

In (14) the inflectional paradigm for number agreement of Ns with possessors and Vs with subjects is the same, further strengthening the similarities between the noun phrase and sentential domains. Finally, the preservation of θ -role assignments in nominalization (e.g. *The Romans destroyed the city/the Roman’s destruction of the city*) indicates further structural and semantic similarities between noun phrases and sentences. Assuming an S/noun phrase parallel, D and INFL fall naturally into

same structural position, thus motivating Abney's structures in (12). Turning back to HPSG, there is of course no INFL category nor an AGR in the same sense as in Government and Binding, but the most natural analogy of the S/noun phrase parallel would be to assume (building on the category supertype of D and N) an analogy to the way auxiliaries interact with verbs (following Pollard and Sag (1994)):

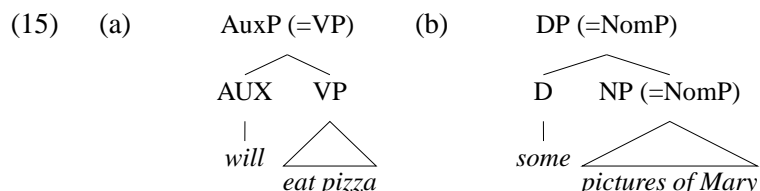

Just as Auxs are really Vs that take certain types of VP complements and project VPs, Ds are really Noms that take certain types of NomP complement (NPs) and project NomPs. In addition to Abney's data, there is also data on ellipsis that I think further supports the D/Aux parallel. Both D and Aux are capable of licensing ellipsis in highly parallel ways.⁷ Both Ds and Auxs license following NPs/VPs that may be overt, either non-anaphoric (regular NPs/VPs) or anaphoric (*one*-anaphora for Ds, *do so/it* anaphora for Aux), or else allow structures with covert NPs/VPs, either sense-anaphoric (ellipsis) or non-sense-anaphoric (for Ds, these are deictic or pronominal determiners that do not realize following NPs; for Auxs, these would be pragmatically controlled anaphora, which I'll turn to momentarily). This is summarized in (16).

(16)

		NPE		VPE	
		anaphor	non-anaphor	anaphor	non-anaphor
overt		<i>one</i>	NP	<i>so, it</i>	VP
covert		ellipsis	∅	ellipsis	∅

Examples of the four possibilities for both categories are outlined in (17).

(17)

		NP	VP
(a)	overt, anaphor (overt ellipsis):	<i>that one</i>	<i>did it/so</i>
(b)	covert, anaphor (ellipsis):	<i>some e</i>	<i>did e</i> (overt ant.)
(c)	overt, non-anaphor (full XP):	<i>some cat</i>	<i>did leave</i>
(d)	covert, non-anaphor (deixis):	<i>that e</i>	<i>did e</i> (pragmatic ant.)

Of the various kinds of ellipsis in English (gapping, sluicing, stripping, etc., cf. Ross (1967)), NPE/VPE are striking since they are the only two that allow overt elliptical elements. They also show striking distributional parallels. First, both allow pragmatic control, unlike gapping (Hankamer and Sag, 1976, Chao, 1988):

⁷I'll use NPE and VPE as cover terms for bare Auxs and Ds, although the interpretation is not always strictly speaking elliptical, as in the case of deixis.

- (18) (a) VPE: [In a context of two people eyeballing a freshly baked pie they know they're not supposed to taste yet] ?I will __ if you will __ .
 (b) NPE: [In the context of someone coming across a infestation of ants in her offi ce] ?Look, some__ got into my computer!
 (c) Gapping: [In a context of someone witnessing a dog chase a cat] *A cat __ a sparrow. (=A cat chases a sparrow)

In these examples both NPE and VPE at least marginally allow antecedents that are not linguistically overt in prior discourse, so in other words are “deep anaphora”, in terms of Hankamer and Sag (1976), unlike gapping.⁸ Second, neither NPE nor VPE need to be in a command/sisterhood relationship with their antecedents, unlike gapping (cf. Jackendoff (1971), Chao (1988)).

- (19) (a) VPE: John doesn't enjoy movies but Bill does __ .
 (b) NPE: Each mathematician left behind his glasses but most __ came back and got them.
 (c) Gapping: John loves chocolates and Bill __ Cheerios.
 (d) Gapping: *John persuaded Fred that Bill __ Sam.

VPE and NPE both allow unbounded antecedents (or antecedents in different sentences), unlike gapping and most other types of ellipsis, showing further similarities between them.⁹ In addition to the evidence of Abney that S and noun phrase are parallel projections, the ellipsis data shows very clearly the similarities between D and Aux. Based on this evidence, we can assume, just as Aux selects for V, that D select for N and that N does not take a specifier:¹⁰

⁸The picture is not quite as nice as this. Hankamer and Sag (1976) did not classify VPE as deep anaphors, claiming that evidence such as (18a,b) are ungrammatical. But since then a variety of further data have come to light suggesting that VPE does indeed behave like deep anaphora, including allowing pragmatic control in some contexts (Hankamer, 1978, Chao, 1988). Admittedly, the evidence on pragmatic antecedents is not entirely robust, certainly not as robust as similar evidence for, say, *do so* anaphora. Probably the best generalization that can be drawn is that VPE allows some pragmatic antecedents in some contexts. What is striking though is that NPE is perhaps equivalently as murky, suggestive still of their similarities.

⁹Note that Chao (1988) proposed a division of ellipsis types between VPE, sluicing, and Null Complement Anaphora (NCA) vs. gapping and stripping, where the former are H+ ellipsis, meaning the head of the phrase licensing the ellipsis is still present, and the latter are H- ellipsis, where the head has been elided. She shows a systematic set of distributional properties between the two. NPE patterns exactly like H+ ellipsis such as VPE on these grounds. If her typology is correct, then this is another argument that Ds head DPs since they are H+ ellipsis.

¹⁰This is a simplification of ?, where Ns do take possessor specifiers.

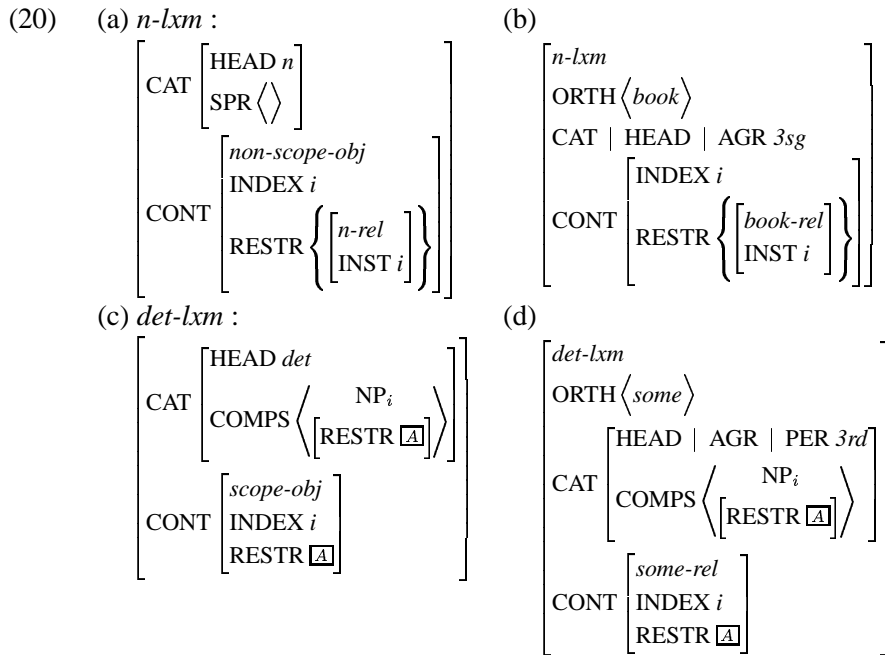

In (20a,c) we see the relevant selectional constraints, with examples given in (20b,d), incorporating also the semantic constraints outlined in the previous section, adding the constraint that Ds take their complements' INDEX and RESTR values. With these pieces in place, we can now see how NomPs with both a D and an N (i.e. a DP on this theory) are licensed both syntactically and semantically:

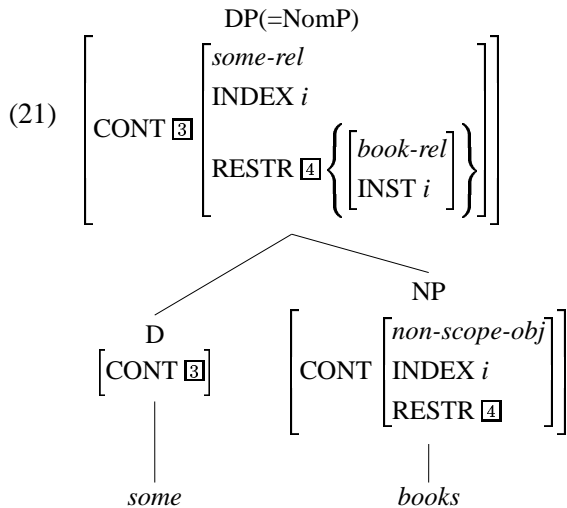

A NomP *some books* is licensed as a regular head complement construction, and the item on top is a fully saturated nominal projection whose semantics is a scopal object with an element on RESTR predicating of its index, thus satisfying the well-formedness criterion imposed by elements taking nominal arguments as in

(11). In the next section, I'll demonstrate how deviant noun phrases, those missing either an N or a D, can be licensed.

5 Missing Elements

So far, the theory outlined here currently has no account for data like (22) where there is no overt D or N.

- (22) (a) (Some) angry wolves steal (some) rice. (Bare plural/mass N, non-overt D)
 (b) There's squirrel all over the road. (Bare count N (Universal Grinder), non-overt D)
 (c) Although most sportscasters are still optimistic, some *e* wonder if the Cubs will ever win the series. (Ellipsis, non-overt N)

For English, the data appear to cluster into two distinct types:¹¹

- (23) • Bare N with indefinite/generic reading (bare plural/mass interpretation adds D-semantics).
 • Bare D with anaphoric semantics (N-semantics supplied by ellipsis).

So far, Ds and NPs like those found in (22) are not well-formed NomPs:

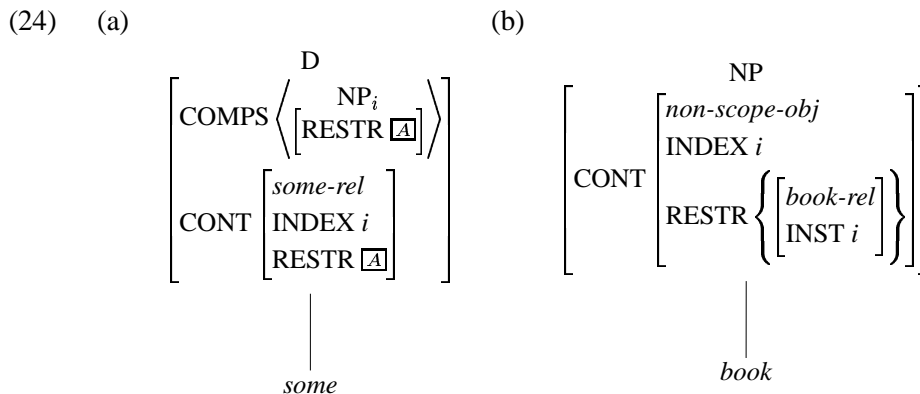

The problem isn't categorial since the common supertype of D and N allows either to head the NomP syntactically. However, there are semantic issues. The structure in (24a) is missing an N-semantic piece to satisfy the NPSWC in (11), as well as not being fully saturated. Likewise, the structure in (24b) is incomplete: although fully saturated it is lacking the D-semantics required of it to be a well-formed NomP. Following on this semantic anomaly, I'll propose the following informal analysis of bare nominals:

¹¹Although I'm not discussing proper names and pronouns it's worth pointing out that they satisfy a third part of this paradigm since they appear to come lexically packaged with D-semantics (definiteness) and only differ in whether they lexically have N-semantics (as in proper names) or acquire them through anaphoric reference (pronouns). Pronouns in particular optionally do show NP complements like determiners which may be unexpressed in ways other than ellipsis, something I'll return to in §6.

- (25) (i) The overt D or N is the syntactic head and supplies D or N-semantics respectively.
(ii) A specific interpretive processes (e.g. indefinite/generic pluralization or ellipsis) must supply the missing semantics to satisfy well-formedness.

The processes of bare nominalization and ellipsis needed in (22) can be encoded in a number of ways. For cases of bare NPs, we could simply modify the bare nominalization analysis of Ginzburg and Sag (2000) (ignoring AGR/COUNT features restricting the input to plurals/mass nouns):

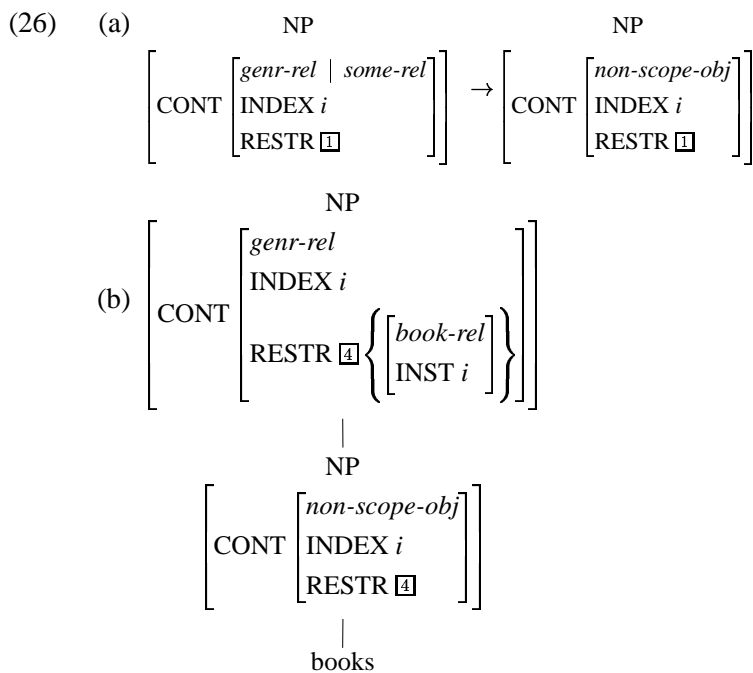

The rule in (26a) takes an NP without D-semantics as input and outputs a NomP with generic/indefinite D-semantics. An example application of this rule is given in (26b). The result of such a pumping rule is now a well-formed NomP: it is a fully saturated nominal category with D- and N-semantics. Note that this rule is largely semantic, operating purely on CONT values, something I'll return to momentarily. Turning to ellipsis, we can suppose because of the syntactic parallelism of D and Aux that NPE and VPE should be handled in parallel. Again, one simple account would be to adapt the VPE rule in Ginzburg and Sag (2000) as in (27a) to noun phrases (see also Hudson (1990)):

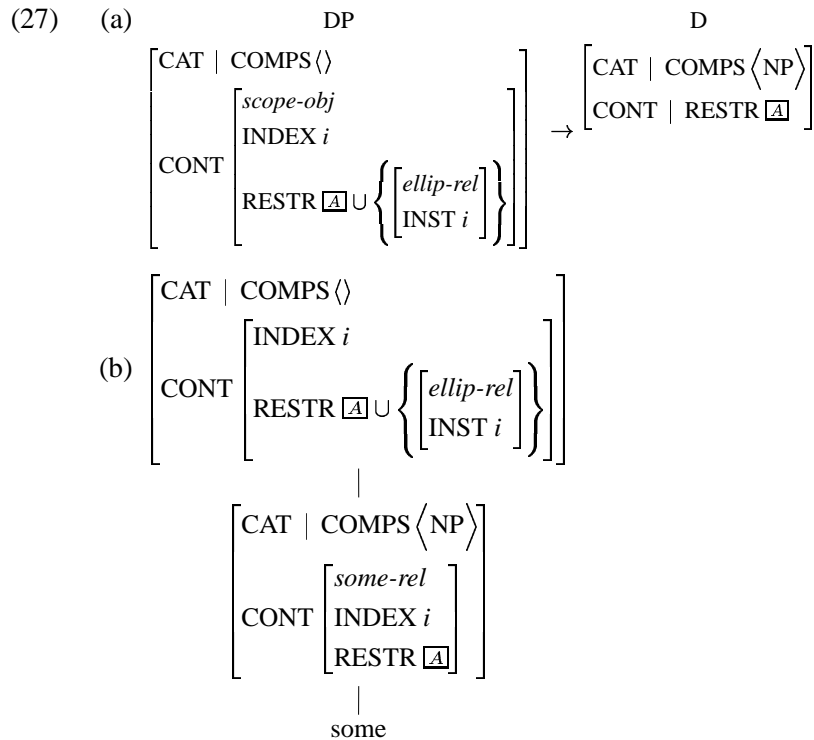

The NPE rule in (27a) takes a D without an NP complement, empties the COMPS list, and supplies a *nom-rel* in the RESTR of the output (the specific relation, *ellip-rel*, here just a place-holder for some elliptical semantics, the details of which are not relevant here). An example derivation is given in (27b). Again, the output of this rule is now a well-formed NomP, a fully saturated nominal phrase with D- and N-semantics. The close parallelism to the VPE rule in Ginzburg and Sag is telling; ideally, VPE and NPE could be done by one rule (as proposed in Jackendoff (1971)).¹² Via these two processes, we have an account of bare nominals and ellipsis that is at least no worse than, e.g., Ginzburg and Sag. Potentially, other missing D/N constructions cross-linguistically receive essentially equivalent treatments. Note that the rule in (27a), like (26a), is largely semantic, except for the syntactic component of emptying COMPS, and in the next section I will explore the possibilities of making both of these rules fully interpretive.

6 An All Semantic Approach

The analyses in the previous section are less than ideal since they involve non-branching pumping rules, i.e. syntactic machinery for which there is no overt syntactic evidence. Although frequently assumed in constructional approaches (see Ginzburg and Sag (2000)), they've also been argued against in terms of theoretical elegance (see e.g. Chomsky (1995)). In this section I'll argue that the two pumping rules can be eliminated by moving to an underspecified semantic representation.

¹²For instance by assuming an AUX-like feature for Ds/Auxs so that they form a natural class.

Note first that the rules in (26) and (27) operate almost exclusively on CONT values, save for the operation on CAT in the ellipsis rule. However, it's possible to eliminate the syntactic component of the ellipsis rule by assuming that Ds have optional complements, as in (28):

$$(28) \quad \det\text{-lxm} : \left[\begin{array}{l} \text{CAT} \left[\begin{array}{l} \text{HEAD } \textit{det} \\ \text{COMPS} \left\langle \left(\text{NP}_i [\text{RESTR } \underline{A}] \right) \right\rangle \right. \end{array} \right] \\ \text{CONT} \left[\begin{array}{l} \textit{scope-obj} \\ \text{INDEX } i \\ \text{RESTR } \underline{A} \end{array} \right] \end{array} \right]$$

This is not unmotivated: pronominal determiners *you/we* and deictic determiners *this/that/these/those* show optionality in complement selection (*we dogs/this (t-shirt)*). This is clearly not a process of ellipsis (i.e. it involves no “sense”-anaphoric reference) but instead resembles optional verb complements like *eat (a sandwich)* where the complement information is pragmatically inferred through some other means (as generic, definite, indefinite, etc.). Assuming optional complements for Ds means there's no need to change the CAT value in the ellipsis rule at all and then both rules in (26) and (27) would operate only on CONT values, thus being about as semantic as pumping rules can be given their inherently syntactic nature.

The advantage to this reconstrual is that it is also possible to eliminate the operations on CONT, and thus the pumping rules, by assuming an underspecified semantic representation, such as Minimal Recursion Semantics (see Copestake et al. (1999)). Among the many features of MRS is that it handles quantifier scope ambiguities by building representations that are underspecified for scopal relations between quantifiers, which can't be deduced from the syntax. Instead, some (potentially extra-grammatical) interpretive process incorporates a variety of grammatical, contextual, and pragmatic information to fully specify the scope relations. In a sense missing D- and N-semantics form a natural class with quantifier-scoping: they're semantic information which cannot be determined from the surface string. Following this parallelism, bare nominals/ellipsis can be treated just like quantifier scoping. On this approach, the grammar builds MRS structures that are simply underspecified for the missing D- or N-semantics. Rather than imposing the NPSWC syntactically as in (11), semantic well-formedness is a constraint on the processes that fully specify MRS structures: just as all fully specified MRS structures must be scope resolved, they must likewise have both D- and N-semantics for referential indices, as outlined in (29).

(29)	Process	Underspecified MRS	Fully Specified MRS
	Q-Scope	Underspecified scope	Must be scope resolved
	Ellipsis	Underspecified N-semantics	No vacuous quantification
	Bare NPs	Underspecified D-semantics	No free indices

Here the resolution of D- and N-semantics is localized to the mapping from underspecified MRS structures to fully specified ones, just as is done for quantifier scope resolution.¹³ (The processes that do the specification are presumably language specific, e.g. specifying D-semantics for English involves generic/indefinite interpretations, etc.) Thus the rules in (26) and (27) can be eliminated entirely. This is a theoretically desirable move: these pumping rules are essentially doing what specifying quantifier scope is doing in MRS, namely adding semantic information that can't be inferred from the syntax. Doing without the pumping rules puts the locus for specifying all underspecified semantics in one place instead of two.

This move also further supports the semantic well-formedness condition in (10) as the *only* condition necessary for noun phrase well-formedness. Pinning all of noun phrase well-formedness on semantics does beg some motivation, namely in answering the question: “why would we want an entirely semantic basis for noun phrase structure?” Here I think the answer comes from cross-linguistic syntax: not all languages have determiners, e.g. Estonian, Finnish, Japanese, Russian, etc., or else do not have the same class of determiners (compare English to Hungarian). Interpretation of D-semantics for these languages is based on other morphosyntactic or grammatical encodings as well as contextual, pragmatic, and distributional information. Any syntactic approach to noun phrase well-formedness (such as most strict headedness theories) inherently restricts the syntax to something less than universal since noun phrase structures vary so drastically cross-linguistically. The semantic approach sketched here does not fall prey to that. Assuming a cross-linguistic, universal semantic well-formedness condition for noun phrases with a single interpretive locus for specifying underspecified semantics (although with language specific processes) eliminates the need to posit any additional structure for languages for which it isn't attested.

7 Alternative Proposals with Multiple Heads

Before concluding it's worth comparing this approach to other approaches that have supposed that both D and N can head noun phrases in different contexts, e.g. Radford (1993), Netter (1994). Radford in particular proposes that D, N, Q(quantifier), and Adj are all “nominal” categories that embed one another recursively:

$$(30) \quad [_{DP} D [_{QP} Q [_{AdjP} Adj [_{NP} N XP]]]]]$$

Any substructure is a valid nominal phrase and heads share features (such as category features) via some form of feature passing. However, the process of feature passing and the notion of “nominal” categories receives no precise formulation in the Principles and Parameters framework Radford assumes; in a sense the HPSG analysis outlined here provides a precise way to encode these notions.

¹³The specific constraints imposed in (29) are familiar in more traditional representations like First-Order Logic (FOL) with GQs. The scoping constraints fall out of the recursive syntax for building FOL formulae, and the constraints against vacuous quantification and free variables are not unmotivated for some variants of FOL (see Dowty et al. (1981), Partee et al. (1990)).

Perhaps the most similar approach to the one outlined here is the HPSG account of Netter (1994), who proposes that D and N are functional and non-functional versions of the same category (see also Chomsky (1986), Abney (1987), Grimshaw (1991, 2000)). Ds select for Ns but Ns may project well-formed noun phrases, too, where the only condition on well-formedness is that a nominal projection must be “functionally complete”, i.e. must be [FCOMPL +], which Ds lexically are and Ns may acquire via bare pluralization. My approach has several advantages over Netter’s. First and foremost, the notion of “functional completeness”, which is given no linguistic definition at all, has been replaced with something grounded in uncontroversial observations about semantics (see also Hudson (2000) for a critique of functional categories). Second, the approach outlined above requires a minimal number of extra types (a part-of-speech supertype *nominal* and three extra semantic types above and beyond Ginzburg and Sag (2000), cf. Netter’s extensive type hierarchy) and no additional features (cf. Netter’s SPEC, FCOMPL, N, V, MAJOR, MINOR¹⁴), maybe even eliminating some features (see below). Therefore this approach has both conceptual and technical advantages over Netter’s.

8 Conclusion

The approach to noun phrase structure presented here also has several advantages over the NP approaches common in HPSG. First, looking at the technical advantages from an HPSG point of view, ellipsis is handled naturally (without null elements or category changing rules, cf. Nerbonne et al. (1989)), reducing the heterogeneity of grammatical information. Second, although I did not discuss this explicitly, the reformulation of the subcategorization properties of Ds allows us to eliminate the feature SPEC, used to pass semantic information from Ns to the Ds they take as specifiers in NP theories (Pollard and Sag, 1994). Furthermore, this approach moves us closer to eliminating the SUBJ/SPR distinction, largely motivated by predicative noun phrases which have both D specifiers and NP subjects, since now Ns do not take SPR values.

However, the real advantages to this approach aren’t so much technical, or necessarily empirical, as they are conceptual. First of all, this approach directly incorporates linguistic observations about the categorial relationship between D and N, something that isn’t ruled out in strict headedness approaches but is rarely directly encoded. Second, it makes no unattested categorical claims about noun phrase headedness, contra strict headedness approaches, since the cross-linguistic evidence does not provide a clear motivation for universally selecting either D or N as a head. Third, it paves the way for capturing the similarities between D and Aux, first noted in terms of gapping and ellipsis by Jackendoff (1971) and later in the DP literature following Abney (1987). Perhaps most significantly, this approach paves the way for grounding generalizations about well-formedness entirely in semantics and avoiding unnecessary syntactic operations. This has the nice result that the

¹⁴This SPEC is a boolean feature indicating whether something has picked up its specifier, not to be confused with the SPEC feature which passes semantic information from Ns to Ds in Pollard and Sag (1994).

same kinds of semantic processes can cover a wider range of languages, including those without Ds such as Estonian, Japanese, Russian, Finnish, etc., without positing unmotivated syntactic structure. Finally, this approach has potential to converge with other recent work collapsing the nominal part of speech hierarchy, in particular van Eynde (2003, this volume) and Sag et al. (in progress).

9 Acknowledgments

This paper first developed out of a study of \bar{N} -ellipsis in HPSG, ostensibly a difficulty in a theory without null categories where the N is considered the head. I'd like to thank Ivan Sag and Tom Wasow in particular for their help and guidance in developing these ideas. I'd also like to thank Emily Bender, Joan Bresnan, Luis Casillas, Liz Coppock, Iván García, Dick Hudson, Beth Levin, Stanley Peters, Geoff Pullum, Judith Tonhauser, Arnold Zwicky, and two anonymous reviewers for their help and comments. I'd especially like to thank Itamar Francez for his constant support and also for suggesting the topic to me in the first place (in the form of a challenge). Any errors and omissions in this paper are entirely my own.

References

- Abney, Steve. 1987. *The English Noun Phrase in its Sentential Aspect*. Ph.D. thesis, MIT.
- Barwise, Jon and Robin Cooper. 1981. Generalized quantifiers and natural language. *Linguistics and Philosophy*.
- Chao, Wynn. 1988. *On Ellipsis*. New York: Garland Publishing, Inc.
- Chierchia, Gennaro. 1998. Reference to kinds across languages. *Natural Language Semantics* (6):339–405.
- Chomsky, Noam. 1986. *Barriers*. No. 13 in Linguistic Inquiry Monograph. Cambridge, Mass.: MIT.
- Chomsky, Noam. 1995. *The Minimalist Program*. Cambridge, Mass: MIT Press.
- Copestake, Ann, Dan Flickinger, Ivan Sag, and Carl Pollard. 1999. Minimal recursion semantics: An introduction. <http://www-csli.stanford.edu/~acc/papers/newmrs.ps>.
- Croft, William. 1993. What is a head? In J. Rooryck and L. Zaring, eds., *Phrase Structure and the Lexicon*, pages 35–76. Dordrecht: Kluwer Academic Publishers.
- Dowty, David R., Robert E. Wall, and Stanley Peters. 1981. *Introduction to Montague Semantics*. Dordrecht: Reidel.
- Ginzburg, Jonathan and Ivan A. Sag. 2000. *Interrogative Investigations: The Form, Meaning, and Use of English Interrogatives*. CSLI Publications.
- Grimshaw, Jane. 1991. Extended projections. Unpublished ms., Brandeis Univer-

sity.

- Grimshaw, Jane. 2000. Locality and extended projection. In P. Coopmans, M. Everaert, and J. Grimshaw, eds., *Lexical Specification and Insertion*, pages 115–133. John Benjamins.
- Hankamer, Jorge. 1978. On the nontransformational derivation of some null np anaphors. *Linguistic Inquiry* 9(1).
- Hankamer, Jorge and Ivan Sag. 1976. Deep and surface anaphora. *Linguistic Inquiry* 7(3):391–428.
- Harris, Zellig. 1946. From morpheme to utterance. *Language* 22(3):161–183.
- Hudson, Richard. 1984. *Word Grammar*. Oxford: Basil Blackwell Publisher Limited.
- Hudson, Richard. 1987. Zwicky on heads. *Journal of Linguistics* 23(1):109–132.
- Hudson, Richard. 1990. *English Word Grammar*. Oxford: Basil Blackwell Publisher Limited.
- Hudson, Richard. 2000. Grammar without functional categories. In R. Borsley, ed., *The Nature and Function of Syntactic Categories*. Academic Press.
- Jackendoff, Ray. 1971. Gapping and related rules. *Linguistic Inquiry* 2(1).
- Jackendoff, Ray. 1977. *\bar{X} Syntax: A Study of Phrase Structure*. Cambridge: MIT Press.
- Lascarides, Alex and Ann Copestake. 1999. Default representation in constraint-based frameworks. *Computational Linguistics* 25(1):55–105.
- Longobardi, Giuseppe. 1994. Reference and proper names: A theory of n-movement in syntax and logical form. *Linguistic Inquiry* (25):609–665.
- Montague, Richard. 1974. The proper treatment of quantification in English. In R. Thomason, ed., *Formal Philosophy*, pages 247–270. New Haven: Yale University Press.
- Nerbonne, John, Masayo Iida, and William Ladusaw. 1989. Running on empty: Null heads in head-driven grammar. In E. J. Fee and K. Hunt, eds., *Proceedings of the Eight West Coast Conference on Formal Linguistics*. Stanford: CSLI.
- Netter, Klaus. 1994. Towards a theory of functional heads: German nominal phrases. In J. Nerbonne, K. Netter, and C. Pollard, eds., *German Grammar in HPSG*. Stanford: CSLI.
- Partee, Barbara H., Alice ter Meulen, and Robert E. Wall. 1990. *Mathematical Methods in Linguistics*. Dordrecht: Kluwer Academic Publishers.
- Payne, John. 1993. The headedness of noun phrases: Slaying the nominal hydra.

- In G. G. Corbett, N. M. Fraser, and S. McGlashan, eds., *Heads in Grammatical Theory*, pages 114–139. Cambridge: Cambridge University Press.
- Pollard, Carl and Ivan A. Sag. 1994. *Head-Driven Phrase Structure Grammar*. Chicago, IL: The University of Chicago.
- Postal, Paul. 1966. On so-called ‘pronouns’ in English. In *Georgetown Monographs on Languages and Linguistics*, pages 177–206. Georgetown University Press.
- Radford, Andrew. 1993. Head-hunting: On the trail of the nominal janus. In G. G. Corbett, N. M. Fraser, and S. McGlashan, eds., *Heads in Grammatical Theory*, pages 73–113. Cambridge: Cambridge University Press.
- Ross, John Robert. 1967. *Constraints on Variables in Syntax*. Ph.D. thesis, MIT. Published as *Infinite Syntax!*, Ablex, Norton, NJ, 1986.
- Sag, Ivan A., Charles Fillmore, Paul Kay, and Laura Michaelis. in progress. Some nominal constructions in English. Manuscript.
- Szabolcsi, Anna. 1987. Functional categories in the noun phrase. In I. Kenesei, ed., *Approaches to Hungarian 2*, pages 167–189. Jate Press Szeged.
- van Eynde, Frank. 2003. On the notion ‘determiner’. In S. Müller, ed., *Proceedings of the 2003 HPSG Conference*. Stanford, CA: CSLI Publications.
- Zwicky, Arnold M. 1985. Heads. *Journal of Linguistics* 21(1):1–29.
- Zwicky, Arnold M. 1993. Heads, bases, and functors. In G. G. Corbett, N. M. Fraser, and S. McGlashan, eds., *Heads in Grammatical Theory*, pages 292–315. Cambridge: Cambridge University Press.

Capturing word order asymmetries in English Left-Peripheral Constructions: A Domain-Based Approach

Chan Chung 
Dongseo University

Jong-Bok Kim 
Kyung Hee University

Proceedings of the 10th International Conference on
Head-Driven Phrase Structure Grammar

Michigan State University

Stefan Müller (Editor)

2003

Stanford, CA: CSLI Publications

pages 68–87

Chung, Chan & Jong-Bok Kim. 2003. Capturing word order asymmetries in English Left-Peripheral Constructions: A Domain-Based Approach. In Stefan Müller (ed.), *Proceedings of the 10th International Conference on Head-Driven Phrase Structure Grammar, Michigan State University*, 68–87. Stanford, CA: CSLI Publications. DOI: 10.21248/hpsg.2003.4. 

Abstract

Even though the word order in English is rather straightforward, the distributional possibilities of left-peripheral elements like topic phrases, *wh*-phrases, and negative operators (introducing an SAI) are quite intriguing and complex. In particular, there seems to exist no straightforward way of capturing the linear order asymmetries of these elements in the main and embedded clauses. The prevailing analyses have resorted to movement processes with multiple functional projections. The goal of this paper is to explore an alternative analysis to such movement-based analyses. In particular, this paper adopts the notion of topological fields (DOMAIN) proposed by Kathol (2000, 2001) within the framework of HPSG. The paper shows that within this DOMAIN system, the distributional possibilities as well as the asymmetries we find in English left peripheral constructions can easily follow from the two traditional views: (i) a topic precedes a focus element, and (ii) in English a *wh*-phrase and a complementizer competes with each other for the same position.

Key words: left-peripheral elements, domain, HPSG, *wh*-phrases, topic, negative-operator, focus

1 Basic Facts

1.1 Left Peripheral Elements in the Main Clause

Most of the English speakers we consulted do not allow two consecutive topics or *wh*-phrases in finite root clauses:

- (1) a. *[On the desk], [this book], John put.
- b. *[To whom], [what] should Bill give?.
- c. *What when will you do?

However, when two different kinds of these phrases occur in the left-peripheral positions, the topic needs to precede the *wh*-phrase (Hooper and Thompson 1973, Langendoen 1979, Watanabe 1993, Haegeman 2000):

- (2) a. [This book], [to whom] should Bill give?
 - b. [These prices], [what] can anyone do about?
 - c. [During the vacation], [for what kind of jobs] would you go into the office?
- (3) a. *And [to whom], [a book like this], would you give?
 - b. *[What], [these prices] can anyone do about?
 - c. *[For what kinds of jobs] [during the vacation] would you go into the office? (Baltin 1982)

When a topic occurs with a negative operator that combines with an inverted sentence, the topic also needs to precede the operator (Haegeman 2000):¹

- (4) a. [To John], [nothing] would we give.
 b. [These books], [only with great difficulty] can she carry.
 c. [During the vacation], [on no account] would I go into the office.
- (5) a. *[Nothing], [to John], would we give.
 b. *[Only with great difficulty], [these books], can she carry.
 c. *[On no account] [during the vacation], would I go into the office.

However, the situation is different with a *wh*-phrase. In root clauses, the *wh*-phrase cannot appear together with a negative SAI operator, regardless of its sequential ordering relation with the operator.

- (6) a. *[On which table] [only with great difficulty] would she put the big rock?
 b. *[Only with great difficulty] [on which table] would she put the big rock?

As in (6), neither a *wh*-phrase nor a negative operator can precede the other.

1.2 Left-Peripheral Elements in the Embedded Clause

With respect to the order of left peripheral elements, English embedded clauses differ from root clauses in several respects. One contrast we can find is the ordering relations between *wh* phrases and topic phrases. For example, unlike in root clauses, the *wh*-phrase in embedded clause must precede the topic phrase:²

- (7) a. the man [to whom], [liberty], we could never grant
 b. ?I wonder [to whom] [this book], Bill should give.
 c. I was wondering [for which jobs], [during the vacation], I should go into the office.
- (8) a. *the man [liberty], [to whom] we could never grant
 b. *I wonder [this book], [to whom] Bill should give. (Petssetsky 1989)
 c. *I was wondering, [during the vacation], [for which jobs] I should go into the office.

¹We assign the term ‘negative operator’ for the negative expressions as well as expressions like *only* that combine with an SAI (subject-auxiliary inversion) sentence.

²An outside reviewer of the original abstract points out that there could be cases that appear to violate this ordering restriction:

- (i) a. (??) I’ve always had this sort of attitude that Joe_i, how much_j can you say ___j about ___i?
 b. (??) On the other had, you’re always kind of thinking that Joe_i, what a lot of nice things_j, there are to say ___i about ___j.

In the examples, the topic precedes the *wh*-phrase. Most of the speakers we consulted did not accept these. The embedded clauses here seem to function as exclamative clauses that cannot appear in canonical root clauses. We believe such examples are allowed in highly limited, colloquial contexts with proper phonological prominence.

The positional possibilities of a negative operator are also slightly different: As in root clauses, the negative operator should follow the topic clause as shown in (9) and (10).³

- (9) a. Becky said that [these books], [only with great difficulty], can she carry.
 b. He said that [beans], [never in his life], had he been able to stand.
- (10) a. *He said that [never in his life], [beans], had he been able to stand.
 b. * I promised that [on no account] [during the holidays] will I write a paper. (Haegeman 2000)

However, in embedded clauses, the negative operator can appear with a *wh*-phrase when the operator follows it:

- (11) a. I wonder [on which table] [only with great difficulty] would she put the big rock.
 b. *I wonder [only with great difficulty] [on which table] would she put the big rock.

The embedded clause ordering in (11)b is thus not allowed in the root clause.

The table (12) summarizes what we have observed so far with respect to the ordering relations among left peripheral elements in English.

Sequence	Root clause	Embedded clause
Topic-ph and Wh-ph	OK	*/??
Topic-ph and Neg-Op	OK	OK
(12) Wh-ph and Topic-ph	*	OK
Wh-ph and Negative-op	*	OK
Neg-op and Topic-ph	*	*
Neg-op and Wh-ph	*	*

Though not all, most English speakers exhibit clear contrasts between root and embedded clauses with respect to the positional possibilities of left-peripheral elements. As in (12), when a topic and a *wh*-phrase can cooccur in a root clause, the topic precedes the *wh*-phrase. However, when they cooccur in an embedded clause, the order gets reversed. Another asymmetry observed is that in root clauses, a topic can appear together with a negative operator when the first precedes the latter, whereas a *wh*-phrase and a negative phrase cannot cooccur together at all. They can appear together only in embedded clauses with the sequence of *wh*-phrase and negative operator.

³One thing to note at this point is that an SAI with the negative operator does not occur with a topic phrase in either order:

- (i) a. *Becky said that [these books], [only with great difficulty] she can carry.
 b. *He said that [beans], [never in his life] he had been able to stand.

Numerous attempts have been made to account for the asymmetries we have observed here, but most within the interactions between functional projections and movement processes (e.g, Rizzi 1997, Haegeman 2000, etc). In what follows, we will provide a nonconfigurational analysis that relies on the notion of topological fields developed by Kathol (2000, 2002).

2 Analysis with the Notion of Topological Fields

The theoretical framework that we adopt to account for such asymmetries in English left-peripheral constructions is HPSG (Head-driven Phrase Structure Grammar). In particular, we adopt the word order domain theory developed by Reape (1994) and Kathol (2000, 2001, 2002) for the clausal structures of German. One prominent example Kathol (2000) cites is the complementary distribution of German complementizers and finite verbs:

- (13) a. ob Hans die Zeitung liest
 whether Hans the newspaper reads.
 ‘whether Hans read the newspaper.’
- b. *ob liest Hans die Zeitung
 whether reads Hans the newspaper

As noted here, the presence of the complementizer requires the verb to be in the sentence final position even if in other environments finite verbs can occur clause-initially. Central to Kathol’s analysis is the level of DOMAIN consisting of an ordered list of elements that contain phonological and categorial information. The order domain of the mother category is computed from the information provided by the daughter constituents at each syntactic combination. Each element of a clausal domain is uniquely marked for the region that it belongs to. For example, within the DOMAIN given in the following German complementizers are occur only in [2] whereas finite verbs occur in either in [2] or [4].

- (14) Distributional Constraints (German) (Kathol 2000):
 [1], [2], [3], ...[3], [4], ...[4],

With the general constraint that limits the number of elements that instantiate as [2] to one, Kathol’s analysis takes the complementarity between finite verbs and complementizers as straightforward constraint satisfaction.⁴

Adopting this idea, we here provide an analysis of English left peripheral elements. The table in (15) is the clausal domain we assume for English:

⁴Kathol (2002) also applies this idea into English. For example, he takes English inverted finite auxiliary verbs and complementizers to have the identical index number, capturing the complementarity effects between the two. See Kathol (2002) for details.

	marker field 1	topic field 2	focus field 3
(15) main-cl:		topic	foc (<i>wh</i> & neg-op)
embedded-cl:	comp <i>wh</i>	topic	neg-op

The table in (15) reflects English word order generalizations: a topic phrase precedes a focused element (*wh* & negative operator). The negative operator gets the function of a ‘focus’ operator, triggering the following sentence to be an inverted one.⁵

The only difference from root and embedded clauses is that a *wh*-phrase in embedded clauses competes with a complementizer for the first position.⁶

As in Kathol (2001), we assume that the different topological fields emerge by virtue of the topological number index (from 1 to 3 for the scope of this paper) borne by a domain element. The assignment of the index numbers can be either lexical or constructional. For example, English lexical complementizers including *that* are always assigned to the positional class 1:

$$(16) \left[\begin{array}{l} \text{DOM} \left\langle \left[\begin{array}{l} 1 \\ \text{PHON} \langle \text{that} \rangle \end{array} \right] \right\rangle \\ \text{HEAD } \textit{comp} \end{array} \right]$$

Meanwhile, constructional constraints will impose appropriate index numbers to a topic, a focus, or a *wh*-phrase as the following:⁷

$$(17) \textit{topic-cl:}$$

$$[] \rightarrow \left[\begin{array}{l} \text{DOM} \langle [2] \rangle \\ \text{TOPIC} + \end{array} \right], \mathbf{H} \left[\begin{array}{l} \text{VFORM } \textit{fin} \\ \text{IC} + \\ \text{INV} - \end{array} \right]$$

$$(18) \textit{foc-cl:}$$

$$[] \rightarrow \left[\begin{array}{l} \text{DOM} \langle [3] \rangle \\ \text{WH} +/\text{NEG} + \end{array} \right], \mathbf{H} [\text{IC} +]$$

⁵There exist several commonalities between *wh*-phrases and negative operators, as noted in Rizzi (1999) and Haegeman (2000). They both occupy *A'* positions and combine with inverted sentences. These two, identically licensing negative polarity items, also are in a sense quantificational. Adopting this line of observation and Haegeman (2000), we call these two as focus markers though there remain finer distinctions.

⁶This partly reflects Chomsky & Lasnik’s (1977) Doubly-Filled COMP Filter (DFCF) constraint and can be found in German too. In standard German, a front *wh*-phrase never cooccurs with an overt complementizer. See Kathol (2001: 38).

⁷We assume the existence of *foc(us)*-clause whose subtypes include (direct and indirect) interrogative *wh*-clauses and negative SAI clauses (cf. Ginzburg and Sag 2000). Thus, a *wh*-element will be focus marked either in the inverted or in the first position of non-inverted embedded clauses. The NEG operator construction itself requires its sentence to be inverted as its constructional constraint.

(19) *embed-wh-cl*:

$$[\text{IC } -] \rightarrow \left[\begin{array}{l} \text{DOM } \langle [1] \rangle \\ \text{WH } + \end{array} \right], \quad \mathbf{H}[\text{INV } +]$$

The clausal constructions here are independently motivated for the proper descriptions of English (Ginzburg and Sag 2000). For example, topic clauses in (17) can be built from independent finite clauses ([IC +]), blocking examples like the following:⁸

- (20) a. *John persuaded Bill [the project]_i to finish ___i.
 b. *John tried [the man]_i to kill.

The *foc-cl* in (18) is also required for the obligatory inversion with the negative operator:

- (21) a. At no time would Leslie run for any public office.
 b. *At no time, Leslie would run for any public office.

- (22) a. *In no time would Leslie run for any public office.
 b. In no time, Leslie would run for any public office.

When the expression functioning as a negative operator occurs in the sentence initial position, it should combine with an SAI sentence.⁹

Finally the existence of *embed-wh-cl* in (19) as a subtype of *wh-cl* (cf. Ginzburg and Sag 2000) allows a *wh*-phrase to combine with a noninverted sentence when occurring in embedded clauses. This is one main difference between clauses with a negative operator and embedded *wh*-clauses.¹⁰

With such independently required constructional constraints, the present analysis just introduces a topological index number to each syntactic constituent. The constraint in (17) specifies that a topichood phrase bears the index number 2 whereas the one in (18) tells us that a *wh*-phrase or a negative-operator focused phrase gets the domain index number 3 only if this combines with an SAI sentence. However, when a *wh*-phrase combines with a noninverted sentence, the phrase is assigned to the index number 1. With these quite general and independently motivated constraints on clauses from (17) to (19), the domain indices impose linear sequence constraints on the position classes by means of the linear precedence constraint in (23):

- (23) Topological Linear Precedence Constraint (cf. Kathol 2001):
 $1 < 2 < 3$

⁸The feature IC means independent clause in Ginzburg and Sag 2000.

⁹We thus in a sense assume that the negative operator construction is a subtype of *foc-cl* with this SAI construction.

¹⁰We assume that *wh*-clauses are partitioned into *root-wh-cl* and *embed-wh-cl*, both of which are again classified into *sub-wh-cl* and *non-subj-cl*. See Ginzburg and Sag 2000.

The constraint in (23) will make it possible to directly impose an ordering restriction on signs in an order domain, not just their phonology values.

One could observe that this simple system could provide a straightforward account of the main asymmetries between root and embedded clauses we have observed in section 1. As noted in (2) and (3), we have observed that in root clauses a topic must precede a *wh*-element or a negative operator, but not the other way around. The clausal domain in (15) and the LP (Linear Precedence) constraint in (23) together can easily capture this contrast. For example, the sentence (2)a, repeated here in (24)a, would have the domain order in (24)b:

- (24) a. [This book], [to whom] should Bill give?
 b. $\left[\text{DOM} \left\langle \left[\begin{array}{l} 2 \\ \text{PHON} \langle \text{this book} \rangle \end{array} \right] \left[\begin{array}{l} 3 \\ \text{PHON} \langle \text{to whom} \rangle \end{array} \right], \dots \right\rangle \right]$

(24)b observes all the relevant constraints. However, examples like (3)a, repeated here in (25)a, are simply not licensed since the *wh*-phrase precedes the topic. The domain order in (25)b illustrates this point:

- (25) a. *To whom a book like this would you give?
 b. $\left[\text{DOM} \left\langle \left[\begin{array}{l} 3 \\ \text{PHON} \langle \text{to whom} \rangle \end{array} \right] \left[\begin{array}{l} 2 \\ \text{PHON} \langle \text{a book like this} \rangle \end{array} \right], \dots \right\rangle \right]$

We can also predict that in root clauses, the topic phrase needs to precede the negative operator as we have seen in (4)a, given in (26)a again. The ordering domain of this sentence given in (25)b proves this clearly:

- (26) a. [To John] [nothing] would we give.
 b. $\left[\text{DOM} \left\langle \left[\begin{array}{l} 2 \\ \text{PHON} \langle \text{To John} \rangle \end{array} \right] \left[\begin{array}{l} 3 \\ \text{PHON} \langle \text{nothing} \rangle \end{array} \right], \dots \right\rangle \right]$

When this ordering is reversed as in (5) (e.g., **Nothing, to John, would we give.*) we obtain an undesirable ordering since the topic phrase with the domain index 2 does not precede the negator operator with the index number 3.

The word order of left-peripheral elements in embedded clauses can also be explained straightforwardly. The main difference between root and embedded clauses comes from the fact that the domain index value 1 is assigned to a *wh*-phrase combining with a noninverted sentence as well as to English complementizers like *that*. This reflects the well known competition between complementizers and *wh*-phrases. There is therefore nothing wrong to have the sequence of *wh*-phrase and topic phrase as in the examples (7). We repeat the example here in (27)a and represent its domain order in (27)b (i.e., $1 < 2$):

- (27) a. the man to whom, liberty, we could never grant..
 b. $\left[\text{DOM} \left\langle \left[\begin{array}{c} 1 \\ \text{PHON } \langle \text{to whom} \rangle \end{array} \right] \left[\begin{array}{c} 2 \\ \text{PHON } \langle \text{liberty} \rangle \end{array} \right] , \dots \right\rangle \right]$

However, the examples in (8), one of which is given in (28)a, again are all ruled out since the topic 2 precedes the *wh*-phrase 1. This domain order in (28)b verifies this:

- (28) a. *the man, liberty, to whom, we could never grant..
 b. $\left[\text{DOM} \left\langle \left[\begin{array}{c} 2 \\ \text{PHON } \langle \text{liberty} \rangle \end{array} \right] \left[\begin{array}{c} 1 \\ \text{PHON } \langle \text{to whom} \rangle \end{array} \right] , \dots \right\rangle \right]$

In the same spirit, the present analysis allows examples like (10)a but not those like (10)b, repeated here in (29)a and b, respectively:

- (29) a. Becky said that [these books], [only with great difficulty], can she carry.
 b. *He said that [never in his life], [beans], had he been able to stand.

In both root and embedded clauses, the topic field must precede the negative operator since the former's index value is 2 whereas the latter bears the index value 3 in both clauses. (29)b is thus unacceptable since it violates the LP constraint in (23).

Since in embedded clauses, the *wh*-phrase, combining with a non-inverted sentence, is designated as bearing the index number 1, we can expect cases like (11)a where the *wh*-phrase precedes the negative operator. The sentence (11)a is repeated in (30)a and part of its domain value is given in (30)b. As noticed, the domain index number 1 precedes the domain number 3.

- (30) a. I wonder on which table only with great difficulty would she put the big rock.
 b. $\left[\text{DOM} \left\langle \left[\begin{array}{c} 1 \\ \text{PHON } \langle \text{on which table} \rangle \end{array} \right] \left[\begin{array}{c} 3 \\ \text{PHON } \langle \text{only with great difficulty} \rangle \end{array} \right] , \dots \right\rangle \right]$

To capture the competition for one identical position between a *wh*-phrase and a complementizer in an embedded clause, we adopt the Uniqueness Condition in Kathol (2001) given in (31):¹¹

- (31) Uniqueness Condition (cf. Kathol 2001):
 $i < i$ (where $i = \{1,2,3\}$)

¹¹As noted in Kathol (2001), this condition seems to be rather counterintuitive. However, since no element can precede itself, there couldn't be two elements with the same number index within one DOMAIN.

This condition can easily capture the complementary distribution between a *wh*-phrase and a complementizer in English embedded clauses. English does not allow cases like (32)a simply due to the fact that the two elements *to whom* and *that* here both have the identical topological domain number, as represented in (32)b:

- (32) a. *I don't know [to whom] [that] Bill gave the book.
 b.
$$* \left[\text{DOM} \left\langle \left[\begin{array}{c} 1 \\ \text{PHON} \langle \text{to whom} \rangle \end{array} \right] \left[\begin{array}{c} 1 \\ \text{PHON} \langle \text{that} \rangle \end{array} \right] \dots \right\rangle \right]$$

The constraint in (31) also can rule out examples like (6) where in a root clause we have the sequence of *wh*-phrase and negative operator as repeated here:

- (33) *On which table only with great difficulty would she put the big rock?

Such examples are not allowed simply because by the constructional constraints of the clause types given in (17) and (18), both the *wh*-phrase and the negative operator in the main clause combine with inverted sentences and both are assigned the domain index value 3. This would then violate the Uniqueness Condition.¹²

In addition, the present analysis allows neither two consecutive topics nor *wh*-phrases, whose examples we have already seen in (1). For example, the badness of (1)a, repeated here in (34)a, can easily be seen from the DOMAIN field given in (34)b:

- (34) a. *? On the desk, this book, John put.
 b.
$$* \left[\text{DOM} \left\langle \left[\begin{array}{c} 2 \\ \text{PHON} \langle \text{on the desk} \rangle \end{array} \right] \left[\begin{array}{c} 2 \\ \text{PHON} \langle \text{this book} \rangle \end{array} \right] \dots \right\rangle \right]$$

A crucial assumption of our analysis is that in embedded clauses the *wh*-phrase behaves just like a complementizer in terms of the distributional possibilities (basically similar to traditional observations such as that of Chomsky and Lasnik

¹²As an anonymous reviewer points out, in Old English a *wh*-phrase and a complementizer can occur together.

- (i) a. I wonder which dish that they picked.
 b. They wonder what had John done.
 c. Who did he hope would he see?

In the present framework this implies that in Old English the two elements have different domain index values with the *wh*-phrase preceding the complementizer.

Another point the anonymous reviewer made is about the fact that the complementizer also competes with an inverted auxiliary verb:

- (ii) a. *I wonder which dish that did they pick. b. *Who did he hope that would he see?

The present system follows Kathol's (2002) analysis in which the complementizer and inverted auxiliary verbs are assigned the identical index number. A parallel fact can be found in German too, which basically motivated a DOMAIN analysis for German clausal structures.

(1977)). This assumption can bring us another desirable consequence. In English, topicalization or negative SAI inversion is possible within an embedded clause only when a complementizer like *that* exists (cf. Ginzburg and Sag 2000 and others):

- (35) a. She subtly suggested *(that) [problems of this sort, our analysis would never account for].
 b. They believed *(that) [never again would we have to do housework].

As noted by Ginzburg and Sag (2000), verbs like *suggest* select a nonindependent clause ([IC –]) whose value is originated from the complementizer *that*. Meanwhile, as given in (36)b, the complementizer *that* itself selects a finite S with this IC feature unspecified and as the result generates a nonindependent clause:

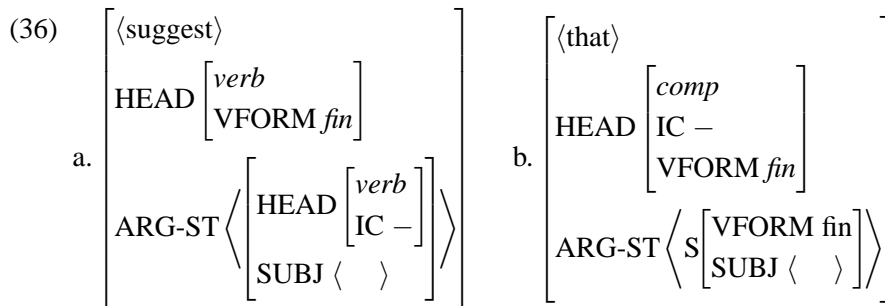

The absence of *that* in (35) thus means the violation of the verb's subcategorization requirements: With the absence of *that*, the verb *suggest* would combine with an inverted independent clause ([IC +]) even though it lexically selects a dependent clause ([IC –]) as given in its lexical specification (36)a.

The negative SAI construction is possible in an embedded clause only when either the complementizer *that* or a *wh*-phrase occupies the initial marker field:

- (37) a. I wonder [on which table] [only with great difficulty] would she put the big rock.
 b. *I wonder [[only with great difficulty] [would she put the big rock on the table]].

Just like the verb *suggest*, we simply need to say that *wonder* select an [IC –] indirect question. (37)b is thus unacceptable since the verb combines with an [IC +] clause: it violates the subcategorization requirements.

One thing to notice here is that, as noted in Culicover (1996), with particular prosodic satisfactions, multiple topics could be possible too:

- (38) a. (??) To that man, liberty, we would never grant.
 b. (??) They told me that to that man, liberty, we would never grant.

To allow such examples, a solution we could adopt is to assume that a context would allow not to apply the Uniqueness Condition in (31) to the topic index '2', hence making the condition apply only to the index values 1 and 3.

There remains one contrast we need to account for: In embedded clauses, two *wh-phrases* can occur when the second one functions as the subject:

- (39) a. We have to figure out which hotels which clients should be assigned to __
.
b. Which man knows where which woman will live? (Pesetsky (1987))

However, in root clauses, two consecutive *wh-phrases* are not possible even if the second one functions as the subject as in (40):

- (40) a. *To whom, who gave the book __ ?
b. *Where which woman will live?

It appears that root and embedded clauses behave differently with respect to the distribution of *wh-phrases*.¹³ In the present system, this asymmetry again follows easily. Since the two *wh-phrases* are both assigned the domain index value '3', the sentences violate the Uniqueness Condition in (31). However, the situation is slightly different in embedded clauses in which the first *wh-* phrase can function as a kind of complementizer with the domain index '1' as we have noticed. This in turn means that *which hotels* in (39)a bears the domain index '1' whereas *which clients* carries the index number '3'. Thus there is no violation of the Uniqueness Condition in embedded clauses.

3 Extraction from an Embedded Clause

Another striking asymmetry is involved with the extraction from a negative SAI sentences. As shown in (41) and (42), the extraction out of the embedded clause is possible only in the negative SAI (Culicover 1991):

- (41) a. *These are the books which Lee says that [only with great difficulty], she can carry __ .
b. These are the books which Lee says that [only with great difficulty], can she carry __ .
- (42) a. *Which books did Lee say that [only with great difficulty], she can carry __ ?
b. Which books did Lee say that [only with great difficulty] can she carry __ ?

One possible way of explaining this asymmetry is to assume that *only with great difficulty* in (41)b and (42)b is a base-generated adjunct modifying the inverted clause, whereas the phrase in (41)a and (42)a is a topicalized phrase. This then can

¹³As an anonymous reviewer pointed out, one could ascribe the ungrammaticality of these sentences to superiority effects.

attribute the unacceptability of (41)a and (42)a to the constraint that nothing can move out of a topic clause. Such a line of approach could get strong support from the scope ambiguity in data like (43) (Rochemont 1986):

- (43) a. [With no job [would John be happy]]. (adjunction)
 b. [[With no job] [John would be happy _]]. (topicalization)

Example (43)a means that there is no job that would make John happy, while (43)b means that John would be happy even without having a job. The scope difference could be captured with the assumption that the PP in (43)a is a base-generated adjunct (having the wide scope) while the one in (43)b is extracted with the narrow scope reading.

However, one difficulty such a base-generated adjunction approach may have is examples like (44) where the operator *not only these books* is a complement:

- (44) a. *[On which table] did Lee say that [these books] [she will put _]?
 b. [On which table] did Lee say that [not only these books [would she put _]]?
 _]?

The base-generated adjunction approach then has to assume that the complement *not only these books* in (44)b is also a phrase adjoined to the SAI, even though it is undoubtedly the complement of the verb *put*. This is quite untraditional wisdom.

We have seen that only the negative SAI operator (combining with an SAI sentence) functions as focus and gets the index number 3, whereas a negative expression combining with a noninverted S is still a topic with the index number 2. The generalizations we can draw from (41) and (42) can be represented as the following:

- (45) a. *XP_i CP[that Topic _ i...]
 b. XP_i CP[that Focus _ i...]

As noted in Rochemont (1989), Culicover (1991), Browning (1996) and others, English seems to observe topic islands when the embedded clause is headed not by a *wh*-phrase rather but by the complementizer *that*. Further data like (46) attest this:

- (46) a. *Which books_i did Lee say [that [on the table]_j she will put _ i _ j]?
 b. *These are the books which_i Lee says [that [to Robin]_j, she will give _ j _ i].

One possible way to tackle such a fact seems to resort to the peculiarities of the complementizer *that* as in *that*-trace effect. In the present context, we interpret this as a constructional constraint on a CP headed by a complementizer as in (47):¹⁴

¹⁴The phrase *cp-topic-cl* is a subtype of *cp-cl* assumed in Ginzburg and Sag (2000).

(47) *cp-top-cl*:

$$\text{CP}[\text{GAP} \langle \quad \rangle] \rightarrow \mathbf{H}[\text{HEAD } \textit{comp}], [\textit{topic-cl}]$$

The constraint in (47) simply tells us that when a *topic-cl* serves as the complement of a complementizer, the resulting CP contains no empty element. This simple constraint is enough to account for the extraction asymmetries provided in (41) and (42). For example, (42)a is unacceptable since the CP clause *[[that][only with great difficulty she can carry _]]* has a nonempty GAP value though as indicated in (46) its GAP value should be empty.

4 Other Alternatives

4.1 Brief Comparison with Configurational Approaches

The prevailing accounts of the ordering restrictions among left peripheral elements have been provided in terms of purely configurational perspectives or constructional properties. The dominant perspective is to posit hierarchical functional projections with the mechanism of movement as set forth by Culicover (1996), Rizzi (1997), Haegeman (2000), among others.

Literature have observed that the possibility of inverting a negative operator in embedded clauses as in (48) makes a single CP analysis unsatisfactory. For example, consider the examples in (48):

- (48) a. She said that on no account would she go there.
 b. *She asked me under what circumstances would I go there.

Since *that* in (48)a occupies the C position, an additional position is required to accommodate the sentence-peripheral constituent *on no account*. In addition (48)b indicates that negative and interrogative inversion both behave differently. One option that Culicover (1991, 1996) has taken is to introduce an independent functional projection PolP as roughly represented in (49):

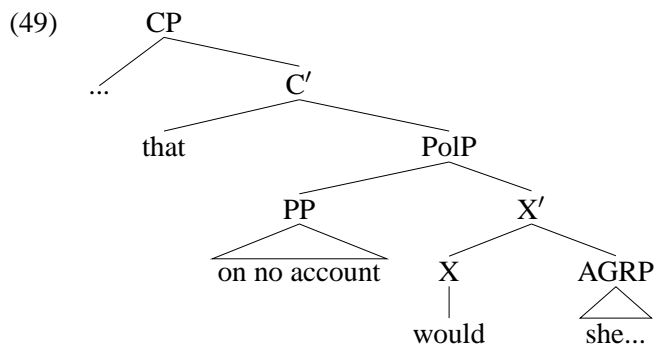

However, as noted earlier, since we have cases with more than one peripheral elements, the postulation of one additional functional projection is not enough:

- (50) a. I promise that [during the holidays] [on no account] will I write a paper.
 b. *I promise that [on no account] [during the holidays] will I write a paper.

The existence of examples like this has led to the accounts that treat embedded topicalization as an operation of XP adjunction to IP (cf. Baltin 1982, Lasnik and Saito 1992, and Rochemont 1986, among others). However, as noted in Haegeman (2000), if topicalization is a simple adjunction to a maximal projection, this adjunction approach would not block examples in (50)b as well as those like (51) at all.¹⁵

- (51) *I promise that on no account will during the holidays I write a paper.

As a way of opening more positions, Rizzi (1997) and Haegeman (2000) have in a sense introduced the ‘Split CP hypothesis’ as roughly represented in (52):

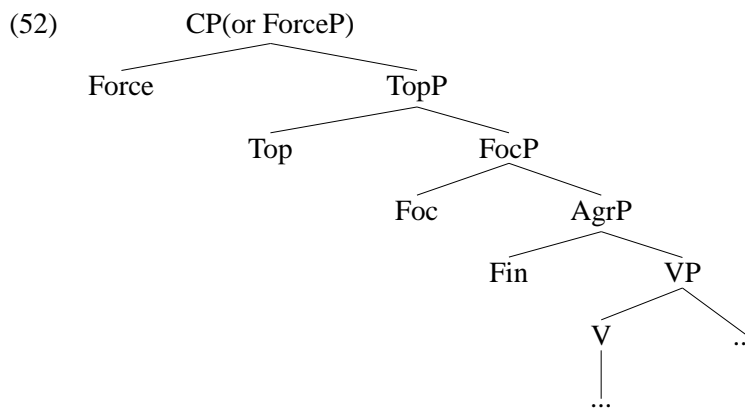

Such a configurational ordering could capture certain ordering constraints between topic and focus together with the head movement triggering criterion given in (53):

- (53) The Wh & Neg Criterion: (Rizzi 1997, Haegeman 2000, Haegeman 2002)
 A *wh*-operator/a neg operator must be in a spec-head configuration with a [+Wh/+neg]-X⁰

Though such a movement-based analysis sketched so far is appealing, it seems to require additional assumptions to account for the positional possibilities among left-peripheral elements as well as the contrast between embedded and root clause asymmetries. The key assumptions that an analysis like that of Haegeman and Guéron (1999) or that of Haegeman (2000) adopts could be summarized as follow (also see Rizzi 1997):

¹⁵If following Chomsky (1986) in which Aux moves to I to C then, forming a CP projection for the negative SAI sentence, a topic phrase like *during the holidays* in (50)a has to be attached not to an IP but to a CP. This then could not account for the presence of *that* here.

- Assumptions for Simple Cases:
 1. Root clause: The *wh*-phrase moves to the SpecCP. The head *wh*-feature is base generated within IP and movement of the tensed Aux to C will create the necessary spec-head configuration in generating sentences like ‘*What will you do about it?*’
 2. Embedded clause: The *wh* feature is base-generated on a head within CP (selected by the matrix predicate). Fronting the *wh*-phrase to the specifier of the relevant head creates the appropriate spec-head relation. This then would generate examples like *I wonder what you will do about it.*¹⁶
- Assumptions for Neg-operator SAI cases
 1. Root clause: The Neg-operator moves to the CP domain and the Aux *did* moves to C, creating the required spec-head relation. This would generate examples like *Not a single paper did he read.*
 2. Embedded clause: Since the embedded negative clauses are not selected by a matrix predicate, the NEG-feature is based generated on T whereas the *wh* feature is generated on C. This will allow cases like *I wonder [on which table] [only with great difficulty] would she put the big rock.*
- Assumptions for complex cases:
 1. Root clauses: Topic moves to SpecTopicP, *wh-ph* moves to SpecFoc, and the Aux to Foc. This would then generate the Topic-Wh phrase sequence as in (54):

(54) a. During the vacation, for what kind of jobs would you go into the office?
 b. During the vacation, on no account would I go into the office.

In addition, a Neg operator and a *wh*-phrase target the same projection, blocking examples like the following:

(55) a. *In no way, why would Robin volunteer?
 b. *Why in no way would robin volunteer.

 2. Embedded clauses: The highest head of the CP (Force) is associated with *wh*, generating the sequence of Wh-Topic as in *I wonder to whom this book Bill should give.* Unlike the *wh* phrase, Neg sentences are not selected: this makes the *wh* phrase targets CP whereas the negative SAI targets FocP. Thus the grammar generates cases like *I wonder on which table only with great difficulty would she put the big rock.*

¹⁶There exists still a need to block Aux from moving to C in embedded clauses.

Even though the assumptions give above, together with the hierarchically organized functional projections and movement operations, can state various distributional properties of left peripheral elements, further elaborations seem to be required if we look into further data. For example, let us consider the following examples:

- (56) a. *To whom would [a book like this] you send?
 b. *Never in my life will, [beans], I eat.
 c. *I stress that on no account will, [during the vacation], I go into the office.
 d. *For which jobs would [during the vacation] you go into the office?
 (Haegeman 2000)

All these examples would observe the Neg or Wh-criterion since the auxiliary verb immediately follows either a *wh*-phrase or a neg-operator. For example, in (56)d, one option would be to assume that the topic *during the vacation* somehow blocks the movement of *would*. However, this is quite unusual in derivational perspectives in which only a lexical element can block movement of a head lexical element. Or one could claim that no feature triggers the auxiliary verb to move. It appears that when more elements are involved in the left-peripheral constructions, additional assumptions are unavoidable: for example, Haegeman and Guéron (1999) introduces the feature TOPIC to the head of TopicP and assume that this feature blocks the head movement of Aux to a higher phrase.

As we have seen, the analysis presented here requires no additional machinery for such cases. Cases like (56) are simply predicted from the independently motivated constructional properties of inverted clauses. Adopting idea of Ginzburg and Sag (2000), we accept the view that English has the construction of *sai-ph* whose constraints are given in (57):

(57) *sai-ph*:

$$[\text{SUBJ } \langle \quad \rangle] \rightarrow \mathbf{H} \begin{bmatrix} \text{INV} + \\ \text{AUX} + \\ \text{SUBJ } \langle \boxed{\text{I}} \rangle \\ \text{COMPS } \boxed{\text{A}} \end{bmatrix}, \boxed{\text{I}}, \boxed{\text{A}}$$

Given this, we can easily see why the examples in (56) are ill-formed: the filler, topic is between the head auxiliary and the subject, which is not licensed by this constraint at all.

We could not do all justice to the derivational analyses here, but it appears to be clear that such analyses require a series of hierarchically-ordered functional projections as well as constraints on the movement operations to generate the acceptable ordering relations among left peripheral elements. Meanwhile, our analysis relying on the notion of topological fields is much simpler in that it just assigns the

domain index numbers to the relevant elements based on not an arbitrary, but common assumptions that (i) topic precedes focus and (ii) in root clauses *wh*-phrases and complementizers positionally compete with each other.

4.2 Lexical and Constructional Constraints

A similar question arises whether lexical properties can tell us all the ordering restrictions among peripheral elements. For example, the *wh* initial position in the embedded clause is independently required since it is selected by the higher verb as represented in the following:

- (58) a. I wonder who John met last night.
 b. *I wonder that John met Bill last night.

However, it seems that constructional constraints are also imposing restrictions on the ordering restrictions. For example, nothing lexically seems to restrict the sequence between a relative *wh*-phrase and a topic phrase as in (59):

- (59) a. the man [to whom] [liberty] we could never grant
 b. *the man [liberty] [to whom] we could never grant.

Even if the relative *wh*-phrase *to whom* is not selected by a head, it should be in the initial position. We could not simply rule out the sequence of Topic and Wh phrase since this is what we find in root clauses as in (60):

- (60) This book, to whom should Bill give?

One could still question that the asymmetries we have discussed here could be followed directly from structural properties of the constructions involved. If we look into the main contrasts between root and embedded clauses in detail which we summarized in (61), we could see that structural properties do not give us all the answers:

	Root clause	Embedded clause
(61) a.	*Wh-ph – Topic – Neg-Op	Wh-ph – Topic – Neg-Op
b.	Topic – Wh-ph	*Topic – Wh-ph
c.	*Wh-ph – Neg-Op	Wh-ph – Neg-Op

One option to capture the contrasts would be to resort to constructional constraints in each case. For example, to capture (61)a, one could assume that in root clauses a *wh*-clause cannot combine with a topic clause. However, this restriction cannot be applied in embedded clauses since there is nothing wrong with this ordering in an embedded clause. We could simply say that in a root clause a *wh-ph* cannot combine with a Neg-operator whereas this is a possible ordering in an embedded

clause. It appears that no structural properties give us reason why English allows the Topic and Wh-phrase only in main clauses whereas the Neg-Op sequence only in embedded clauses, even if part of the distributional properties could follow from the relevant structural properties.

It seems at least to us that such a purely constructional analysis requires a more complicated grammar than the present analysis with the notion of DOMAIN. The point this paper tries to make is that the clear contrasts in the ordering relations of left-peripheral elements between root and embedded clauses are closely related with the tight interactions among various grammatical components including the domain order. That is, lexical, constructional, and topological fields all play their own roles in determining the ordering possibilities of left peripheral elements.

5 Conclusion

The main goal of this paper has been to explore how to analyze the word order asymmetries in the left peripheral constructions under the framework of HPSG. In particular, the distributional possibilities of left-peripheral elements like topic phrases, *wh*-phrases, and negative operators (introducing an SAI) could not be spelled out in a simple manner. This paper has explored a simple way of capturing such intriguing properties by introducing the notion of topological fields (DOMAIN) proposed by Kathol (2000, 2001). This DOMAIN-based approach just needs two traditional views: (i) a topic precedes a focus element, and (ii) in English a *wh*-element and a complementizer competes with each other for a position. The analysis provided here appears to serve as a plausible alternative to movement approaches that rely on movement processes together with multiple functional projections.

References

- Authier, M. 1992. Iterated CPs and embedded topicalization. *Linguistic Inquiry* 23, 329–336.
- Baltin, M. 1982. A landing site for movement rules. *Linguistic Inquiry*, 13: 1–38.
- Browning, Margaret. 1996. CP recursion and *that*-t effects. *Linguistic Inquiry*, 27: 237–256.
- Chomsky, N. 1977. On *wh*-movement, In Adrian Akmajian et al. (eds.), *Formal Syntax*. New York: Academic Press, 71–132.
- Chomsky, N. 1986. *Knowledge of Language*. New York: Praeger.
- Chomsky, N. and Lasnik, H. 1977. Filters and control. *Linguistic Inquiry* 8: 425–504.
- Culicover, P. 1991. Topicalization, inversion, and complementizers in English. OTS Working papers.

- Culicover, Peter. 1993. Evidence against ECP accounts of the *that-t* effect. *Linguistic Inquiry* 24: 557–561.
- Culicover, Peter. 1996. On distinguishing A' movements. *Linguistic Inquiry* 27, 445–463
- Ginzburg, Jonathan and Ivan Sag. 2000. *Interrogative Investigations*. CSLI Publications, Stanford.
- Green, Georgia. 1976. Main clause phenomena in Subordinate Clauses. *Language*, 52: 382–397.
- Haegeman, L. and J. Guéron. 1999. *English Grammar: A Generative Approach*. Blackwell Publishing.
- Haegeman, L. 2000. Inversion, Non-adjacent inversion and adjuncts in CP. *Transactions of the Philological Society*, 98:1, 121–160.
- Haegeman, L. 2002. Negative inversion, the NEG-criterion and the structure of CP. In Larry Horn and Yasuhiko Kato (eds.), *Studies in the Syntax and Semantics of Negation*. Oxford: Oxford Univ. Prss.
- Hooper, J. and S. Thompson. 1973. On the applicability of root transformations. *Linguistic Inquiry* 4: 459–497.
- Kathol, A. 2000. *Linear Syntax*. Oxford: Oxford University Press.
- Kathol, A. 2001. Positional effects in a monostratal grammar of German. *Journal of Linguistics*, 37: 35–66.
- Kathol, A. 2002. A Linearization-based approach to inversion and verb-second phenomena in English. In *Proceedings of the 2002 LSK International Summer Conference Volume II: Workshops on Complex Predicates, Inversion, and OT Phonology*. 223–234.
- Langendoen, T. 1979. More on locative-inversion and structure preserving hypothesis. *Linguistic Analysis* 5. 421–437.
- Lasnik, H. and M. Saito. 1992. *Move α* . Cambridge: MIT Press.
- Pesetsky, D. 1987. Language-particular processes and the earliness principle. Ms. <http://web.mit.edu/linguistics/www/pesetsky.home.htm>.
- Reape, M. 1994. Domain union and word order variation in German. German in Head-Driven Phrase Structure Grammar. CSLI Publications.
- Rizzi, L. 1997. The fine structure of the left periphery. In Haegeman, L. (ed.), *Elements of Syntax: A Handbook in Generate Grammar*. pp. 281–337. Dordrecht: Kluwer Publisher.
- Rochemont, M. 1986. *Focus in Generative Grammar*. John Benjamin.
- Rochemont, M. 1989. Topic islands and the Subjacency parameter. *Canadian Journal of Linguistics*, 34: 145–170.
- Watanabe, A. 1993. AGR-Based Case Theory and Its Interaction with the A-Bar System. *MIT Working Papers in Linguistics*. MIT: Cambridge.

Dealing with optional complements in HPSG-based grammar implementations

Kordula De Kuthy 

Ohio State University

W. Detmar Meurers 

Ohio State University

Proceedings of the 10th International Conference on
Head-Driven Phrase Structure Grammar

Michigan State University

Stefan Müller (Editor)

2003

Stanford, CA: CSLI Publications

pages 88–96

De Kuthy, Kordula & W. Detmar Meurers. 2003. Dealing with optional complements in HPSG-based grammar implementations. In Stefan Müller (ed.), *Proceedings of the 10th International Conference on Head-Driven Phrase Structure Grammar*, Michigan State University, 88–96. Stanford, CA: CSLI Publications. DOI: 10.21248/hpsg.2003.5. 

Abstract This paper discusses how the English Resource Grammar (ERG) captures the optionality of certain complements of verbs based on a single lexical entry coupled with an ontology of markings distinguishing optional from obligatory as well as unrealized from realized elements. Subject-head and head-complement structures are modified accordingly, but due to the lack of a possibility to express and use relational goals in grammars implemented in the LKB system, the ERG encoding falls short of the goal of treating optional complements in a general way. Instead, it requires two new types of ‘auxiliary’ phrases which are otherwise unmotivated. We show that the problem can be overcome by using a recursive relation selecting a member from a list. The use of a lean implementation platform not supporting such relational goals, such as the LKB, thus results in a loss of generality of the grammars that can be expressed, which undermines the closeness of the implemented grammar to current linguistic analyses as one of the hallmarks of HPSG-based grammar implementation. The case study presented in this paper thus supports the position argued in Götz and Meurers (1997) that a system for the implementation of HPSG-based grammars should include both universal implicational principles as well as definite clauses over feature terms.

1 Introduction

The English Resource Grammar (ERG) developed by the LinGO project¹ is a freely available, broad-coverage, HPSG-based grammar of English (Flickinger et al. 2000), which is implemented in the LKB system (Copestake 2002). The grammar contains a wealth of analyses of English phenomena, many of which have not received particular attention in generative linguistics. In this short paper we want to investigate the ERG analysis of optional arguments, an issue with a linguistic basis that is relevant for grammar implementation in general. Based on a discussion of the treatment of optionality proposed in Flickinger (2000) and how it was implemented in the ERG, the paper is intended to contribute to a discussion of the choices involved in implementing HPSG analyses, and how those choices are determined by the options for expressing grammars in a given implementation platform.

2 Optional complements and their treatment in the ERG

In a paper discussing grammar writing techniques intended to improve the efficiency of processing with such grammars, Flickinger (2000) includes a sketch of a proposal for the analysis of verbs with optional complements. The empirical issue is illustrated by the sentences in (1).

¹<http://lingo.stanford.edu/>

- (1) a. Kim bet Tom five dollars that they hired Cindy.
 b. Kim bet Tom five dollars.
 c. Kim bet Tom that they hired Cindy.
 d. Kim bet five dollars that they hired Cindy.
 e. Kim bet five dollars.
 f. Kim bet that they hired Cindy.
 g. Kim bet Tom.
 h. Kim bet.

In sentence (1a), the verb *bet* takes a subject *Kim* and three complements, the NPs *Tom* and *five dollars*, as well as the sentential complement *that they hired Cindy*. The other sentences in (1) exemplify that each of those three complements is optional. In (1b)–(1d) one of the complements is missing, in (1e)–(1g) two complements are missing, and in (1h) none of the complements of *bet* are realized.

The brute-force method for licensing these structures would be to posit eight independent lexical entries for *bet*, one for each of the environments exemplified above. But this would miss the generalization that *bet* has three complements, each of which can be realized or not. Following Flickinger (2000), the ERG takes this generalization into account and posits only the single lexical entry shown in figure 1.² The key aspect here is the specification of the complement requirements

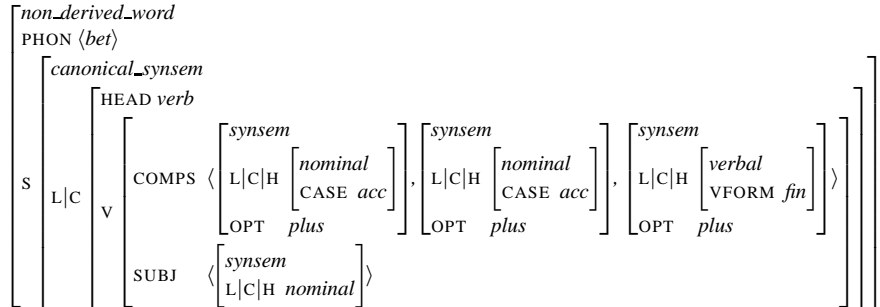

Figure 1: Lexical entry for *bet*

on the COMPS list. The list contains three elements, each of which is marked as optional with the help of an attribute OPT(IONAL) appropriate for *synsem* objects.

In figure 2 on the next page we see the structure that is licensed for a sentence in which none of the optional complements are realized, i.e., sentence (1h). The entry of *bet* can construct as the head daughter of a head-subject phrase even though it has not yet realized its complements. This is possible since, different from the traditional HPSG analysis (Pollard and Sag 1994), the head daughter is not required to be saturated, i.e., have a COMPS value of type *e_List*. Instead, the COMPS value of the head daughter is required to be of type *o_List*, which is a (potentially empty)

²Here and in the following figures, only the specifications relevant to the issue of optionality are shown. For space reasons, attribute names are sometimes abbreviated by their first letter.

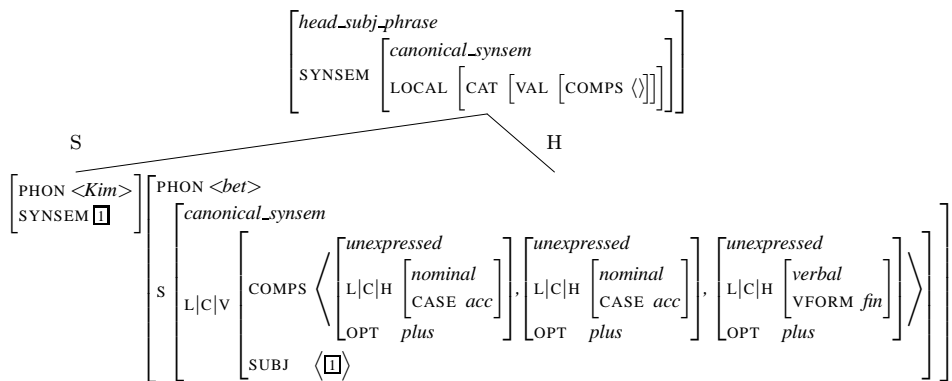

Figure 2: A sentence with three unrealized complements

list of elements, all of which are optional ([OPT plus]) and *unexpressed*; the relevant type constraint and parts of the list hierarchy are shown in figure 3.

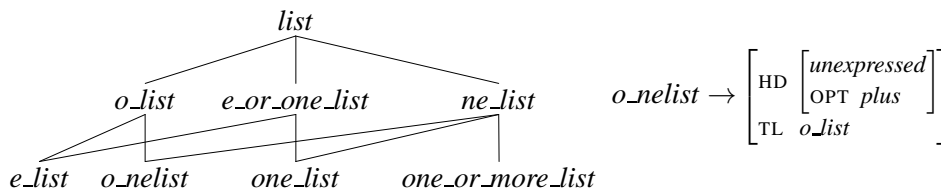

Figure 3: Introducing and constraining the *o_nelist* subtype

In plain words, a sign is understood to be saturated for complements if it either has discharged all its complement requirements (the traditional requirement) or has only optional complement requirements left, which are marked as *unexpressed*.

Adding head-complement phrases to the picture, one can also license (1b) and (1g), which are sentences in which one or two complements are realized and the other complements, which are more oblique than the ones that are realized, are missing.³ Figure 4 shows the relevant aspects of the definition of head-complement phrases in the ERG. Note that it is always the first element of the COMPS list that is realized as the *non_head_dtr* of such a phrase.

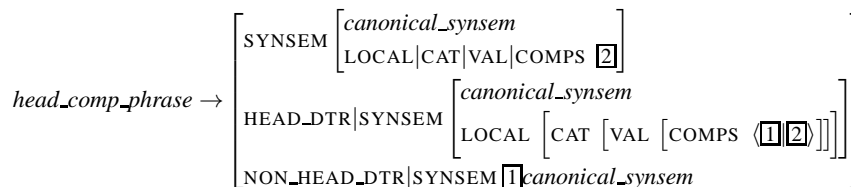

Figure 4: The realization of COMPS requirements in the head-complement rule

³The COMPS is ordered by obliqueness, with the least oblique complement being the first element.

Exemplifying the two types of phrases we have discussed so far, figure 5 shows the structure that the ERG assigns to the sentence (1g).

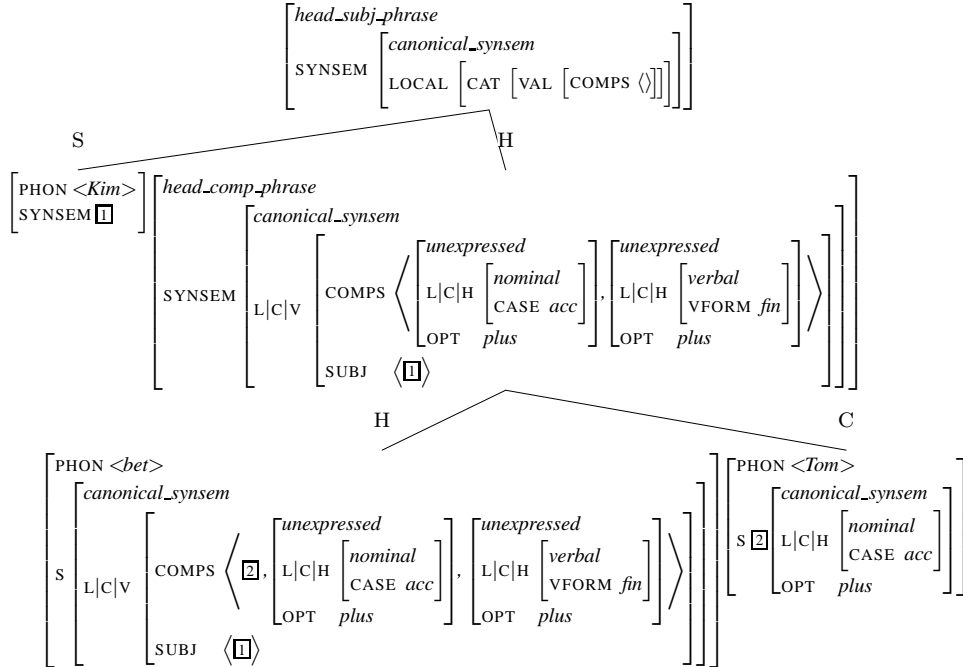

Figure 5: A sentence in which the two most oblique complements are not realized

The lower tree is an instance of a *head_comp_phrase*, in which the first sub-categorization requirement on COMPS, namely the NP *Tom* bearing the tag [2], is realized. The *head_subj_phrase* on top is licensed just as in the previous example, marking the remaining optional elements on the COMPS list of the head daughter *bet Tom* as unexpressed.

Since the *head_comp_phrase* in the ERG always realizes the first element of the COMPS list, a problem arises if one wants to license a sentence in which the least oblique complement, i.e., the first element on the COMPS list is optional and not realized. Note that this is not an accidental oversight in the formulation of the rule licensing *head_comp_phrases* in the ERG; rather it is a consequence of the fact that the LKB system does not support relational goals as attachment to phrase structure rules. In HPSG linguistics such relational goals are used extensively, most prominently to concatenate valence or phonology lists using the append relation, which in the AVN notation is often specified using the \oplus infix-operator. We will see in the next section that when such relational goals are included in the expressive means available to the grammar writer, one can express the proper generalization for the optional argument case: the *head_comp_phrase* realizes the first requirement on COMPS which is not marked as unrealized optional element. In the ERG as implemented in the LKB system, the problem is addressed by introducing

requirement, an unexpressed optional object NP, in order to bring the requirement $\boxed{2}$ to the front of the COMPS list. That complement (*five dollars*) is then realized in the *head_comp_phrase* dominating the *head_opt_comp_phrase*.

2.1 Capturing the missed generalization

We saw above that the ERG analysis of optional complements requires three different head-complement rules since in the LKB system, in which this grammar is implemented, there is no way to express the relevant generalization: that one wants to realize the first element on the COMPS list that is not an optional argument marked as unrealized. The revised *head_complement* rule in figure 7 shows how the intended generalization can be expressed using an append relation (\oplus) to state that the element $\boxed{1}$ to be realized can be preceded by an *o_list*, i.e., a list of unrealized optional elements.

$$head_comp_phrase \rightarrow \left[\begin{array}{l} \text{SYNSEM} \left[\begin{array}{l} canonical_synsem \\ \text{LOCAL|CAT|VAL|COMPS } \boxed{2} \end{array} \right] \\ \text{HEAD_DTR|SYNSEM} \left[\begin{array}{l} canonical_synsem \\ \text{LOCAL|CAT|VAL|COMPS } o_list \oplus (\boxed{1}\boxed{2}) \end{array} \right] \\ \text{NON_HEAD_DTR|SYNSEM } \boxed{1} canonical_synsem \end{array} \right]$$

Figure 7: Generalized COMPS realization in a revised head-complement rule

In a grammar including this revised *head_complement_phrase* instead of the original one from the ERG we saw in figure 4, the types and definitions for *head_opt_comp_phrases* and *head_opt_two_comp_phrases* are no longer needed.

Interestingly, the LKB encoding of the ERG using a *head_complement_phrase* plus the two ‘auxiliary’ phrase types that unearth the first realized complement requirement can be seen as the result of unfurling the first three calls to the append (\oplus) relation in the revised *head_complement_phrase* defined in figure 7, i.e., the LKB encoding can result from a compilation step taking the more general encoding as its input. This means that the issue of enabling the grammar writer to express the full generalization with the recursive relation in the English grammar is independent of the question of the relative efficiency of parsing systems with and without run-time support for relational goals.

3 Summary

This paper investigated the issue of optional arguments in the ERG, the largest HPSG-based grammar for English currently available, and an excellent collection of analyses of many aspects of English syntax that deserves to be documented and discussed to further progress. Such a discussion is particularly relevant given that, as argued by Copestake and Flickinger (2000), one of the hallmarks distinguishing the ERG from other grammar implementation efforts such as those around the

Alvey Natural Language Tools (Briscoe et al. 1987) is its connection to HPSG as an active linguistic framework.

The discussion of the ERG analysis of optional arguments in this paper showed how the ERG captures the optionality of arguments through the use of a single lexical entry coupled with an ontology of markings distinguishing optional from obligatory as well as unrealized from realized elements. Subject-head and head-complement structures are modified accordingly, but due to the lack of a possibility to express relational attachments to phrase structure rules in grammars implemented in the LKB system, the ERG analysis falls short of the goal of treating optional arguments in a general way. Instead, it requires two new types of ‘auxiliary’ phrases which are otherwise unmotivated. The focus on a very lean system without relational goal attachments to phrase structure rules thus results in a loss of generality of the grammars that can be expressed, which undermines the closeness of the ERG to linguistic theory as one of its key aspects. We showed that the problem can be overcome when recursive relations are added to the expressive means available to the grammar writer. This supports the position argued in Götz and Meurers (1997) that a system for the implementation of HPSG-based grammars should include both universal implicational principles as well as definite clauses over feature terms. A further case study which makes precise in what sense such a setup supports more modular, transparent, and compact grammars can be found in Meurers et al. (2003).

The revised treatment of optionality proposed in this paper is part of an ongoing reimplementations of the ERG in the TRALE system (Meurers et al. 2002).⁴

References

- Briscoe, Ted, Claire Grover, Bran Boguraev and John Carroll (1987). A formalism and environment for the development of a large grammar of English. In *Proceedings of the 10th International Joint Conference on Artificial Intelligence (IJCAI-87)*. Milan, Italy.
- Copestake, Ann (2002). *Implementing Typed Feature Structure Grammars*. Stanford, CA: CSLI Publications.
- Copestake, Ann and Dan Flickinger (2000). An open source grammar development environment and broad-coverage English grammar using HPSG. In Maria Gavrilidou, George Carayannis, Stella Markantonatou, Stelios Piperidis and Gregory Steinhauer (eds.), *Proceedings of the Second International Conference on Language Resources and Evaluation (LREC-00)*, Athens.
- Flickinger, Dan (2000). On building a more efficient grammar by exploiting types. *Natural Language Engineering* 6(1), 15–28.
- Flickinger, Dan, Ann Copestake and Ivan A. Sag (2000). HPSG Analysis of English. In Wolfgang Wahlster (ed.), *VerbMobil: Foundations of Speech-to-Speech Translation*, Berlin: Springer, Artificial Intelligence, pp. 254–263.

⁴<http://www.sfs.uni-tuebingen.de/hpsg/sysen.html>

- Götz, Thilo and Walt Detmar Meurers (1997). Interleaving Universal Principles and Relational Constraints over Typed Feature Logic. In *Proceedings of the 35th Annual Meeting of the ACL and 8th Conference of the EACL*. Madrid, pp. 1–8. <http://ling.osu.edu/~dm/papers/acl97.html>.
- Hinrichs, Erhard W. and Tsuneko Nakazawa (1994). Linearizing AUXs in German Verbal Complexes. In John Nerbonne, Klaus Netter and Carl Pollard (eds.), *German in Head-Driven Phrase Structure Grammar*, Stanford, CA: CSLI Publications, no. 46 in CSLI Lecture Notes, pp. 11–37.
- Meurers, W. Detmar, Kordula De Kuthy and Vanessa Metcalf (2003). Modularity of grammatical constraints in HPSG-based grammar implementations. In *Proceedings of the ESSLLI '03 workshop "Ideas and Strategies for Multilingual Grammar Development"*. Vienna, Austria. <http://ling.osu.edu/~dm/papers/meurers-dekuthy-metcalf-03.html>.
- Meurers, W. Detmar, Gerald Penn and Frank Richter (2002). A Web-based Instructional Platform for Constraint-Based Grammar Formalisms and Parsing. In Dragomir Radev and Chris Brew (eds.), *Effective Tools and Methodologies for Teaching NLP and CL*. pp. 18–25. <http://ling.osu.edu/~dm/papers/acl02.html>.
- Pollard, Carl and Ivan A. Sag (1994). *Head-Driven Phrase Structure Grammar*. Chicago, IL: University of Chicago Press.

The secret life of focus exponents, and what it tells us about fronted verbal projections

Kordula De Kuthy 

Ohio State University

W. Detmar Meurers 

Ohio State University

Proceedings of the 10th International Conference on
Head-Driven Phrase Structure Grammar

Michigan State University

Stefan Müller (Editor)

2003

Stanford, CA: CSLI Publications

pages 97–110

De Kuthy, Kordula & W. Detmar Meurers. 2003. The secret life of focus exponents, and what it tells us about fronted verbal projections. In Stefan Müller (ed.), *Proceedings of the 10th International Conference on Head-Driven Phrase Structure Grammar, Michigan State University*, 97–110. Stanford, CA: CSLI Publications. DOI: 10.21248/hpsg.2003.6. 

Abstract The paper investigates a complex word order phenomenon in German and the interaction of syntax and information structure it exemplifies: the occurrence of subjects as part of a fronted non-finite constituent and particularly the so-called definiteness effect excluding (many) definite subjects from this position. We explore the connection between focus projection and the partial fronting cases and show that it is the subject of those verbs which allow their subject to be the focus exponent that can be included as part of a fronted verbal constituent. In combination with the observation by Webelhuth (1990) that fronted verbal constituents need to be focused, this provides a natural explanation of the definiteness effect in terms of the information structure requirements in these sentences. Interestingly, the generally ignored exceptions to the definiteness effect are predicted by our analysis; we show that they involve definite noun phrases which can bear focus, which allows them to be part of a fronted verbal constituent. Finally, building on the integrated grammatical architecture provided in De Kuthy (2002), we formulate an HPSG theory which captures the interaction of constraints from syntax, information structure and intonation.

1 The phenomenon

Haider (1982, p. 13), Kratzer (1984, p. 45), and Grewendorf (1989, p. 23) observed that in German it is possible for ergative verbs to realize a subject as part of a fronted non-finite verbal constituent. This is exemplified in (1).

- (1) a. [Ein Fehler unterlaufen] ist meinem Lehrer noch nie.
an_{nom} error crept in is my teacher still never
 ‘So far my teacher has never made a mistake.’
- b. [Haare wachsen] können ihm nicht mehr.
hair_{nom} grow can him not anymore
 ‘His hair cannot grow anymore.’

Haider (1990) observed that this option also exists for unergative verbs, which is illustrated by (2).¹

- (2) [Ein Außenseiter gewonnen] hat hier noch nie.
an_{nom} outsider won has hier still never
 ‘An outsider has never won here yet.’

¹Grewendorf (1989, pp.192f) also mentions Toman (1986) with an example in which a subject has been fronted with an unergative verb.

- (i) ?[Eine Lösung gefehlt] hat uns schon lange
a_{nom} solution lacked has us_{dat} already for a long time
 ‘We have lacked a solution for a long time already.’

Nevertheless, the occurrence of subjects as part of a fronted non-finite constituent exhibits a number of restrictions. Meurers (2000, ch. 10) pointed out that the option is only available for subjects of raising verbs:

- (3) a. [Ein Außenseiter zu gewinnen] scheint hier eigentlich nie.
a_{nom} outsider to win seems here actually never
 ‘An outsider never actually seems to win here.’
- b. * [Ein Außenseiter zu gewinnen] versuchte hier noch nie.
a_{nom} outsider to win tried here actually never
 ‘An outsider never actually tried to win here.’

Kratzer (1984, p. 46), Grewendorf (1989, p. 24), and Haider (1990, p. 96) mention a definiteness effect disallowing definite subjects from occurring in this construction, an effect which has also received attention in the more recent literature (cf., e.g., Wurmbrand 2001). Using definite subjects for the sentences (1a) and (2) thus results in the ungrammatical sentences in (4).

- (4) a. * [Dieser Fehler unterlaufen] ist meinem Lehrer noch nie.
 this_{nom} error crept in is my teacher still never
 ‘So far my teacher has never made a mistake.’
- b. * Der Außenseiter gewonnen hat hier noch nie.
 the outsider won has here still never

There are, however, some clear counterexamples to this definiteness effect, which are rarely noted² and are not accounted for by any analysis we know of. Some examples are shown in (5).

- (5) a. Das Herz geklopft und geschaudert hat dem Kind. (Wegener 1990, p. 98)
 the heart beaten and shuddered has the child
 ‘The child’s heart beat and it shuddered.’
- b. Die Hände gezittert haben ihm diesmal nicht. (Höhle 1997, p. 114)
 the hands trembled have him this time not
 ‘This time his hands didn’t tremble.’
- c. Das Telefon geklingelt hat hier schon lange nicht mehr.
 the telephone rang has here yet long not anymore
 ‘The telephone hasn’t been ringing here in a long time.’

In this paper, we want to discuss and explore an exciting parallelism between the restriction on what can be fronted as part of a non-finite verbal projection and the properties of focus projection in German. We will argue that the definiteness

²E.g., in fn. 88 on p. 283 of Müller (2002).

effect should be viewed as reflecting the information structure requirements in such sentences, instead of stipulating it as a syntactic constraint—and we will see that the apparent counter-examples are predicted under such an information structure-based approach.

2 Information structure

German is a so-called intonation language in which focused constituents are signaled by pitch accent (cf., Féry 1993). The syllable bearing the pitch accent is called the *focus exponent*. Only one syllable is stressed by a pitch accent, but through *focus projection* larger parts of a sentence can be focused.

2.1 Focus projection and its connection to fronting

As illustrated in (6), the focus exponent in an all-focus sentence normally is one of the arguments of the main verb, but not the subject (Stechow and Uhmman 1986).³

(6) Was ist denn hier für eine Aufregung? / What's all the excitement about?

- a. [[Ein Politiker hat das VOLK belogen.]]_F
a_{nom} politician has the people lied to
- b. # [[Ein POLITIKER hat das Volk belogen.]]_F
a_{nom} politician has the people lied to

Interestingly, as discussed by Grewendorf (1989) and Uhmman (1991, p. 199ff.), in certain cases the subject *can* be the focus exponent. In addition to ergative subjects (7), this is also the case for the subjects of many intransitive unergative verbs (8).

(7) Was ist denn hier für eine Aufregung? / What's the matter here?

- a. [[Dem Präsidenten ist ein FEHLER unterlaufen.]]_F
the president is a mistake crept in
‘The president made a mistake.’

(8) Was ist denn hier für ein Lärm? / What's all the noise about here?

- a. [[Ein HUND bellt.]]_F
a dog barks
- b. [[Ein KIND weint.]]_F
a child cries

Connecting this state of affairs to the issue of fronted verbal constituents we started with, one makes an important observation: The examples (9)–(11) show that it is the subject of those verbs which allow their subject to be the focus exponent that can be included as part of a fronted verbal constituent.

³We write the word that bears the pitch accent in capital letters and mark the entire focus domain with [...]_F. Sentences which are not felicitous under the given context are marked with #.

- (9) a. # [[Ein POLITIKER hat das Volk belogen.]]_F
 a_{nom} politician has the people lied to
 b. * [Ein Politiker belogen] hat das Volk noch nie.
 a politician lied has the people still never
- (10) a. [[Ein HUND bellt.]]_F
 a_{nom} dog barks
 b. [Ein Hund gebellt] hat hier noch nie.
 a dog barked has here yet never
- (11) a. [[Dem Präsidenten ist ein FEHLER unterlaufen.]]_F
 the_{dat} president is a_{nom} mistake crept in
 b. [Ein Fehler unterlaufen] ist dem Präsidenten bisher noch nie.
 an error crept in is the president so far still never

This observation turns out to be a rediscovery: In a surprisingly neglected paper discussing evidence for a VP-constituent in German, Webelhuth (1990, p. 53) connects the issue of focus projection to the issue of subjects as part of fronted non-finite constituents. He claims that the fronted constituent can only contain dependents which are capable of projecting focus. This general claim is only substantiated with one example pair, though, and unfortunately seems to have been overlooked by the later literature.

Webelhuth (1990, p. 53) concludes that “we can explain these facts if we assume that a topicalized constituent containing a verb has to be focused” and relates this to a claim by Grewendorf (1989, p. 194, pp. 219f).⁴ In order to illustrate Webelhuth’s claim let us take a look at some focus-background structures of sentences with a fronted verbal projection. The question-answer pair (12) shows that a fronted verbal projection can be in the focus of an utterance.

- (12) Was ist hier noch nie passiert? / What has never happened here?

 [[[Ein AUSSENSEITER gewonnen]]]_F hat hier noch nie.
 an outsider won has here yet never

The examples (13) and (14) show, that it is not sufficient for part of the fronted verbal projection to be the focus.

- (13) Was ist hier noch nie einem Außenseiter passiert? / What has never happened to an outsider?

 # [Ein Außenseiter [[GEWONNEN]]]_F hat hier noch nie.

⁴Close reading reveals that Grewendorf (1989) apparently did not realize the full generality of the connection between focus projection and fronting in that he restricts it to ergative and theme verbs, explicitly excluding agentive subjects such as the one in Webelhuth’s example (i).

- (i) [Leute getanzt] haben hier noch nie.
 people danced have here never

(14) Wer hat hier noch nie gewonnen? / Who has never won here?

[[Ein AUSSENSEITER]_F gewonnen] hat hier noch nie.

The three examples thus support Webelhuth's claim that a fronted verbal projection has to be focused. Webelhuth's conclusion leaves open whether the fronted verbal projection can also be part of a larger focus. This is tested in (15).

(15) Was ist denn hier für eine Aufregung? / What's all the excitement about?

[[Ein AUSSENSEITER gewonnen] hat hier noch nie]_F

The fact that the answer is infelicitous in such an all-focus context shows that only the fronted verbal constituent must be focused, not more.

2.2 The definiteness effect

We are now ready to return to the definiteness effect and the counter-examples from the beginning of this paper. We saw that many definite subjects cannot be part of a fronted verbal projection (4), whereas other definite subjects can (5). The pattern becomes transparent when one considers the focus projection possibilities in these examples: Example (16a) and (17a) show that in the sentences disallowing the fronting, the subject cannot be the focus exponent, whereas it can be the focus exponent in the second class of sentences, (16b) and (17b).

(16) Was ist denn hier für eine Aufregung? / What's the matter here?

a. # [[Dem Präsidenten ist schon wieder dieser FEHLER unterlaufen.]]_F
the president is yet again this mistake crept in

b. [[Dem Präsidenten zittern die HÄNDE.]]_F
the president tremble the hands

(17) Was ist denn hier für ein Lärm? / What's all the noise here?

a. # [[Der AUSSENSEITER gewinnt.]]_F
the outsider wins

b. [[Das TELEPHON klingelt.]]_F
the telephone rings

The last missing ingredient of an information-structure based explanation for the definiteness effect and its exceptions is a categorization of definite NPs in terms of their discourse potential. De Kuthy (2002, sec. 6.5) discusses that one can distinguish definite NPs which function anaphorically and thereby have to be part of the background of a sentence from a second class of definite NPs which are used deictically, endophorically or as a semantic definite.⁵ This second class can occur as the focus of a sentence. A closer look at the examples where the subject can be the

⁵Following Löbner (1985), we use *semantic definite* to refer to cases where the definite article is combined with a noun that represents a concept that necessarily only applies to one object, such as *the weather*, *the moon*, *the president*, or body parts like *the heart*.

focus exponent, (16b) and (17b), shows that the definite NPs in those sentences are indeed instances of semantic definites. In conclusion, given Webelhuth’s generalization that a fronted verbal constituent has to be focused, such a constituent can only contain those definite subjects that can be a focus exponent, namely definite NPs which are used deictically, endophorically or as a semantic definite.

3 An HPSG analysis

We couch our analysis in the encoding of information structure in HPSG developed in De Kuthy (2002, sec. 6.6). Her approach builds on the proposal of Engdahl and Vallduví (1996) in which a focus-background structure for every sentence is build up compositionally from the focus-background structures of its subparts.

The information structure is encoded in the attribute INFO-STRUC that is appropriate for signs and has the appropriate features FOCUS and TOPIC, with lists of so-called meaningful expressions (semantic terms, cf. Sailer 2000) as values. The background of a sentence in De Kuthy’s approach is defined to be that part of the logical form of the sentence which is neither in focus nor in topic. This characterization of background closely resembles the definition of background employed by the so-called *structured meaning* approaches to focus of Stechow (1981), Jacobs (1983), or Krifka (1992). The INFO-STRUC value of a simple sentence with the focus as indicated in (18) is thus structured as shown in figure 1.

- (18) Peter \llbracket liest ein BUCH. \rrbracket_F
 Peter reads a book

$$\left[\begin{array}{l} \text{S|LOC|CONT|LF } \exists x[\text{book}'(x) \wedge \text{read}'(p, x)] \\ \text{INFO-STRUC } \left[\begin{array}{l} \text{FOCUS } \langle \lambda y \exists x[\text{book}'(x) \wedge \text{read}'(y, x)] \rangle \\ \text{TOPIC } \langle \rangle \end{array} \right] \end{array} \right]$$

Figure 1: A sign representation including information structure

The phonology of signs is altered as shown in figure 2 to include an ACCENT attribute to encode whether a word receives an accent or not, and whether it is a rising or a falling accent in case it receives one.⁶

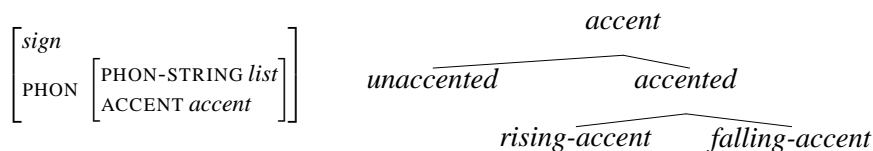

Figure 2: Representing pitch accents

The information structure of words is defined through the principle shown in

⁶The ACCENT attribute is sufficient for the present context; a more developed representation of intonation is left for future research.

figure 3 which assigns the semantic contribution of the word to the focus or topic specification in the information structure representation of that word, depending on the type of accent the word receives.

$$\begin{aligned}
word &\rightarrow \left[\begin{array}{l} \text{PHON|ACCENT } \textit{falling-accent} \\ \text{SS|LOC|CONT|LF } \boxed{1} \\ \text{INFO-STRUC } \left[\begin{array}{l} \text{FOCUS } \langle \boxed{1} \rangle \\ \text{TOPIC } \langle \rangle \end{array} \right] \end{array} \right] \\
&\vee \left[\begin{array}{l} \text{PHON|ACCENT } \textit{unaccented} \\ \text{INFO-STRUC } \left[\begin{array}{l} \text{FOCUS } \langle \rangle \\ \text{TOPIC } \langle \rangle \end{array} \right] \end{array} \right] \\
&\vee \dots
\end{aligned}$$

Figure 3: Relating intonation and information structure

The final component of the theory is a principle specifying the information structure representation of a phrase based on that of its daughters.⁷ Figure 4 shows the focus projection principle of De Kuthy (2002), which covers the case in which focus is not projected and focus projection in the nominal domain.⁸

$$\begin{aligned}
phrase &\rightarrow \left[\begin{array}{l} \text{INFO-STR|FOCUS } \boxed{1} \oplus \textit{collect-focus}(\boxed{2}) \\ \text{HEAD-DTR|INFO-STR|FOCUS } \boxed{1} \\ \text{NON-HEAD-DTRS } \boxed{2} \end{array} \right] \\
&\vee \left[\begin{array}{l} \text{PHON|PHON-STR } \boxed{1} \oplus \boxed{2} \\ \text{SS|LOC } \left[\begin{array}{l} \text{CAT|HEAD } \textit{noun} \vee \textit{prep} \\ \text{CONT|LF } \boxed{3} \end{array} \right] \\ \text{INFO-STR|FOCUS } \langle \boxed{3} \rangle \\ \textit{any-dtr} \left(\left[\begin{array}{l} \text{PHON|PHON-STR } \boxed{2} \\ \text{SS|L|CONT|LF } \boxed{4} \\ \text{INFO-STR|FOCUS } \langle \boxed{4} \rangle \end{array} \right] \right) \end{array} \right] \\
&\vee \dots
\end{aligned}$$

Figure 4: Focus projection in the nominal domain

⁷We assume that information structure is interpreted only for unembedded signs; the value of the INFO-STRUC attribute on subconstituents only serves a local bookkeeping function, similar to features like SLASH or REL in traditional HPSG (Pollard and Sag 1994).

⁸The presentation differs from that in De Kuthy (2002). Definitions of the auxiliary relations:

$$\begin{aligned}
\textit{any-dtr}(\boxed{1}) &:= [\text{HEAD-DTR } \boxed{1}]. \\
\textit{any-dtr}(\boxed{1}) &:= [\text{NON-HEAD-DTRS } \textit{element}(\boxed{1})]. \\
\textit{collect-focus}(\langle \rangle) &:= \langle \rangle. \\
\textit{collect-focus}(\langle \langle [\text{INFO-STRUC|FOCUS } \langle \boxed{1} \rangle] \boxed{2} \rangle \rangle) &:= \langle \boxed{1} \mid \textit{collect-focus}(\boxed{2}) \rangle.
\end{aligned}$$

The first disjunct in the consequent of the principle covers the base case in which the focus does not project further—the mother of the phrase just collects the focus values of all her daughters. The second disjunct covers focus projection in the nominal domain, where focus always projects from the rightmost daughter of a phrase. Note how focus is encoded: If a constituent is part of the focus then its logical form is token identical to an element of its FOCUS value.⁹

For the verbal domain, the regularities are known to be influenced by a variety of factors, such as the word order and lexical properties of the verbal head (cf., e.g., Stechow and Uhmman 1986). Since verbs need to be able to lexically mark which of their arguments can project focus when they are accented, we introduce the boolean-valued feature FOCUS-PROJECTION-POTENTIAL (FPP) for objects of type *synsem*. Figure 5 shows the relevant part of the lexical entry of the verb *lieben* (love) which allows projection from the object but not the subject:

$$\left[\begin{array}{l} \text{PHON|PHON-STR } \langle \textit{lieben} \rangle \\ \text{ARG-S } \left\langle \begin{array}{l} \text{LOC|CAT|HEAD } \left[\begin{array}{l} \textit{noun} \\ \text{CASE } \textit{nom} \end{array} \right] \\ \text{FPP } \textit{minus} \end{array} \right\rangle, \begin{array}{l} \text{LOC|CAT|HEAD } \left[\begin{array}{l} \textit{noun} \\ \text{CASE } \textit{acc} \end{array} \right] \\ \text{FPP } \textit{plus} \end{array} \right\rangle \end{array} \right]$$

Figure 5: The focus projection potential of *lieben*

The extended focus projection principle is shown in figure 6. The new, third

$$\begin{array}{l} \textit{phrase} \rightarrow \left[\begin{array}{l} \text{INFO-STR|FOCUS } \boxed{1} \oplus \textit{collect-focus}(\boxed{2}) \\ \text{HEAD-DTR|INFO-STR|FOCUS } \boxed{1} \\ \text{NON-HEAD-DTRS } \boxed{2} \end{array} \right] \\ \\ \vee \left[\begin{array}{l} \text{PHON|PHON-STR } \boxed{1} \oplus \boxed{2} \\ \text{SS|LOC } \left[\begin{array}{l} \text{CAT|HEAD } \textit{noun} \vee \textit{prep} \\ \text{CONT|LF } \boxed{3} \end{array} \right] \\ \text{INFO-STR|FOCUS } \langle \boxed{3} \rangle \\ \textit{any-dtr} \left(\left[\begin{array}{l} \text{PHON|PHON-STR } \boxed{2} \\ \text{SS|L|CONT|LF } \boxed{4} \\ \text{INFO-STR|FOCUS } \langle \boxed{4} \rangle \end{array} \right] \right) \end{array} \right] \\ \\ \vee \left[\begin{array}{l} \text{SYNSEM|LOC } \left[\begin{array}{l} \text{CAT|HEAD } \textit{verb} \\ \text{CONT|LF } \boxed{3} \end{array} \right] \\ \text{INFO-STR|FOCUS } \langle \boxed{3} \rangle \\ \text{NON-HEAD-DTRS } \langle \dots, \left[\begin{array}{l} \text{SYNSEM } \left[\begin{array}{l} \text{FPP } \textit{plus} \\ \text{LOC|CONT|LF } \boxed{4} \end{array} \right] \\ \text{INFO-STR|FOCUS } \langle \boxed{4} \rangle \end{array} \right], \dots \rangle \end{array} \right] \\ \\ \vee \dots \end{array}$$

Figure 6: Extended focus projection principle

⁹The value of FOCUS is a list to account for multiple foci, cf. De Kuthy (2002, p. 164).

disjunct specifies under which circumstances focus can project in the verbal domain: a phrase headed by a verb can only be in the focus (i.e., its entire logical form is token identical to an element of its focus value) if the daughter that has the focus projection potential (FPP *plus*) is entirely focused itself.

Finally, in order to account for the particular construction under discussion in this paper, the partial fronting of a non-finite constituent, the specific information structure properties of such fronted constituents need to be expressed in a principle expressing what we referred to as Webelhuth's generalization: In an utterance in which a verb phrase occurs as a fronted constituent (i.e., the filler of a head-filler phrase) this entire verb phrase must be in the focus of the utterance (i.e., the FOCUS value of the fronted constituent must be identical to its semantic representation). Figure 7 shows the formalization of this principle.

$$\left[\begin{array}{l} \textit{head-filler-phrase} \\ \text{NON-HEAD-DTR|SYNSEM|LOC|CAT|HEAD } \textit{verb} \end{array} \right] \rightarrow \left[\begin{array}{l} \text{INFO-STRUC|FOCUS } \langle \boxed{\text{I}} \rangle \\ \text{NON-HEAD-DTR } \left[\begin{array}{l} \text{INFO-STRUC|FOCUS } \langle \boxed{\text{I}} \rangle \\ \text{SYNSEM|LOC|CONT|LF } \boxed{\text{I}} \end{array} \right] \end{array} \right]$$

Figure 7: Webelhuth's generalization

Combining the new lexical specifications, the focus projection rule for the verbal domain, and the partial fronting focus requirement with the basic setup of De Kuthy (2002) one obtains a theory which predicts that subjects can only be part of a fronted verbal projection if they can be the focus exponent.

3.1 An example analysis

Now that we have introduced the basic principles governing the interaction of intonational marking, syntactic structure, and information structure, let us take a look at how an example in which a subject has been fronted as part of a fronted verbal projection is licensed by our theory. Example (19) is an instance of such a construction; the analysis of this example is shown in figure 8.

- (19) \llbracket [Ein AUSSENSEITER gewonnen] \rrbracket_F hat hier noch nie.
 an outsider won has here still never
 'An outsider has never won here yet.'

4 Summary and Outlook

In this paper we have investigated the fronting of subjects as part of a non-finite constituent in German, in particular the so-called definiteness effect excluding (many) definite subjects from this position. Based on generally ignored counterexamples to this definiteness effect, we explored the connection between focus projection and the partial fronting cases. We showed that it is the subject of those verbs which allow their subject to be the focus exponent that can be included as part of a fronted verbal constituent. In combination with the observation by Webelhuth (1990) that fronted constituents containing a verb need to be focused, this provides a natural explanation of the definiteness effect in terms of the information structure requirements in these sentences. The apparent exceptions to the definiteness effect were shown to involve definite noun phrases which can bear focus, which allows them to be part of a fronted verbal constituent. Finally, building on the information structure setup provided in De Kuthy (2002), we presented an HPSG theory which encodes the proposed analysis.

Given the complexity of focus projection in the verbal domain, there are a number of relevant issues that remain to be addressed in future work. Apart from integrating additional factors influencing focus projection, such as word order effects, Webelhuth's claim that a fronted constituent containing a verb has to be focused requires discussion on a wider empirical basis. Example (20) shows that the so-called *i*-topicalization (cf., Höhle 1991, Krifka 1994, Jacobs 1997 and Büring 1999) is a possible focus-background structure for sentences with a fronted verbal constituent.

(20) Hat hier je ein Außenseiter gewonnen? / Did an outsider ever win here?

- a. Nein, \llbracket [ein /AUSSENSEITER gewonnen] \rrbracket_T hat hier noch NIE\, aber es
no an outsider won has here still never but it
haben schon viele Erstplazierte verloren.
have yet many first placed lost
- b. Nein, [ein Außenseiter \llbracket /GEWONNEN \rrbracket_T] hat hier noch NIE\, aber es
no an outsider won has here still never but it
sind schon viele auf dem zweiten Platz gelandet.
are already many on the second place arrived

In light of such examples, Webelhuth's generalization that the only possible focus-background structure for sentences with a fronted verbal constituent has the entire fronted constituent in focus is too restrictive. One possibility we are investigating is whether instead of requiring the fronted constituent to be focused one can require it to be a uniform information unit.

Another aspect of Webelhuth's generalization to be investigated concerns its deeper motivation. Research into the focus-background structure of partial constituents in general is needed to be able to deduce rather than stipulate the information structure requirements of fronted partial constituents.

Based on the approach developed in this paper, we think these issues can be fruitfully explored.

Acknowledgements We would like to thank Doug Arnold, Tilman Höhle, Florian Jaeger, Stefan Müller, Gert Webelhuth, and the audience at the HPSG conference in East Lansing and the HPSG Germanic Workshop in Bremen for their helpful feedback.

References

- Büring, Daniel (1999). Topic. In Peter Bosch and Rob van der Sandt (eds.), *Focus*, Cambridge, UK: Cambridge University Press, Studies in Natural Language Processing, pp. 142–165.
- De Kuthy, Kordula (2002). *Discontinuous NPs in German — A Case Study of the Interaction of Syntax, Semantics and Pragmatics*. Stanford, CA: CSLI Publications.
- Engdahl, Elisabet and Enric Vallduví (1996). Information Packaging in HPSG. In Claire Grover and Enric Vallduví (eds.), *Studies in HPSG*, Edinburgh: The University of Edinburgh, vol. 12 of *Edinburgh Working Papers in Cognitive Science*, pp. 1–31.
- Féry, Caroline (1993). *German Intonational Patterns*. No. 285 in *Linguistische Arbeiten*. Tübingen: Max Niemeyer Verlag.
- Grewendorf, Günther (1989). *Ergativity in German*. No. 35 in *Studies in Generative Grammar*. Dordrecht: Foris Publications.
- Grewendorf, Günther and Wolfgang Sternefeld (eds.) (1990). *Scrambling and Barriers*. Amsterdam: John Benjamins Publishing Co.
- Haider, Hubert (1982). Abhängigkeiten und Konfigurationen: Zur deutschen V-Projektion. *Groninger Arbeiten zur germanistischen Linguistik (GAGL)* 21, 1–59.
- Haider, Hubert (1990). Topicalization and Other Puzzles of German Syntax. In Grewendorf and Sternefeld (1990), pp. 93–112.
- Höhle, Tilman N. (1991). On Reconstruction and Coordination. In Klaus Netter Hubert Haider (ed.), *Representation and Derivation in the Theory of Grammar*, Dordrecht: Kluwer Academic Publishers, vol. 3, pp. 139–197.
- Höhle, Tilman N. (1997). Vorangestellte Verben und Komplementierer sind eine natürliche Klasse. In Christa Dürscheid, Karl Heinz Ramers and Monika Schwarz (eds.), *Sprache im Fokus. Festschrift für Heinz Vater zum 65. Geburtstag*, Tübingen: Max Niemeyer Verlag, pp. 107–120.
- Jacobs, Joachim (1983). *Fokus und Skalen. Zur Syntax und Semantik der Gradpartikel im Deutschen*. Tübingen: Max Niemeyer Verlag.
- Jacobs, Joachim (1997). I-Topikalisierung. *Linguistische Berichte* 168, 91–133.
- Kratzer, Angelika (1984). On Deriving Syntactic Differences between German and English. Ms. (incomplete), TU Berlin, Institut für Linguistik, 47 pp.

- Krifka, Manfred (1992). A Compositional Semantics for Multiple Focus Constructions. In Joachim Jacobs (ed.), *Informationsstruktur und Grammatik*, Opladen: Westdeutscher Verlag, pp. 17–54.
- Krifka, Manfred (1994). Focus and Operator Scope in German. In Peter Bosch and Rob van der Sandt (eds.), *Focus and Natural Language Processing*, Heidelberg: IBM, vol. 1(6) of *Working Papers of the IBM Institute for Logic and Linguistics*.
- Löbner, Sebastian (1985). Definites. *Journal of Semantics* 4, 279–326.
- Meurers, Walt Detmar (2000). *Lexical Generalizations in the Syntax of German Non-Finite Constructions*. No. 145 in Arbeitspapiere des SFB 340. Tübingen: Universität Tübingen. (= Ph. D. thesis, Universität Tübingen, 1999). <http://ling.osu.edu/~dm/papers/diss.html>.
- Müller, Stefan (2002). *Complex Predicates: Verbal Complexes, Resultative Constructions, and Particle Verbs in German*. No. 13 in *Studies in Constraint-Based Lexicalism*. Stanford, CA: CSLI Publications. <http://www.dfki.de/~stefan/Pub/complex.html>.
- Pollard, Carl and Ivan A. Sag (1994). *Head-Driven Phrase Structure Grammar*. Chicago, IL: University of Chicago Press.
- Sailer, Manfred (2000). Combinatorial Semantics and Idiomatic Expressions in Head-Driven Phrase Structure Grammar. Ph.D. thesis, Universität Tübingen. <http://www.sfs.uni-tuebingen.de/~mf/neudiss/>.
- Stechow, Arnim von (1981). Presupposition and Context. In U. Mönnich (ed.), *Aspects of Philosophical Logic*, Dordrecht: Reidel, vol. 147 of *Synthese Library*, pp. 157–225.
- Stechow, Arnim von and Susanne Uhmman (1986). Some Remarks on Focus Projection. In Werner Abraham and Sjaak de Meij (eds.), *Topic, Focus, and Configurationality*, Amsterdam: John Benjamins Publishing Co., pp. 295–320.
- Toman, Jindrich (1986). A (Word-) Syntax for Participles. *Linguistische Berichte* 105, 367–408.
- Uhmman, Susanne (1991). *Fokusphonologie - Eine Analyse deutscher Intonationsskonturen im Rahmen der nicht-linearen Phonologie*, vol. 252 of *Linguistische Arbeiten*. Tübingen: Max Niemeyer Verlag.
- Webelhuth, Gert (1990). Diagnostics for Structure. In Grewendorf and Sternefeld (1990), pp. 41–75.
- Wegener, Heide (1990). Der Dativ—ein struktureller Kasus? In Gisbert Fanselow and Sascha W. Felix (eds.), *Strukturen und Merkmale syntaktischer Kategorien*, Tübingen: Gunter Narr Verlag, vol. 39 of *Studien zur deutschen Grammatik*, pp. 70–103.
- Wurmbrand, Susi (2001). AGREE—The other VP-internal subject hypothesis. In Karine Megerdooomian and Leora Anne Bar-el (eds.), *WCCFL 20: Proceedings of the 20th West Coast Conference on Formal Linguistics*. Somerville, MA: Cascadilla Press, pp. 635–648.

A two-rule analysis of measure noun phrases

Dan Flickinger 

Stanford University

Francis Bond 

NTT Communication Science Labs

Proceedings of the 10th International Conference on
Head-Driven Phrase Structure Grammar

Michigan State University

Stefan Müller (Editor)

2003

Stanford, CA: CSLI Publications

pages 111–121

Flickinger, Dan & Francis Bond. 2003. A two-rule analysis of measure noun phrases. In Stefan Müller (ed.), *Proceedings of the 10th International Conference on Head-Driven Phrase Structure Grammar, Michigan State University*, 111–121. Stanford, CA: CSLI Publications. DOI: 10.21248/hpsg.2003.7. 

Abstract

In this paper we present an analysis of English measure noun phrases. Measure noun phrases exhibit both distributional idiosyncrasy, in that they appear in positions normally filled by degree adverbs: *a ten inch long string*; and agreement discord: *ten inches is enough, it is ten inch/*inches long*. The analysis introduces one idiosyncratic construction, the Measure Phrase Rule, which links together syntax and inflectional morphology. Combined with existing rules, in particular the Noun-noun Compound Rule, the new rule accounts for the both the distributional and agreement idiosyncrasies. The rule has been implemented and tested in the ERG, a broad-coverage grammar of English. Our analysis supports the position that broad-coverage grammars will necessarily contain both highly schematic and highly idiosyncratic rules.

1 Introduction

One of the central themes within the HPSG framework involves the use of a small number of rule schemata to express generalizations about a wide range of syntactic and semantic phenomena. Pollard and Sag (1994) present a handful of rules and show how they can be employed in combination with a rich lexicon to provide explanatory analyses of much of English syntax. Even seemingly idiosyncratic phenomena like English number expressions (Smith, 1999) and tag questions (Bender and Flickinger, 1999) have been analyzed without requiring the addition of special-purpose rule schemata to the grammar. There are, however, phenomena which do seem to require construction-specific syntactic rules (Sag, 1997), either because the construction itself contributes semantic content, as with noun-noun compounds, or because a phrase is exocentric, exhibiting a syntactic distribution not predictable from its head daughter, as with gerunds (Malouf, 2000) (e.g. *Not hiring Sandy will make Kim unhappy*). In this paper we present an analysis of another phenomenon in English which requires this kind of special-purpose syntactic machinery, namely measure noun phrases like the ones illustrated in (1):

- (1) a. *I need a cord that is ten feet long.*
- b. *I need a ten foot long cord.*
- c. *This bookcase is two shelves higher than my old one.*
- d. *That three gallons was enough to get me home.*
- e. *Kim gave me twelve dollars, but I have already spent it/#them.*

The phrases *ten feet* and *two shelves* have the distribution here of degree specifiers like *very* or *much*, yet consist of a numerical expression and a noun, neither of which lexically possess the properties needed to license their appearance as a degree specifier. Further, the noun inflects differently in predicative adjective phrases (1a) and attributive adjective phrases (1b).

Another well known property of measure noun phrases is that, even though their head is plural, they can be modified by singular determiners, and agree with

singular verbs, as in (1d) (e.g., Payne and Huddleston, 2002, 354). In addition, a measure noun phrase can be referred to by a singular pronoun, as in (1e). Bond (2001) points out that such noun phrases are ambiguous. If the noun phrase refers to 12 actual dollar coins or notes, then the noun phrase is a prototypical noun phrase, and is referred to using a plural pronoun. However, if the noun phrase is a measure noun phrase then it refers to an amount of 12 dollars; this could be made up of 12 dollar coins, 6 two dollar coins, a 10 dollar note and some change or even a check. In this case the amount must be referred to using a singular pronoun *it*.

These surprising properties support the need for a syntactic structure that is specific to this phenomenon. Ross (1995) showed that measure noun phrases are one of several classes of nouns that do not show the full range of behaviors that prototypical noun phrases do: they are defective noun phrases. In particular they do not exhibit all of the following behaviors: definite pronominalization; modifiability by a full range of determiners and modifiers; pluralizability and the triggering of number agreement; and the ability to undergo movement (such as passive, topicalization and various dislocations).

2 Analysis

We cannot introduce a syntactic rule that simply combines a number expression like *ten* or *two hundred fifty* with a count noun that agrees in number, where the rule's mother supplies the syntactic and semantic properties of a degree specifier. This would not allow for the number agreement mismatches: "*This ten feet is more frayed than the first piece of rope.*". Instead we need an exocentric rule that produces the singular N-bar *ten feet*, where the plurality of the right daughter noun is not preserved on the mother. We elaborate this rule slightly so the resulting measure phrase also has the necessary property to serve as a degree specifier: its distinguished semantic relation is a *degree_rel*.¹ The rule (2) builds a non-headed nominal phrase with two daughters, the left a numerical expression² and the right a noun.

¹We adopt Minimal Recursion Semantics ((Copestake et al., 1999)) as the semantic framework for this analysis, but focus in this paper on the syntactic properties of measure phrases.

²We use the type *card-adj* (cardinal adjective) which includes numbers and other quantifiers such as *several*.

(2) Measure-Phrase Rule

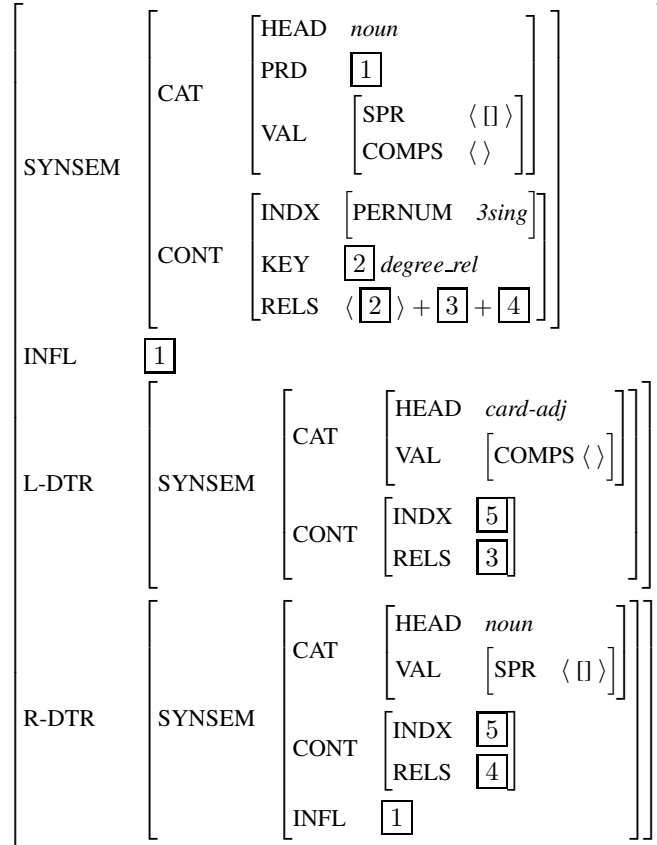

This Measure Phrase (MP) rule admits the underlined phrases in (1) above, as well as in the following examples:

- (3) a. *The building was several stories tall.*
 b. *The first asteroid landed ten yards in front of me.*
 c. *The next winning game would be just one city later.*

We note in passing that this binary-branching MP rule does not predict the grammaticality variation in examples where the measure noun appears alone, as in (4), but will focus in this paper only on an analysis of the binary structures.

- (4) a. *The next village was miles away.*
 b. **The village was mile away.*
 c. *He collapsed inches from the finish line.*
 d. ?*He collapsed feet from the finish line.*
 e. **I need a cord that is feet long.*
 f. **Gallons is required to get me home.*

This MP rule must also account for the striking difference in inflection for measure phrases appearing in attributive vs. predicative adjective phrases, as illustrated in (5):

- (5) a. *I bought a fourteen inch high candlestick.*
b. **I bought a fourteen inches high candlestick.*
c. *I bought a candlestick that is fourteen inches high.*
d. **I bought a candlestick that is fourteen inch high.*

While it might seem that the correlation between the attributive/predicative property and the form of the noun in the measure phrase involves singular vs. plural inflection on the noun, this would require a more complex interaction between the numerical adjective and the noun it modifies, even though this agreement follows just the expected pattern for the numeral *one* as seen in the contrast in (6).

- (6) a. *I bought a candlestick that is one inch high.*
b. **I bought a candlestick that is one inches high.*

If the *inch* in *fourteen inch high candlestick* is marked for singular number agreement, then the MP rule would have to require all numerals to appear with a singular noun if the measure phrase is in an attributive context, but to preserve the usual number agreement alternation when used in predicative phrases. Expressing such a feature co-occurrence restriction would require a complex distributed disjunction of values for the two features encoding number and predicativity, and would in our view lack explanatory force.

Instead, we argue that the nouns in measure phrases specifying attributive adjectives are in fact the stem forms, which are not yet inflected and hence underspecified for number. While most syntactic rules require that the daughter signs be fully inflected words or phrases, we propose that the MP rule is unusual in permitting an uninflected lexeme to enter the phrase structure without first undergoing inflectional morphology. Kiparsky (1982) suggests a similar approach where the left hand member in noun-noun compounds is uninflected. In particular, we assume that lexical signs bear the boolean (non-head) feature INFL, and that most entries in the lexicon are stem forms, marked [INFL –], with the inflectional rules producing from these stems syntactically admissible words which are [INFL +]. The MP rule simply requires that its nominal daughter identify its value for INFL with the mother's value for the boolean feature PRD used to distinguish attributive and predicative phrases, where this PRD feature is further identified for the two daughters in the general Specifier-Head rule which we use to combine *two foot* with *long* in *two foot long*. The left and right daughters do agree in number (INDX is co-indexed between them). However it is not co-indexed with the head (the head is always [INDX [PERNUM 3rdsing]]).

This analysis of the contrasts in (5) above in terms of inflection makes an interesting prediction about measure phrases containing nouns which ordinarily only

appear with plural inflection, such as *scissors*. Consider the examples in (7), which exhibit nearly the predicted judgments, where (7a) would be surprising if the nominal daughter in attributively used measure phrases had been constrained to be singular as in the candidate analysis we rejected:

- (7) *Though most sewing cabinets have a small drawer large enough for only one pair of scissors,*
- a. *my sister's cabinet has a three scissor wide drawer.*
 - b. *? my sister's cabinet has a three scissors wide drawer.*
 - c. *my sister's cabinet drawer is three scissors wide.*
 - d. ** my sister's cabinet drawer is three scissor wide.*

Example (7b) appears to be acceptable to some speakers. This judgment can be accommodated in our proposed analysis by adding the form *scissors* to the lexicon as already marked for plural number but still keeping the strong assumption that all lexemes are constrained to be [INFL –] (analogous to Kiparsky's *mice*). Indeed, this measure phrase construction might serve as a useful source of illumination on the question of how lexically plural nouns ought to be defined within the lexicon.

We have proposed an analysis of measure phrases used as degree specifiers for adjectives, but have not yet accounted for the use of measure phrases as direct modifiers of nouns, as illustrated in (8):

- (8) a. *I bought a fourteen inch candlestick.*
- b. ** I bought a fourteen inches candlestick.*
 - c. *She lives in a six story building.*
 - d. ** She lives in a six stories building.*

We propose an analysis of noun-noun compound structures which constrains the left, non-head daughter to be attributive (in our notation, [PRD –]), sketched in (9). This, combined with the MP rule predicts exactly the data in (8). The measure phrase *fourteen inch* is perfectly suited to be the non-head daughter, while the [PRD +] phrase *fourteen inches* is not. Since the noun-noun compound rule already provides an underspecified two-place predicate (*arg1-2_rel*) relating the semantics of its two daughters, this same relation can also accommodate the underspecification of the dimension for which the measure phrase expresses a degree. That is, *a two foot cable* can describe either the length or the width of the cable (at least), and all we know from the compound construction is that whatever the dimension is, its extent is limited to two feet.

(9) Noun-noun Compound Rule

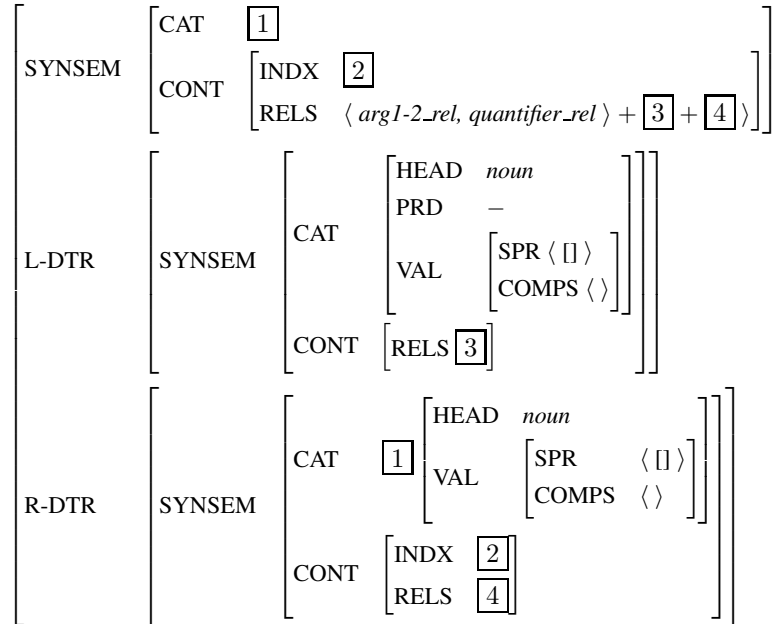

The noun-noun compound rule also provides a *quantifier_rel* to bind the instance variable of the non-head daughter.

Finally we account for the absence of attributive measure phrases as independent noun phrases, as shown in (10):

- (10) a. Fourteen inches is high enough.
 b. *Fourteen inch is high enough.

This contrast is obtained by constraining the MP rule so that the INFL value of the mother is the same as that of its nominal daughter. Therefore attributive (and hence non-inflected) measure phrases cannot be independent phrasal arguments, given our earlier assumption that most syntactic rules require fully inflected daughters.

Measure phrases (such as *twelve dollars* in *It costs twelve dollars*), in combination with their governing verb, predicate an amount; they do not refer to an entity or entities. Note, however, that a sentence like *I saw twelve dollars lying on the ground* has two interpretations. In one, the noun phrase is referential and there are twelve dollar notes or coins lying on the ground. In the other it is a measure phrase, in which case there could be 24 fifty cent coins, 12 dollar coins, 6 two dollar coins or any combination that adds up to a value of twelve dollars.

3 Implementation

A version of this analysis has been successfully implemented in a wide coverage grammar of English (ERG (Flickinger, 2000)) and tested extensively on data from

several domains, including meeting scheduling and travel planning (Verbmobil), and electronic commerce. For access to the implementation and the data, visit <http://lingo.stanford.edu>.

In the actual implementation, there are two measure-phrase rules which inherit from a common supertype `basic_measure_np_phrase`: the binary rule `binary_measure_np_phrase` which is presented above in (2), and a unary rule `bare_measure_np_phrase`.³ The unary rule produces measure noun phrases with no explicit numerical phrase, as in (4) above and perhaps also in (11).

(11) *I read that years ago*

4 Distribution

We examined the distribution of the measure NP rule in a treebank (Oepen et al., 2002) of VerbMobil data (CD 6) (Wahlster, 2000). In 3,000 analyzed sentences there were 23 uses of the measure phrase rule in the top ranked parse (0.8%). A typical usage is given in (12).

(12) I attended *a two hour (long) meeting*.

The rule was also applied in at least one parse that was dis-preferred for 120 other utterances, such as (13).

(13) # *I attended a meeting later*.

5 Conclusions

We draw two conclusions from this analysis of measure phrases. First, we found evidence through this analysis that the constituents which appear in phrase structure are not always fully inflected, blurring the boundary between syntax and inflectional morphology. Second, it is clear that the surprising distributional characteristics of these phrases would be difficult to account for without positing an idiosyncratic syntactic rule of the kind we propose, lending support to the position that broad-coverage grammars will necessarily contain both highly schematic and highly idiosyncratic rules.

6 Further Work

We would like to extend this work in three ways. The first is to investigate the behavior of measure noun phrases in other languages. Preliminary investigations

³In written English, the noun can precede the number if it is a currency unit: *two hundred dollars* vs *\$ 200*. This could be dealt with in two ways, either by using a preprocessor to rewrite the symbol into a word following the number, or to have two binary rules - the one presented in (2) and a second one, where the left and right daughters are reversed and the noun (right daughter) is constrained to be `common_noun_numcomp_synsem`, used for currency signs such as \$, £ and AUD.

into German show very different behavior: there is no link between inflection and predicativeness. Instead, there appears to be a sharp distinction between units and other nouns. Units (*meter, ...*) have no morphological singular/plural distinction (like English *sheep*) (14).⁴ Other common nouns inflect for plural both in both predicative and attributive position (15). Semantically motivated discord is also present in German, although either singular or plural agreement is acceptable.

- (14) a. *ein Fünfhundert-Euro-Artikel*
 a five-hundred-Euro-article
 A five hundred Euro article
- b. *ein fünfhundert Euro teurer Artikel*
 a five hundred Euro expensive article
 An article costing five hundred Euros
- c. *der Artikel kostet fünfhundert Euro*
 the article costs five hundred Euro
 An article costing five hundred Euros
- d. *Fünfhundert Euro ist genug*
 five hundred Euro is enough
 Five hundred Euros is enough
- e. *Fünfhundert Euro sind genug*
 five hundred Euro are enough
 Five hundred Euros are enough
- f. *Fünfhundert Euros ist genug* (Euro coins)
 five hundred Euros is enough
 Five hundred Euros is enough
- g. *Fünfhundert Euros sind genug* (Euro coins)
 five hundred Euros are enough
 Five hundred Euros are enough
- (15) a. *ein Fünf-Seiten-Artikel*
 a five-pages-article
 A five hundred page article
- b. *ein fünf Seiten länger Artikel*
 a five pages long article
 A five hundred page long article
- c. *der Artikel ist fünf Seiten lang*
 the article is five pages long
 The article is five pages long

⁴The German word *Euro* has a plural, but it is only used when referring to the coins, not the currency.

The second extension is to investigate the history of this construction in English. It was suggested to us by Bill Ladusaw (p.c.) that it may be linked to the loss of case inflections over time.

Finally, we would like to examine the overall distribution of signs in corpora. The aim is to answer two questions: (1) How many rule-schema do we need? (2) How are they distributed? We hypothesize that the distribution follows a power law: a few constructions are used very frequently, and a great many are used infrequently. That is, we expect the distribution to be similar to that of words. Further, we expect an inverse correlation between how constrained a rule is and how frequent it is, although it is not yet clear how to quantify this. We will use the Redwoods Treebank data (<http://lingo.stanford.edu/redwoods/>) for the ERG as the basis for this line of investigation.

Acknowledgments

We would like to thank the members of the Lingo project, the audience at HPSG-2003, and Birte Lönneker for their helpful comments and discussion. This material is based upon work supported by the Research Collaboration between NTT Communication Science Laboratories, Nippon Telegraph and Telephone Corporation and CSLI, Stanford University.

References

- Emily Bender and Dan Flickinger. Peripheral constructions and core phenomena. In Weibelhuth et al. (1999), pages 199–214.
- Francis Bond. *Determiners and Number in English contrasted with Japanese — as exemplified in Machine Translation*. PhD thesis, University of Queensland, Brisbane, Australia, 2001.
- Ann Copestake, Dan Flickinger, Carl Pollard, and Ivan A. Sag. Minimal recursion semantics: An introduction. (manuscript <http://www-csli.stanford.edu/~aac/papers/newmrs.ps>), 1999.
- Dan Flickinger. On building a more efficient grammar by exploiting types. *Natural Language Engineering*, 6(1):15–28, 2000. (Special Issue on Efficient Processing with HPSG).
- Rodney D. Huddleston and Geoffrey K. Pullum. *The Cambridge Grammar of English*. Cambridge University Press, Cambridge, 2002. (principal authors).
- Paul Kiparsky. Lexical phonology and morphology. In In-Seok Yang, editor, *Linguistics in the Morning Calm*, pages 3–91. Hansin, 1982.
- Robert Malouf. *Mixed Categories in the Hierarchical Lexicon*. CSLI Publications, 2000.

- Stephan Oepen, Dan Flickinger, Kristina Toutanova, and Christopher D. Manning. LinGO redwoods: A rich and dynamic treebank for HPSG. In *Proceedings of The First Workshop on Treebanks and Linguistic Theories (TLT2002)*, Sozopol, Bulgaria, 2002.
- John P. Payne and Rodney D. Huddleston. Nouns and noun phrases. In *The Cambridge Grammar of English* Huddleston and Pullum (2002). (principal authors).
- Carl Pollard and Ivan A. Sag. *Head Driven Phrase Structure Grammar*. University of Chicago Press, Chicago, 1994.
- John Robert Ross. Defective noun phrases. In *Papers from the Regional Meeting of the Chicago Linguistic Society*, volume 31, pages 398–440. University of Chicago, 1995.
- Ivan A. Sag. English relative clause constructions. *Journal of Linguistics*, 33(2): 431–484, 1997.
- Jeffery D. Smith. English number names in HPSG. In Weibelhuth et al. (1999), pages 145–160.
- Wolfgang Wahlster, editor. *Verbmobil: Foundations of Speech-to-Speech Translation*. Springer, Berlin, Germany, 2000.
- Gert Weibelhuth, Jean-Pierre Koenig, and Andreas Kathol, editors. *Lexical and Constructional Aspects of Linguistic Explanation*. CSLI, Stanford, 1999.

Information structure and referential givenness/newness: How much belongs in the grammar?

Jeanette Gundel

University of Minnesota

Proceedings of the 10th International Conference on
Head-Driven Phrase Structure Grammar

Michigan State University

Stefan Müller (Editor)

2003

Stanford, CA: CSLI Publications

pages 122–142

Gundel, Jeanette. 2003. Information structure and referential givenness/newness: How much belongs in the grammar? In Stefan Müller (ed.), *Proceedings of the 10th International Conference on Head-Driven Phrase Structure Grammar, Michigan State University*, 122–142. Stanford, CA: CSLI Publications. DOI: 10.21248/hpsg.2003.8.



Abstract

This paper is concerned with such concepts as `topic`, `focus` and `cognitive status of discourse referents`, which have been included under the label `information structure`, as they relate in some sense to the distribution of given and new information. It addresses the question of which information structural properties are best accounted for by grammatical constraints and which can be attributed to non-linguistic constraints on the way information is processed and communicated. Two logically independent senses of given-new information are distinguished, one referential and the other relational. I argue that some phenomena pertaining to each of these senses must be accounted for in the grammar, while others are pragmatic effects that do not have to be represented in the grammar, since they result from interaction of the language system with general pragmatic principles that constrain inferential processes involved in language production and understanding.

1. Introduction

I will be concerned in this paper with such concepts as `topic`, `focus` and `cognitive status of discourse referents`, which have been included under the label `information structure` (alternatively `information status`), as they relate in some sense to the distribution of given and new information. As an invited speaker at this conference, I was asked to address the question: What do we know about information structure that would bear on what a grammatical theory like HPSG needs to take into account? With this in mind, I will focus on the question of which aspects of information structural concepts and their properties are grammatically constrained and which are constrained by general cognitive and communicative principles that are independent of grammar. These are broad questions, and I obviously cannot hope to answer them fully and completely here. Instead, I will outline the kind of framework that I think needs to serve as the background for asking these questions and will make some tentative proposals for selected informational structural facts and properties within that framework.

The approach to pragmatics I will assume here is that of Relevance Theory (henceforth RT). Within this framework, pragmatics is construed as an account of the inferential processes involved in understanding utterances, processes which take as their input the result of linguistic decoding and `enrich` that input by way of pragmatic inferences for those aspects of a speaker's intended meaning that are left underspecified by linguistic form, e.g. reference and ambiguity resolution and conversational implicature. Language generation and interpretation is thus seen as

constrained by the interaction of two independent systems, one grammatical the other pragmatic, where constraints imposed by the latter follow from the Principle of Relevance (Sperber and Wilson 1986, 1996). The fundamental goal of relevance theoretic pragmatics is to explain how the hearer is able to access the appropriate cognitive context for interpreting an utterance, i.e. which of the grammatically constrained, but still grossly underdetermined set of assumptions available to her is the one she is intended to use in processing the utterance. The distinction within HPSG between CONTENT and CONTEXT (Pollard and Sag 1994), where the value of the latter is the locus of pragmatic information, might at first seem anomalous on such an approach since, within RT, all linguistic input is viewed as constraining the context in which an utterance will be relevant. But the anomaly is only apparent, as it results from equivocation in the use of the terms ‘context’ and ‘pragmatics’, specifically whether these are construed as fully cognitive or not. For the purpose of this paper, I will take the formal construct CONTEXT within HPSG in a narrow sense to include those aspects of linguistic form represented by attributes whose values make direct reference to the utterance act and its participants. I take no position here on the question of whether the CONTEXT-CONTENT distinction is still necessary or even feasible under the relevance theoretic view of pragmatics outlined above, but this should have no bearing on the arguments presented. The main question will be what needs to be represented in the grammar and what doesn’t, independent of where and how it is represented.

2. What is Information Structure? Referential vs. Relational Givenness.

‘Information structure’ is a cover label for a number of distinct, though partly overlapping, concepts that have often been conflated in the literature. While many researchers have recognized that there are distinct notions involved here (cf. Birner and Ward 1998, Chafe 1976, Gundel 1988, Halliday 1967, Lambrecht 1994, Prince 1992, *inter alia*), there is as yet no general agreement on what the linguistically relevant constructs are, how many of them there are, and how and if they are related (see Gundel 1999a and Gundel and Fretheim 2003.) The situation is confounded by the fact that the different concepts all relate in one way or another to the distinction between given and new information, but in different ways; and even those who recognize the distinction between different informational structural concepts, treat the given-new distinction (at least implicitly) as if it were a unitary phenomenon. As Birner and Ward note (1998, p. 9) this work shares “a general approach based on the degree to which information is assumed to be available to the hearer prior to its evocation.” Their own work, following Prince (1992), recognizes a three-way distinction between what is old/new to the hearer, what is old/new to the discourse, and an

‘open proposition that is shared knowledge’ and ‘represents what is assumed by the speaker to be salient (or inferable) in the discourse’ (p. 12). But these three senses of givenness-newness are not logically independent. An ‘open proposition that is shared knowledge’ as well as anything that is Discourse Old is, by definition, also Hearer Old; these concepts differ only in the source of the givenness/newness (the discourse or general knowledge) and the nature of the object that has the givenness/newness property (a discourse entity or an open proposition). Since it is the link to given and new information that has been assumed to tie the various information structural concepts to ‘contextual/pragmatic’ information, a clear distinction between different senses of givenness/newness is crucial for understanding how and if various information structural properties are constrained by the grammar.

In my own work (e.g. Gundel 1988, 1999) I have argued that there are two distinct and logically independent senses of givenness-newness, one referential and the other relational. Referential givenness describes a relation between a linguistic expression and a corresponding non-linguistic (conceptual) entity in (a model of) the speaker/hearer’s mind, the discourse, or some real or possible world, depending on where the referents or corresponding meanings of these linguistic expressions are assumed to reside. The relevant parameters are whether or not it already exists in the model, its degree of salience and, for some authors (e.g. the distinction made by Prince 1992 and Birner and Ward 1998), how it got there and what kind of entity it is. Some representative examples include existential presupposition (e.g. Strawson 1964), various senses of referentiality and specificity (e.g. Fodor and Sag 1982, Enç 1991), the familiarity condition on definite descriptions (e.g. Heim 1982), the accessibility levels of Ariel (1988), the activation and identifiability statuses of Chafe (1994) and Lambrecht (1994), the familiarity scale of Prince (1981), and the cognitive statuses of Gundel, Hedberg and Zacharski (1993).

Relational givenness-newness, by contrast, involves a partition of the semantic/conceptual representation of a sentence into two complementary parts, X and Y, where X is what the sentence is about (the topic, theme, ground, logical/psychological subject) and Y is what is predicated about X (the comment, rheme, focus, logical/psychological predicate). X is given in relation to Y in the sense that it is independent, and outside the scope of, what is predicated in Y. Y is new in relation to X in the sense that it is information that is predicated (asserted, questioned, etc.) about X. Unlike referential givenness, this sense is a relation between two elements on the same level of representation, and can be defined independent of a speaker’s assumptions about the hearer’s knowledge or attention state. The relation may be construed as logico-semantic, a subject – predicate relation, or as conceptual/psychological/cognitive, the relation between an

entity represented in the hearer's memory (a file card to use a common metaphor) and what is added in relation to that entity. In either case, the distinction can be taken to reflect how the informational content of a particular event or state of affairs expressed by a sentence is represented and how its truth value is to be assessed. Examples of relational givenness-newness pairs include traditional notions of logical/psychological subject and predicate (e.g. van der Gabelenz 1868) presupposition-focus (e.g. Chomsky 1971, Jackendoff 1972, 2000), topic-comment (e.g. Gundel 1974/89, Reinhart 1981), theme-rheme (e.g. Mathesius 1928, Kuno 1972, Sgall et al 1973, 1986, Vallduví 1992), and topic-predicate (Erteschik-Shir 1997).

Referential and Relational Givenness-Newness are logically and empirically independent of one another. An entity can be referentially given, but part of what is relationally new, as in (1).

- (1) A. Who called?
 B. Pat said SHE called. (Gundel 1980)

If *SHE* refers to Pat, its referent is referentially given in virtually every possible sense. It is presupposed, specific, familiar, activated, in focus, hearer old, discourse old, and so on. But Pat is relationally new, (part of) the focus/comment/main predication, and so receives a focal accent here. Similarly, the referent of *HER* in (2), Mrs. Clinton, is referentially given, but relationally new, i.e. (part of) the focus of the sentence.

- 2) A. Good morning. I'm here to see Mrs. Clinton again.
 B: Sure. Mr. Smith. Let's see...One of her assistants will be with you in a second.
 C. I'd like to see [*HER*_F] today. I'm always talking to her assistants. (Vallduví and Engdahl 1996)

So-called `informative presupposition` clefts (Prince 1978) provide another example.

- (3)The federal government is dealing with AIDS as if the virus was a problem that didn't travel along interstate highways and was none of its business. It's this lethal national inertia in the face of the most devastating epidemic of the late 20th century that finally prompted one congressman to strike out on his own. [Ellen Goodman, op-ed column, 5/35/87, cited in Hedberg (1990)]

The underlined cleft clause in (3) is part of the relationally new information predicated about the topic of this sentence (the national inertia regarding AIDS), as indicated by the fact that it is the locus of focal stress

(on ‘own’). However, like all cleft clauses, it also has some degree of referential givenness. As Prince (1978) notes, it is treated by the speaker as if it were generally known, even though it may not be known to the hearer. Hedberg (2000) proposes an account that treats the content of the cleft clause as having some degree of referential givenness (albeit the lowest possible one) even for the hearer, since the hearer is expected to be able to construct a unique representation, the *x* that prompted one congressman to strike out on his own (against the AIDS epidemic), even if she has no previous knowledge that something fits this description. Hedberg argues that this property follows from the fact that the cleft pronoun and cleft clause form a discontinuous definite description and thus have the same referential givenness property as other definite descriptions, i.e. it must be uniquely identifiable (see below).

3. Grammatical Constraints or Pragmatic Constraints?

Having distinguished the two different senses of givenness-newness that pertain to various information structural concepts, we are now ready to ask the main question: how much belongs in the grammar? Due to space and time limitations. I will restrict the discussion here to referential givenness. See Gundel (forthcoming) for more complete discussion of both types of givenness-newness.

3.1 Referential Givenness-Newness. What’s in the grammar?

The referential givenness-newness concepts I will assume here are the cognitive statuses proposed in Gundel, Hedberg and Zacharski (1988, 1993). While these were originally proposed to account for the distribution and interpretation of referring expressions, they could in principle play a role in other aspects of language as well. It also remains to be demonstrated whether they are the only referential givenness notions that are linguistically relevant and whether related concepts, such as those noted in section 2, can be reduced to these. I think they can, but I will not be concerned with this question here.

Gundel, Hedberg and Zacharski start from the (uncontroversial) premise that the descriptive content of a nominal expression grossly underdetermines its interpretation. For example, the conceptual content encoded in the phrase *these primitive reptiles* in (4) constrains possible interpretations to primitive reptiles (assuming it is not used metaphorically),¹ but it provides no information about which primitive

¹ As Green (1997:9) notes, the condition on the descriptive content is pragmatic rather than semantic, namely “that the speaker believe that the addressee will recognize the speaker’s intention in USING the expression that its index be

reptiles are intended. In (5), the pronoun *they* provides even less descriptive information, as it only encodes the conceptual content that the intended referent is third person plural.

(4) A restudy of pareiasaurs reveals that these primitive reptiles are the nearest relatives of turtles. [M.S.Y. Lee, *The origin of the Turtle Body Plan*. Science, 1993, p. 1649].

(5'') A restudy of pareiasaurs reveals that **they** are the nearest relatives of turtles.

Yet English speakers have little trouble identifying the intended referents of both phrases as pareiasaurs, even if they don't know what pareiasaurs are.

The referent of (6), on the other hand, is not so easily resolved, and the most accessible interpretation here is one that is not coreferential with pareiasaurs (though it may be a set that includes pareiasaurs), despite the fact that the descriptive content is the same as for *these primitive reptiles* in (4).

(6) A restudy of **pareiasaurs** reveals that **the primitive reptiles** are the nearest relatives of turtles.

Gundel et al propose to account for such facts with a theory whose basic premise is that some determiners and pronouns constrain possible interpretations by conventionally signaling different cognitive statuses (memory and attention states) that the intended referent is assumed to have in the mind of the addressee. They propose six cognitive statuses, which are implicationally related in the Givenness Hierarchy in (7)

(7) The Givenness Hierarchy (GH) (Gundel, Hedberg and Zacharski 1993)

in				uniquely		type				
focus	>	activated	>	familiar	>	identifiable	>	referential	>	identifiable
<i>it</i>		<i>this/that/ this N</i>		<i>that N</i>		<i>the N</i>		<i>indefinite this N</i>		<i>a N</i>

anchored to" the intended referent. In most uses, this involves an assumption that the expression is normally used to refer to objects that have the properties encoded by the descriptive content of the phrase.

Statuses on the GH are conventional meanings of the form or forms listed under them.² Since each status entails all statuses to the right on the hierarchy (anything in focus is by definition also activated, anything activated is also familiar, and so on), a form that has a particular status as its conventional meaning is unspecified for higher statuses (statuses to the left) on the hierarchy, but does not exclude them. The forms thus restrict possible referents to those that are assumed to have (at least) the designated memory and attention status for the addressee. They can be thought of procedurally as processing instructions, as follows:

Type identifiable - identify what kind of thing this is.

Referential- associate a unique representation by the time the sentence is processed

Uniquely identifiable - associate a unique representation by the time the nominal is processed

Familiar - associate a representation already in memory

Activated - associate a representation from working memory

In focus - associate a representation that your attention is currently focused on.

Consider, for example, the sentences in (8a-f).

(8) I couldn't sleep last night.

a. A train kept me awake.

b. This train kept me awake

c. The train kept me awake.

d. That train kept me awake.

e. This train/this/that kept me awake.

f. It kept me awake.

The statuses range from least restrictive, 'type identifiable', to most restrictive, 'in focus'. In (8a) the addressee is only expected to identify what kind of thing a train is. In (8b) (on the 'indefinite *this*' interpretation), he is expected to associate a unique representation with the phrase *this train* by the time the sentence is processed. (8c) tells the addressee that he is expected to associate a unique representation by the time the noun phrase is processed. He can do this either by retrieving an existing representation from memory or by constructing a new unique representation. In (8d), he is told that he already has a representation of the train in memory; in (8e) he is instructed to associate a representation from

² Gundel, Hedberg and Zacharski investigated 5 languages in their 1993 work (English, Russian, Japanese, Mandarin, and Spanish.) The theory will be illustrated here using only English examples.

working memory; and in (8f) he is told to associate a representation that is currently in focus.

The theory makes a wide range of predictions, both categorical and probabilistic, about the distribution and interpretation of referring expressions. I discuss only a sample of these here. (See Gundel, Hedberg and Zacharski 1993, 2001 for more detailed discussion.) The interpretive facts in (4)-(6) above are explained as follows. The demonstrative determiner *this/these* explicitly signals that its referent is at least activated. Since there is only one plural entity in working memory at the particular point when the phrase *these primitive reptiles* is encountered, the referent is automatically resolved as pareiasaurs, even if the reader doesn't know what pareiasaurs are. The explanation in (5) is similar. The pronoun *they* requires its referent to be at least activated, and if unstressed (as is probably the case here) in the current focus of attention. Only one entity meets this condition here, pareiasaurs. So again the reference is automatically resolved, even without knowledge of what pareiasaurs are. The definite article in the phrase *the primitive reptiles* in (6), on the other hand, only requires the referent to be uniquely identifiable. The activated/in focus pareiasaurs meets this condition as it is already represented in working memory due to its mention in the previous sentence and anything activated is, by definition, also uniquely identifiable. But successful resolution here would depend on the interpreter's knowledge that pareiasaurs are primitive reptiles. Moreover, other primitive reptiles that might be represented in memory would meet the condition of being uniquely identifiable as well. And it would also be possible to construct a new unique representation of the whole class of primitive reptiles, if one doesn't already exist in memory. This is why the phrase in (6) has a different interpretation, and is also more difficult to resolve, than the corresponding phrases in (4) and (5).

Since cognitive statuses are properties of mental representations, not linguistic entities, it should be irrelevant how something acquires a particular status, e.g. whether by being linguistically introduced, by being present in the spatiotemporal context, or by being part of general background knowledge. The theory thus predicts correctly that linguistically introduced and non-linguistically introduced entities will be encoded in the same way. It also doesn't make a difference what type of thing is being referred to, e.g. whether it is a concrete object or an abstract entity such as a proposition or a fact, except in cases where the way such entities are introduced has bearing on cognitive status. This is illustrated in the following examples.

(9) Dentist to patient:

Did that hurt? [from Jackendoff 2002]

(10) “We believe her, the court does not, and that resolves the matter,”
[NY Times, 5/24/ 00]

(11) I tried the shirt on, but that was too big.

In (9) the pronoun *that* is used to refer to something the dentist just did, a representation of which can be assumed to be activated for the addressee, and thus meets the necessary condition for using this form. In (10), the same form is used to refer to a fact that can also be assumed to be activated, in this case because it has just been introduced linguistically by uttering the preceding clause. And in (11) *that* is being used to refer to an object, the shirt, that was activated by its mention in the preceding sentence.

(12) At one point, the hijacker fired a shot inside *the cockpit*, perhaps accidentally, one of the three pilots aboard said....[14 sentences later] Those aboard the plane did not get a good look at the hijacker because when he stood up, he told everyone to hide their faces in their laps and not look at him, then he walked to *the cockpit*, passengers said in radio reports.” [Associated Press, Hijacker Leaps to Safety after Robbing Passengers. 5.25.2000.]

(13) (Passenger on a plane) Do you know if the cockpit door is locked?

In (12), the definite article is used in referring to a cockpit that the hearer can be expected to uniquely identify, either by associating it with an existing representation in memory or by constructing a new representation that links it, by way of a bridging inference (Clark and Havilland 1977), to the recently mentioned plane.³ In (13), the phrase *the cockpit* is also used to refer to an entity that can be uniquely identified/represented by way of a bridging inference to an already activated entity, in this case the plane that the speaker and addressee are in.

(14) (Dentist to patient, who just winced) Did it hurt?

³ Note that the constraint on cognitive status itself cannot explain why the interpreter chooses the cockpit of the currently active plane over other cockpits that may be represented in memory and would thus be uniquely identifiable. An explanation of this requires an appeal to pragmatic (i.e. non-grammatical) constraints, specifically Relevance (see Gundel 1996 for further discussion of this point.)

(15) A. I finally had my wisdom tooth pulled.

B. Did it hurt?

In (14), the patient makes it clear that whatever the dentist just did is in his focus of attention, thus licensing the use of *it*. In (15), *it* is ambiguous between an interpretation where it refers to the process of A having his tooth pulled and one where it refers to the tooth itself. Each of these interpretations can be assumed to be in A's focus of attention because he just mentioned it.

Facts like those discussed above and many more like them can be accounted for straightforwardly in the grammar by constraining the relevant pronouns and determiners so that their CONTEXT attributes, and those of the phrases they are a part of, have the required cognitive status values associated with them.⁴ The constraints have access to pragmatic/contextual information only in the narrow sense that they make reference to the addressee's memory and attention state (more specifically to the speaker's mental model of that state). But in other respects, they are no different than other aspects of the conventional meaning of lexical items and thus clearly belong in the grammar. The cognitive status constraints could be viewed as an extension of the general framework for representing reference outlined in Green (1997), (or some version thereof) where contextual information is necessarily a part of the representation of all reference.

3.2. Referential givenness-newness. What's not in the grammar?

3.2.1. Salience-promoting factors

While statuses themselves are independent of how and if a particular entity was linguistically introduced, linguistic factors can influence the hearer's attention state with respect to some entity, specifically whether it is merely activated or brought into focus of attention. In English, this is most evident in the distribution of the personal pronoun *it* compared with the demonstrative pronouns *this* and *that*. As seen in (7), Gundel et al (1993) hypothesize that unstressed personal pronouns, including *it*, require their referents to be in focus. The demonstrative pronouns *this* and *that*, on the other hand, only require their

⁴ Since cognitive status is associated with the referent of the whole phrase and not just the determiner, I am assuming some mechanism for projecting the cognitive status value of individual lexical items to the noun phrase (or determiner phrase) as a whole.

referents to be activated, i.e. in working memory. Since anything in focus is by definition also activated, referents of demonstrative pronouns could be in focus, but they don't have to be, while the referent of *it* must be in focus, as illustrated in (16) and (17)

(16) The package was on the table. That looked new.

(17) The package was on the table. It looked new.

The demonstrative *that* in (16), could refer either to the package or to the table, as both meet the condition of being at least activated. In (17), on the other hand, an interpretation where *it* refers to the table is much less accessible, if it is possible at all. The package has been introduced in subject position, which always brings an entity into focus, while the table is less likely to be in focus since it has been introduced in a syntactically less prominent position.

The interpretive facts in (16) and (17) would follow straightforwardly from cognitive status constraints placed on the pronouns *it* and *that* in the grammar. The distinction in cognitive status encoded by these two different kinds of pronoun also provides a clue to the difference in their distribution in referring to entities such as propositions, facts, and situations, when these are evoked by non-nominal expressions. As seen in the examples in (9)-(11) and (14)-(15) above, both forms can be used to refer to such entities as well as to entities that represent concrete objects and ones that are not linguistically introduced at all. However, as shown by a number of studies, the personal pronoun *it* is much less frequently used than the demonstrative when the antecedent is not an NP (Webber 1988, 1991, Hegarty, Gundel and Borthen 2002, Byron and Allen 1998, inter alia). The use of one form rather than the other also sometimes results in a different interpretation. Compare (10) above (repeated here for convenience) with (18), for example.

(10) "We believe her, the court does not, and that resolves the matter,"
[NY Times, 5/24/ 00]

(18) We believe her, the court does not, and it resolves the matter,

Gundel et al (1993) attribute such facts to the independently motivated assumption that non-nominal constituents are less likely to bring an entity into focus of attention. The semantic type of the entity and other salience-promoting factors also play a role here (see Gundel, Hegarty and Borthen 2003). Thus, in (19), where the subject of the second sentence refers to the event directly introduced by the first sentence, reference with *it* is acceptable.

(19) Mary fell off her bike. It happened yesterday.

But since the act performed in uttering a sentence is activated, but never brought into focus (as focus of attention will be on some aspect of the content of the speech act, not the act itself) speech acts can only be referenced with a demonstrative, never with the pronoun *it*, as seen in (20) and (21).

(20) A. John snores.
B. That's rude.
B'. It's rude.

(21) A. I just ate three pieces of cake.
B. Can you repeat that.
B'. ? Can you repeat it.

In (21), *that* is ambiguous between an interpretation where it refers to John's snoring and one where it refers to the addressee's act of saying that John snores. But *it* can only refer to the snoring itself. Similarly, in (21), *that* can refer either to the act of eating three pieces of cake or to the addressee's act of saying that she just ate three pieces of cake. But *it* can only refer to the act of eating the cake.

The fact that entities introduced by non-nominal expressions are less likely to be accessible to reference with the personal pronoun *it* than with a demonstrative pronoun can thus be shown to follow from interaction of the grammatical constraint that *it*, unlike *this/that*, requires its referent to be in focus with the non-grammatical fact that certain contexts are more salience promoting than others. For example, introduction in syntactically prominent positions promotes the salience of a referent, whereas performing a speech act directs the addressee's focus of attention to certain aspects of the content of the act, not to the act itself. It may, however, also be possible to account for the facts in question, at least partially, by representing the structural and semantic properties that correlate with the distribution and interpretation of *it* vs. *this/that* directly in the grammar. For example, *it* might be constrained so that it can only refer to entities introduced in certain NP positions (e.g. subject), to clausal complements of factive verbs (see Hegarty et al 2002), to certain semantic types (e.g. objects and events) and so on. Depending on one's goals, such an account might even be preferable to the one proposed here, as it would directly align the facts about referring forms and linguistic contexts without appealing to cognitive status, and specifically to attention states such as 'activated' and 'in focus', which cannot easily be determined by the grammar. But it would fail to explain why the correlations between

referring forms and linguistic contexts are as they are and not otherwise, and would provide little insight into how such forms are processed and interpreted. It would also preclude a principled distinction between facts that are due to (knowledge of) the language system and more general factors governing information processing, such as the role played by linguistic and other factors in promoting the salience of representations. Moreover, there is no single structural context that can be directly correlated with the use of *it* vs. *this/that*, and the relevant factors are sometimes not linguistic at all (Gundel, Borthen, and Fretheim 1999, Hegarty, Gundel and Borthen 2002, Gundel, Hegarty and Borthen 2003). Unless the goals are purely practical ones, then, grammatical constraints on referring forms that make direct reference to cognitive status values would be preferable to ones that attempt to constrain referring forms in terms of the linguistic contexts that contribute to different statuses.

3.2.2. Conversational implicatures

As noted in section 2, the statuses are in a unidirectional entailment relation (anything in focus is, by definition, also activated; anything activated is also familiar, and so on). The informal notion of ‘definiteness’ thus simply falls out as an effect of the hierarchy, since forms that have been characterized as ‘definite’ are all constrained to refer to entities that are uniquely identifiable by the addressee, either directly, as in the case of the definite article, or by implication, as with forms that overtly signal statuses that entail ‘uniquely identifiable’ (demonstratives and personal pronouns like ‘it’, ‘she’, etc.). This much can be predicted by the grammar, assuming some statement about the unidirectional entailment relation that holds for statuses on the hierarchy, and there is no need for a separate ‘definiteness’ feature. The hierarchy also predicts correctly that there will be a one to many mapping between statuses and forms in language use, since forms are underspecified for higher statuses, rather than excluding them. Thus, for example, corpus studies have found that less than half of the phrases introduced by a definite article refer to entities that have been previously mentioned in the discourse and 30%-60% (depending partly on the genre examined) refer to entities that cannot be assumed to be familiar to the addressee in any sense, either from the discourse or from general experience (cf. Fraurud 1990, Gundel et al 1993, 2000, Poesio and Vieira 1998). This is perfectly consistent with the Givenness Hierarchy constraints imposed on the definite article by the grammar, since the definite article only restricts possible referents to ones that can be uniquely identified/represented, regardless of whether or not the addressee can be expected to already have an existing representation in memory beforehand. This restriction can be met by entities that are already familiar (regardless of how they became familiar), including ones

that are also activated and/or in focus, as in (22), since anything familiar, activated or in focus is by definition also uniquely identifiable.

(22) A. Oh. So you've only known the dog how long did you say?

B. Well, about a year, I guess.

A: Oh well. Is it, uh, how old is the dog? (Switchboard corpus)

But the cognitive status restriction on appropriate use of the definite article can also be met by entities for which a new unique representation can be constructed, either by way of a bridging inference to a recently activated entity (as in (12) or (13) above), or on the basis of descriptive content encoded in the phrase alone, as is the case for the phrase *the maximum number of boxcars of oranges that I can get to Bath by 7 a.m. tomorrow morning* in (23).

(23) I want t- I want to determine the maximum number of boxcars of oranges that I can get to Bath by 7 a.m. tomorrow morning ...[Trains Corpus. Heeman & Allen 1995]

The various mappings between referring forms and cognitive statuses thus fall out automatically if cognitive status values for different determiners and pronouns are represented/constrained in the grammar, as suggested in the previous section. However, distribution of forms across statuses that meet necessary conditions for appropriate use is not random. Some forms are rarely used, even when necessary conditions for use are met. For example, since the indefinite article only requires type identifiability it should, in principle, be appropriate to use this form for all statuses. In fact, however, the indefinite article is rarely used for statuses higher than 'referential'. Traditional accounts of the difference between definite and indefinite determiner use have accounted for such facts by assuming that non-familiarity (and non-uniqueness) is part of the conventional meaning of the indefinite article. Gundel et al (1993) propose, instead, that the association of indefiniteness with non-familiarity follows from interaction of the conventional meaning of the indefinite article (i.e. type identifiability) with the first part of the Quantity Maxim (make your contribution as informative as appropriate).⁵ Since, in most cases, it would be informative (and relevant) to the addressee to know whether or not there is an intended referent that she can uniquely identify, use of the indefinite article (which is unspecified for any status above 'type identifiable') would normally implicate that the addressee cannot

⁵ An alternative formulation is proposed in Green (2000: 117) – “An agent will do as much as is required for the achievement of the current goal.”

uniquely identify the referent.⁶

Similarly, Gundel et al argue, demonstrative pronouns, which require only activation, often implicate that the referent is not in focus, which accounts for their relatively infrequent use compared to the personal pronoun. Demonstrative pronouns are typically used only when conditions for using the more restrictive (hence more informative) pronoun, *it*, are not met. Compare (24) and (25), for example.

(24) Anyway, going back from the kitchen then is a little hallway leading to a window. Across from the kitchen is a big walk-through closet. And next to it,

(25) Anyway, going back from the kitchen then is a little hallway leading to a window. Across from the kitchen is a big walk-through closet. And next to that...

It in (24) is most naturally interpreted as referring to the kitchen, not the hallway or the closet. This is as predicted by the cognitive status constraint on unstressed personal pronouns, namely that their referent must be in focus. Since the kitchen, unlike the hallway and the closet, is the focal point for the description and has been mentioned twice, it is likely to be in focus at the point when the pronoun is encountered. In (25), on the other hand, the demonstrative *that* is interpreted as referring to the closet, which is activated, but not yet in focus. It is not interpreted as referring to the kitchen, even though the kitchen meets necessary conditions for using a demonstrative pronoun, since anything in focus is also activated. Thus, just as the indefinite article, which is unspecified for statuses above type identifiable, implicates that the referent is not uniquely identifiable, a demonstrative pronoun, which is unspecified for the status 'in focus', typically implicates that the referent is not already in focus, i.e. it implicates a focus shift.

Use of a weaker, less restrictive form doesn't always implicate that a stronger form would not have been licensed, however. For example, the definite article doesn't implicate non-familiarity. As noted above, it is typically used for familiar, and even activated and in focus entities. Gundel et al argue that this is because scalar implicatures arise only when the information that would be conveyed by the stronger form is relevant. For full definite NPs, signaling that the addressee can uniquely identify the

⁶ Note that use of the indefinite article does not implicate non-referentiality. This is because there is no generally available form in English which explicitly signals referentiality, as indefinite 'this' is restricted to casual speech. The determiner *a* is therefore the most informative choice when the cognitive status is 'referential', but not 'uniquely identifiable.'

referent is usually sufficient to allow her to interpret it (given the descriptive content of the NP); so the extra information about cognitive status provided by the demonstrative is typically necessary only in cases like the ‘pareiasaurs’ example in (4), where the descriptive content is insufficient to allow the addressee to identify the referent. This also explains the relative infrequency of demonstrative determiners as compared to the definite article (see Gundel, Hedberg and Zacharski 1993, 2000 and Gundel and Mulhern 1998 for more detailed discussion.).

Facts like the ones discussed above follow from interaction of the Givenness Hierarchy (specifically constraints on the cognitive statuses signaled by different forms) with general pragmatic principles. As such, they do not have to be directly represented in the grammar, e.g. by constraining the indefinite article so that it refers only to non-familiar entities or demonstrative pronouns so they do not refer to entities in focus. In fact, imposing such restrictions would make incorrect predictions in examples like (26), where *that* refers to the ‘in focus’ kitchen or (27), where *a student of yours* clearly does not refer to someone the addressee is not already familiar with.

(26) John’s kitchen is really cozy. That’s my favorite room in the house.

(27) A student of yours came to see me today.

4. Conclusion

I have distinguished here two distinct senses of givenness/newness, one referential and the other relational, and have discussed facts relating to the referential givenness notion of cognitive status, demonstrating the relevance of this notion for the distribution and interpretation of different forms of referring expression. Some of these facts can be accounted for by directly incorporating cognitive status into the grammar, specifically as a constraint on specific lexical items (determiners and pronouns). These include, among other things, the fact that determiners and pronouns are not sensitive to whether or not a referent has been linguistically introduced; the infelicity of unstressed personal pronouns in referring to entities not in the addressee’s focus of attention; and use of the definite article in referring to non-familiar, but still uniquely identifiable, entities, as well as entities that are not only familiar, but also in focus. Other facts, I have argued, can be attributed to interaction of the language system with non-linguistic principles that govern information processing and therefore do not need to be directly represented in the grammar. These include association of the indefinite article with non-familiarity; association of demonstrative pronouns with focus shift; and the fact that unstressed personal pronouns are more likely to refer to entities that have been

linguistically introduced in a syntactically prominent (e.g. subject) position. In a forthcoming article (Gundel, in preparation), I argue that the situation is similar for facts having to do with such relational givenness notions as topic and focus. These are linguistic concepts, which play a role in the syntax, morphology and phonology of natural languages. As such, they clearly belong in the grammar. But interpretive aspects of these concepts such as familiarity or salience conditions on topics and the 'new information' effect of focus follow from general pragmatic principles, and do not belong in the grammar.⁷

References

- Ariel, Mira. 1988. Referring and accessibility. *Journal of Linguistics* 24:67-87.
- Birner, Betty J. and Gregory Ward. 1998. *Information Status and Noncanonical Word Order in English*. Amsterdam: John Benjamins.
- Byron, Donna and James Allen. 1998. Resolving demonstrative pronouns in the TRAINS93 corpus. In the Proceedings of the Second Colloquium on Discourse Anaphora and Anaphor Resolution (DAARC-2), 68-81.
- Chafe, Wallace L. 1976. Givenness, contrastiveness, subject, topic, and point of view. In C. Li, (ed.), *Subject and Topic*. New York: Academic Press.
- Chafe, Wallace L. 1994. *Discourse, Consciousness, and Time*. Chicago University Press.
- Chomsky, Noam. 1971. Deep structure, surface structure and semantic interpretation. In D. Steinberg and L. Jakobovits (eds.), *Semantics, an Interdisciplinary Reader in Linguistics, Philosophy and Psychology*, 183-216, Cambridge: Cambridge University Press.
- Clark, Herbert . and Susan D. Haviland. 1977. Comprehension and the given new contract. In R. Freedle (ed.) *Discourse Production and Comprehension*. Norwood, N.J.: Ablex, 1-40.
- Erteschik-Shir, Nomi. 1997. *The Dynamics of Focus Structure*. Cambridge University Press.
- Fodor, Janet D., and Ivan Sag. 1982, Referential and quantificational indefinites. *Linguistics and Philosophy* 5.355-398.
- Fraurud, Kari. 1990. Definiteness and processing of NPs in natural discourse. *Journal of Semantics* 7:395-433.
- Gabelenz, G. von der. 1868. Ideen zur einer vergleichenden Syntax: Wort und Satzstellung. *Zeitschrift für Völkerpsychologie und Sprachwissenschaft*.6:376-384.

⁷ See also Gundel 1999b for some preliminary discussion of these points.

- Green, Georgia. 2000. The nature of pragmatic information. In Ronnie Cann, Clair Grover and Phillip Miller (eds.) *Grammatical Interfaces in HPSG*. Stanford, CSLI.
- Green, Georgia. 1997. The structure of CONTEXT: the representation of pragmatic restrictions in HPSG. In James Yoon (ed.), *Proceedings of the 5th Annual Meeting of the Formal Linguistics Society of the Midwest*. Studies in the Linguistic Sciences, .
- Gundel, Jeanette K. 1974. *The Role of Topic and Comment in Linguistic Theory*. Ph.D.Dissertation, University of Texas at Austin. Published by Garland, 1989.
- Gundel, Jeanette K. 1980. Zero NP-anaphora in Russian: a case of topic-prominence. In *Proceedings from the 16th Meeting of the Chicago Linguistic Society. Parasession on Anaphora*, pp. 139-146.
- Gundel, Jeanette K. 1988. Universals of topic-comment structure In M. Hammond, E. Moravczik and J. Wirth (eds.), *Studies in Syntactic Typology*, 209-239, Amsterdam:John Benjamins, 209-239..
- Gundel, Jeanette K. 1996. Relevance theory meets the Givenness Hierarchy: an account of inferrables. In J. Gundel and T. Fretheim, (eds.), *Reference and Referent Accessibility*.Amsterdam: John Benjamins.
- Gundel, Jeanette K. 1999a. On different kinds of focus. In P. Bosch and R. van der Sandt (eds.), *Focus in Natural Language Processing*, 293-305, Cambridge: Cambridge Univ. Press.
- Gundel, J. K. 1999b. Topic, focus, and the grammar-pragmatics interface. In J. Alexander, N-R. Han, and M.M. Fox (eds.) *Proceedings of the 23rd Annual Penn Linguistics Colloquium*. University of Pennsylvania Working Papers in Linguistics 6.1:185-200.
- Gundel, Jeanette K. In preparation. Information Structure: How much belongs in the grammar?
- Gundel, Jeanette K., Nancy Hedberg, Ron Zacharski. 1988. The generation and interpretation of demonstrative expressions. *Proceedings of the XIIth International Conference on Computational Linguistics*. John Von Neumann Society for the Computing Sciences, Budapest, 216-221.
- Gundel, Jeanette K., Nancy Hedberg, Ron Zacharski. 1993. Cognitive status and the form of referring expressions in discourse. *Language* 69:274-307.
- Gundel, J. K., N, Hedberg and R, Zacharski. 2001. Definite descriptions and cognitive status in English:why accomodation is unnecessary. *Journal of English Language and Linguistics* 5.2:273-95.
- Gundel, Jeanette K. and Ann Mulkern. 1998. Reference and scalar implicatures *Pragmatics and Cognition*. Special issue on the Concept of Reference in the Cognitive Sciences.

- Gundel, Jeanette K., Kaja Borthen and Thorstein Fretheim. 1999. The role of context in pronominal reference to higher order entities in English and Norwegian. In P. Bouquet et al, eds. *Modeling and Using Context.. Proceedings from the Second International and Interdisciplinary Conference, CONTEXT '99*. Lecture Notes in Artificial Intelligence 1688. Springer.
- Gundel, Jeanette K., Michael Hegarty and Kaja Borthen. 2003. Cognitive Status, Information Structure, and Pronominal Reference to Clausally Introduced Entities. *Journal of Logic, Language and Information* 12:281-299.
- Gundel, Jeanette K. and Thorstein Fretheim. 1993. Topic and Focus. In G. Ward and L. Horn (eds.) *Handbook of Pragmatics*. London:Blackwell.
- Halliday, M.A.K. 1967. Notes on transitivity and theme in English. Part II. *Journal of Linguistics* 3:199-244.
- Hedberg, Nancy. 1990. *Discourse pragmatics and cleft sentences in English*. Minneapolis, MN: University of Minnesota dissertation
- Hedberg, Nancy. 2000. The referential status of clefts. *Language* 76: 891-920.
- Hegarty, Michael, Jeanette K. Gundel, and Kaja Borthen. 2002. Information structure and the accessibility of clausally introduced referents. *Theoretical Linguistics*, pp. 1-24.
- Heim, Irena R. 1982. The semantics of definite and indefinite noun phrases. Amherst: University of Massachusetts dissertation.
- Jackendoff, Ray. 1972. *Semantic Interpretation in Generative Grammar*. Cambridge: MIT Press.
- Jackendoff, Ray. 2002. *Foundations of Language*. Oxford University Press.
- Kuno, Susumu. 1972. Functional sentence perspective. *Linguistic Inquiry* 3.3, 269-320.
- Lambrecht, Knud. 1994. *Information Structure and Sentence Form: Topic, Focus and the Mental Representation of Discourse Referents*. Cambridge University Press.
- Mathesius, V. 1928. On linguistic characterology with illustrations from Modern English. *Actes du Premier Congrès International de Linguistes à La Haye*, pp. 56-63.
- Poesio, Massimo and Renate Vieira. 1998. A corpus-based investigation of definite description use. *Computational Linguistics* 24:183-216.
- Pollard, Carl and Ivan Sag. 1994. *Head-Driven Phrase-Structure Grammar*. University of Chicago Press.
- Prince, Ellen F. 1978. A comparison of *wh*-clefts and *it*-clefts in discourse. *Language* 54:883-906.
- Prince, Ellen F. 1981. Towards a taxonomy of given-new information. In P. Cole (ed.), *Radical Pragmatics*. New York:Academic Press.

- Prince Ellen F. 1992. The ZPG letter: subjects, definiteness, and information status. In S. Thompson and W. Mann (eds.), *Discourse Description: Diverse Analyses of a Fund Raising Text*. Amsterdam:John Benjamins , 295-325.
- Reinhart, Tanya 1981. Pragmatics and linguistics. An analysis of sentence topics.*Philosophica* 27:53-94.
- Sgall, Petr, E. Hajišova and E. Benešova. 1973. *Topic, Focus, and Generative Semantics*. Kronberg: Scriptor Verlag GmbH.
- Sgall, Petr, E. Hajišova , J. Panevová. 1986. *The meaning of the sentence in its semantic and pragmatic aspects*. Dordrecht: Reidel.
- Sperber, Dan, Deirdre Wilson. 1986/95. *Relevance: Communication and Cognition* . London:Blackwell.
- Strawson, P.F. 1964. Identifying reference and truth values. *Theoria* 3.96-118.
- Vallduví, Enric. 1992. *The Informational component*. New York:Garland.
- Vallduví, Enric and Elisabet Engdahl. 1996. The linguistic realization of information packaging. *Linguistics* 34:459-519.
- Webber, Bonnie L. 1988. "Discourse deixis and discourse processing." Technical report, University of Pennsylvania.
- Webber, Bonnie. L. 1991. "Structure and ostension in the interpretation of discourse deixis." *Language and Cognitive Processes* 6.2:107-135.

A constraint-based approach to information structure and prosody correspondence

Mohammad Haji-Abdolhosseini

University of Toronto

Proceedings of the 10th International Conference on
Head-Driven Phrase Structure Grammar

Michigan State University

Stefan Müller (Editor)

2003

Stanford, CA: CSLI Publications

pages 143–162

Haji-Abdolhosseini, Mohammad. 2003. A constraint-based approach to information structure and prosody correspondence. In Stefan Müller (ed.), *Proceedings of the 10th International Conference on Head-Driven Phrase Structure Grammar, Michigan State University*, 143–162. Stanford, CA: CSLI Publications. DOI: 10.21248/hpsg.2003.9.



Abstract

This paper provides a constraint-based account of information-prosody correspondence within the HPSG framework. The starting point of the paper is Klein's (2000) account of prosodic constituency in HPSG. However, it departs from the standard syntactocentric architecture of grammar, and adopts a grammar design in which syntax, phonology, and information structure are generated in parallel, with all three applying to a common list of domain objects. It is shown that this theoretical architecture elegantly captures many of the various constraints that have been shown to hold in classical views of grammar.

1 Introduction¹

For several years, the main preoccupation of researchers working in constraint-based theories of grammar such as HPSG has been syntax and to some extent semantics. It is only in the past few years that we find work being done within phonology and its interfaces with other components of the theory. Some notable examples of such work in the HPSG framework are (Asudeh and Mikkelsen, 2000; Bird, 1990, 1995; Bird and Klein, 1991; Höhle, 1999; Klein, 2000; Yoshimoto, 2000). It has been shown that unification-based approaches are not only compatible with work in phonology as well as grammatical interfaces, but also at times they are better alternatives to derivational frameworks. Thus, it seems only natural that one would want to pursue this line of inquiry in order to explore its potential rewards to the field.

Recently, proponents of Combinatory Categorical Grammar (CCG) (Steedman, 1991, 2000b; Prevost and Steedman, 1994; Prevost, 1995) have been promoting an approach relying on the premise that surface structure is isomorphic to prosodic structure. A central claim of CCG is that by making use of elaborate type-raising and abstraction operators in a single component, one arrives at a theory that is simpler and more restricted than a multi-partite theory whose layers interact at interfaces. Although CCG can make very interesting predictions, its implications for cross-linguistic data, especially from non-configurational languages have not yet been explored and thus are largely unknown. In addition, more modular linguistic theories have been argued to model human language and other cognitive faculties more closely. Jackendoff (1997, 2002), for example, argues for a tripartite architecture of grammar where phonological, morpho-syntactic and semantic components work in parallel and only meet at interface levels.

Moreover, there are also practical reasons that it is important to do research in grammatical interfaces in constraint-based and multi-partite frameworks. A modular theory is easier for the researcher to work with. A grammar written in this ap-

¹I would like to thank Elizabeth Cowper, Dave McKercher, and Gerald Penn for their valuable comments and discussions. I am also grateful to three anonymous reviewers for the 10th International Conference on Head-Driven Phrase Structure Grammar for their useful comments and their suggested references. Any oversights or shortcomings, however, are solely my responsibility.

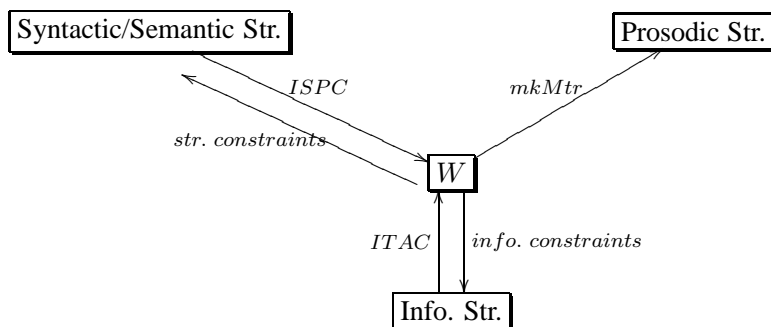

Figure 1: Architecture of the information-based model of prosodic constituency

proach is certainly more readable and more convenient to maintain. Furthermore, with the emergence of large-scale HPSG grammars a modular approach becomes more significant to promote code readability and reuse.

From a computational standpoint the significance of the interactions between phonology and other components of grammar is becoming more and more evident to the computational linguistics community as we observe a shift of focus from text-to-speech (TTS) to concept-to-speech (CTS) system. A predictable intonation created based on syntactic criteria no longer seems to fully meet the conversational needs of a dialogue system. More natural-sounding systems are being sought that adapt their intonation to their context.

This paper lays down the groundwork for a unification-based model of prosody that is sensitive to the syntax and information structure of the sentence. The approach adopted is a more modular one in the spirit discussed above. The theory developed here derives syntactic and prosodic structures at different layers interacting at interfaces only. The model of prosodic constituency laid out here is no longer syntax-driven. Prosodic structure is defined in parallel with syntactic structure over a list of domain objects² commonly accessed from syntax, phonology, and information structure. The architecture of this information-based and modular model of prosody is depicted in Figure 1. According to this model, the syntactic/semantic, prosodic and information structures are all constructed from a unique list of lexical items, W . The arrows pointing from W to various structures represent well-formedness constraints on those structures. The arrows that point back to W represent constraints on the features of the members of W imposed by those structures. Structural constraints are basically those found in standard HPSG literature such as the rule schemata and the like. Informational constraints define well-formed information structures. We do not discuss these in this paper. ISPC, ITAC and mkMtr are discussed in detail in section 3 where the formal account of the data is presented.

²Domain objects in this paper are assumed to be lexical items as a starting point. Therefore, they differ from the domain objects introduced by Kathol (1995, 2000); Reape (1994). However, the exact nature of the domain objects in this approach is an open question.

Further motivation for adopting the architecture presented in Figure 1 comes from the myriad mismatches observed between syntactic and prosodic structures. As Zwicky (1982) puts it, “[t]he divergence between the syntactic and phonological organizations of the same material has long been recognized as a problem in analysis and a challenge to theorizing, finding recognition in works as diverse as Kahane and Beym (1948); Pulgram (1970); Bing (1970); Cooper and Paccia-Cooper (1980) and the writing of the ‘metrical phonologists’, in particular Selkirk (1981).” Basically, the mainstream literature assumes that the prosodic structure mirrors syntactic structure unless otherwise specified in order to satisfy certain phonological constraints. These constraints, however, render virtually every prosodic structure different from the syntactic structure of the same sentence. For example, invariably in every Det, Adj, N sequence, the Adj gets “promoted” to the sister of Det giving rise to the following prosodic structure [[Det Adj] N] which is different from the syntactic structure [Det [Adj N]]. The modular model proposed in this paper accounts for the phenomena that Butt and King (1998) call “prosodic promotion”, and “prosodic flattening” straightforwardly without having to manipulate syntactic structures. In addition, information structure-prosody correspondence is handled elegantly in a modular fashion without recourse to unnecessary and *ad hoc* operations and/or levels of representation. This approach allows for the extension of the model to straightforwardly account for word-order variations as well.

As it stands, this paper can be thought of as a response to the CCG claim that modular theories are overly complicated and unconstrained. It is our claim that by making use of sufficient constraints on each module, we *can* have a theory with very simple sub-components that are more readable, extensible, and maintainable. The analysis here builds on ideas proposed in Klein (2000), but departs from the syntactocentric approach adopted in that work.

Section 2 goes over the data that is to be accounted for. As mentioned earlier, section 3 presents a formal account of the data. For some background information on the issues discussed here, refer to Klein (2000); Selkirk (1984); Zwicky (1982) and the references therein.

2 Data

Let us go over some examples to illustrate the empirical coverage of Klein’s interface model. Starting with (1), we can see how the application of mkMtr results in a correct derivation of a prosodic tree.

- (1) I want to begin to try to write a play.

Stepping into the derivation bottom-up and right-to-left, we can easily trace the working of mkMtr. For example, *a play* is a *hd-spr-cx* and thus also of type *ext-pr*, which employs mkMtr_{LA} according to Klein (2000). As shown in (2), the application of mkMtr_{LA} to *a play* results in a metrical tree of type *mtr(lnr)*.

$$(2) \text{ mkMtr}_{\text{LA}}(\langle a, \text{play} \rangle) = \text{mkMtr}^{\text{full}}(\text{mkMtr}^{\text{lnr}}(\langle a, \text{play} \rangle) \oplus \langle \quad \rangle) =$$

$$\text{mkMtr}^{\text{full}} \left(\left\langle \left[\begin{array}{c} \text{mtr}(\text{lnr}) \\ \text{DOM} \\ \text{DTE} \end{array} \right] \left\langle a, \boxed{\text{I}} \text{play} \right\rangle \right\rangle \right) = \left[\begin{array}{c} \text{mtr}(\text{lnr}) \\ \text{DOM} \\ \text{DTE} \end{array} \right] \left\langle a, \boxed{\text{I}} \text{play} \right\rangle$$

Going through the derivation procedurally in the same manner yields the result shown in (3). The following example is frequently mentioned by Steedman (e.g. Steedman, 2000b, 94) as one that needs to be accounted for by any theory that deals with syntax-phonology mismatches.

- (3) [(I want) [(to begin) [(to try) [(to write) (a play)]]]]]
 (4) * [[I want to begin to][try to write a play]]

In this example a pause has been placed between a leaner and the prosodic word that it leans on. Clearly, a pause should not be allowed to intervene within leaner groups and we should make provisions in our theory to reject such ill-formed structures.

Klein's account incorrectly marks (5) ungrammatical as *I*, being a personal pronoun is considered a leaner in that model.

- (5) [I] [want to begin to try to write a play].

The sentences in (5) and (6) appear in Steedman (2000b, 93). He suggests a model of syntax whose surface structures correspond directly to intonational contours. Thus, in these examples, all of the observed intonational contours correspond to alternate surface structures for the sentence in a CCG framework.

- (6) a. [I want][to begin to try to write a play].
 b. [I want to begin][to try to write a play].
 c. [I want to begin to try][to write a play].
 d. [I want to begin to try to write][a play].

In our framework, we would like to develop a model that not only is able to account for these alternate intonational contours and their corresponding semantics, but also maintains the modularity of its component theories as much as possible. Another example that Steedman (2000b), *inter alia*, discusses is (7).

- (7) *[Three mathematicians] [in ten prefer margarine].

Selkirk (1984) attributes the ungrammaticality of (7) to the violation of the Sense Unit Condition, meaning that the prepositional phrase *in ten* and the verb phrase *prefer margarine* fail to form a sense unit as neither is a complement or modifier of the other. Steedman's CCG model accounts for this. Again, approaching the problem from our standpoint, we would like a multi-partite account for this fact. Another type of data that we want to account for here is:

- (8) a. [Jane gave the book to Mary]
 b. [Jane] [gave the book to Mary]
 c. [Jane gave the book] [to Mary]
 d. [Jane gave] [the book] [to Mary]
 e. * [Jane] [gave] [the book to Mary]
 f. * [Jane gave] [the book to Mary]
 g. [Jane] [gave the book] [to Mary]
 h. [Jane] [gave] [the book] [to Mary]

These data have been discussed in Selkirk (1984), and similar examples have been talked about in Steedman (2000a). Selkirk (1984) also attributes the ungrammaticality of (8e, f) to the violation of the Sense Unit Condition: The phrases *the book* and *to Mary* do not form a sense unit because neither is a complement or modifier of the other.

3 Analysis

3.1 Information Status and Intonation

Like Steedman, who adopts a Hallidayan tradition, we use the term *theme* to refer to given information and *rheme* to new information.³ Steedman (2000b, 101), following Pierrehumbert (1980), attributes L+H* LH% intonation contour to theme and H*LL% to rheme. L+H* LH% and H*LL% are in Pierrehumbert's notation (Pierrehumbert, 1980), and respectively correspond to *rise-fall-rise* and *fall* intonation in British style (Ladd, 1996, 82). Going back to our example about writing a play (extended here as (9)), we can discuss some of the interaction between information structure and prosody. Hereafter, θ stands for *theme* and ρ for *rheme*.

- (9) a. [I] θ [want [(to begin) [(to try) [(to write) (a play)]]]]] ρ
 L+H* LH% H*LL%
- b. [(I want)] θ [(to begin) [(to try) [(to write) (a play)]]]]] ρ
 L+H* LH% H*LL%
- c. [(I want) (to begin)] θ [(to try) [(to write) (a play)]]] ρ
 L+H* LH% H*LL%
- d. [(I want) (to begin) (to try)] θ [(to write) (a play)]] ρ
 L+H* LH% H*LL%

³Other terms used in the partitioning of information include (*back*)*ground/focus*, and *topic/comment* among others. For the purposes of this paper, we assume that all of these correspond to *given/new* information. Steedman (2000b) makes a distinction between *background/focus* and *theme/rheme*. For him, *theme* or *rheme* can be partitioned into *background* and *focus*. In this account, the DTE can be thought of Steedman's *focus* and whatever that is not a DTE can be considered as *background*. For a survey of literature on information packaging, see Vallduví and Engdahl (1996).

(10) **Appropriateness Constraint on *sign***

<i>sign</i>	
PHON	<i>pros</i>
SYNSEM	<i>synsem</i>
DOM	<i>list(dom-obj)</i>
INFO	<i>list(info)</i>

Type *info* has two subtypes: *marked-info* and *unmarked-info*. The type *marked-info* itself subsumes *theme* and *rheme*.

(11) **Informational Types:**

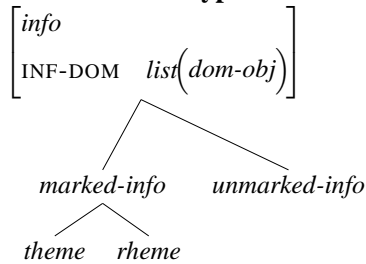

(12) **Tonal Types:**

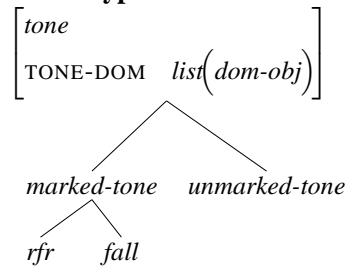

In the prosody partition, we need a place to record the tonal information. Therefore, we add the feature TONE to $mtr(\tau)$. Feature TONE takes as its value a list of *tone* objects, which have the following subtypes: *marked-tone* and *unmarked-tone*. The type *marked-tone* (at least) subsumes *rfr*, which stands for rise-fall-rise (L+H* LH%) intonation, and *fall*, which stands for falling (H*LL%) intonation (see (12)). Our revised prosodic type hierarchy takes the form shown in Figure 2.

Another point to discuss here is Klein’s type hierarchy of phrases that cross-classify prosodic phrases under syntactic phrases. What that hierarchy assumes is that all syntactic phrases match some prosodic phrase in their yield. While this is a logical starting point since syntactic trees and prosodic trees often look very similar, even isomorphic in some cases, they clearly are not the same as we observe in the data above and in the literature. Sometimes prosodic phrases do not correspond to any syntactic constituent and vice versa. In our move towards a tripartite architecture, we should therefore treat these two types of constituency differently. Klein’s approach is heavily syntax-driven and involves making prosodic trees by manipulating syntactic trees. What we need to do instead is to modify mkMtr such that it declaratively defines prosodic trees without the need to refer to syntax. This will also simplify mkMtr as we shall see shortly. What this means for the type hierarchy of *phrase* types is that phrases are no longer cross-classified with respect to the two dimensions headedness and prosody. Prosodic structure is defined over the list of domain objects as opposed to a list of partial prosodic structures. Figure 3 presents the type hierarchy of phrases that we assume in this paper.

A constraint is now required to associate the tones introduced in (12) with the information that they convey. This constraint has to be declared for any object of

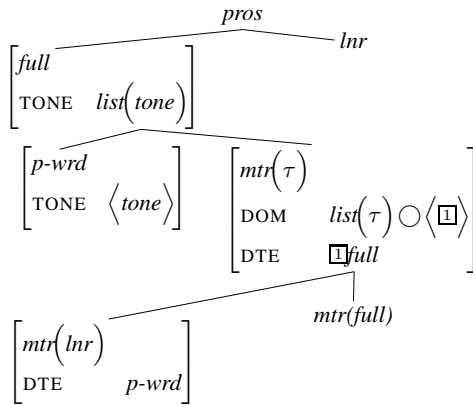

Figure 2: Prosodic Type Hierarchy

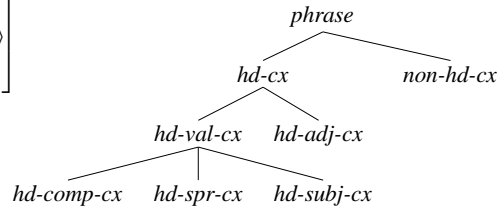

Figure 3: Type hierarchy of phrasal constructions

type *word*. This can be regarded as an interface point between conceptual structure and phonological structure in Jackendoff’s terms. The constraint, which is called the *Information-Tone Association Constraint (ITAC)*, is formulated in Figure (4). The first disjunct in (4) relates theme with the *rise-fall-rise* (L+H* LH%) intonation. The second disjunct relates rheme with *falling* (H*LL%) intonation, and the third one is the default situation where lexical items are left unmarked with regard to their information status and tone. The last disjunct states that some *word* objects are prosodically leaners.

3.3 The mkMtr Function Revisited

We now need to revise the mkMtr function to handle the new formalism. Before we do that, however, let us go over the type of change that needs to be made. Take the examples in (13).

- (13) a. [Jane [drank milk]]
 b. [[Jane drank] milk]

In (13a), *Jane* is the theme and *drank milk* the rheme; whereas, in (13b), *Jane drank* is the theme and *milk* the rheme. (13a) is compatible with the Prosodic Isomorphism Hypothesis (PIH) but (13b) is not. *Jane* and *drank* form their own prosodic constituent because they both correspond to the theme of the sentence and *milk* belongs to a different prosodic constituent because its informational status is different. Therefore, what we want mkMtr to do is to relate prosodic structure and information structure. What this amounts to theoretically is that a weak form of PIH in this model holds for prosody and information structure as opposed to syntactic structure.

$$\begin{array}{c}
\text{word} \Rightarrow \left[\begin{array}{c} \text{PH} \left[\begin{array}{c} p\text{-wrd} \\ \text{TONE} \left\langle \left[\begin{array}{c} rfr \\ \text{T-DOM} \langle \mathbb{1} \rangle \end{array} \right] \right\rangle \end{array} \right] \\ \text{DOM} \langle \mathbb{1} \rangle \\ \text{INFO} \left\langle \left[\begin{array}{c} theme \\ \text{I-DOM} \langle \mathbb{1} \rangle \end{array} \right] \right\rangle \end{array} \right] \vee \left[\begin{array}{c} \text{PH} \left[\begin{array}{c} p\text{-wrd} \\ \text{TONE} \left\langle \left[\begin{array}{c} fall \\ \text{T-DOM} \langle \mathbb{1} \rangle \end{array} \right] \right\rangle \end{array} \right] \\ \text{DOM} \langle \mathbb{1} \rangle \\ \text{INFO} \left\langle \left[\begin{array}{c} rheme \\ \text{I-DOM} \langle \mathbb{1} \rangle \end{array} \right] \right\rangle \end{array} \right] \vee \\
\left[\begin{array}{c} \text{PH} \left[\begin{array}{c} p\text{-wrd} \\ \text{TONE} \left\langle \left[\begin{array}{c} unmarked\text{-tone} \\ \text{T-DOM} \langle \mathbb{1} \rangle \end{array} \right] \right\rangle \end{array} \right] \\ \text{DOM} \langle \mathbb{1} \rangle \\ \text{INFO} \left\langle \left[\begin{array}{c} unmarked\text{-info} \\ \text{I-DOM} \langle \mathbb{1} \rangle \end{array} \right] \right\rangle \end{array} \right] \vee [\text{PH } lnr]
\end{array}$$

Figure 4: Information-Tone Association Constraint (ITAC)

(14) **The mkMtr Function (Revised)**

- a. $\text{mkMtr} : list(pros) \mapsto mtr(pros)$
 $\text{mkMtr}(\mathbb{1}) = \text{mkMtr}^{full}(mkAllLnrs(\mathbb{1}))$
- b. $\text{mkMtr}^{\tau \leq pros} : list(pros) \mapsto mtr(\tau)$
 $\text{mkMtr}^{\tau} \left(\left\langle \left[\text{PHON } \mathbb{1} pros \right] \right\rangle \right) = \mathbb{1}$
- c. $\text{mkMtr}^{lnr} : list(pros) \mapsto mtr(pros)$

$$\text{mkMtr}^{lnr} \left(\left\langle \left[\mathbb{2} lnr, \dots, \mathbb{n} lnr, \mathbb{m} \left[\begin{array}{c} p\text{-wrd} \\ \text{TONE } \mathbb{3} \end{array} \right] \right] \right\rangle \right) = \left[\begin{array}{c} mtr(lnr) \\ \text{DOM} \langle \mathbb{2}, \dots, \mathbb{n}, \mathbb{m} \rangle \\ \text{DTE } \mathbb{m} \\ \text{TONE} \langle \mathbb{3} \rangle \end{array} \right]$$

- d. $\text{mkMtr}^{full} : list(pros) \mapsto mtr(full)$

i. $\text{mkMtr}^{full} \left(\left\langle \left[\mathbb{1} \left[\text{TONE} \langle \mathbb{3} \rangle \right], \mathbb{2} \left[\text{TONE} \langle \mathbb{3} \rangle \right], \dots, \mathbb{n} \left[\text{TONE} \langle \mathbb{3} \rangle \right] \right] \right\rangle \right) =$

$$\left[\begin{array}{c} mtr(full) \\ \text{DOM} \langle \mathbb{1}, \mathbb{2}, \dots, \mathbb{n} \rangle \\ \text{DTE } \mathbb{n} \\ \text{TONE} \langle \mathbb{3} \rangle \end{array} \right]$$

$$\begin{aligned}
\text{ii. } \text{mkMtr}^{full}(\mathbb{1} \oplus \mathbb{2} \oplus \dots \oplus \mathbb{m}) &= \left[\begin{array}{l} \text{mtr}(full) \\ \text{DOM} \quad \langle \mathbb{5}, \mathbb{6}, \dots, \mathbb{a} \rangle \\ \text{DTE} \quad \mathbb{a} \\ \text{TONE} \quad \langle \mathbb{3}, \mathbb{4}, \dots, \mathbb{m} \rangle \end{array} \right] \wedge \\
\mathbb{1} &= \left\langle \left[\text{TONE} \quad \mathbb{3} \right], \dots, \left[\text{TONE} \quad \mathbb{3} \right] \right\rangle \wedge \\
\mathbb{2} &= \left\langle \left[\text{TONE} \quad \mathbb{4} \right], \dots, \left[\text{TONE} \quad \mathbb{4} \right] \right\rangle \wedge \dots \wedge \\
\mathbb{m} &= \left\langle \left[\text{TONE} \quad \mathbb{m} \right], \dots, \left[\text{TONE} \quad \mathbb{m} \right] \right\rangle \wedge \\
\mathbb{3} &\neq \mathbb{4} \neq \dots \neq \mathbb{m} \wedge \\
\text{mkMtr}^{full}(\mathbb{1}) &= \mathbb{5} \wedge \text{mkMtr}^{full}(\mathbb{2}) = \mathbb{6} \wedge \dots \wedge \text{mkMtr}^{full}(\mathbb{m}) = \mathbb{a}
\end{aligned}$$

The new *mkMtr* function is used in a constraint on *sign* objects as formalised in (16). The function *collect-phon* that is defined below in (15) and used in (16) takes a list of domain objects and returns a list of the PHON values of those objects. Theoretically, relations like *collect-phon* not only ensure the correct input type to other relations or modules of the grammar, they are also ideal in restricting access. In this case, *collect-phon* allows phonology to only see the phonological data inside DOM. Except for the interface constraints (such as ITAC, and ISPC), nothing from phonology can access the data in the syntactic/semantic, or information-structural modules.

We no longer make use of *base-pr* and *ext-pr*; rather, we let what has been described as prosodic flattening and prosodic promotion follow naturally from general constraints on prosody and information structure.

$$\begin{aligned}
(15) \quad \text{collect-phon} : \text{list}(\text{dom-obj}) &\mapsto \text{list}(\text{pros}) \\
\text{a. } \text{collect-phon}(\langle \rangle) &= \langle \rangle \\
\text{b. } \text{collect-phon}(\langle \mathbb{1} \mid \mathbb{2} \rangle) &= \langle [\text{PHON } \mathbb{1}] \mid \text{collect-phon}(\mathbb{2}) \rangle
\end{aligned}$$

$$(16) \quad \text{sign} \Rightarrow \left[\begin{array}{l} \text{PHON} \quad \text{mkMtr}(\text{collect-phon}(\mathbb{1})) \\ \text{DOM} \quad \mathbb{1} \end{array} \right]$$

$$\begin{aligned}
(17) \quad \text{mkAllNrs} : \text{list}(\text{pros}) &\mapsto \text{list}(\text{pros}) \\
\text{a. } \text{mkAllNrs}(\mathbb{1} \oplus \mathbb{2} \oplus \mathbb{3}) &= \text{mkAllNrs}(\mathbb{1} \oplus \langle \text{mkMtr}^{lnr}(\mathbb{2}) \rangle \oplus \mathbb{3}) \\
\text{b. } \text{mkAllNrs}(\mathbb{1}) &= \mathbb{1}
\end{aligned}$$

(14a) is the top-level function called by *sign* objects. It uses the *mkAllNrs* function defined in (17) to generate all the possible leaner groups in the list of domain objects, and passes the resulting mixed list of leaner groups and prosodic words to *mkMtr*^{full} to generate a complete prosodic structure for the original list of domain objects.

(14b) is essentially the same as before. It simply returns a singleton argument intact because a metrical tree requires at least two daughters. (14c), similar to the

$$\begin{array}{l}
hd-cx \Rightarrow \left[\begin{array}{l}
\text{HD-DTR } \boxed{1} \left[\begin{array}{l}
\text{PH } \left[\begin{array}{l}
p\text{-}wrd \\
\text{TONE } \langle \boxed{2}tone \rangle \end{array} \right] \\
\text{INFO } \langle \boxed{3}info \rangle \end{array} \right] \\
\text{NON-HD-DTR } \langle \dots, \boxed{4} \left[\begin{array}{l}
p\text{-}wrd \\
\text{TONE } \langle \boxed{2}tone \rangle \\
\text{INFO } \langle \boxed{3}info \rangle \end{array} \right] \dots \rangle \\
\text{DOM } \langle \dots \boxed{1} \dots \boxed{4} \dots \rangle \\
\text{INFO } \left\langle \begin{array}{l} \boxed{3}info \\ \text{I-DOM } \langle \boxed{1} \oplus \boxed{4} \rangle \end{array} \right\rangle \end{array} \right] \vee \\
\left[\begin{array}{l}
\text{HD-DTR } \boxed{1} \left[\text{INFO } \langle \boxed{2}info \rangle \right] \\
\text{NON-HD-DTR } \langle \dots, \boxed{3} \left[\text{INFO } \langle \boxed{4}info \rangle \right], \dots \rangle \\
\text{DOM } \langle \dots \boxed{1} \dots \boxed{3} \dots \rangle \\
\text{INFO } \left\langle \begin{array}{l} \boxed{2}info \\ \text{I-DOM } \boxed{1} \end{array} \right\rangle, \left\langle \begin{array}{l} \boxed{4}info \\ \text{I-DOM } \boxed{3} \end{array} \right\rangle \\
\boxed{2} \neq \boxed{4} \end{array} \right]
\end{array}$$

Figure 5: Information Status Projection Constraint (ISPC)

original formulation of mkMtr, defines metrical trees as consisting of a group of leaners attached to a final prosodic word with the latter being the DTE. The leaner group has the value of its TONE feature structure-shared with that of the prosodic word of the leaner group. (14d-i) is the first of the two definitions for $mkMtr^{full}$. It requires that all the members of its argument list share the same tone value, which means they should all belong to the same intonational phrase (IP). In that case, it makes a metrical tree in the usual manner and structure-shares its tone value with that of the daughters. (14d-ii) places metrical objects in the same prosodic constituent just in case those objects bear the same tone specification. Then it makes a metrical tree out of the result with the remainder of the list of prosodic objects passed to it. Notice that $mkMtr_{LA}$ has been omitted because we are no longer making prosodic structures based on syntactic ones.

3.4 Scope of *Theme/Rheme* Status

The issue of the scope of *theme* and *rheme*, also known as “the projection problem” is approached in this subsection. We define this concept in the form of the *Information Status Projection Constraint (ISPC)* as a type constraint on *hd-cx*. ISPC is formalised in Figure 5.

According to ISPC the arguments of the head daughter in a headed construction

by default inherit the information status of that predicate through structure sharing. When an argument is overtly marked for *theme* or *rheme*, it will not inherit the information status (and tone) of the head. Thus in (9c), repeated here as (18), for example, *begin* inherits theme status from *want*, and *write* and *play* inherit *rheme* from *try*.

$$(18) \quad [(I \text{ want}) (to \text{ begin})]_{\theta} [(to \text{ try}) [(to \text{ write}) (a \text{ play})]]_{\rho}$$

$$\quad \quad \quad L+H^* LH\% \quad \quad \quad H^*LL\%$$

Multiple theme and rheme markings are also possible and they can be distinguished by the fact that multiple themes/rhemes are listed separately in the INFO feature. We do not consider the projection problem in non-head constructions in this work. Since we assume that the rule schemata allow for the union of the domain objects of their daughters as well as the lists of informational objects, we always have access to the information status of any given prosodic word.

3.5 Accounting for the Data

Let us now go over the derivation of the examples in (13). These derivations are straightforward. In the following two derivations, we use the AVM notation for better exposition. Subsequent examples are represented in Klein's more succinct notation.

Figure 6 shows the derivation of (13a) in terms of its syntactic and information structures. Initially, *milk* is not marked for information status. It inherits the *rheme* status because of ISPC due to being an argument of the verb. This is shown in the VP construction. The subject does not fall under the scope of *rheme* because it is already marked as *theme*. The application of the ITAC throughout the derivation provides the list of domain objects shown in (19) for the resulting S construction.

$$(19) \quad \left[\text{DOM} \left\langle \begin{array}{l} \boxed{1} \text{ PH} \left[\begin{array}{l} \textit{Jane} \\ \text{TONE} \langle [\boxed{4} \textit{fr}] \rangle \end{array} \right], \boxed{2} \text{ PH} \left[\begin{array}{l} \textit{drank} \\ \text{TONE} \langle [\boxed{5} \textit{fall}] \rangle \end{array} \right], \\ \boxed{3} \text{ PH} \left[\begin{array}{l} \textit{milk} \\ \text{TONE} \langle [\boxed{5} \textit{fall}] \rangle \end{array} \right] \end{array} \right\rangle \right]$$

The application of mkMtr to the list of domain objects shown in (19) is represented in (20). The second example, (13b) is derived analogously.

$$(20) \quad \text{mkMtr} \left(\left\langle \boxed{1} \left[\begin{array}{l} \textit{Jane} \\ \text{TONE} \langle [\boxed{4} \textit{fr}] \rangle \end{array} \right], \boxed{2} \left[\begin{array}{l} \textit{drank} \\ \text{TONE} \langle [\boxed{5} \textit{fall}] \rangle \end{array} \right], \boxed{3} \left[\begin{array}{l} \textit{milk} \\ \text{TONE} \langle [\boxed{5} \textit{fall}] \rangle \end{array} \right] \right\rangle \right) =$$

$$\text{mkMtr}^{full} \left(\text{mkAllLtrs} \left(\langle \boxed{1}, \boxed{2}, \boxed{3} \rangle \right) \right) = \text{mkMtr}^{full} \left(\langle \boxed{1}, \boxed{2}, \boxed{3} \rangle \right) =$$

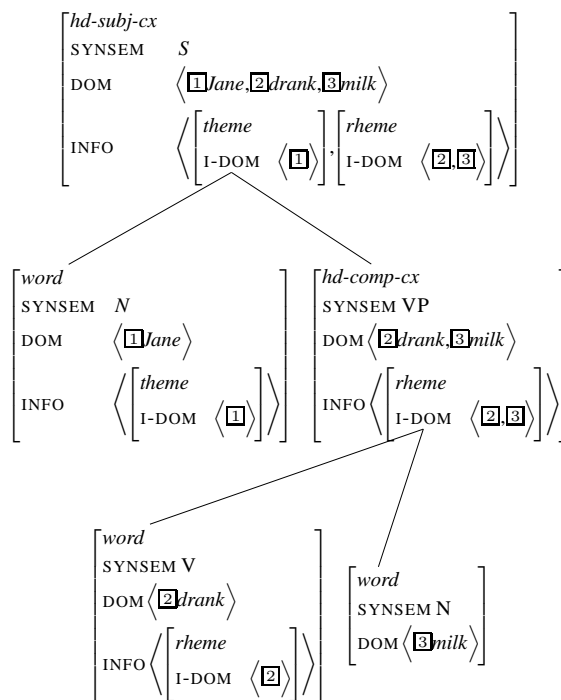

Figure 6: Syntactic/information-structural derivation of (13a)

$$\begin{aligned}
(22) \quad & \text{mkMtr} \left(\boxed{\langle I, \text{want}, \text{to}, \text{begin}, \text{to}, \text{try}, \text{to}, \text{write}, \text{a}, \text{play} \rangle} \right) = \\
& \text{mkMtr}^{full} \left(\text{mkAllLnr}(\boxed{\langle \rangle}) = \right. \\
& \left. \text{mkMtr}^{full} \left(\langle \langle (I \text{ want}), (to \text{ begin}), (to \text{ try}), (to \text{ write}), (a \text{ play}) \rangle \rangle \right) = \right. \\
& \left. \left[\left[(I \text{ want}) (to \text{ begin}) \right]^{rfr} \left[(to \text{ try}) (to \text{ write}) (a \text{ play}) \right]^{fall} \right] \right. \\
(23) \quad & \left. \left[(I \text{ want}) (to \text{ begin}) (to \text{ try}) (to \text{ write}) (a \text{ play}) \right] \right.
\end{aligned}$$

Notice that because the lexical items are unmarked in (21e) with respect to their information status, the prosodic structure that emerges is flat as shown in (23). This is an example where we see that what is generally known as prosodic flattening follows naturally from this account and no special theoretical devices are required to derive that structure from a highly structured syntactic tree.

The case of (9a) is somewhat different from the others. In this example, the pronoun *I*, a leaner, forms its own prosodic phrase bearing the L+H* LH% intonation that corresponds to theme. According to our model, however, the feature TONE is not appropriate to *lnr* because leaners by definition need a prosodic word to attach to. This can be solved by introducing a lexical rule that type-shifts leaners when their INFO feature is marked. This is formulated as (24) below.

$$(24) \quad \textbf{lnr Type-Shifting Rule} \\
\left[\begin{array}{ll} \text{PHON} & \textit{lnr} \\ \text{INFO} & \textit{marked-info} \end{array} \right] \Rightarrow \left[\text{PHON} \quad \textit{p-wrd} \right]$$

Let us now discuss example (7) repeated below as (25).

$$(25) \quad *[\text{Three mathematicians}] [\text{in ten prefer margarine}]$$

In Klein's model, this constituency simply does not arise because of PIH. In this model, we do not get the unacceptable constituency in (25) either because the informational status of one argument does not affect the other(s); i.e. if *prefer* is marked as theme and *margarine* as rheme, we still get the correct prosodic structure because the subject, *three mathematicians in ten*, inherits the theme status from *prefer*. However, one can think of a very implausible case that could give rise to (25) in our information-based analysis, and that is when *mathematicians* alone is marked as theme and *in ten* and *prefer* are marked as multiple rhemes. This information structure may not be felicitous in any context, but if it ever is, (25) will still be unacceptable because two different rhemes in (25) occur in the same IP. The correct prosodic structure that complies with the new definition of mkMtr is (26).

(26) [[Three mathematicians]_θ (in ten)_ρ [prefer margarine]_ρ]

The above example brings us to our next set of data presented earlier in (8) repeated below as (27).

- (27) a. [Jane gave the book to Mary]
 b. [Jane] [gave the book to Mary]
 c. [Jane gave the book] [to Mary]
 d. [Jane gave] [the book] [to Mary]
 e. * [Jane] [gave] [the book to Mary]
 f. * [Jane gave] [the book to Mary]
 g. [Jane] [gave the book] [to Mary]
 h. [Jane] [gave] [the book] [to Mary]

According to our analysis, (27a) is considered the unmarked case. In (27b), *Jane* has been marked as theme and *gave* as rheme, which passes down this status to its arguments *book* and *Mary*. Furthermore, in (27c), *gave* has been marked as theme and *Mary* as rheme. As mentioned earlier, Selkirk (1984) attributes the ungrammaticality of (27e, f) to the violation of the Sense Unit Condition since *the book* and *to Mary* do not form a sense unit. We achieve the same effect in this approach by ISPC and assuming that no more than one information unit (i.e. theme/rheme) can be present in one IP. In other words, each intonation phrase corresponds to only one information unit. This is in line with our version of PIH. Such an analysis entails that in (27d, g, h), there are multiple themes or rhemes and those multiple themes or rhemes are reflected as separate IPs in phonology. (27e, f) are ungrammatical because *the book* and *to Mary* have different informational markings, i.e. theme/rheme, rheme₁/rheme₂ or the like. This condition also prevents (25) because the only way that *in ten* can be separated from *three mathematicians* is to have a different informational marking, which by ISPC could not be structure-shared with the informational marking of *prefer margarine*. Not only ISPC ensures that each information unit reflects the right intonation in phonology; together with the mkMtr function, they also provide an implementations of Selkirk's (1984) *Sense Unit Condition* without resorting to another level of representation and unnecessary complication of the theory.

As an example, let us look at the sentences in (27) again. (27d, g, h) have multiple themes or rhemes. The indexed *info* and its corresponding *tone* value ensure that multiple themes or rhemes are not mistakenly grouped together. (27c) receives the following prosodic and information structure if we assume that *give* and *book* are marked as multiple themes.

(28) [[Jane gave]_{θ₁}^{rfr1} (the book)_{θ₂}^{rfr2} (to Mary)_{ρ₁}^{fall1}]

Examples (27e, f) are automatically rejected because the two arguments of *give* are sisters of one another; therefore, they cannot bear the same information status by ISPC, and thus, cannot be in the same IP.

Another interesting consequence of the information-based account of prosody in a tripartite grammar architecture is the fact that an ill-formed prosodic structure like (29) never arises because of the way mkMtr has been defined and this relieves us from positing Klein’s *Lexical Head Association Constraint*, which according to him is a partial implementation of Selkirk’s end-based mapping.

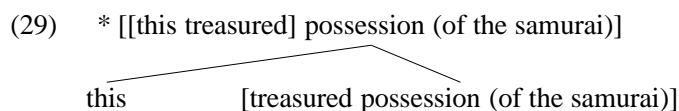

4 Concluding Remarks

This paper started off with Klein’s (2000) analysis of prosodic constituency in HPSG and extended it to account for some prosodic variation phenomena that are dependent upon the information structure of the sentence. Because a constraint-based approach to prosodic phenomena is employed here, we can capture some interesting linguistic generalities without recourse to *ad hoc* operational rules. In addition, the modular design of the theory allows for better readability and maintainability. The departure from a syntactocentric theory towards a tripartite one in terms of Jackendoff (2002) proved to be a promising approach as it captured a lot of the phenomena previously discussed in the literature in much simpler terms.

The most natural course of action to take from this point is to map all the other intonation forms with information structure in this approach and see what effects they have on the grammar overall. We should also try to find more constraints that syntax, semantics, or pragmatics impose on prosodic structure and even word order. For example, an account of heavy-NP shift and other similar phenomena in this model seems promising.

References

- Asudeh, A. and L. H. Mikkelsen (2000). Incorporation in Danish: Implications for interfaces. See Cann et al. (2000), pp. 1–15.
- Bing, J. (1970). *Aspects of English Prosody*. Ph. D. thesis, University of Massachusetts.
- Bird, S. (1990). *Constraint-Based Phonology*. Ph.D. thesis, University of Edinburgh.
- Bird, S. (1995). *Computational Phonology: A Constraint-Based Approach*. Studies in Natural Language Processing. Cambridge: Cambridge.
- Bird, S. and E. Klein (1991). Phonological analysis in typed feature systems. *Computational Linguistics* 20(3), 455–491.

- Borsley, R. D. and A. Przepiórkowski (Eds.) (1999). *Slavic in Head-Driven Phrase Structure Grammar*. Studies in Constraint-Based Lexicalism. Stanford: CSLI.
- Butt, M. and T. H. King (1998). Interfacing phonology with LFG. In M. Butt and T. H. King (Eds.), *Proceedings of the LFG98 Conference*, Stanford, CA. CSLI. <http://csli-publications.stanford.edu/LFG/3/butt-king/butt-king.html>.
- Cann, R., C. Grover, and P. Miller (Eds.) (2000). *Grammatical Interfaces in HPSG*. Studies in Constraint-Based Lexicalism. Stanford: CSLI.
- Cooper, W. and J. Paccia-Cooper (1980). *Syntax and Speech*. Cambridge, Mass.: Harvard University Press.
- De Kuthy, K. (2002). The information structure of discontinuous NPs in German. In L. H. van Eynde, Frank and D. Beermann (Eds.), *Proceedings of the 8th International HPSG Conference*, Stanford, pp. 148–161. Norwegian University of Science and Technology: CSLI.
- Engdahl, E. and E. Vallduví (1994). *Information Packaging and Grammar Architecture: A Constraint-Based Approach*, Volume 1.3.B of DYANNA-2 Report, pp. 41–78. Amsterdam: ILLC.
- Höhle, T. N. (1999). An architecture for phonology. See Borsley and Przepiórkowski (Eds.) (1999), pp. 61–90.
- Jackendoff, R. (1997). *The Architecture of the Language Faculty*. Linguistic Inquiry: Monograph Twenty-Eight. Cambridge, Mass.: MIT Press.
- Jackendoff, R. (2002). *Foundations of language: Brain, Meaning, Grammar, Evolution*. New York, NY: Oxford.
- Kahane, H. and R. Beym (1948). Syntactical juncture in colloquial Mexican Spanish. *Language* 24, 388–396.
- Kathol, A. (1995). *Linearization-Based German Syntax*. Ph.D. thesis, Ohio State University.
- Kathol, A. (2000). *Linear Syntax*. Oxford University Press.
- Klein, E. (2000). Prosodic constituency in HPSG. See Cann et al. (2000), pp. 169–200.
- Ladd, D. R. (1996). *Intonational Phonology*. Cambridge Studies in Linguistics. New York: Cambridge.
- Penn, G. (1999a). A generalized-domain-based approach to Serbo-Croatian second position clitic placement. In G. Bouma, E. Hinrichs, G. Kruijff, and R. Oehrle (Eds.), *Constraints and Resources in Natural Language Syntax and Semantics*, Studies in Constraint-Based Lexicalism, pp. 119–136. Stanford: CSLI.

- Penn, G. (1999b). Linearization and WH-extraction in HPSG: Evidence from Serbo-Croatian. See Borsley and Przepiórkowski (Eds.) (1999), pp. 149–182.
- Penn, G. and M. Haji-Abdolhosseini (2003). Topological parsing. In *Proceedings of the 10th Conference of the European Chapter of the Association for Computational Linguistics*, pp. 283–290.
- Pierrehumbert, J. (1980). *The phonology and phonetics of English intonation*. Ph.D. thesis, MIT. published 1988 by IULC.
- Pollard, C. and I. Sag (1994). *Head-Driven Phrase Structure Grammar*. Studies in Contemporary Linguistics. Chicago: CSLI.
- Prevost, S. (1995). *A semantics of contrast and information structure specifying intonation in spoken language generation*. Ph.D. thesis, University of Pennsylvania.
- Prevost, S. and M. Steedman (1994). Specifying intonation from context for speech synthesis. *Speech Communication* 15, 139–153.
- Pulgram, E. (1970). *Syllable, Word, Nexus, Cursus*. The Hague: Mouton.
- Reape, M. (1994). Domain union and word order variation in German. In J. Nerbonne, K. Netter, and C. J. Pollard (Eds.), *German in Head-Driven Phrase Structure Grammar*, Number 46 in CSLI Lecture Notes, pp. 151–197. CSLI Publications.
- Selkirk, E. O. (1981). On prosodic structure and its relation to syntactic structure. In T. Fretheim (Ed.), *Nordic Prosody II: Papers from a Symposium*, pp. 111–140. Trondheim: Tapir.
- Selkirk, E. O. (1984). *Phonology and Syntax: The Relation between Sound and Structure*. Cambridge, MA: MIT Press.
- Steedman, M. (1991). Structure and intonation. *Language* 25(2), 193–247.
- Steedman, M. (2000a). Information structure and syntax-phonology interface. *Linguistic Inquiry* 31(4), 649–689.
- Steedman, M. (2000b). *The syntactic process*. Cambridge, MA: MIT Press.
- Vallduví, E. and E. Engdahl (1996). The linguistic realization of information packaging. *Linguistics* 34, 459–519.
- Yoshimoto, K. (2000). A bistratal approach to the prosody-syntax interface in Japanese. See Cann et al. (2000), pp. 267–281.
- Zwicky, A. M. (1982). Stranded *to* and phonological phrasing. *Linguistics* 20, 3–57.

An HPSG analysis of the non-integrated *wh*-relative clauses in German

Anke Holler 

University of Heidelberg
TEMIS Deutschland

Proceedings of the 10th International Conference on
Head-Driven Phrase Structure Grammar

Michigan State University

Stefan Müller (Editor)

2003

Stanford, CA: CSLI Publications

pages 163–180

Holler, Anke. 2003. An HPSG analysis of the non-integrated *wh*-relative clauses in German. In Stefan Müller (ed.), *Proceedings of the 10th International Conference on Head-Driven Phrase Structure Grammar, Michigan State University*, 163–180. Stanford, CA: CSLI Publications. DOI: 10.21248/hpsg.2003.10. 

Abstract

In this article, the so-called *wh*-relative clause construction is investigated. The German *wh*-relative clauses are syntactically relevant as they show both, root clause and subordinate clause properties. They matter semantically because they are introduced by a *wh*-anaphor that has to be resolved by an appropriate abstract entity of the matrix clause. Additionally, the *wh*-relative clause construction is discourse-functionally peculiar since it evokes coherence. Besides these interesting empirical characteristics, *wh*-relatives raise important theoretical questions. It is argued that the standard HPSG theory has to be extended to account for non-restrictive relative clauses in general, and to cope with the particular properties of the *wh*-relative construction.

1 Introduction

This paper discusses a certain class of German relative clauses. They are called ‘*wh*-relatives’ since this class can easily be detected by an overt left-peripheral *wh*-relative expression. A typical example of this class is given in (1):

- (1) Anna hat die Schachpartie gewonnen, was Peter ärgerte.
Anna has the game of chess won which Peter annoyed
‘Anna won the game of chess, which annoyed Peter.’

The investigation of the *wh*-relatives is worthwhile for two reasons:

Firstly, although the *wh*-relatives are mentioned in almost every grammar book of German, to date their grammatical properties have not been studied comprehensively, the only exception being Brandt (1990). Brandt focusses on the pragmatic aspects of the *wh*-relative construction and therefore does not provide a formalized syntactic and semantic analysis of *wh*-relatives.

Secondly, the existence of the *wh*-relative construction makes it necessary to extend the HPSG theory as given by Pollard und Sag (1994).

The paper is organized as follows:

In the first part, the *wh*-relatives will be described empirically. By characterizing their syntactic behaviour, it is investigated how *wh*-relatives are linked to the complex sentence structure. Then, the semantic and discourse-functional properties of the *wh*-relative construction will be examined.

In the second part, the *wh*-relatives are interpreted within the HPSG framework. An analysis will be developed that allows both, to cope with non-restrictive relative clauses in general, and to give an adequate formalization of the *wh*-relative construction.

2 Empirical facts

The point of departure is the hypothesis stated in (2):

- (2) A *wh*-relative is a relative clause with the following properties:
- A *wh*-relative is a non-restrictive clause introduced by an anaphoric *wh*-expression.
 - Syntactically, it is dependent on a matrix clause without being embedded into it.
 - Semantically, it is related to various kinds of abstract entities.
 - Pragmatically, the *wh*-relative construction establishes a symmetric discourse relation.

In the following, this hypothesis will be tested.

2.1 Syntactic properties

2.1.1 Left periphery

One can easily recognize a *wh*-relative by its left periphery. Three kinds of expressions which may act as a complement or an adjunct of the relative clause's predicate can be observed on the left of a *wh*-relative:

(i) The underspecified pronoun *was* ('*which*') as illustrated in (3) occurs at the left of a *wh*-relative. *Was* represents either a verbal phrase or a nominal phrase. In the latter case *was* is not specified with respect to person, number and gender, but depending on the selection properties of the respective predicate it is case marked as nominative or accusative.

- (3) a. Max kann Orgel spielen, *was*_{VP} Anna auch kann.
Max can organ play which Anna too can
 'Max can play the organ, which Anna can, too.'
- b. Max spielt Orgel, *was*_{NP[NOM]} gut klingt.
Max plays organ which good sounds
 'Max is playing the organ, which sounds good.'
- c. Max spielt Orgel, *was*_{NP[ACC]} Anna überrascht.
Max plays organ which Anna surprises
 'Max is playing the organ, which surprises Anna.'

(ii) *wh*-Adverbs such as *weswegen* ('*why*') and *wofür* ('*for which*') as illustrated in (4) can introduce a *wh*-relative. These adverbs preserve their modal, temporal or causal meaning if they occur in a *wh*-relative.

- (4) a. Otto hat sich sein Bein gebrochen, *weswegen* er jetzt im Krankenhaus ist.
Otto has REFL his leg broken that's why he now in hospital is
 'Otto broke his leg, and that's why he is in hospital now.'

- b. Otto schenkt Emma Schokolade, wofür sie ihm dankt.
Otto gives Emma chocolate for which she him thanks
 ‘Otto gives Emma chocolate for which she thanks him.’

(iii) Complex expressions including a *wh*-element and an abstract noun can be found at the left of a *wh*-relative as exemplified in (5). In this case, the meaning of the abstract noun has to be compatible with the meaning of the matrix clause’s predicate.

- (5) Max bat Maria, einen Brief einzuwerfen, welcher Bitte sie nachkam.
Max asked Maria a letter to mail which request she granted
 ‘Max asked Maria to mail a letter, and she granted this request.’

Note that the *wh*-expressions presented here are all anaphoric since their meaning depends on a preceding item. I will come back to this issue in section 2.2.

2.1.2 Variants of the *wh*-relative construction

Depending on the syntactic status of the *wh*-expression three *wh*-relative construction variants can be distinguished, which are dubbed variant A, variant B and variant C.

In the construction variants A and B, the left-peripheral *wh*-expression is selected by the relative clause’s predicate. In the construction variant C, the *wh*-expression modifies the respective predicate.

The variants A and B differ in the particular selection properties of the predicate of the *wh*-relative clause. The sentence given in (1) repeated here as (6) is an example for the construction variant A.

- (6) Anna hat die Schachpartie gewonnen, was Peter ärgerte.
Anna has the game of chess won which Peter annoyed
 ‘Anna won the game of chess, which annoyed Peter.’

Predicates that occur in a *wh*-relative of this variant are subcategorized for a finite sentential or an infinitival complement of the ‘2. Status’ (Bech, 1957) that can alternatively be realized as a nominal or prepositional phrase. For this reason a verb like *sich weigern* (‘to refuse to do something’) cannot occur in a *wh*-relative as can be seen in (7). Although *sich weigern* allows an infinitival complement (cf. (7b)), it cannot take a nominal complement (cf. (7c)).

- (7) a. *Peter soll seinen Freund verraten, was er sich weigerte.
Peter was to his friend betray which he REFL refused
 ‘Peter was to betray his friend, but he refused it.’
 b. Peter weigerte sich, seinen Freund zu verraten.
Peter refused REFL his friend to betray
 ‘Peter refused to betray his friend.’

- c. * Peter weigerte sich den Verrat seines Freundes.
Peter refused REFL the betrayal his friend

Examples for the construction variant B are given in (8). This construction variant is similar to the so-called VP-ellipses as *was* ('which') realizes a VP complement. The class of verbs occurring in these constructions is restricted to auxiliary verbs such as *haben* ('to have'), *sein* ('to be') and *werden* ('will') and to auxiliary modal verbs in root interpretation. Hence, example (9) containing an epistemic modal is ungrammatical.

- (8) a. In München hat es geschneit, was es in Stuttgart auch hat.
In Munich has EXPL snowed which EXPL in Stuttgart as well has
 'It snowed in Munich and in Stuttgart as well.'
- b. Otto muss nach Frankreich fahren, was Max jetzt auch soll.
Otto must to France go which Max now too should
 'Otto must go to France, which Max should do now, too.'
- (9) * Peter muss krank gewesen sein, was Otto auch muss.
Peter must sick been has which Otto too must.

As mentioned before, construction variant C covers all clauses introduced by a *wh*-phrase modifying the *wh*-relative's predicate. This is exemplified in (10):

- (10) Otto ist krank, weshalb er zu Hause bleiben muss.
Otto is sick that's why he at home stay must
 'Otto is sick, and that's why he has to stay at home.'

Looking at the examples given so far, it is obvious that *wh*-relatives can be considered relative clauses. First, they are attached to a preceding clause. Second, they are introduced by a relative constituent that is grammatically dependent on the predicate of the *wh*-relative and that is linked to an entity of the matrix clause. The next question to be discussed is whether *wh*-relatives are in fact non-restrictive clauses.

2.1.3 Root clause properties

The strongest evidence for the claim that *wh*-relatives belong to the class of non-restrictive clauses comes from the observation that they behave like typical root clauses. This is shown by the following phenomena symptomatic of root clauses.

As indicated by (11), a *wh*-relative clause can easily be transformed into a main clause.

- (11) Anna hat die Schachpartie gewonnen. Das ärgerte Peter.
Anna won the game of chess. This annoyed Peter.

Also, epistemic expressions, performative indicators, modal particles, etc. can be found in *wh*-relatives, cf. (12a) to (12c).

- (12) a. Anna hat die Schachpartie gewonnen, was Peter sicher ärgerte.
Anna has the game of chess won which Peter certainly annoyed
 ‘Anna won the game of chess, which must have annoyed Peter.’
- b. Die Firma handelt mit Waffen, weshalb ich hiermit
the company deals with weapons that’s why I hereby
 kündige.
hand in my notice
 ‘The company deals with weapons, and that’s why I hereby hand in my notice.’
- c. Max hat den Preis bekommen, was wohl jeden überraschte.
Max has the prize won which well everyone surprised
 ‘Max won the prize, which was probably surprising for everyone.’

Furthermore, it is impossible to form a Yes/No-question integrating the whole *wh*-relative construction. This is indicated by (13).

- (13) * Hat Anna die Schachpartie gewonnen, was Peter ärgerte?
has Anna the game of chess won which Peter annoyed

Last, the root clause character of *wh*-relatives is confirmed by examples like (14). A quantifier occurring in the matrix clause cannot bind a variable within the *wh*-relative:

- (14) a. * Niemand_i gewann das Schachspiel, was ihn_i maßlos ärgerte.
nobody_i won the game of chess which him_i extremely annoyed
- b. * Jeder_i hat sich das Bein gebrochen, weswegen er_i jetzt im
everyone_i has REFL the leg broken that’s why he_i now in
 Krankenhaus ist.
hospital is

2.1.4 Independent focus domain

The observation that a *wh*-relative establishes an independent focus domain within the *wh*-relative construction provides additional evidence for the non-restrictiveness of a *wh*-relative clause.

The standard test for focus assumes that the focus structure of a given declarative utterance can be identified by reconstructing a question that would license the utterance as a coherent answer. The focus corresponds to the interrogative constituent in that question. Based on these test conditions, (15) suggests that the focus does not project out of the *wh*-relative since (15a) is not a coherent answer to the question ‘What happened?’.¹

¹In the example, focus is marked by a syntactic focus feature that projects from the pitch-accented focus exponent written in capital letters.

(15) *Was ist passiert?*

- a. # [Anna gewann die Schachpartie, was Peter von seiner
Anna won the game of chess which Peter from his
SCHWEster erwartet hat.]_F
sister expected has
'Anna won the game of chess, which Peter expected from his sister.'

The independent focus domain of a *wh*-relative is also supported by (16), which demonstrates that the focus sensitive particle *nur* ('only') occurring in the matrix clause does not scope over the *wh*-relative:

- (16) ? Anna gewann nur die Schachpartie, was Peter von seiner Schwester
Anna won only the game of chess which Peter from his sister
erwartet hat.
expected has
'Anna only won the game of chess, which Peter expected from his sister.'

2.1.5 Assertion versus presupposition

A third argument for the non-restrictiveness of *wh*-relative clauses is provided by data like (17), which show that a *wh*-relative is asserted and not presupposed.

- (17) Peter bedauerte, dass er die GRÜNEN gewählt hatte, was seine Frau
Peter regretted that he the Green Party elected had which his wife
wiederum gut verstand.
in turn well understood
'Peter regretted to have elected the Green Party, which his wife well understood'

Against the background of the presented evidence, it is convincing that *wh*-relatives are non-restrictive clauses. Consequently, the left-peripheral *wh*-expression has to be interpreted anaphorically.

In the next section it will be investigated how *wh*-relatives are related to their matrix clause.

2.1.6 Complex sentence structure

In the literature, one often finds the statement that a *wh*-relative is sentence-related. Based on the assumption that the matrix clause of the *wh*-relative construction can be transformed into a component part of the relative clause², it is claimed that a *wh*-relative and its matrix clause establish an inverse dependency relation. Assuming this inverse relationship, the *wh*-expression is taken as a place holder or a variable representing the whole matrix clause, cf. Helbig (1980) and Steube (1991).

Contrary to this assumption, Brandt (1990) argued that examples like (18) show that *wh*-relatives are related to sub-sentential syntactic units.

²In the German grammar tradition, the term 'Satzglied' is used here.

- (18) Er kann schon schwimmen, was sie noch nicht kann.
He is able to already swim which she yet not is able to
 ‘He is able to swim, which she isn’t, yet.’

However, the phenomenon she describes cannot solely be attributed to syntax. As suggested by example (19), the data should rather be explained in semantic terms.

- (19) a. Die Geologen erforschen einen neuen Vulkan, was sehr interessant
the geologists explore a new volcano which very interesting
 ist.
is
 ‘The geologists explore a new volcano, which is very interesting.’
 b. “Dass sie einen neuen Vulkan erforschen, ist sehr interessant.”
 ‘That the geologists explore a new volcano is very interesting.’
 c. “Einen neuen Vulkan zu erforschen ist sehr interessant.”
 ‘To explore a new volcano is very interesting.’
 d. “Das Erforschen eines neuen Vulkans ist sehr interessant.”
 ‘The exploring of a new volcano is very interesting.’

(19a) has three readings, (19b) to (19d), depending on the interpretation of the *wh*-anaphor. *Was* (*‘which’*) can be resolved (i) by the proposition denoted by the matrix clause, cf. reading (19b), or (ii) by an eventuality such as the process of exploring, cf. reading (19c), or (iii) by the exploration-event, cf. reading (19d). Because the string of the matrix clause standing alone is not ambiguous at all, examples like (19) prove that the crucial grammatical relation between a *wh*-relative and its matrix clause is a semantic one. This view is also supported by the data given in (20).

- (20) a. Maria will sich ihre Haare kämmen, was Hans auch will.
Maria wants REFL her hair comb which Hans too wants
 ‘Maria wants to comb her hair, which Hans wants to do, too.’
 b. “Hans_i will sich_i seine Haare kämmen.”
 ‘Hans wants to comb his hair.’

(20a) has a reading where the reflexive pronoun *sich* (*‘herself’*) gets a sloppy interpretation as expressed by (20b). This reading could not be explained by a syntactic operation that just transforms parts of the matrix clause into a component part of the *wh*-relative.

The semantic nature of the reference relation is further substantiated by (21). The indefinite NP in the matrix clause is interpreted generically, whereas it gets a specific interpretation within the *wh*-relative. Thus, the semantic information of the matrix clause is accessible from the *wh*-relative clause.

- (21) Maria wollte keinen Linguisten heiraten, was sie dann aber doch
Maria wanted no linguist marry which she then PART PART
 getan hat.
done has

‘Maria didn’t want to marry a linguist, which she did in the end.’

Consequently, one must strictly distinguish between the syntactic and the semantic relations established within the *wh*-relative construction: Whereas the semantic relation is triggered by the left-peripheral *wh*-anaphor, the syntactic relation affects the way of how the *wh*-relative is attached to its preceding clause.

With regard to the syntactic relation, it becomes apparent that a *wh*-relative is not licensed by the predicate of the matrix clause.³ The *wh*-relative neither saturates one of the argument positions of the matrix predicate nor modifies the matrix predicate. Nevertheless, it is obvious that *wh*-relatives are depending clauses.

Reis (1997) argued that some clauses in German may be dependent on a matrix clause although they are not licensed by the matrix predicate. In other words, these clauses are linked to the complex sentence structure without being part of the verbal projection of the matrix clause. Reis (1997) calls these clauses ‘non-integrated’. She lists four main properties of this clausal class. Firstly, non-integrated clauses are prosodically and pragmatically independent from the matrix clause which is indicated by an independent focus domain. Secondly, variable binding is not allowed from the matrix clause into the non-integrated clause. Thirdly, a non-integrated clause is syntactically dispensable, and fourthly, a non-integrated clause always stands at the end of a complex sentence.

Taking these criteria into account, *wh*-relatives can be classified as non-integrated clauses. As shown in section 2.1.4, they establish an independent focus domain; they are impermeable for variable binding from outside; and they are syntactically dispensable as they can be transformed into a main clause. Thus, the first three of Reis’s criteria clearly apply to *wh*-relatives. In addition, the fourth criterion is met as well. (22) and (23) illustrate that a *wh*-relative always comes last because it has to follow an extraposed complement clause (22) or relative clause (23).

- (22) a. Es fiel Maria nicht auf, dass sie sich verrechnet hatte,
EXPL realized Maria not PART that she REFL mistaken had
weswegen sie sich jetzt ärgert.
that’s why she REFL now annoyed
‘Maria didn’t realize that she made a mistake, and that’s why she is
annoyed now.’
- b. * Es fiel Maria nicht auf, weswegen sie sich jetzt ärgerte,
EXPL realized Maria not PART that’s why she REFL now annoyed
dass sie sich verrechnet hatte.
that she REFL mistaken had
- (23) a. Anna hat einen Ring verloren, der sehr wertvoll war, weshalb sie
Anna has a ring lost that very valuable was that’s why she
sich jetzt maßlos ärgerte.
REFL now extremely annoyed

³This can be shown by applying the traditional constituent tests, which clearly reveal that a *wh*-relative is neither attached to a verb nor a verbal phrase of the matrix clause, cf. Holler (2001).

‘Anna lost a ring that was very valuable, and that’s why she was annoyed now.’

- b. * Anna hat einen Ring verloren, weshalb sie sich jetzt maßlos
Anna has a ring lost that’s why she REFL now extremely
ärgerte, der sehr wertvoll war.
annoyed that very valuable was

The above listed syntactic facts can be accounted for by analysing the *wh*-relative as a syntactic sister of the sentential projection introduced by the matrix clause. Before discussing how this can be formalized within the HPSG theory, the semantic and discourse functional properties of *wh*-relatives will be described in more detail.

2.2 Semantic properties

In the literature going back to philologic grammar tradition, it is generally claimed that a *wh*-relative must refer to a fact. Although a reference to facts and propositions is indeed possible as (24) shows,

- (24) Grass sagte die Lesung ab, was bedauerlich ist.
Grass cancelled the reading PART which regrettable is
‘Grass cancelled the reading, which is regrettable.’

the afore mentioned example in (19) and the ones in (25) indicate that a *wh*-relative refers to non-propositional entities as well.

- (25) a. Nachbars Hund bellte, was sogar Anna hörte, obwohl sie zwei
neighbor’s dog barked which even Anna heard although she two
Straßen weiter wohnt.
blocks away lives
‘The neighbor’s dog barked, which even Anna heard although she lives two blocks away.’
- b. Max rasierte sich, was eine halbe Stunde dauerte.
Max shaved REFL which an half hour took
‘Max shaved, which took him half an hour.’
- c. Anna gewinnt immer die Schachpartie, was Peter ärgert.
Anna wins always the game of chess which Peter annoys
‘Anna always wins the game of chess, which annoys Peter.’
- d. Karl hat den K2 bestiegen, was Otto auch gelungen ist.
Karl has the K2 climbed which Otto as well achieved is
‘Karl climbed the K2, which Otto achieved as well.’

In (25a), the predicate of the *wh*-relative consists of a recognition verb, namely *hören* (‘to hear’), and the *wh*-anaphor *was* (‘which’) refers to the event of a dog barking. Similarly, the *wh*-anaphor in (25b) restricted by the verb *dauern* (‘to

take’) refers to an event. (25c) and (25d) show that even eventualities are possible antecedents of a *wh*-relative. (25c) means that Peter is annoyed *every time* Anna wins the game of chess. The verb *gelingen* (‘to achieve’) in (25d) generally selects an eventuality if the respective argument is verbal. If *was* (‘which’) of example (25d) referred to a fact or an event, Otto would have given Karl a piggyback, which is certainly not the meaning of (25d). Even if one restricts the antecedents of the *wh*-relative to propositional ones, *wh*-relatives are not only fact-related. In (26) for instance the *wh*-relative is related to an attitude and not to a fact.

- (26) Fred glaubte, dass Grass die Lesung abgesagt hatte, was Anna nicht
Fred believed that Grass the reading cancelled had which Anna not
gedacht hätte.
expect had

‘Fred believed that Grass cancelled the reading, which Anna didn’t expect.’

Finally, the examples in (27) show that so-called projective propositions, such as interrogative clauses or the infinitival complements of modal verbs, can be appropriate antecedents of a *wh*-relative.

- (27) a. Maria will wissen, welche Prüfungen sie ablegen muss, was ihr
Maria wonders which exams she take must which her
aber niemand sagte.
PART *nobody told*

‘Maria wonders which exams she has to take, which nobody told her.’

- b. Karl wollte eine Maus halten, was seine Mutter ihm aber nicht
Karl wanted a mouse keep which his mother him PART not
erlaubte.
allowed

‘Karl wanted to keep a mouse, which his mother didn’t allow.’

Thus, we have to conclude that a fact is one possible antecedent of the *wh*-anaphor, but not the only possible antecedent. However, there are semantic restrictions that control the *wh*-relative construction. They limit the class of admissible *wh*-relative predicates and restrict the potential antecedents of the *wh*-anaphor. More precisely, the restriction given in (28) holds.

- (28) In a *wh*-relative construction, the semantic type of the *wh*-anaphor must correspond to the semantic type of at least one entity that can be abstracted from the matrix clause.

Restriction (28) accounts for the fact that (29a) but not (29b) is ungrammatical. The *wh*-anaphor is an argument of the verb *glauben* (‘to believe’) and therefore denotes a belief. An attitude, however, can be abstracted from the matrix clause only in (29b), but not in (29a).

- (29) a. * Fred heiratet Anna, was Max glaubt.
Fred married Anna which Max believes.

- b. Karl glaubt, dass Fred Anna heiratet, was Max auch glaubt.
Karl believes that Fred marries Anna which Max as well believes
 ‘Karl believes that Fred marries Anna, which Max believes, too.’

Within the approach of Asher (1993) it is possible to account for these empirical facts. Asher (1993) provides a semantics for abstract objects in the framework of DRT. Adapting Asher’s theory, the semantic relation between the *wh*-relative clause and the matrix clause is based on the anaphoric relation established between the *wh*-anaphor and a preceding object abstracted from the matrix clause. Thereby it is assumed that the *wh*-anaphor introduces into the representation a discourse referent that needs to be resolved. The semantic type of this discourse referent is restricted by the predicate of the *wh*-relative in case the *wh*-anaphor is an argument of the relative clause’s predicate. Otherwise it is propositional. A *wh*-construction is valid, if the matrix clause contains at least one abstract object that can resolve the *wh*-anaphor. A *wh*-construction is ambiguous, if the matrix clause contains several abstract objects that can act as an antecedent of the *wh*-anaphor.⁴

2.3 Discourse-functional properties

Let us finally turn to the discourse-functional properties of the *wh*-relative construction. A *wh*-relative construction is coherent as stated by Brandt (1990) and others. Brandt (1990) concluded that the matrix clause and the *wh*-relative bear the same communicative weight. She attributes this to the root clause character of the *wh*-relative. At a closer look, however, the communicative balance in fact arises from a symmetric discourse relation established between the matrix clause and the *wh*-relative. Following Asher’s discourse-structural theory, in a symmetric discourse relation at least the axioms of Continuation(α, β) have to be satisfied. Stated in Asher’s axiomatic system, (30) is a typical example for a CAUSE relation and (31) for a CONTRAST relation implemented in the *wh*-construction. Both relations continue the discourse and hence count as symmetric discourse relations.

- (30) a. Hans hatte einen Unfall, weswegen er im Bett liegen muss.
Hans had an accident that’s why he in bed lie must
 ‘Hans had an accident, and that’s why he has to stay in bed.’
 b. $\langle \alpha, \beta \rangle$ & **have_an_accident**(α) & **stay_in_bed**(β) > Cause(α, β)
- (31) a. Hans schreibt gerne Bücher, wohingegen Emma lieber tanzt.
Hans writes willingly books whereas Emma rather dance
 ‘Hans likes to write books, whereas Emma prefers dancing.’
 b. $\langle \alpha, \beta \rangle$ & **write_books**(α) & **dance**(β) > Contrast(α, β)

⁴For formal explication, see Holler (2001).

3 HPSG analysis

The last part of this paper concentrates on the HPSG analysis that is proposed to account for the empirical facts afore described. The *wh*-relative construction is of particular interest for the further development of the HPSG formalism. Standard HPSG theory has focussed on restrictive relative clauses, and hence, in this formalism a relative clause can only be attached to a preceding NP. It is shown in the next section how the standard theory can be extended to account for the special properties of the *wh*-relative construction.

The standard phrasestructural analysis of relative clauses in HPSG going back to Pollard und Sag (1994) is based on the assumption that a relative clause is a projection of a phonologically empty relativizer, cf. (32). This relativizer is subcategorized for two complements: a phrase containing a relative constituent expressed by a non-empty REL value and a finite verbal projection which is slashed by this relative phrase. The SLASH dependency is bound off by the relativizer. The relative clause is attached to a preceding noun by applying the HEAD-ADJUNCT Schema triggered by the attribute MOD. The relative clause is interpreted as a property, since the indices of the noun and the relative phrase are identified and their RESTRICTION values are unified.

$$(32) \left[\begin{array}{l} \text{LOC} \\ \text{CAT} \\ \text{CONT} \\ \text{NLOC} \mid \text{TO-BD} \mid \text{SLASH} \{ \boxed{4} \} \end{array} \left[\begin{array}{l} \text{HEAD} \left[\begin{array}{l} \textit{rtvzr} \\ \text{MOD } N' \mid \text{TO-BD} \mid \text{REL} \{ \boxed{1} \} : \left[\begin{array}{l} \text{INDEX } \boxed{1} \\ \text{RESTR } \boxed{3} \end{array} \right] \end{array} \right] \\ \text{SUBC} \langle \text{LOC } \boxed{4}, \text{INHER} \mid \text{REL} \{ \boxed{1} \} \rangle, \\ \text{S} \langle \textit{fin, unmarked}, \text{INHER} \mid \text{SLASH} \{ \boxed{4} \} : \boxed{5} \rangle \end{array} \right] \right] \right]$$

In section 2, it has been argued that (a) a *wh*-relative is a non-restrictive clause and (b) that its syntactic antecedent may differ from its semantic one. Whereas the syntactic relation is always unique as there is only one way *wh*-relative is attached to its matrix clause, the semantic relation depends on the potential antecedents resolving the left-peripheral *wh*-anaphor.

To cope with these properties, a second relativizer is defined besides the restrictive one that serves as the head of a non-restrictive *wh*-relative clause.⁵ Similar to the restrictive relativizer, the non-restrictive relativizer takes two complements: a relative phrase and a finite verbal projection slashed by this phrase. The non-restrictive relativizer also bears an non-empty MOD-attribute. In contrast to the restrictive relativizer, however, the value of the MOD attribute is specified as FP, as indicated by the schematic analysis in (33). The *wh*-relative thus syntactically

⁵The proposed analysis could easily be restated in a construction-based setting, cf. Sag (1997). I adhere to the phrasestructural account since i.a. it is not clear how the proliferation of types is prevented within a construction-based analysis. See Holler-Feldhaus (2001) for further arguments.

combines with a functionally complete and fully saturated sentential projection (i.e. FP) and not – as in the restrictive case – with a nominal phrase.

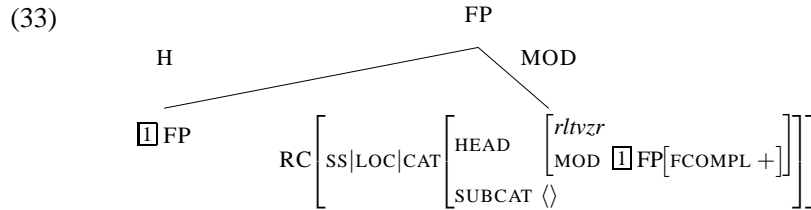

Leaving the details of German sentence structure aside, I assume binary branching and the concept of functional completeness (Netter, 1996). Functional completeness is expressed by a binary feature FCOMPL, which is specified as ‘plus’ if a sentential head (e.g. a complementizer) has been realized and as ‘minus’ otherwise. The analysis described so far accounts for the fact that a *wh*-relative syntactically relates to a sentence.

To cover the semantic relation between the *wh*-relative and its antecedent, we depart from the semantics used in standard HPSG. Following Frank und Reyle (1995), the structure of the CONTENT attribute as well as the Semantics Principle are changed, thereby integrating aspects of the framework of DRT into the semantic component of HPSG. As presented in (34), the CONTENT attribute is replaced by a complex feature structure, called DRS, which consists of three attributes, LS, SUBORD and CONDS. CONDS is a set of labelled DRS conditions, SUBORD contains information about the hierarchical structure of a DRS and LS defines distinguished labels within this hierarchy. Additionally, we assume that the DRS conditions instantiating the CONDS value are represented by a set of objects of type $p(\text{artial_})drs$.

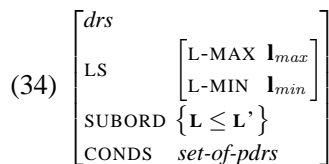

The Semantic Principle adapted from Frank und Reyle (1995) is depicted in (35). It controls the inheritance of the partial DRSEs defined in the CONDS attributes of the daughters to the CONDS value of the phrase. The semantic conditions are always inherited from both daughters and therefore project to the uppermost sentential level. Thus, the Semantics Principle applies to *head-comp*- and *head-adjunct-structures* in exactly the same way.

- (37) Anna gewann die Schachpartie, was Peter ärgerte.
Anna won the game of chess which annoyed Peter
 ‘Anna won the game of chess, which annoyed Peter.’

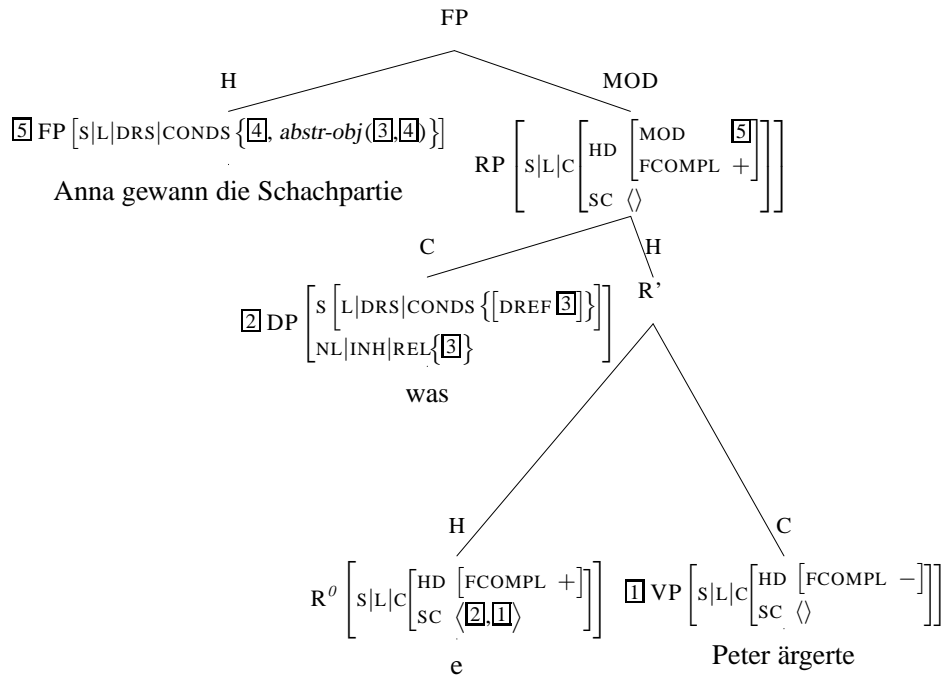

In this example, the *wh*-relative clause (= RP) is a projection of a functionally complete empty relativizer subcategorized for a fully saturated, but functionally incomplete VP (= $\boxed{1}$) and a relative phrase (= $\boxed{2}$). This relative clause is syntactically attached to a matrix clause that is functionally complete (= $\boxed{5}$ FP) by applying the HEAD-ADJUNCT Schema. The semantic relation between the matrix clause and the *wh*-relative is established by the anaphor *was*. According to the selection properties of the predicate *ärgern* ('to annoy'), *was* ('which') introduces a propositional discourse referent (= $\boxed{3}$) into the representation. This referent is resolved by an object (= *abstr-obj*($\boxed{3}$, $\boxed{4}$)) that is abstracted from the proposition introduced by the matrix clause (= $\boxed{4}$).

4 Conclusion

It was shown that *wh*-relatives behave like non-integrated clauses, and that they establish a class of German relative clauses of their own. It was argued that *wh*-relatives are related to a sentence only in syntactic respects. Semantically, however, *wh*-relatives can refer to entities of various semantic types (e.g. events, eventualities, propositions, projective propositions, attitudes, and facts.) Pragmatically, *wh*-relative constructions evoke coherence because of a symmetric discourse relation established between the matrix clause and the *wh*-relative. To account for these

facts an HPSG analysis has been developed that copes with non-restrictive relative clauses and allows an adequate description of the grammatical properties of the *wh*-relative construction. A *wh*-relative is analyzed as being attached to a sentential projection that is functionally complete. The left-peripheral *wh*-anaphor introduces a discourse referent into the semantic representation. The semantic type of this referent is restricted by the predicate of the *wh*-relative. The antecedent of the *wh*-anaphor is abstracted from the matrix clause whereby the semantic type of the object to be abstracted depends on the type of the discourse referent representing the *wh*-anaphor.

References

- Asher, N. (1993). *Reference to Abstract Objects in Discourse*. Studies in Linguistics and Philosophy 50. Dordrecht: Kluwer.
- Bech, G. (1957). *Studien über das deutsche verbum infinitum*. Kopenhagen: Munksgaard. unveränd. Auflage 1983, Tübingen: Niemeyer.
- Brandt, M. (1990). *Weiterführende Nebensätze*. Stockholm: Almquist & Wiksell International.
- Frank, A. und U. Reyle (1995). Principle Based Semantics for HPSG. In *Proceedings of the 7th Conference of the EACL, March 27-31, Dublin*, 9–16.
- Helbig, G. (1980). Was sind weiterführende Nebensätze? *Deutsch als Fremdsprache* 17, 13–23.
- Holler, A. (2001). *Empirische und theoretische Aspekte der Grammatik der weiterführenden Relativsätze*. Doktorarbeit, University of Tübingen.
- Holler-Feldhaus, A. (2001). An HPSG Analysis of German Wh-Interrogatives. In T. Kiss und D. Meurers (Hrsg.), *Constraint-Based Approaches to Germanic Syntax*, 67–100. Stanford University: CSLI Publications.
- Netter, K. (1996). *Functional Categories in an HPSG for German*. Doktorarbeit, Universität des Saarlandes, Saarbrücken. Published 1998 as Volume 3 of Saarbrücken Dissertations in Computational Linguistics and Language Technology.
- Pollard, C. und I. A. Sag (1994). *Head-Driven Phrase Structure Grammar*. Chicago: CSLI Publications and University of Chicago Press.
- Reis, M. (1997). Zum syntaktischen Status unselbständiger Verbzweit-Sätze. In C. Dürscheid, K. H. Ramers, und M. Schwarz (Hrsg.), *Syntax im Fokus. Festschrift für Heinz Vater*. Tübingen: Niemeyer.

Sag, I. A. (1997). English Relative Clause Constructions. *Journal of Linguistics* 33(2), 431–484.

Steube, A. (1991). w-Wörter als Konnektoren in den sog. weiterführenden Nebensätzen der deutschen Gegenwartssprache. In M. Reis und I. Rosengren (Hrsg.), *Fragesätze und Fragen*, 95–111. Niemeyer.

Topics First! In- and outside of Bulgarian *wh*-interrogatives

Florian Jaeger 

Stanford University

Proceedings of the 10th International Conference on
Head-Driven Phrase Structure Grammar

Michigan State University

Stefan Müller (Editor)

2003

Stanford, CA: CSLI Publications

pages 181–202

Jaeger, Florian. 2003. Topics First! In- and outside of Bulgarian *wh*-interrogatives. In Stefan Müller (ed.), *Proceedings of the 10th International Conference on Head-Driven Phrase Structure Grammar, Michigan State University*, 181–202. Stanford, CA: CSLI Publications. DOI: 10.21248/hpsg.2003.11. 

Abstract

In Jaeger (to appear) I have described clitic doubling in Bulgarian *wh*-interrogatives which constitutes a type of Superiority violation that cannot be accounted for by any existing analyses. By showing that clitic doubling of object *wh*-phrases marks topicality, I raised the hypothesis that many (or maybe all) so called Superiority effects in Bulgarian are due to topic-fronting of *wh*-phrases. Here, I provide further support for this hypothesis and show that there is also evidence for topic-fronting of non-object *wh*-phrases. Differences between colloquial and formal Bulgarian are restricted to how topical objects have to be realized at the site of the extraction (i.e. the VP), which also makes the account readily extendable to other multiple fronting languages. The complex ordering constraints on the left periphery are captured in a Linear Syntax approach (similar to but different from Kathol 2000).

1 Introduction

Superiority in multiple *wh*-interrogatives has been an ongoing topic in generative grammar for at least thirty years. Within the literature on Slavic syntax, Bulgarian has received special attention with regard to Superiority since the complex constraints that govern the ordering of fronted *wh*-words in Bulgarian multiple *wh*-interrogatives have been taken to be of great theoretical significance within GB/MP research (Bošković 1993; Chomsky 1973; Pesetsky 1987; Richards 1997). Still, there is considerable disagreement over the acceptability of certain examples and overall, over the stability of the Superiority effects, just as much as about the best account for the ordering constraints on Bulgarian *wh*-questions.¹

In this paper, I present a formal account that differs substantially from the above-mentioned ones, most crucially in that I take so called ‘Superiority effects’ to be – at least in large part – due to topicality. This paper thus aligns with others who have raised doubt about the Superiority as a syntactic axiom (e.g. Ginzburg and Sag 2000:247f. for English; King 1995:56f. for Russian; among many). The current work is then motivated by the question ‘What is Superiority?’. In addressing this question, I use earlier work as a starting point.

The paper is structured as follows. In section 2, I provide the relevant background on topic- and focus-fronting, clitic doubling, multiple *wh*-interrogatives and so called ‘Superiority effects’. Section 2.3 discusses clitic doubling of *wh*-phrases and links it to topic-fronting (cf. Jaeger to appear). In section 3, I develop an analysis for topic-fronting in- and outside of *wh*-interrogatives, including the data introduced in section 2.3. Finally, section 4 contains a summary and conclusions.

⁰My heartfelt thanks go to Ivan Sag, Veronica Gerassimova (without them, this paper would not have been possible), Loren Billings, Mila Dimitrova-Vulchanova, Mariana Lambova, Mila Tasseva-Kurktchieva for their critical feedback and valuable discussions. I also would like to thank Lev Blumenfeld, Elisabeth Norcliffe, and the audiences at the FASL-12 and HSPG 2003 conferences. The usual disclaimers apply.

¹To name a few papers with conflicting claims regarding Bulgarian Superiority data: compare Billings and Rudin (1996, 1998) vs. Bošković (1998b,a) vs. Grewendorf (2001) vs. Pesetsky (1987).

2 Background

In this section, I briefly introduce some relevant background. Section 2.1 describes multiple topic- and focus-fronting and its relation to clitic doubling (henceforth CD) in declarative clauses. Section 2.2 summarizes the relevant claims made in the literature about Superiority in multiple *wh*-interrogatives. The reader familiar with the literature on Bulgarian syntax will not miss anything by skipping over these two sections. In section 2.3, I summarize the data from Jaeger (to appear), showing CD in *wh*-interrogatives.

2.1 Discourse Function Fronting and Clitic Doubling

In Bulgarian, certain discourse functions (topic and focus) are marked in syntax by means of fronting of the respective constituents I will refer to this process as *discourse function fronting* (DF-fronting). In Bulgarian and other Slavic languages, fronted topics precede fronted foci. Examples for Bulgarian and Russian are given below:

- (1) Decata MAMA šte vodi na cirk. [Bulgarian]
children-the_{TOP} mom_{FOC} will take to circus
The kids, MOM will take to the circus. [Lambova 2003b:1]
- (2) Ja k ANNE prišel. [Russian]
I to Anna arrived
I visited ANNA. [King 1995:207]

In colloquial Bulgarian and some other languages (e.g. Albanian and Greek; Kallulli 2001) *topic*-fronted object constituents are CDed, i.e. they are doubled by a clitic somewhere lower in the clause agreeing in person, number, gender and case.² CD is well-known from Romance languages (e.g. Rumanian, Italian, French, and Spanish) and the languages of the Balkan Sprachbund (e.g. Albanian, Bulgarian, Greek, Macedonian) among others. Although many different functions have been proposed for Bulgarian CD (for an overview, see Jaeger 2002), the literature clearly converges on the claim that CD marks topicality (e.g. Alexandrova 1997; Dimitrova-Vulchanova and Hellan 1995/1999; Jaeger and Gerassimova 2002; Leafgren 1997; Rudin 1997). Example (3), in which the fronted *Todor* is extracted out of a sentential subject, shows that topic-fronting is a long distance dependency. (4) shows that fronting and doubling of several constituents is possible. DOC stands for the direct object clitic and IOC for the indirect object clitic. Topic-fronted constituents and clitics are underlined.

- (3) Todor e jasno, [če Ivan go e vidjal]
Todor_{TOP} is clear that Ivan DOC_{3.SG.MASC} is seen
Todor, it is clear that Ivan has seen him.

²I restrict myself to object CD and ignore subject CD which is also possible in several of the above-mentioned languages.

- (4) Na Ivan knigata az mu ja dadox.
 to Ivan_{TOP} book-the_{TOP} I IOC_{3.SG.MASC} DOC_{3.SG.FEM} gave
I gave the book to Ivan. [Dimitrova-Vulchanova and Hellan 1998:xviii]

While CD of topic-fronted constituents is *obligatory* for colloquial Bulgarian (i.e. (4) would not be acceptable without the clitics), more formal registers of Bulgarian do generally avoid CD, as e.g. in (1) above. This variation will fall out of the analysis proposed here (cf. section 3.1).

2.2 Multiple *wh*-Interrogatives

Bulgarian *requires* all *wh*-phrases in non-echo questions to be extracted to the left periphery of the clause. In the case of embedded questions, *wh*-phrases can be extracted to the front of the embedding clause or to the front of the embedded clauses. In both cases they follow topics (Dimitrova-Vulchanova and Hellan 1995/1999; Rudin 1985). An example of an embedded question is given below:

- (5) Čudja se kâde kogo da izpratja.
 wonder_{1.SG} REFL where whom to send
I wonder whom to send where. [Pavlov 2000:134]

Multiple *wh*-interrogatives have often been discussed under the keyword Superiority (Chomsky 1973). As in the case of many other languages (e.g. English and Russian), in Bulgarian, too, Superiority has been taken to enforce certain ordering restrictions on fronted *wh*-phrases. However, it is still unclear to which extent Superiority applies to Bulgarian *wh*-interrogatives. Many competing hypotheses have been proposed since Rudin (1985) who was the first to address the topic (for Bulgarian) within a generative framework. Before I proceed, I summarize three influential hypotheses with conflicting predictions (see also Jaeger to appear).

In (6), the subject *wh*-phrase supposedly has to precede the direct and indirect object *wh*-phrases, but the latter two can order freely in the second and third position. This is taken to also hold for sentences without a subject *wh*-phrase.

- (6) a. Koj kogo kak e celunal?
 who whom how is kissed
Who kissed whom how?
 b. Koj kak kogo e celunal?
 c. *Kogo koj kak e celunal?
 d. *Kak koj kogo e celunal?

Bošković (1993, 1998b,a) and Lambova (2003b)

- (a) The *first wh*-phrase in *wh*-interrogative is subject to Superiority.
 (b) In a multiple *wh*-interrogatives, all *wh*-phrases after the first order freely.

However, Grewendorf (2001:97) gives the following example to show that non-subject *wh*-phrases can actually order freely if there is no subject *wh*-phrase:

- (7) a. Kakvo na kogo e dal Ivan?
what to whom is given Ivan
What has Ivan given to whom?
- b. Na kogo kakvo e dal Ivan? [Grewendorf 2001:97]

Grewendorf (2001:97)

- (a) *Subject wh*-phrases are subject to Superiority.
(b) In a multiple *wh*-interrogatives, all other *wh*-phrases order freely.

This claim is further revised by Billings and Rudin (1998:5-6) who introduce examples of sentences with non-external subjects, such as (8), and examples of psych verbs with obligatory clitic doubling, such as (9), to show that animate object *wh*-phrases can sometimes precede subject *wh*-phrase.

- (8) a. Kakvo kogo e udarilo?
what whom is hit
What hit whom?
- b. Kogo kakvo e udarilo? [Billings and Rudin 1998:5]
- (9) a. Koj na kogo mu xaresva?
who to whom IOC pleases
Who likes whom?
- b. Na kogo koj mu xaresva? [Billings and Rudin 1998:6]

Billings & Rudin (1996:46,1998)

- (a-1) *External* [+human] subject *wh*-phrases are subject to Superiority.
(a-2) If there is no external subject, [+human] *wh*-phrases precede [-human] *wh*-phrases.
(b) All remaining *wh*-phrases order freely.

2.3 Clitic Doubling in *wh*-Interrogatives

In this section, I present data that constitute a systematic violation of Bošković's claim and cannot be accounted for by Billings and Rudin's animacy hypothesis either. These data were first introduced and discussed in more detail in Jaeger (to appear). I first summarize the phenomenon and then describe the analysis proposed in Jaeger (to appear).

2.3.1 The Phenomenon

As already mentioned, colloquial Bulgarian exhibits CD, which in some cases (e.g. for topic-fronted objects) is obligatory. But aside from the well documented cases of CD in non-interrogatives, *wh*-phrases in interrogatives can be CDed, too. Interestingly, CD in *wh*-interrogatives licenses a clear violation of Superiority, as shown in (10a) and (11a). In both examples, the object *wh*-phrase precedes the subject *wh*-phrase – contrary to what is predicted by any of the analyses discussed in the previous section. Note that the direct object clitic (DOC) is obligatory. In the default order, given in (10b) and (11b), the subject *wh*-phrase precedes the object, and CD is unacceptable or at least not preferred (compared to the (a)-variants).³

- (10) a. Kogo koi ženi *(go) poznaxa?
 whom which_{PL} women_{DEF} DOC_{3.SG.MASC} recognized_{3.PL}
Whom did which women recognize?

b. Koi ženi kogo (?go) poznaxa?

- (11) a. Kogo kakvo *(go) ubi?
 whom what DOC_{3.SG.MASC} killed_{3.SG}
Whom did what kill?

b. Kakvo kogo (?go) ubi?

The effect of CD is further illustrated by (12) which contains two 3.SG *which*-phrases. With the DOC the first *wh*-phrase, *koj máž*, is interpreted as object. Without the DOC the first *wh*-phrase is interpreted as subject. Note that the argument status of the *which*-phrases in (12) cannot be determined by means of gender or case. The verb form in (12) does not mark gender and *which*-phrases – just like almost all NPs in Bulgarian – do not have overt case marking.

- (12) Koj máž koja žena (go) običa?
 which man which woman DOC_{3.SG.MASC} loves
 Without DOC: *Which man_{SUBJ} loves which woman_{OBJ}?*
 With DOC: *Which woman_{SUBJ} loves which man_{OBJ}?*

CD of a *wh*-phrase is neither limited to certain kinds of verbs (e.g. there are no Aktionsart restrictions) nor is it dependent on the animacy of the arguments (the latter is illustrated by (10) above).

³This generalization seems to be less clear for overtly D-linked *wh*-phrases (so called ‘which’-phrases), which seem to be acceptable with CD even if they are not fronted.

2.3.2 The Function: Marking of Topicality

The analysis of the above data put forward in Jaeger (to appear) states, in a nutshell, is that CD of *wh*-phrases, like CD of other types of fronted objects, marks topicality. The topic of a question is what the question *primarily requests information about* (for topics in interrogatives, see also Leafgren 1997:127; Steedman 2000:659). The claim that CD of *wh*-phrases marks topicality is supported by a range of arguments that are discussed in detail in Jaeger (to appear). Although topicality in questions may – on the first sight – appear to be an odd claim, it has nonetheless been argued for under labels like ‘D-linking’ for e.g. Rumanian (Comorovski 1996), Russian (Scott 2003), and German (Grohmann under review).⁴

In other words, I have argued that CDed *wh*-phrases are topical and that CD in *wh*-interrogatives works just like CD outside of *wh*-interrogatives. A possible objection to this claim could be that it has been argued that only *one wh*-phrase can be CDed (Dimitrova-Vulchanova and Hellan 1998, 1995/1999), whereas I have shown above that Bulgarian declaratives can have multiple fronted topics and that all fronted objects are CDed in the colloquial register. Dimitrova-Vulchanova and Hellan (1998:xxi) cite (13a) to show that “in constituent questions with many *wh*-items, one, but not more than one, clitic may occur agreeing with the respective *wh*-constituent”. In addition, Dimitrova-Vulchanova and Hellan (1995/1999:37) mention (13b) to illustrate that, more generally, only one constituent (regardless of whether it is an *wh*-phrase or not) in a *wh*-interrogative can be doubled.

- (13) a. Na kogo kakvo mu (*go) dadoxa?
 to whom what IOC_{3.SG} DOC_{3.SG.NEUT} gave_{3.PL}
What did they give to whom? [Dimitrova-Vulchanova and Hellan 1998:xxii]
- b. Knigata na kogo (*mu) ja dadoxa?
 books-the_{FEM} to whom IOC_{3.SG} DOC_{3.SG.FEM} gave_{3.PL}
To whom did they give the books? [D.V. and H. (1995/1999:37)]

However, it turns out that questions with more than two *wh*-phrases are much more compatible with CD of *two* object *wh*-phrases (Mila Vulchanova, p.c.):

- (14) ?Na kogo kakvo koga mu go dadoxa?
 to whom what when IOC_{3.SG} DOC_{3.SG.NEUT} gave_{3.PL}
To whom did they give what when? [Mila Vulchanova, p.c.]

To sum up, although topic-marking in *wh*-questions is subject to some additional constraints⁵, in principle multiple topic-fronting *is* possible for *wh*-interrogatives.

⁴For a more general discussion of topicality and D-linking in *wh*-interrogatives, see also Kuno and Takami (1993); Grohmann (1998); Boeckx and Grohmann (2003).

⁵Recall that, after all, (13a) is possible with both clitics in declaratives, that is if both *wh*-phrases are substituted by lexical NPs, as in (4).

2.4 Summary

In this section, I have provided a brief summary of the overall configuration of the left periphery in the Bulgarian clause. I have paid particular attention to what I take to be topic-fronting of CDed object *wh*-phrases. The type of Superiority violations mentioned in section 2.3 cannot be accounted for even by those analyses that predict *some* violations of strict Superiority (e.g. Billings and Rudin 1996, 1998; Grewendorf 2001; Pesetsky 2000).

The remainder of the paper lays out a formal analysis of the left periphery, especially topic-fronting (within as much as outside of *wh*-interrogatives). I also gather further support for an extension of the above-stated hypothesis to non-object *wh*-phrases. Whereas CD provides a way of identifying topical object phrases, topical non-object phrases do not have a comparable morphological marking in Bulgarian. There is, however, some support for topic-fronting of non-object *wh*-phrases, which I discuss in section 3.2.

3 The program

An adequate analysis of the left periphery of the Bulgarian clause (which is the target of such phenomena as DF-fronting and *wh*-fronting) has to account for the following issues: (A) the correct order of fronted constituents, i.e. (A-1) topics precede non-topics; (A-2) topic-fronted non-*wh*-phrases can precede the *wh*-cluster in Bulgarian *wh*-questions (cf. (13b) in section 2.3.2); it also has to account for the facts that, in colloquial Bulgarian, (B-1) topic-fronted objects *must* be CDed and (B-2) focus-fronted objects *cannot* be CDed. For colloquial Bulgarian, this in turn raises the following questions: (C) what information object clitics contain in their lexical entry, and (D) how this information is passed from the clitics to the constituents on the left periphery of the clause. Taken together, questions (C) and (D) address the question of how an analysis can guarantee that object clitics have to agree with the topic-fronted constituent they double (see above) and that the constituent an object clitic agrees with must be topical.

Questions (B-1), (C) and (D) are addressed in section 3.1. The issues raised under (A) turn out to be quite intricate. They are discussed in detail in section 3.2. The remaining point (B-2) is addressed in section 3.3. I provide the formal constraints on the constructions of the left-periphery (e.g. the *wh*- and topic-clause types) and briefly sketch how the different parts of the proposed analysis interact. I will assume familiarity with the framework proposed in Ginzburg and Sag (2000) as well as with the idea of Linear Syntax (Reape 1994; Kathol 1995, 2000).

3.1 The Extraction Site: Colloquial \neq Formal Bulgarian

As I have already pointed out above, formal and colloquial Bulgarian seem to behave fairly similar much alike with respect to DF-fronting – except for the fact that colloquial Bulgarian requires CD of topic-fronted object constituents. In other

words, in terms of the relation between the ‘extraction site’ (i.e. the site from which something is extracted) in the clause and the ‘extraction target’ (i.e. the left periphery), object clitics have the same distribution as gaps. In light of this, I suggest the following. First, Bulgarian object clitics (in their function as discussed here) should be treated as phonetically non-empty gaps. Second, the ordering on the fronted field should be defined in terms of topicality rather than with direct reference to CD, which is only *one way to mark topicality* (i.e. for objects in colloquial Bulgarian). The second point will receive more attention in the next section, but I ask the reader to keep it in mind while reading the current section.

What does this mean for clitics? Somehow the lexical entry of a clitic introduces an element into the VP’s SLASH set and state that this element is topical and that it must have the right agreement features (i.e. the agreement features that are expressed in the clitic). Here I do not wish to discuss whether clitics in Bulgarian are adjoined to the verb in morphology or in syntax.⁶ For simplicity’s sake, let us assume that clitics are adjoined to the verb in syntax⁷. Furthermore, given that, whenever a topical object is extracted in colloquial Bulgarian it has to be CDed, I postulate that colloquial Bulgarian (unlike more formal registers) has no way of introducing topical object gaps. Note that this is the answer to (B-1) raised at the beginning of section 3, i.e. ‘Why do fronted topics have to be CDed?’ A clitic identifies its own LOCAL value as the only element of its SLASH set and further determines that the CONTENT of this element is a member of the TOPICS set. The template for an object clitic is given in (15).

(15) Schematic template for object clitics

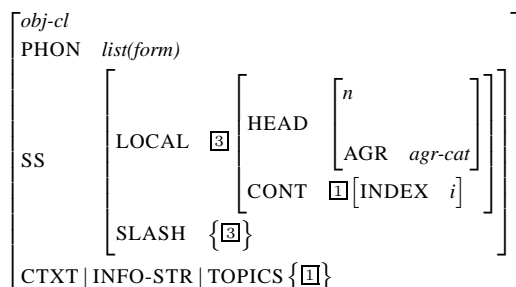

I assume a construction which identifies clitics with items on the verb’s ARG-ST. Thus whichever fronted constituent fills the ‘gap’ introduced by a clitic will be identified as a specific argument of the verb. The SLASH value percolates up to the clausal level due to the non-LOCAL Amalgamation Constraint (Ginzburg and

⁶This still appears to be an unresolved issue in the literature and is not relevant for this paper (see Franks and King 2000 for an overview over mostly syntactic approaches; for a recent morphological approach, see O’Connor 2002; for a similar approach in HPSG, see Miller and Sag 1997).

⁷In Bulgarian, object clitics are part of the so called *predicate clitic cluster* which is always verb adjacent. One could therefore propose a construction that combines the verb with all clitics to form the predicate clitic cluster. The construction identifies clitics with elements of ARG-ST and cancels the corresponding COMPS in the resulting predicate clitic cluster phrase.

Sag 2000:398), which collects all daughters' SLASH sets into the head's SLASH set. Therefore, the CDed phrase has to be topical since the clitic identifies its SLASH element as topical.⁸ Any element of TOPICS is passed up to the clause by the *Information Structure Principle* (ISP), which is defined as a constraint on headed phrases (i.e. the type *hd-ph*; cf. Ginzburg and Sag 2000):

(16) Information Structure Principle (ISP)

For each information structural feature F (such as e.g. TOPICS or FOCI), the value of F of a headed phrase's (hd-ph) mother is the union of all its daughters' F values:

$$hd-ph \Rightarrow \left[\begin{array}{l} \text{DTRS} \left\langle \left[\begin{array}{l} \text{CTXT} | \text{INFO-STR} | \mathbf{F} \left[\Sigma_1 \right] \\ \text{CTXT} | \text{INFO-STR} | \mathbf{F} \left[\Sigma_n \right] \end{array} \right], \dots \right\rangle \\ \text{CTXT} | \text{INFO-STR} | \mathbf{F} \left[\Sigma_1 \right] \cup \dots \cup \left[\Sigma_n \right] \end{array} \right]$$

Since clitics identify their CONTENT to be a member of TOPICS, the ISP ensures that this information is passed up to the clausal level. In section 3.3, it will become clearer precisely how this in turn forces the extraction target to be a member of TOPICS. In sum, colloquial Bulgarian has only one way to realize the extraction site of a topic-fronted object, namely via an object clitic. I have sketched the information provided by clitics (agreement, topicality of co-indexed item, and indirect argument identification). Formal Bulgarian, on the other hand, does not have clitics because but allows topical object gaps. In other words, colloquial and formal Bulgarian differ at the extraction *site*. Note that I have refrained from introducing a CLITIC feature (cf. Avgustinova 1997). Instead the absence or presence of CD is represented indirectly. If an object is CDed it is deleted from the COMPS list and required to be topical. This approach is a priori preferable to one that employs a CLITIC feature, and will in addition prove elegant once I provide the analysis for the extraction *target* in section 3.3.

3.2 The left periphery of the Bulgarian clause

In section 2.1, I showed that Bulgarian has two types of DF-fronted constituents, namely topics and foci. The former always precede the latter. Similarly, in questions, CDed *wh*-phrases, which have been argued to be topical, have to precede the non-CDed *wh*-phrases. Thus we already know that $[-wh; +top] \prec [-wh; -top]$ (i.e. non-*wh*-phrase 'topicalization') and $[+wh; +top] \prec [+wh; -top]$ (i.e. *wh*-phrase 'topicalization').⁹ We also know that $[-wh; +top] \prec [+wh; -top]$ (i.e. non-*wh*-phrase topic-fronting before the *wh*-cluster). Note that we do not know whether $[-wh; +top] \prec [+wh; +top]$ (i.e. topic-fronted non-*wh*-phrases precede topic-fronted *wh*-phrases) simply because this combination is very difficult or

⁸Note that I treat topics in a slightly different way from that proposed in Engdahl and Vallduví (1996) in that I take topics to be *semantic objects* (i.e. of type *sem-obj*; cf. Ginzburg and Sag 2000:387) rather than signs (see also Jaeger and Oshima 2002).

⁹I use $[+/- \alpha]$ purely as a convenient notation for the *descriptive generalizations*. The sign \prec denotes a linear precedence relation (a \prec b if 'a must precede b').

even impossible to get.¹⁰ The same difficulty holds for the relative order between non-*wh*-foci and *wh*-phrases. Rudin (1985:89) argues that focus-fronting is not possible in *wh*-questions. Pavlov (2000:142) provides (17) to show *wh*-fronting before a focus-fronted phrase (marked by the focus particle *li*) within a yes/no-question:

- (17) Kâde VČERA li bjaxa xuknali v tozi stud?
 Where yesterday_{FOC} FOC were rushed in this cold
Where had they rushed YESTERDAY in this freezing weather?

However, in the default order for (17) the *wh*-phrase *kâde* would follow the focus phrase *včera li* (Veronica Gerassimova, p.c.). Thus [+wh] | [-wh;+foc].¹¹ Note that, strictly speaking, no focus feature is needed to describe this order constraint. A preliminary version of the left periphery precedence constraints is given in (18).

(18) **Left periphery precedence constraints (preliminary version)**

[-wh;+top] | [+wh;+top] < [+wh;-top] | [-wh;-top]

The precedence relations in (18) constitute the issue raised at the beginning of section 3 under point (A). Next, I will discuss *splitting of the wh-cluster*, a phenomenon, which, I argue, reveals further evidence for the existence of topic-fronted *wh*-phrases.

Consider the following data, in which a phrase splits the *wh*-cluster. Lambova (2003c), building on Rudin (1988), shows that emphatic particles, parentheticals, and adverbs (both sentential and manner adverbs) can occur after the first but not after the second *wh*-phrase. Below I give one of her examples, where *navjarno* ('perhaps') splits the cluster of fronted *wh*-phrases. Lambova (2003a,c) has taken these data as evidence that the first *wh*-phrase (sometimes) does not form a constituent with the remaining *wh*-phrases:

- (19) a. Koj, navjarno, kâde koga šte porâča tortata?
 who perhaps where when will order cake-the
Who will perhaps have the cake made where when?
- b. *Koj kâde, navjarno, koga šte porâča tortata?
- c. *Koj koga, navjarno, kâde šte porâča tortata? [Lambova (2003c)]

Lambova (2003c) also gives several examples illustrating that the same phrases that can split a *wh*-cluster after the initial *wh*-phrase *cannot* do that if the question

¹⁰I leave it open as to whether there may be sentences containing both 'normal' and *wh*-topics, since I do not have enough data to decide this point. For some data that could possibly be taken to support that [+wh;+top] < [-wh;+top] *cannot* hold, see Lambova (2003c) who argues that non-*wh*-topics cannot follow the first *wh*-phrase.

¹¹I use 'a | b' to indicate that 'a and b can order freely'.

is preceded by a topic-fronted non-*wh*-phrase. The translations have been slightly changed to match the way other examples in this paper have been translated. Topic-marking is indicated by underlining (not given in the original examples):

- (20) a. Kakvo, kazvaš, koga iska šefât?
 what_{TOP} you-are-saying when wants boss-the
What, you're saying, does the boss want when? [Lambova (2003c)]
- b. *Šefât, kakvo, kazvaš, koga iska?
 boss-the_{TOP} what_{TOP} you-are-saying when wants
The boss, what, you're saying, does (he) want when? [Lambova (2003c)]

Although Lambova does not consider topic-fronting of *wh*-phrases, she provides examples showing that the same types of phrases that can split the *wh*-cluster (henceforth SPP for splitter-phrases) can also appear after fronted non-*wh*-topics (Lambova 2003a). For multiple topic-fronting as well, speakers seem to prefer SPPs between the topics and the *wh*-cluster (rather than after the first topic-fronted constituent):¹²

- (21) Na Maria (?obiknoveno) tortite (obiknoveno) koj i gi dava?
 to Maria_{TOP} usually cakes-the_{TOP} usually who IOC DOC gives
 Roughly: *To Maria the cakes, who (usually) gives (them) (to her?)*

I propose the following analysis. The SPPs in the above examples occur between topic-fronted constituents and non topic-fronted *wh*-phrases. *Wh*-phrases preceding an SPP are topic-fronted.¹³ This claim predicts that SPPs should be able to occur after an initial CDed object *wh*-phrase, since they are topical. This is indeed the case:

- (22) a. Kogo, naj-verojatno, koj *(go) obra?
 whom_{TOP} most-probably who DOC_{3.SG.MASC} robbed
 Intended: *Whom did most probably who rob?*
- b. Koj, naj-verojatno, kogo (*go) obra
 who most-probably whom_{TOP} DOC_{3.SG.MASC} robbed
 Intended: *Who did most probably rob whom?*

I thus take this to be evidence for the hypothesis stated above that SPPs *can* appear between CDed topical *wh*-phrases and the remainder of the *wh*-cluster.¹⁴

¹²The data seem to be far more complex since judgements depend on the kind of SPP that is chosen (Veronica Gerassimova, p.c.). Here, it only matters that there seem to be certain SPPs which occur after the topic-cluster. I also do not discuss occurrences of SPPs *following* the *wh*-cluster.

¹³Since SPPs can also adjoin to VPs, one has to be careful, since because of this a single non topic-fronted *wh*-phrase also 'precedes an SPP'. Above, I refer to SPPs that occur directly *before* the *wh*-cluster. For *wh*-interrogatives with two or more *wh*-phrases, this is unambiguously identifiable.

¹⁴One may ask why it is not possible to have two topical *wh*-phrases or one topical non-*wh*-phrase and a topical *wh*-phrase followed by an SPP. As already discussed above, Dimitrova-Vulchanova

While more data are needed to be certain, it seems plausible that non-object *wh*-phrases, e.g. *koj* in (19a) or *kakvo* in (20a), are topic-fronted, just as CDed object *wh*-phrases are, e.g. *kogo* in (22a). This would simplify the formulation of the left periphery precedence constraints, thereby allowing a uniform analysis for SPP-placement. Furthermore, the proposed analysis of (at least some) initial *wh*-phrases as topics provides an explanation for (at least some) so-called Superiority effects. Rather than restricting *wh*-topic-fronting to CDed object *wh*-phrases, I assume (based on the data presented in this section) that topical *wh*-phrases of any kind precede non-topical *wh*-phrases. This parallels the data known from declaratives where topics precede foci. The revised and simplified version of the left periphery precedence constraints is the following:

(23) **Left periphery precedence constraints (final version)**

[+top] < SPP < [-top]

The next section addresses those parts of (23) that are crucial to multiple *wh*-questions with and without CD.

3.3 The Extraction Target: Colloquial = Formal Bulgarian

Below I present an analysis of the linear order constraints on the left periphery described in the previous section. After considering a range of different analyses (some rather hierarchical, some purely linear), I have come to the conclusion that the best analysis makes reference both to linear order constraints and to a hierarchy of phrases on the left periphery. Linear order is needed to provide an elegant description of the phenogrammatical properties of the left periphery, and a hierarchical organization proves necessary in order to capture its tectogrammatical properties.¹⁵ I therefore adopt a version of Linearization-based Syntax (cf. Reape 1994; Kathol 1995, 2000), which makes use of the idea of topological fields. Before I proceed, let me briefly summarize the core of Kathol's proposal and where the approach taken here deviates from his (for further details, see Kathol 2000).

In addition to the standard features, each construction/phrase/word is assumed to contain an ORDER DOMAIN feature (henceforth DOM). I follow Reape (1994) and Donohue and Sag (1999) – and deviate from Kathol (1995:127) and Kathol (2000:99-100) – in that I take the value of DOM to be a list of *signs*. The advantage of this stems from the fact that the information-structural status of DOM elements has to be accessible for ordering constraints (I elaborate on this below). I adopt the idea of topological fields (Kathol 1995, 2000). The fact that a given DOM element has to be realized in a specific topological field is encoded in the type of that element (following Kathol 2000). That is, DOM elements are of type *sign* and of type

and Hellan (1998, 1995/1999) have shown that it is extremely difficult to get several topics in *wh*-questions. Adding an SPP does not make the sentence less complex – eliciting such question becomes increasingly difficult. Note, however, that the same difficulties hold for two fronted non-*wh*-topics.

¹⁵For the distinction between 'phenogrammatical' vs. 'tectogrammatical' representations in linguistics, see Dowty (1996).

topo and therefore “positionalized signs” (Kathol 2000:77). This also implies that all words must be of a specific *topo* type (i.e. words specify in which topological field they can occur). DOM values are handed up to constructions (although the order within the DOM list may change). Thus the *topo* types of all DOM elements are available at the constructional level and ultimately at the clausal level. Constructions can determine or constrain the *topo* type of any of their daughters. For example, the filler constructions for the left periphery could specify their fillers to be of the left periphery field type. I will come back to this below. At any given point, the actual phonological realization of a construction/phrase corresponds to the order of elements in DOM (Reape 1994:155). The order within DOM is in turn determined by Linear Precedence (henceforth LP) constraints, which are sensitive to topological fields (i.e. the DOM elements’ types). To sum up, Topological LP constraints determine the linear order of phonological elements in a sentence, thereby accounting for phenogrammatical restrictions. At the same time, constructions/phrase types constitute the tectogrammatical structure of a sentence.

The Bulgarian type hierarchy assumed here for topological fields is shown in (24). Although by no means complete, all types *relevant to the current problem* are given. The left periphery contains all elements that are fronted because they bear discourse functions, such as topics and foci (including *wh*-phrases). In other words, a word can only appear in *lf* if it is marked to be part of a topic or focus of a sentence (or some other kind of discourse marking function, as assumed for SPPs). The main field contains everything between the left and the right periphery. The right periphery contains right-dislocated elements such as antitopics (cf. Lambrecht 1994), which I will not discuss here further. Even though Bulgarian, unlike German, lacks a ‘Satzklammer’ (sentence bracket), it shares with German the property that the left and right periphery are the target of (discourse function driven) extractions:

(24) The topological fields of the Bulgarian clause

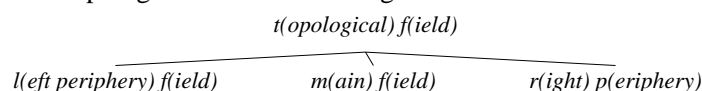

The ordering constraints observed in the previous section are captured by the LP Constraints in (25).

(25) Topological LP Statements for the Bulgarian clause

$$\begin{array}{l}
 \text{LP-1 (Bulgarian TF Constraint): } [lf] \prec [mf] \prec [rf] \\
 \text{LP-2 (Topics-First! Constraint): } \left[\begin{array}{l} lf \\ \text{CONT} \quad \boxed{\square} \\ \text{TOPICS} \quad \text{set} \uplus \{\boxed{\square}\} \end{array} \right] \prec \text{SPP: } [lf] \prec \left[\begin{array}{l} lf \\ \text{CONT} \quad \boxed{\square} \\ \text{TOPICS} \quad \text{set} - \{\boxed{\square}\} \end{array} \right]
 \end{array}$$

LP-1, the Bulgarian Topological Fields Constraint, states that elements in the left periphery precede elements in the main field, which in turn precede elements in the

right field. LP-2, the Topics-First! Constraint (henceforth TFC), is more complex in that it does not only make reference to topological fields. The TFC is effectively restricted to the left periphery (since it only states precedence constraints on elements of type *lf*). Within the left periphery, the TFC enforces the order that has been described in (23) in the previous section (i.e. topics have to precede non-topics, and SPPs appear after topics but before non-topics). Given the TFC, it also becomes clearer why it is advantageous that DOM elements be of type *sign*. As shown throughout this paper, especially in the previous section, the linear order of elements in the left periphery of the Bulgarian clause is clearly sensitive to information structure, most clearly to topicality. It thus seems as good or better a way to encode this *linear* order constraint directly by means of LPs (such as the TFC) rather than, for example, in the tectogrammatical component of the grammar (i.e. by means of phrase structure in the widest sense). Another way to capture the fact that topics precede foci would be to assume two left periphery fields (cf. Dimitrova-Vulchanova and Hellan 1995/1999) and associate one with topics and the other one with focus. This approach would not be incompatible with the one that I adopt here but I prefer the latter because of its conceptual clarity. Furthermore, as I show further down, the approach taken here reduces the number of constructions that are required in order describe the left periphery.

Note that the LP rules do not make direct reference to *wh*-phrases. While the correct *ordering* of all fronted phrases is achieved via the TFC, I have yet to provide the tectogrammatical structure that explains how the extracted phrases on the left periphery (e.g. *wh*-phrases) are combined with the remainder of the clause.

In order to do that, I sketch the type hierarchy for the constructions of the left periphery and show how the extracted elements in, for example, a ‘topicalization’ clause or a multiple *wh*-question are combined with the remainder of the clause. For the reader’s orientation, the proposed type hierarchy for the Bulgarian clause is shown in (26). The two types *Bg-df-cl* and *Bg-wh-int-cl* correspond to the constructions for DF-fronting and *wh*-interrogatives, respectively.

(26) Type hierarchy for the left-periphery of the Bulgarian clause (non-leaf nodes)

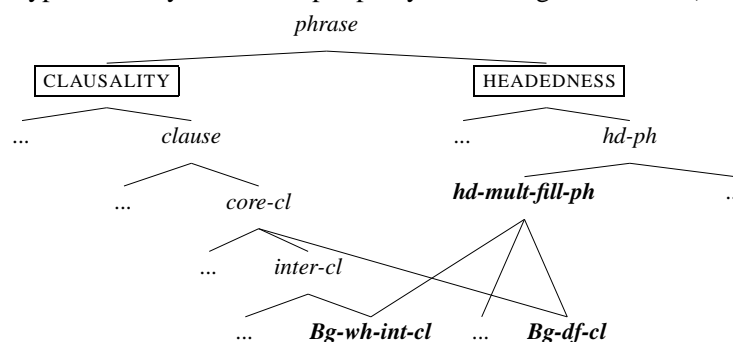

I begin the discussion of the new types with *hd-mult-fill-ph*, an extension of the En-

glish *hd-fill-ph* that allows *multiple* fillers instead of just one. A similar type will be needed for any kind of multiple fronting language (e.g. Serbo-Croatian, Russian, Romanian). The *hd-mult-fill-ph*, as defined in (27), describes a flat structure with multiple non-head daughters (cf. Ginzburg and Sag 2000:364). Like the English *hd-fill-ph*, the *hd-mult-fill-ph* is a subtype of *hd-ph* (i.e. *hd-mult-fill-ph* is a headed phrase).

(27) Bulgarian *hd-mult-fill-ph*

$$\left[\begin{array}{l} \text{hd-mult-fill-ph} \\ \text{SS | SLASH } \boxed{\Sigma_1} \\ \text{DTRS } \left\langle \left[\text{LOC } \boxed{1} \right], \left[\text{LOC } \boxed{2} \right], \dots \left[\text{LOC } \boxed{n} \right], \boxed{0} \right\rangle \\ \text{HD-DTR } \boxed{0} \left[\begin{array}{l} \text{LOC | HEAD } v \\ \text{SLASH } \left\{ \boxed{1}, \boxed{2}, \dots, \boxed{n} \right\} \uplus \boxed{\Sigma_1} \end{array} \right] \end{array} \right]$$

The constraints of *hd-mult-fill-ph* are inherited by the type for DF-fronting clauses (*Bg-df-cl*) and the type for *wh*-clauses (*Bg-wh-int-cl*). I discuss those two new types in turn.

The *Bg-df-cl* type is very similar to the English *top-cl* suggested in Ginzburg and Sag (2000:379). It is a head-filler construction, and all its fillers' WH values must be empty (this guarantees that *wh*-interrogative phrases cannot be fillers in *Bg-df-cl*). Each filler has to correspond to a SLASH element of the HD-DTR. The mother's SLASH value is the HD-DTR's SLASH value after all the fillers' LOCAL values have been removed from it. Unlike the English *top-cl*, *Bg-df-cl* enables both topic and focus fronting. The Discourse Configurationality Constraint (DCC) in (28) states that the CONTENT values of all non-head daughters of the *Bg-df-cl* must be either a member of TOPICS or FOCI:

(28) Discourse Configurationality Constraint (DCC) on *Bg-df-cl*

$$\text{Bg-df-cl} \Rightarrow \left[\begin{array}{l} \text{DTRS } \left\langle \left[\text{LOC | CONT } \boxed{C_1} \right], \dots, \left[\text{LOC | CONT } \boxed{C_n} \right], \boxed{1} \right\rangle \\ \text{HD-DTR } \boxed{1} \\ \text{CTXT | INFO-STRUC } \left[\begin{array}{l} \text{TOPICS } \left\{ \boxed{C_1}, \dots, \boxed{C_k} \right\} \cup \text{set} \\ \text{FOCI } \left\{ \boxed{C_{k+1}}, \dots, \boxed{C_n} \right\} \cup \text{set} \end{array} \right] \end{array} \right]$$

Note that nothing prevents the daughters from being members of both TOPICS *and* FOCI. This allows for 'newly introduced topics' (e.g. the optional *set* of TOPICS could in principle contain any of the CONTENT values $C_{k+1} \dots C_n$). 'New topics' (here, also [+top;+foc] elements) are indeed possible in Bulgarian (as in English left-dislocations; cf. Keenan-Ochs and Schieffelin 1976). Note further that instances of *Bg-df-cl* are also subject to the ISP because *Bg-df-cl* is a subtype of *hd-ph*. This implies that the TOPICS and FOCI values of *Bg-df-cl* correspond to the union of the TOPICS and FOCI values of its daughters.

Thus, if both topics and foci (and possibly other discourse functions) are fronted by the same construction, how, one may ask, can the correct order of DF-fronted elements be predicted given that the *Bg-df-cl* does not place any direct restrictions on the order of its DOM elements? This brings us back to the TFC, stated in (25) above. Since the linear ordering is done by the TFC, the *Bg-df-cl* type only has to state that the DOM elements corresponding to its fillers must be of type *lf* (i.e. that the fillers must be realized within the left periphery field). This is achieved by the Left Periphery Domain Condition (henceforth LPDC; for the notion of Domain Conditions, cf. Kathol 2000) formalized in (29) below. While the LPDC states that the DOM value corresponding to filler daughters must be of type *lf*, the TFC orders these DOM elements (and thereby determines the phonological realization), so that topics precede non-topics (e.g. ordinary focus-fronted phrases and *wh*-phrases, as long as the latter are not topic-fronted). Because not only the *Bg-df-cl* but (as I will show below) also the *Bg-wh-int-cl* is subject to the LPDC, I state this constraint on their common supertype *hd-mult-fill-ph*.

(29) The Left Periphery Domain Condition (LPDC) on *hd-mult-fill-ph*

$$hd-mult-fill-ph \Rightarrow \left[\begin{array}{l} \text{DTRS} \langle \boxed{1} \dots, \boxed{n}, \boxed{0} \rangle \\ \text{HD-DTR} \boxed{0} \\ \text{DOM} \langle \boxed{1}[lf], \dots, \boxed{n}[lf], \boxed{0} \rangle \end{array} \right]$$

At this point one may wonder why the order among topics and foci is not directly encoded via the *Bg-df-cl*. Recall, however, that Bulgarian also allows for topic-fronted *wh*-phrases. These phrases cannot be daughters of *Bg-df-cl*. Instead, like other non-topical *wh*-phrases, they are fillers in the Bulgarian *wh*-interrogative construction (*Bg-wh-int-cl*). If the ‘topics must precede foci’ constraint were postulated on *Bg-df-cl* (and maybe even *Bg-wh-int-cl*) it would not be possible to derive the fact that topics precede foci in the *whole left periphery*.¹⁶ On the contrary, for the account proposed here, this is not a problem at all. As a matter of fact, everything that is necessary to predict the correct ordering of fronted phrases has already been given above.

Like the *Bg-df-cl* type, *Bg-wh-int-cl* inherits the LPDC from *hd-mult-fill-ph*. This predicts that *wh*-phrases in *wh*-interrogatives have to appear in the left periphery where they are subject to the same linear order constraint as DF-fronted phrases (i.e. the TFC). Here, I do not discuss the details of the *wh*-interrogative construction but merely summarize the formal details for the interested reader. I follow in essence what has been proposed in Ginzburg and Sag (2000). I adopt the Interrogative Retrieval Constraint (Ginzburg and Sag 2000:365) which ensures that, in a question, at least one element of PARAMS is retrieved from the HD-DTR’s STORE. Next, I update the Filler Inclusion Constraint (FIC; Ginzburg and Sag 2000:228),

¹⁶Accounts that rely on separate types for topic- and focus-fronting and encode linear order directly via those types (rather than via Topological LPs) run into similar problems since there is no easy way to predict the correct order of application for the two construction types.

which guarantees that the extracted *wh*-phrases contribute their WH values to the PARAMS set of the mother. The new version, the Multiple Filler Inclusion Constraint (MFIC) given in (30), is compatible with the *hd-mult-fill-ph*. It also differs from the FIC in that it does *not* allow optional retrieval of additional *params* (which could only come from in-situ *wh*-phrases). The PARAMS value of Bulgarian *wh*-interrogatives is determined exclusively by the WH values of its filler daughters.

(30) Multiple Filler Inclusion Constraint (MFIC) on *Bg-wh-int-cl*

$$Bg\text{-}wh\text{-}int\text{-}cl \Rightarrow \left[\begin{array}{l} SS | LOC | CONT \quad \left[\text{PARAMS} \quad \{ \pi_1 \} \uplus \dots \uplus \{ \pi_n \} \right] \\ DTRS \quad \quad \left\langle \left[\text{WH} \quad \{ \pi_1 \} \right], \dots, \left[\text{WH} \quad \{ \pi_n \} \right], [\dots] \right\rangle \end{array} \right]$$

I also assume a couple of constraints defined on *words* to guarantee that (a) only fillers in filler-extraction constructions can have non-empty WH values, and (b) all *wh*-phrases with non-empty WH values have to be fronted (cf. WHSP, WHC; Ginzburg and Sag 2000:189).¹⁷

To sum up, the tectogrammatical analysis of Bulgarian *wh*-interrogatives closely resembles the analysis for English *wh*-interrogatives proposed in Ginzburg and Sag (2000). The *params* contributed by the *wh*-phrases' WH features (i.e. the semantic content of the *wh*-phrases) are added to the mother's PARAM value. This and the fact that the mother's CONTENT value is defined to be of type *question* (that is an abstraction over its head daughter's CONTENT value, which must be a *proposition*; cf. Ginzburg and Sag 2000) create the necessary question semantics whenever *wh*-phrases are fronted. The two main differences to Ginzburg and Sag's approach to the left periphery are that (a) Bulgarian has a *hd-mult-fill-ph*, i.e. it allows multiple DF- and *wh*-fronting (a language-specific difference), and (b) the ordering of fronted constituents (including the *wh*-cluster) is achieved by Topological LP Constraints (a theoretical choice which I have motivated above).

I have already stated that the daughters of the *Bg-wh-int-cl* and *Bg-df-cl* constructions are subject to the LPDC. Thus all topic-fronted phrases (*wh*-phrases or not) will be ordered before SPPs (which I assume to be introduced by a separate construction I do not discuss here) by the TFC, as stated above in (25). 'Normal' *wh*-phrases (i.e. non-topical ones) are correctly predicted to follow SPPs just as (non-topical) foci are predicted to follow SPPs.

Finally, let me come back to the claim I made at the end of section 3.1, namely that it would be advantageous to avoid a specific CLITIC feature. Instead, I suggested that colloquial Bulgarian realizes topical object extraction with an object clitic at the extraction site, whereas formal Bulgarian allows topical object gaps.

¹⁷In addition to the changes just mentioned some additional small changes have to be made: (a) the constraint on English subject *wh*-clauses that handles the gap-filling for subject gaps (cf. Ginzburg and Sag 2000:237) has to be updated to be compatible with *hd-mult-fill-ph*, and (b) the Inversion constraint (INVC; cf. Ginzburg and Sag 2000:231) is irrelevant for Bulgarian. Since I am not concerned with infinitival *wh*-questions here, I will not discuss the necessity of the Optional *Pro* Condition (OPC; cf. Ginzburg and Sag 2000:231).

While *Bg-df-cl* allows both topical and non-topical fillers, only topical ones can be CDed.¹⁸ This is sufficient to capture the fact that, in colloquial Bulgarian, topic-fronted phrases will have to be CDed further down in the clause (since this was the only way to introduce a topical object gap). Thus, the current proposal for the left periphery (i.e. the extraction target) holds unchanged for both the formal and the colloquial registers of Bulgarian.

4 Conclusion

I have provided a general account of the Bulgarian left periphery, focusing on clitic doubling (CD) in *wh*-questions. While fronting of constituents bearing discourse functions is well-researched for non-interrogatives (see references in section 2.1), the possibility of topical *wh*-phrases has mostly been ignored in the literature on Bulgarian.¹⁹ Similar ideas have, however, occasionally been mentioned – mostly under the related label of D-linking – for other languages (e.g. Comorovski 1996; Grohmann 1998; Pesetsky 1987; Scott 2003).

After providing an argument for the general possibility of topic-fronting of *wh*-phrases, be they CDed or not (cf. section 3.2), I outlined a formal account of the Bulgarian left periphery (both the syntax and at least to some degree the semantics). The account employs topological fields and Linear Precedence Constraints defined on them, thereby distinguishing between pheno- and tectogrammatical properties of the left periphery. The analysis handles topic-fronting in and outside of *wh*-interrogatives as well as simple *wh*-interrogatives (without topic-fronting). As it stands, the overall framework assumed for the phenogrammatical analysis is a hybrid of Kathol (1995, 2000) on the one hand and Donohue and Sag (1999) on the other hand. What I really had in mind while drafting this analysis is, however, a version of construction grammar in which constructions are – among other things – responsible for organizing the information necessary for the linear ordering of their daughters. Although this is in some respect close to what I have proposed here, the current analysis would benefit from being restated (and refined) within a construction grammar framework of that type.

By basing the order of the fronted periphery on grammaticalized sensitivity to a general pragmatic concept (namely *topicality*), rather than on a morpho-syntactic feature of colloquial Bulgarian (i.e. CD), the present account works both for colloquial and formal Bulgarian and can in principle be extended to other languages with similar left periphery ordering (e.g. Russian, which also seems to allow topic-fronting of *wh*-phrases; cf. Scott 2003).

Finally and maybe most importantly, once we accept the hypothesis proposed in section 3.2 that *wh*-phrases followed by e.g. a parenthetical are topical (including subject *wh*-phrases, as in (19) and (22) above), this sheds new light on

¹⁸To be precise, CD *defines* whichever filler the clitic agrees with as topical.

¹⁹Dimitrova-Vulchanova and Hellan (1998, 1995/1999) and Jaeger (2002) mention CD in *wh*-interrogatives without directly relating it to topicality.

what has traditionally been called ‘Superiority effects’. Suddenly, the fact that subject *wh*-phrases occur clause-initially in a large majority of Bulgarian clauses ‘suspiciously’ resembles the fact that, cross-linguistically, subjects have been most frequently observed to be topics (cf. Lambrecht 1994:131f.). Thus I take it to be of crucial importance to investigate to which extent ‘Superiority’ (in Bulgarian as much as in other languages) can be accounted for by semantic and/or pragmatic facts.

References

- Alexandrova, G. 1997. Pronominal clitics as g(eneralized) f(amiliarity)-licensing agro. In *Formal Approaches to Slavic Linguistics: The Cornell Meeting, 1995*, ed. Browne et al., 1–31. Ann Arbor: Michigan Slavic Publications.
- Avgustinova, Tania. 1997. *Word order and clitics in Bulgarian*, volume 5 of *Saarbrücken Dissertations in Computational Linguistics and Language Technology*. Saarbrücken: DFKI.
- Billings, Loren, and Catherine Rudin. 1996. Optimality and superiority: A new approach to overt multiple-*wh* ordering. In *Formal Approaches to Slavic Linguistics, The College Park meeting, 1994*, ed. J. Toman, 35–60. Ann Arbor: Michigan Slavic Publications.
- Billings, Loren, and Catherine Rudin. 1998. Animacy and focus in Bulgarian *wh* questions. In *Proceedings of Conference on Slavic Morphosyntax, Bloomington, 1998*.
- Boeckx, Cedric, and Kleantes Grohmann. 2003. SubMove: Towards a unified account of scrambling and D-linking. In *Peripheries*, ed. David Adger; Cécile de Cat and George Tsoulas. Dordrecht: Kluwer.
- Bošković, Zeljko. 1993. On certain violations of the superiority condition, agro, and economy of derivation. *Journal of Linguistics* .
- Bošković, Zeljko. 1998a. Multiple WH-fronting and economy of derivation. In *The Proceedings of the Sixteenth West Coast Conference on Formal Linguistics held at the University of Washington*. Stanford: CSLI Publications.
- Bošković, Zeljko. 1998b. On the interpretation of multiple questions. Ms.
- Chomsky, Noam. 1973. Conditions on transformations. In *A Festschrift for Morris Halle*, ed. St. Anderson and P. Kiparsky. New York: Holt, Reinhart and Winston.
- Comorovski, Ileana. 1996. *Interrogative phrases and the Syntax-Semantics Interface*. Dordrecht: Kluwer Academics.
- Dimitrova-Vulchanova, Mila, and Lars Hellan. 1995/1999. Clitics and Bulgarian clause structure. In *Clitics in the languages of Europe*, ed. Henk van Riemsdijk, volume Empirical Approaches to Language Typology of *Language Typology*. Berlin: Mouton de Gruyter.
- Dimitrova-Vulchanova, Mila, and Lars Hellan. 1998. Introduction. In *Topics in south Slavic syntax and semantics*, ed. Mila Dimitrova-Vulchanova and Lars Hellan, ix–xxvii. Amsterdam and Philadelphia: John Benjamins Publishing.
- Donohue, Cathryn, and Ivan A. Sag. 1999. Domains in Warlpiri. In *Sixth International Conference on HPSG-Abstracts. 04–06 August 1999*, 101–106. Edinburgh. <http://www-csli.stanford.edu/~sag/papers/warlpiri.pdf>.

- Dowty, David. 1996. Towards a minimalist theory of syntactic structure. In *Discontinuous constituency*, ed. Harry Bunt and Arthur van Horck, 11–62. Mouton de Gruyter.
- Engdahl, Elisabet, and Enric Vallduví. 1996. Information packaging in hpsg. *Edinburgh Working Papers in Cognitive Science, Studies in HPSG* 12:1–31.
- Franks, Steven, and Tracy Holloway King. 2000. *A handbook of Slavic clitics*. Oxford: Oxford University Press.
- Ginzburg, Jonathan, and Ivan Sag. 2000. *Interrogative investigations. the form, meaning, and the use of English interrogatives*. Stanford: CSLI Publications.
- Grewendorf, Günther. 2001. Multiple wh-fronting. *Linguistic Inquiry* 32:87–122.
- Grohmann, Kleanthes. 1998. Syntactic inquiries into discourse restrictions on multiple interrogatives. *Groninger Arbeiten zur germanistischen Linguistik* 42:1–60.
- Grohmann, Kleanthes. under review. Top issues in questions. In *tba*. MIT Press.
- Jaeger, T. Florian. 2002. On the optional and obligatory realization of the Bulgarian direct object clitic. Ms, Stanford University.
- Jaeger, T. Florian. to appear. Topicality and superiority in Bulgarian wh-questions. In *Proceedings of Formal Approaches to Slavic Linguistics: The Ottawa meeting, 2003*, volume 12. Ann Arbor: Michigan Slavic Publications.
- Jaeger, T. Florian, and Veronica Gerassimova. 2002. Bulgarian word order and the role of the direct object clitic in LFG. In *Proceedings of the LFG02 Conference, Athens, July 3rd - 5th*, ed. M. Butt and T. King, 197–219. Stanford: CSLI Publications.
- Jaeger, T. Florian, and David Oshima. 2002. Towards a dynamic model of topic marking. In *Pre-proceedings of the Information Structure in Context Workshop, Stuttgart University, 15–16 November 2002*, 153–67. Stuttgart.
- Kallulli, Dalina. 2001. Direct object clitic doubling in Albanian and Greek. In *Comparative syntax of Balkan languages*, ed. M.L. Rivero and A. Ralli. Oxford University Press.
- Kathol, Andreas. 1995. Linearization-based German syntax. Doctoral Dissertation, Ohio State University.
- Kathol, Andreas. 2000. *Linear syntax*. Oxford: Oxford University Press.
- Keenan-Ochs, E., and B. Schieffelin. 1976. Foregrounding referents: A reconsideration of left-dislocation in discourse. In *Proceedings of BLS*, volume 2, 240–57. Berkeley.
- King, Tracy H. 1995. *Configuring topic and focus in russian. in: Dissertations in linguistics*. Dissertations in Linguistics. Stanford: CSLI Publications.
- Kuno, Susumu, and Ken-Ichi Takami. 1993. *Grammar and discourse principles: Functional syntax and gb theory*. Chicago: Chicago University Press.
- Lambova, Mariana. 2003a. On information structure and clausal architecture: Evidence from Bulgarian. Doctoral Dissertation, University of Connecticut. DRAFT.
- Lambova, Mariana. 2003b. On the interaction of multiple (non) wh-fronting and multiple topicalization in Bulgarian. In *The 26th Penn Linguistics Colloquium*.

- Lambova, Mariana. 2003c. When is splitting the wh-cluster in Bulgarian possible? In *Formal Approaches to Slavic Linguistics: The Amherst Meeting, 2002*, ed. Wayles Browne, Ji-yung Kim, Barbara H. Partee, and Robert Rothstein, volume 11, ? Ann Arbor: Michigan Slavic Publications.
- Lambrecht, Knud. 1994. *Information structure and sentence form. topic, focus, and the mental representations of discourse referents*. Cambridge: Cambridge University Press.
- Leafgren, John R. 1997. Bulgarian clitic doubling: Overt topicality. *Journal of Slavic Linguistics* 5:117–143.
- Miller, P., and Ivan A. Sag. 1997. French clitic movement without clitics or movement. *NLLT* 15:573–639.
- O'Connor, Rob. 2002. Clitics and phrasal affixation in Constructive Morphology. In *Proceedings of the LFG02 Conference, Athens, July 3rd – 5th*, ed. Butt and King, 315–332. Stanford: CSLI Publications.
- Pavlov, Ivan V. 2000. The non-argument functional field of Bulgarian clause structure. Doctoral Dissertation, NTNU Trondheim.
- Pesetsky, David. 1987. Wh-in-situ: Movement and unselective binding. In *The representation of (in-)definiteness*, ed. Reuland and Meulen, 98–129. Cambridge: MIT Press.
- Pesetsky, David. 2000. *Phrasal movement and its kin*, volume 37 of *Linguistic Inquiry, Monograph*. Cambridge: MIT Press.
- Reape, Mike. 1994. Domain union and word order variation in German. In *German in Head-Driven Phrase Structure Grammar*, ed. John Nerbonne; Klaus Netter and Carl J. Pollard, number 46 in CSLI Lecture Notes, 151–197. Stanford: CSLI Publications.
- Richards, Norwin. 1997. What moves where when in which language. In *MIT Working Papers in Linguistics*. MIT Press.
- Rudin, Catherine. 1985. *Aspects of Bulgarian syntax: Complementizers and wh constructions*. Columbus, Ohio: Slavica Publishers.
- Rudin, Catherine. 1988. On multiple questions and multiple wh fronting. *Natural Language and Linguistic Theory* 6:445–502.
- Rudin, Catherine. 1997. AgrO and Bulgarian pronominal clitics. In *Formal Approaches to Slavic Linguistics: The Indiana meeting, 1996*, 224–52. Ann Arbor: Michigan Slavic Publications.
- Scott, Tatiana. 2003. Cp-topic parameter and Russian WH. Handout for LSA Annual Meeting 2003, Atlanta, GA.
- Steedman, Mark. 2000. Information structure and the Syntax-Phonology Interface. *Linguistics Inquiry* 31:649–89.

Cooperating constructions in Lai “lexical insertion”

Andreas Kathol

University of California Berkeley

Proceedings of the 10th International Conference on
Head-Driven Phrase Structure Grammar

Michigan State University

Stefan Müller (Editor)

2003

Stanford, CA: CSLI Publications

pages 203–221

Kathol, Andreas. 2003. Cooperating constructions in Lai “lexical insertion”. In Stefan Müller (ed.), *Proceedings of the 10th International Conference on Head-Driven Phrase Structure Grammar, Michigan State University*, 203–221. Stanford, CA: CSLI Publications. DOI: 10.21248/hpsg.2003.12.



Abstract. In this paper we investigate the factors conditioning a morphological alternation on verbal heads in Lai. We show that this alternation eludes a simple characterization and instead exhibits a many-to-many form–function mapping. We will further show that the facts can be given a straightforward analysis in terms of default conditions based on valence and polarity, together with various constructional overrides. Our analysis thus follows recent proposals in HPSG, in particular Malouf (forthcoming), in using a constructional type hierarchy with defaults (“cooperating constructions”) as an alternative to an Optimality Theoretic system of ranked violable constraints.

1 Introduction

From a constraint-based perspective “lexical insertion”, in the typical cases, involves a relatively straightforward matching of lexical requirements and syntactic context. Morphological variation on heads ordinarily means that a particular form of the head can only occur in a particular syntactic environment. For instance, the morphological distinction between an active and a passive form of some lexeme can be viewed in terms of different ways in which the lexeme determines properties of its syntactic environment, specifically in terms of number and morphology (case) of its dependents.¹

Even in English, however, there exist cases in which the interplay between morphological form and syntactic context arguably works in the opposite direction, i.e., where the constructional context determines the morphology of some head. A prominent example is the distribution of the negated 1st singular form of *be*.² In the standard variety, this expression occurs as *aren’t* in inverted clauses (1a) while no form is available to occur in non-inverted contexts (1a):

- (1) a. **Aren’t** I a clever person?
b. *I **aren’t** a clever person.

Such facts are standardly modeled by means of such devices as the head feature *INV*, which allows us to require of 1st singular *aren’t* that it appear only in $[INV +]$ contexts. The feature *INV* is thus a device to connect the lexical form to its constructional environment of occurrence.

In this paper, we investigate the interplay of morphological form and constructional context in Lai (also known as Hakha Chin), a Tibeto-Burman language of the Kuki-Chin/Naga branch spoken mostly in Western Burma, parts of Bangladesh, and India’s Mizoram province. We will show that the constructional determination

¹Of course, from a constraint-based perspective, the causal connotations of such notions are meaningless at the level of determining well-formedness via constraint satisfaction. Nevertheless, they are useful in reasoning about grammar design.

²We assume here, with Zwicky & Pullum (1983), that “contracted” negated forms are part of the inflectional paradigm of auxiliaries in English.

of verbal head morphology, which appears fairly unusual in English, is ubiquitous in the language and strongly suggests an analysis along Malouf’s (forthcoming) notion of “cooperating constructions.”

2 Stem alternations in Lai

Most verbs in Lai exhibit an alternation in stem morphology, which is illustrated in (2) for the verb *'it/i'* (‘sleep’).

- (2) a. Mangkio 'a-'**it**.
 Mangkio 3SG-sleep.I
 ‘Mangkio slept/is sleeping.’
- b. Mangkio 'a-'**i'** tsa-'a', ...
 Mangkio 3SG-sleep.II because
 ‘Because Mangkio slept/was sleeping, ... ’

In the example in (2a), the verb occurs in what we will call its “stem I” variant (*'it*) whereas the example in (2b) illustrates this verb in its “stem II” alternative (*'i'*). We now turn to the conditions that govern the distribution of stem I vs. stem II.

3 Conditions on stem choice

3.1 Stem alternation and ergativity

Starting with what we will call the most “unmarked” syntactic environment—i.e., affirmative root declarative clauses—the choice of stem in Lai is linked in a fairly direct way to argument structure. The basic pattern is that of intransitive verbs of all kinds exhibiting stem I morphology (3), whereas transitive verbs are realized morphologically as stem II, (4).

- (3) a. Mangkio 'a-'**it**.
 Mangkio 3SG-sleep.I
 ‘Mangkio slept/is sleeping.’
- b. *Mangkio 'a-'**i'**.
 Mangkio 3SG-sleep.II
- (4) a. Mangkio ni' vok 'a-**tsook**.
 Mangkio ERG pig 3SG-buy.II
 ‘Mangkio is buying/bought a pig.’
- b. *Mangkio ni' vok 'a-**tsoo**.
 Mangkio ERG pig 3SG-buy.I

Transitive verbs occurring in the unmarked environment obligatorily require that the subject be accompanied by the ergative marker *ni*'. Absence of this marker in the context of stem II morphology leads to unacceptability, as is demonstrated in (5).

- (5) *Mangkio vok 'a-**tsook**.
Mangkio pig 3SG-buy.II

Importantly, the notion of transitivity governing stem choice is quite directly tied to the existence of a second *nominal* dependent, in addition to the subject. That is, the presence of other types of dependents, such as oblique locational, directional, or temporal modifiers, does not cause a notionally intransitive verb to occur with stem II morphology, cf. (6):

- (6) Nizán 'a' khwa tshung 'a' 'a-tlii/*tliik.
yesterday LOC village inside LOC 3SG-run.I/run.II
'Yesterday he ran into the village.'

As we will see below, however, there are other constraints on stem determination (specifically in nonsubject questions and relative clauses) which are sensitive to the presence of *any* nonsubject dependent, not just nominal ones.

3.2 Non-Ergative construction

The straightforward correlation between stem choice and transitivity status established so far faces an apparent counterexample. Notionally transitive predicates may also occur with stem I, in which case the ergative marker is obligatorily absent:

- (7) a. Mangkio vok 'a-**tsoo**.
Mangkio pig 3SG-buy.I
'Mangkio bought a pig.'
b. *Mangkio **ni**' vok 'a-**tsoo**.
Mangkio ERG pig 3SG-buy.I

Following Peterson (1998:88) we will refer to such examples as “*non-ergative constructions*”. This construction type raises the question of how it is different from transitive verbs occurring in the ordinary ergative construction. *Prima facie* there does not appear to be a clear truth-conditional meaning difference between the two.³ In order to understand how the non-ergative construction differs from the

³Peterson (1998:88) suggests that transitive verbs occurring in the non-ergative construction require that the event not be completed, as for instance in the case of future tense. Thus, the distinction would reduce to an aspectual difference. Similarly, Henderson (1965:84) suggests that verbs occurring in “inconclusive sentences” in the closely related language Tiddim Chin exhibit “subjunctive mood”, i.e., stem II, while “conclusive” ones display “indicative mood”, i.e., stem I. However, the example in (7a) shows that lack of completion cannot be the determining factor since the non-ergative construction is indeed compatible with a past interpretation of the predicate.

ergative one, it is necessary to consider the discourse potential of each construction. If the context is such that a nonsubject dependent is topical, only the ergative construction is possible, as is shown in (8).

- (8) a. Vok zayda' 'a-tsàng?
 pig what 3SG-become
 'What is happening to the pig?'
 b. Mangkio_{nontopic} ni' 'a-tsook.
 Mangkio ERG 3SG-buy.II
 'Mangkio bought [it].'
 c. *Mangkio 'a-tsoo.
 Mangkio 3SG-buy.I

Topics may in fact be overtly marked by means of the discourse particle *khaa*; thus in the presence of an ergative marked subject, the object may be accompanied by *khaa*, as shown in (9):

- (9) Mangkio ni' vok **khaa** 'a-tsook.
 Mangkio ERG pig TOP 3SG-buy.II
 'Mangkio bought a/the pig.'

On the other hand, in a context in which the subject of a sentence is understood as the topic of the preceding discourse, as in (10a), only the non-ergative construction is acceptable, as is illustrated in (10c).

- (10) a. Mangkio ta'?'
 Mangkio Q
 'What about Mangkio?'
 b. Mangkio_{topic} vok 'a-tsoo.
 Mangkio pig 3SG-buy.I
 'Mangkio bought a pig.'
 c. *Mangkio ni' vok 'a-tsook.
 Mangkio ERG pig 3SG-buy.II

Further support for the topic status of the subject in such cases comes from the fact that subjects may optionally occur with the topic marker *khaa*, as illustrated in (11):

- (11) Mangkio khaa vok 'a-tsoo.
 Mangkio TOP pig 3SG-buy.I
 'Mangkio bought a pig.'

The different discourse potential of subjects in non-ergative constructions is highly reminiscent of some of the effects displayed by antipassives in the world's languages. For instance, Cooreman (1994:68) argues that by backgrounding an O-argument, an antipassive allows for a lower degree of "referential continuity" for

the O-argument, which in turn makes the subject better suited to be linked to the discourse topic. Conversely, in an ergative construction, it is the O-argument which by default is linked to the discourse topic.

The analysis of non-ergative constructions as antipassive makes a number of interesting predictions that are borne out in Lai grammar.⁴ As Peterson & VanBik (2001) point out, in conjoined sentences of the kind shown in (12), the interpretation of the pronominal element in the second clause depends on the ergative status of the preceding clause. If the latter is ergative (12a), the O-argument is topical in providing the referent for the pronominal object marker on the verb. Conversely, if the latter is non-ergative (12b), the subject is topical in providing the referent for the pronominal object marker:

- (12) a. 'Aarpii ni' tii 'a-tiit 'ii ka-hmu'.
 hen ERG egg 3SG-laid.II CONJ 1SG-see.II
 'The hen laid an egg and I saw it (the egg/*the hen).'
- b. 'Aarpii tii 'a-tii 'ii ka-hmu'.
 hen egg 3SG-laid.I CONJ 1SG-see.II
 'The hen laid an egg and I saw her (the hen/*the egg).'

As Peterson & VanBik (2001) further show, the difference in topicality is correlated with the construal in conjunction-reduction constructions of the kind familiar from Dixon's (1972) study of Dyirbal. Thus, in the ergative construction in (13a), the missing element in the second clause is construed with the O-element of the preceding clause, whereas in (13b), the non-ergative construction makes it possible for the subject of the first clause to identify the unexpressed argument of the second clause:

- (13) a. Lawthlawpaa ni' ka-faa 'a-siik 'ii '-kal.
 farmer ERG 1SG.POSS-child 'a-scold.II and.then 3SG-go.I
 'The farmer scolded my child and then he (*the farmer/the child) left.'
- b. Lawthlawpaa ka-faa 'a-sii 'ii '-kal.
 farmer 1SG.POSS-child 'a-scold.I and.then 3SG-go.I
 'The farmer scolded my child and then he (the farmer/*the child) left.'

In the terminology of Dixon (1979), we can say that the non-ergative construction feeds an S/O pivot in conjunction reduction constructions. We now turn to another example of such pivot-feeding behavior in the case of relative clause formation.

3.3 Ergativity and relative clause formation

If non-ergative constructions are considered antipassives, we also obtain a rather straightforward account of relative clauses.⁵ Relative clauses in Lai are formed

⁴The idea of analyzing non-ergative constructions as instances of antipassive is first made in passing by Peterson (1998:88,n.3).

⁵An analysis along these lines was first suggested to us by David Perlmutter (p.c.).

by means of a relative marker such as *mii* which follows the clause-final verb. The noun to be relativized may either occur inside the relative clause or immediately following the relative marker. In the first case we obtain an internally headed relative clause (IHRC), whereas the second is an externally headed relative clause (EHRC).⁶ For expository reasons, we only discuss internally headed relative clauses here.

In IHRC constructions the noun whose denotation is restricted by the relative clause also occurs within the clause providing that restriction. The major division in the syntax of IHRC is whether a subject or some other dependent is relativized. In the former case, the verb obligatorily occurs with stem I, both for intransitive (14a) and transitive (14b) predicates:

- (14) a. [lawthlawpaa truang 'a' 'a-**'it/*'i'**] mii
 farmer floor LOC 3SG-sleep.I/sleep.II REL
 'the farmer who slept on the floor'
- b. ['uitsow lawthlawpaa 'a-**that/*tha'**] mii
 dog farmer 3SG-kill.I/kill.II REL
 'the dog that killed the farmer'

Subjects of transitive predicates that are relativized cannot be accompanied by the ergative marker, hence the example in (15) is unacceptable:

- (15) *['uitsow ni' lawthlawpaa 'a-**that**] mii
 dog ERG farmer 3SG-kill.I REL

The opposite situation holds whenever a nonsubject dependent is relativized. Only stem II is possible now, as shown in (16):

- (16) [lawthlawpaa ni' 'uitsow 'a-**tha'/*that**] mii
 farmer ERG dog 3SG-kill.II/kill.I REL
 'the dog that the farmer killed'

These facts fall into place if we assume that relativization is constrained by an S/O pivot; a situation that is familiar from relative clause formation, for instance in Dyirbal (Dixon 1972), Yidin^y (Dixon 1977), Greenlandic Eskimo (Woodbury 1977), and Mayan languages (England 1983). In the parlance of Cooreman (1994:74), it appears that the antipassive construction has been “co-opted” for strictly structural purposes. Given that the primary function of the non-ergative construction in Lai appears to be information structural by assigning topic status to the subject, it seems natural for the pivot in relative clause formation to include the topical elements, i.e., derived S, and O.

The data surveyed so far show that ergative/non-ergative status lies at the heart of the stem I vs. II distinction in Lai. If we consider the non-ergative construction

⁶The syntax of internally and externally headed relative clauses in Lai is further investigated in Kathol & VanBik 1999 and Kathol 2001.

an instance of antipassive, that is, as grammatically intransitive, a number of facts including relative clauses and topic-chaining constructions can be explained rather straightforwardly. However, stem choice is not wholly predictable on the basis of valence alone. A complicating factor is negation, to which we turn next.

3.4 Negation

Negation at the clausal level in Lai is expressed by means of the particle *low*. As the examples in (17) show, in negative environments of this kind, only stem I is permissible for both intransitive and transitive verbs:⁷

- (17) a. Mangkio 'a-**tlɪi**/***tlɪik** low.
 Mangkio 3SG-run.I/run.II NEG
 'Mangkio did not run.'
- b. Mangkio ni' vok 'a-**tsoo**/***tsook** low.
 Mangkio ERG pig 3SG-buy.I/buy.II NEG
 'Mangkio did not buy a/the pig.'

It is important to note that the occurrence of stem I with notionally transitive predicates in negated contexts is of a rather different nature than what we saw earlier in the non-ergative construction. While the non-ergative case never allowed for the subject to be marked ergatively, this is not so for negated clauses. As is illustrated in (17b), stem I is fully compatible with the ergative marker *ni'*. This strongly argues against analyzing stem I in negated clauses as another instance of antipassive. Supporting evidence for this conclusion comes from the observation that the presence/absence of the ergative marker is regulated by essentially the same conditions on the (non)topichood of the subject that we saw earlier in (10) and (16) as illustrated in (18–19):

- (18) a. Vok zayda' 'a-tsàng?
 pig what 3SG-become
 'What about the pig?'
- b. Mangkio_{nontopic} ni' 'a-**tsoo** low.
 Mangkio ERG 3SG-buy.I NEG
 'Mangkio did not buy [it].'
- c. *Mangkio 'a-**tsoo** low.
 Mangkio 3SG-buy.I NEG
- (19) a. Mangkio zayda' 'a-tsàng?
 Mangkio what 3SG-become
 'What about Mangkio?'

⁷For the sake of brevity we only give translations with past tense interpretation whenever the future tense marker *laay* is absent. However, a nonpast interpretation is equally possible.

- b. Mangkio_{topic} vok 'a-**tsoo** low.
 Mangkio pig 3SG-buy.I NEG
 'Mangkio did not buy a pig.'
- c. *Mangkio ni' vok 'a-**tsook** low.
 Mangkio ERG pig 3SG-buy.II NEG

It therefore appears that the uniform occurrence as stem I “masks” the two modes of expression of transitive predicates. Hence the only diagnostic for the non-ergative construction in negated clauses is the absence of the ergative marker, but not the stem choice.

We next turn to conditions on determination involving constructional environments which in sense are “larger” than the verbal predicate and its polarity. Since the fact that the constraints are tied to properties of whole clauses, rather than individual elements, we will refer to these constraints as “construction-based”⁸

3.5 Construction-based constraints

Imperatives. Subjectless constructions with the imperative marker *tua*' require the presence of stem I. As before, the transitive/intransitive distinction does not play a role, cf. (20).

- (20) a. 'It/*i' tua'
 sleep.I/sleep.II IMP
 'Sleep!'
- b. Tii **dĩng/*dín** tua'
 water drink.I/drink.II IMP
 'Drink the water!'

To a certain degree, the uniform occurrence of stem I is not surprising here if the addressee of imperative statements is inherently construed as a topic, hence requiring transitive predicates to occur in the non-ergative construction with stem I.

Polar interrogatives. These also require that the verbs occur with stem I morphology. This is illustrated in (21).

- (21) a. Mangkio 'a-**tlii/*tliik** ma?
 Mangkio 3SG-run.I/run.II Q
 'Did Mangkio run?'
- b. Mangkio ni' vok 'a-**tsoo/*tsook** ma?
 Mangkio ERG pig 3SG-buy.I/buy.II Q
 'Did Mangkio buy a pig?'

⁸This is a slight abuse of terminology given that Construction Grammarians have always insisted on the ontological relatedness of words and larger units of syntactic organization as involving irreducible pairings of sound and meaning.

The occurrence of stem I is orthogonal to the ergative vs. non-ergative realization of notional transitive predicates. For instance, the following example, the object of the continuation question in (22b) is construed as the discourse topic. Due to its nontopic status, the subject obligatorily occurs with the ergative marker, despite the presence of stem I:

- (22) a. Vok ta'?'
 pig Q
 'What about the pig?'
 b. Mangkio ni' 'a-tsoo ma?
 Mangkio ERG 3SG-buy.I Q
 'Did Mangkio buy it?'
 c. *Mangkio 'a-tsoo ma?
 Mangkio 3SG-buy.I Q

If the subject within the polar question is understood as topical, as in (23), the result is the exact opposite. Here, no ergative marker may be present, as shown in (23c).⁹

- (23) a. Mangkio ta'?'
 Mangkio Q
 'What about Mangkio?'
 b. Mangkio vok 'a-tsoo ma?
 Mangkio pig 3SG-buy.I Q
 'Did Mangkio buy a/the pig?'
 c. *Mangkio ni' vok 'a-tsoo ma?
 Mangkio ERG pig 3SG-buy.I Q

Antecedents of conditionals. The last syntactic environment triggering stem I morphology throughout is antecedents of conditionals, as illustrated in (24).

- (24) a. Mangkio 'it/*i' koo, ...
 Mangkio sleep.I/sleep.II if
 'If Mangkio slept, ...'
 b. Mangkio ni' vok tsoo/*tsook koo, ...
 Mangkio ERG pig buy.I/buy.II if
 'If Mangkio bought a pig, ...'

This environment is particularly interesting given that (adverbial) subordinate clauses in general in fact display the opposite behavior, i.e., they lead to the uniform choice of stem II morphology, as discussed in the next section.

⁹Examples such as (23b) are of course slightly artificial in the sense that an overt repetition of a topic gives rise to stylistic awkwardness. Nevertheless, this awkwardness is in clear contrast to the type of unacceptability that arises from the infelicitous use of the ergative marker in (23c).

3.5.1 Uniform stem II environments

Stem neutralizations may also occur in the opposite direction, i.e., in favor of stem II. There are two main environments in which have this property.

Adverbial subordinate clauses. The first such set of environments are (adverbial) subordinate clauses of various kinds (cf. also (2b) above). This is illustrated here with the temporal adverbial clauses in (25).

- (25) a. Mangkio 'a-'i'/*'it tik-'a', ...
 Mangkio 3SG-sleep.II/sleep.I when
 'When Mangkio slept, ...'
 b. Mangkio ni' vok 'a-tsook/*tsoo tik-'a', ...
 Mangkio ERG pig 3SG-buy.II/buy.I when
 'When Mangkio bought the pig, ...'

The uniform occurrence of stem II in subordinate adverbial clauses again suggests that the morphology is no longer indicative of whether a notional transitive predicate occurs in the ergative or non-ergative construction. This means that subjects of transitive adverbial subordinate clauses should occur with or without ergative marker depending on whether they have nontopic or topic status, respectively. This is precisely what we find. As Peterson & VanBik (2001) observe, the presence/absence of the ergative marker has precisely the same effect on possible anaphoric dependencies that was noted earlier in (12). Thus, despite the uniform stem II morphology, only phrases with absolutive status are topical and thus provide eligible antecedents for the understood object pronoun in (26).

- (26) a. [Lawthlawpaa ni' ka-zaal 'a-ba' tik-'a'] ka-hmu'.
 farmer ERG 1SG.POSS-bag 'a-hang.II when 1SG-see.II
 'When the farmer hung up my bag, I saw it (the bag/*the farmer).'
 b. [Lawthlawpaa ka-zaal 'a-ba' tik-'a'] ka-hmu'.
 farmer 1SG.POSS-bag 'a-hang.II when 1SG-see.II
 'When the farmer hung up my bag, I saw him (the farmer/*the bag).'

There is some evidence that uniform choice of stem II is a constructional feature of grammatically subordinate environments in general. Thus, certain constructions that have nonfinite complement clause equivalents in languages with finite vs. nonfinite inflectional morphology also call for stem II in Lai. One instance is complements of verbs of perception such as *hnuí/hmu* ('see'), as shown in (27):

- (27) a. Lawthlawpaa 'a-'i'/*'it ka-hmu'.
 farmer 3SG-sleep.II/sleep.I 1SG-see.II
 'I saw the farmer sleep.'
 b. Lawthlawpaa vok 'a-tsook/*tsoo ka-hmu'.
 farmer pig 3SG-buy.II/buy.I 1SG-see.II
 'I saw the farmer buy a pig'

Subordinate environments of this kind are typically closely connected to nominalizations. The fact that such constructions exhibit stem II morphology thus may lend support to the idea advanced by Peterson (1998:88) that the use of stem II in ergative constructions is historically derived via reanalysis from a nominalizing function.¹⁰

Nonsubject content questions. Constituent questions involving nonsubject dependents also require uniformity of verbal morphology, regardless of the transitive/ergative status of the verb involved. Neutralization to stem II applies in the case of argument questions, as in (28), as well as in adverbial questions as in (29).

- (28) a. Mangkio ni' zeí da' 'a-**dín**/***dìng**?
 Mangkio ERG what 3SG-drink.II/drink.I
 'What did Mangkio drink?'
 b. Mangkio ni' zeí vok da' 'a-**tsook**/***tsoo**?
 Mangkio ERG which pig 3SG-buy.II/buy.I
 'Which pig did Mangkio buy?'
- (29) a. Zeí tik 'a' da' Mangkio 'a-**'i**/***'it**?
 when Mangkio 3SG-sleep.II/sleep.I
 'When did Mangkio sleep?'
 b. Zeí tik 'a' da' Mangkio ni' vok 'a-**tsook**/***tsoo**?
 when Mangkio ERG pig 3SG-buy.II/buy.I
 'When did Mangkio buy a/the pig?'

It is worth pointing out that stem choice is not fully predictable in the case of adverbial dependents of intransitive predicates, cf. (29a) above. That is, the occurrence of stem II is not patterned on an independently existing construction that licenses stem II occurrences of intransitive predicates.¹¹ For that reason, we will regard nonsubject questions as a separate construction type for the purposes of stem determination.¹²

3.5.2 Variable environments, again

Subject questions. While stem choice is uniform in nonsubject questions, it is variable in subject questions. The latter environments are thus similar to declarative affirmative root clauses and relative clauses in not imposing a uniform constraint on stem choice. Moreover, the conditions on stem choice appear very

¹⁰See also Comrie (1978:376) on this point.

¹¹The same holds also for relativized adverbial dependents, which uniformly require stem II, independent of the head valence.

¹²As Jim Blevins (p.c.) has pointed out to us, nonsubject questions can be seen as a natural class if they are all given a dislocation analysis. However, given that some nonsubject questions involve in-situ orders (cf. (28)), it is not clear to us how viable such an approach ultimately would be.

closely tied to transitivity/ergativity. Subject questions formed from intransitive predicates exhibit stem I morphology, as is shown in (30):

- (30) 'a-how da' 'a-**it**/***i**'?
 who 3SG-sleep.I/sleep.II
 'Who slept?'

Subject questions formed from transitive predicates in principle allow for occurrence of either stem I or II. In the first case, we again have an instance of a non-ergative construction. Subject questions of this kind tend to occur if the subject has already been introduced in the previous discourse and hence bears some degree of topicality. For instance in the following pair of sentences, the question in (31b) serves to obtain a more detailed account of a particular person among the previously mentioned people—specifically the one who helped Mangkio.

- (31) a. Mii-zey-moo ni' Nihu le Manngkio 'an-bom'-hnaa.
 some people ERG Nihu and Mangkio 3PL-help.II-3PL
 'Some people helped Nihu and Mangkio.'
 b. 'a-how da' Manngkio 'a-**bóom**?
 who Mangkio 3SG-help.I
 'Who (among them) helped Mangkio?'

Conversely, it is also possible to ask a subject question in a context in which an element other than the subject is high in topic status. In the example in (32), Mangkio is explicitly introduced as the topic of discourse leading up to the subject question in (32b). As a result, the question occurs with stem II and ergative marker:

- (32) a. Mangkio ta'?
 Mangkio Q
 'What about Mangkio?'
 b. 'a-how ni' da' (Manngkio) 'a-**bom**'?
 who Mangkio 3SG-help.II
 'Who helped Mangkio?'

The above examples show that in the case of subject questions, the status of the questioned phrase as a focus must be seen as decoupled from the issue of which element is construed as topical with respect to the distinction between ergative/non-ergative constructions.

3.5.3 Summary

The findings so far can be summarized in the schematic representation in (33). Here, the different syntactic environments are listed, together with the realization possibilities for morphology and the ergative marker for intransitive and transitive predicates.

(33)

	intransitive	transitive	
		non-ergative	ergative
<i>unmarked</i>	I	I	II, ni'
<i>subj Q</i>	I	I	II, ni'
<i>subj. Rel.</i>	I	I	N/A
<i>imperative</i>	I	I	N/A(?)
<i>negation</i>	I	I	I, ni'
<i>polarity Q</i>	I	I	I, ni'
<i>if-clause</i>	I	I	I, ni'
<i>nonsubj Q</i>	II	II	II, ni'
<i>nonsubj. Rel.</i>	II	N/A	II, ni'
<i>adv. subord</i>	II	II	II, ni'

Whenever a row contains a “N/A” entry, it means that the construction in question is not possible in that syntactic environment. This is clearly the case, as we argued above, for subject relative clauses in that an A-argument would not fit the S/O pivot operative in relativization. We similarly suggested that the uniform choice of stem I in imperative constructions could be seen as due to the obligatory topic status of the understood subject. Conversely, the unavailability of the non-ergative construction in nonsubject relative clauses can be explained along very similar lines. This means, however, that there is a residue of environments—in particular polarity questions, negation and adverbial clauses—in which stem choice is not (synchronically) connected to ergativity. These are thus environments where morphological expression is entirely conditioned by the constructional environment.

4 Stem determination via cooperating constructions

In this section we will present an analysis of Lai stem choice which mirrors the presentation of the data above. That is, we will assume that valence and polarity give rise to default constraints which can be “overridden” in particular constructional environments. These default constraints are based on the hierarchy of constructions shown in (34). The basic idea is that the properties of constructions of interest arise from a cross-classification of valence properties (i.e., ergativity status) and polarity (i.e., whether or not the predicate is negated).

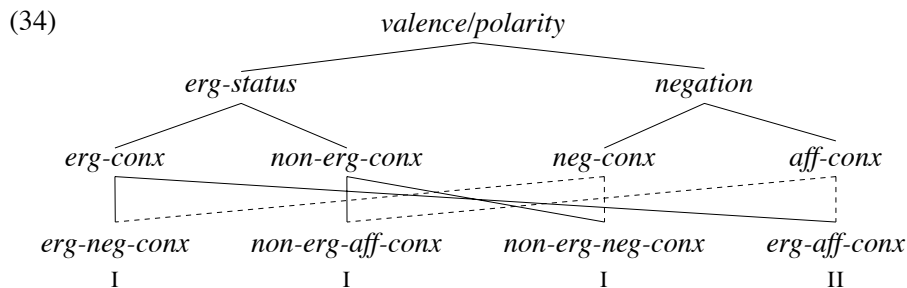

Also listed in the hierarchy is the stem choice associated with each of the four constructional types. Since only one of the four constructions (*erg-aff-conx*) is associated with stem II, it is natural to assume that within the hierarchy in (34), I is the default value for VFORM of the topmost type (*valence/polarity*), as implemented by the constraint in (35a). Ergative affirmative contexts are associated with a conflicting constraint, as shown in (35b) and thus override the stem choice specification inherited from their supertype.

- (35) a. *valence/polarity* \rightarrow $\left[\dots | \text{VFORM } /i \right]$
 b. *erg-aff-conx* \rightarrow $\left[\dots | \text{VFORM } /ii \right]$

The reason why the constraint in (35b) is also soft will become clear soon, when we consider how these constraints interact with clause-level constructional constraints.

It may be helpful to turn our attention to the (partial) description of a few lexical items. As is shown in (35–36), the lexicon matches particular morphological forms with the syntactic status of that form as with stem I or stem II for both intransitive and transitive verbs.

- (36) a. *'it* ‘sleep’
 $\left[\begin{array}{l} \dots | \text{ARG-ST } \langle \text{NP} \rangle \\ \dots | \text{VFORM } i \end{array} \right]$
 b. *'i* ‘sleep’
 $\left[\begin{array}{l} \dots | \text{ARG-ST } \langle \text{NP} \rangle \\ \dots | \text{VFORM } ii \end{array} \right]$
- (37) a. *tsoo* ‘buy’
 $\left[\begin{array}{l} \dots | \text{ARG-ST } \langle \text{NP}, \text{NP} \rangle \\ \dots | \text{VFORM } i \end{array} \right]$
 b. *tsook* ‘buy’
 $\left[\begin{array}{l} \dots | \text{ARG-ST } \langle \text{NP}, \text{NP} \rangle \\ \dots | \text{VFORM } ii \end{array} \right]$

What is not determined lexically, however, is information on the case marking of the various verbal dependents. As a result, the case marking properties can be determined directly by the construction that a given verb occurs in, as shown in (38)

- (38) a. *valence/polarity* \rightarrow $\left[\dots | \text{ARG-ST } / \langle \text{NP}[\text{ABS}] \rangle \oplus \text{listof}(\neg \text{NP}[\text{ERG}]) \right]$
 b. *erg-conx* \rightarrow $\left[\dots | \text{ARG-ST } \langle \text{NP}[\text{ERG}], \text{NP} \rangle \right]$

For the base cases we considered above, this means that, by default, a verb occurring in any subtype of the *valence/polarity* Construction, will have an absolutive subject. Ergative constructions, both affirmative and negated, take ergative subjects. As before with the stem form, this state of affairs can be captured naturally by associating a default constraint with the supertype and assuming an overriding constraint for the “exceptional” subtype, that is, ergative constructions. In our analysis, a non-ergative (antipassive) constructions simply arises from a transitive verb occurring within a *non-erg-conx*, whose case marking behavior is inherited from *valence/polarity*.

4.1 Interaction between lexical and constructional information

As the discussion in the preceding sections showed, particular constructional environments override the stem choice constraints imposed by valence and polarity. This raises the issue of this interaction of conflicting constraints is properly implemented. Based on the constructional feature idea (INV) commonly used for the interaction between inversion contexts and choice of copular form in English mentioned above, one possibility would be to decompose each relevant environment as a particular combination of binary feature values. As the example in (39) illustrates, negation in environments that are not adverbial clauses trigger stem I:

$$(39) \quad \left[\begin{array}{l} \text{POLAR} \quad - \\ \text{ADV-CLAUSE} \quad - \\ \text{NEG} \quad + \end{array} \right] \rightarrow \left[\dots \mid \text{VFORM } i \right]$$

The disadvantage of such an approach is that separate binary features are needed to encode each constructional environment, together with a battery of value combinations that define the triggering environments for each value setting. Moreover, these combinations of feature–value pairs obscure the default/override relationships among the various conditions.

The alternative approach pursued here is to use the type system as a repository of constructional possibilities and let stem determination be driven by the interplay between “soft” default constraints and “hard” non-default constraints.

Beginning with polar interrogatives and adverbial subordinate clauses, the constraints in (40) straightforwardly capture the fact that the former always exhibit stem I morphology while the latter always contain a stem II predicate.

$$(40) \quad \text{a. } \textit{polar} \rightarrow \left[\dots \mid \text{VFORM } i \right]$$

$$\quad \text{b. } \textit{adv-subord} \rightarrow \left[\dots \mid \text{VFORM } ii \right]$$

Defined as hard constraints, these will win out over any conditions stemming from the valence/polarity set in (38) above. For instance, a ergative polar question displays stem I morphology because the stem II requirement in (38b) is trumped by the constraint in (40a). The interaction between the various constraints is made possible by the fact that the constructional types in (38b) do not classify verbs, but instead the clausal constructions in which the verbs occur.¹³ If we combine the hierarchy in (34) with a partial hierarchy of additional constructional possibilities, we obtain a multiple inheritance hierarchy which is partially shown in (41). The actual space of constructions (e.g., *decl-erg-neg-conx*) arises as the cross-product

¹³This potentially raises issues having to do with syntactic locality. Note, in particular, that the constraints in (38) make reference to the ARG-ST values of clausal constructions. This is at odds with the wide-spread assumption within HPSG that ARG-ST information is not projected from the lexical level (e.g., Sag *et al.* 2003). The current proposal builds on arguments provided in Kathol 2003 in favor of projecting ARG-ST information. Alternatively, it may be sufficient for the constraints in question to only access subject information, which would be in accordance with recent evidence in favor of projecting subject information to the clause level.

of the *clause-type* and *valence/polarity* leaf types, by virtue of on-line type construction of the kind proposed in Koenig 1999.

(41) **Partial constructional hierarchy**

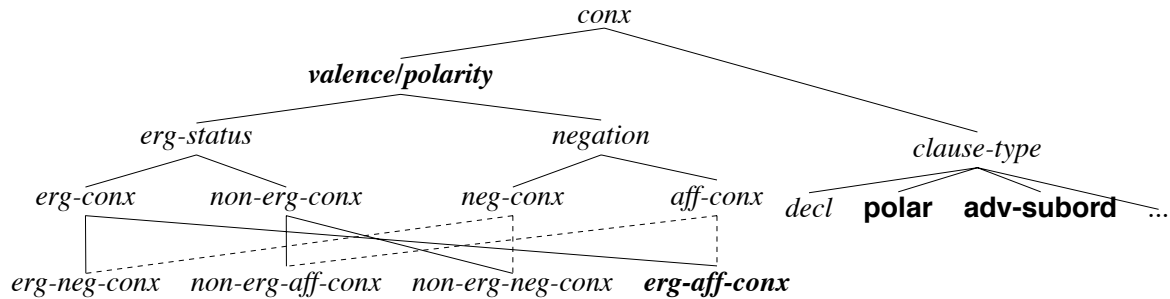

For ease of exposition, the hierarchy in (41) distinguishes graphically type antecedents for **soft constraints** and **hard constraints**. For instance, the stem choice for a *polar-erg-aff-conx* results from the soft constraint associated with *valence/polarity*, which is overridden by the soft constraint originating with *erg-aff-conx*, which in turn is trumped by the inviolable constraint associated with *polar* constructions. It also becomes apparent that declarative clauses do not exhibit any intrinsic stem determination behavior of their own. As a result, the only constraints that are relevant to them are based on valence/polarity properties.

As Malouf (forthcoming) points out, constraints that are organized according to their specificity within a type hierarchy, together with defaults and overrides (which he refers to as “cooperating construction”), make it possible to capture some of the same intuitions that lead to Optimality Theory as a framework for the interaction of violable constraints. One crucial difference, however, is that OT constraints operate at the utterance level itself; that is, these constraints are directly brought to bear to determine the well-formedness of a given utterance candidate, in relation to potentially better suited candidates. In contrast, constraint interaction by means of type hierarchies occurs at the level of grammatical description, i.e., it defines the constructional inventory. As a result, the process of selecting candidates, drawn from a potentially infinite set, is sidestepped altogether.

5 Concluding remarks

The Lai data presented here provide no (convincing) evidence for a simple synchronic form–function relationship between stems and their syntactic/semantic/pragmatic environment of occurrence. Instead, a fully satisfactory account of why the distribution of stems is the way it is will inevitably have to take diachronic factors into account, such as the development of ergativity.

If the proposed analysis of the synchronic facts is on the right track, it suggests that the same set of morphological distinctions on a head may serve a number of different purposes, not only to express intrinsic properties of that head but also

to mark the larger construction within which the lexical element occurs. This is reminiscent of cases in which the morphosyntax of a dependent element is determined nonlocally, in particular with respect to case marking. For instance, Börjars & Vincent (2000) cite data such as (42) from Classical Armenian showing that it is possible for phrases not to occur with the locally appropriate case (genitive), but rather take on the case marking of the larger containing construction (ablative).

- (42) a. i knoj-ê t'agawor-i-n
 by wife-ABL.SG king-GEN.SG-DEF
 'by the king's wife'
- b. i knoj-ê t'agawor-ē-n
 by wife-ABL.SG king-ABL.SG-DEF
 'by the king's wife'

Malouf's (2000) approach to such phenomena suggests that there is no strict limit to the structural distance between the triggering head and the exceptionally marked dependent. This fact sets such cases apart from the situation considered here, which is strictly confined to the domain of a single clause. We will leave it for further research to determine whether, despite appearances, nonlocal determination of morphosyntactic properties of dependent has enough properties in common with nonlocal effects on head morphology to warrant a more unified treatment than is currently available.

Acknowledgments

Many thanks go to my Lai language consultant and frequent collaborator Ken Van-Bik. I am also grateful for useful comments and discussion at the conference as well as the attendants of the Stanford Syntax Workshop, April, 2003.

References

- BÖRJARS, KERSTI, & NIGEL VINCENT. 2000. Multiple case and the 'wimpiness' of morphology. In *Argument Realization*, ed. by Miriam Butt & Tracy Holmway King, 15–40. Stanford: CSLI Publications.
- COMRIE, BERNHARD. 1978. Ergativity. In *Syntactic Typology*, ed. by W. P. Lehman, 329–394. Austin: University of Texas Press.
- COOREMAN, ANN. 1994. A functional typology of antipassives. In *Voice: Form and Function*, ed. by Barbara Fox & Paul Hopper, 49–88. Amsterdam/Philadelphia: John Benjamins.
- DIXON, ROBERT M. W. 1972. *The Dyirbal Language of North Queensland*. Cambridge: Cambridge University Press.

- 1977. *A Grammar of Yidinʷ*. Cambridge: Cambridge University Press.
- 1979. Ergativity. *Language* 55.59–138.
- ENGLAND, NORA C. 1983. Ergativity in Mamean (Mayan) languages. *International Journal of American Linguistics* 49.1–19.
- HENDERSON, EUGÉNIE. 1965. *Tiddim Chin: A Descriptive Analysis of Two Texts*. Oxford: Oxford University Press.
- KATHOL, ANDREAS. 2001. The morphosyntax of Lai relative clauses. In *Grammatical interfaces in HPSG*, ed. by Ronnie Cann, Claire Grover, & Phillip Miller, 137–152. Stanford, CA: CSLI Publications.
- . 2003. Case assignment in fronted partial VPs: an argument-sharing analysis. In *Verb Clusters in Dutch and German*, ed. by Pieter Seuren & Gerard Kempen, Current Issues in Linguistic Theory, 151–183. Amsterdam/Philadelphia: John Benjamins.
- , & KENNETH VANBIK. 1999. Morphology-syntax interface in Lai relative clauses. In *Proceedings of the 29th Annual Meeting of the North Eastern Linguistic Society*, ed. by Pius Tamanji, Masako Hirokami, & Nancy Hall, 427–441, University of Massachusetts, Amherst. GLSA.
- KOENIG, JEAN-PIERRE. 1999. *Lexical Relations*. Stanford: CSLI Publications.
- MALOUF, ROBERT. 2000. A head-driven account of long-distance case assignment. In *Grammatical Interfaces in HPSG*, ed. by Ronnie Cann, Claire Grover, & Philip Miller, 201–214. Stanford, CA: CSLI Publications.
- . forthcoming. Cooperating constructions. In *Mismatch: Form-function Incongruity and the Architecture of Grammar*, ed. by Elaine Francis & Laura Michaelis. Stanford, CA: CSLI Publications.
- PETERSON, DAVID. 1998. The morphosyntax of transitivity in Lai. In *Linguistics of the Tibeto-Burman Area*, ed. by James Matisoff, volume 21.1, 87–153. Berkeley, CA: University of California, Berkeley.
- , & KENNETH VANBIK. 2001. Interclausal ergativity in Lai. Talk given at the Workshop on Tibeto-Burman languages, UC Santa Barbara, 29 July, 2001.
- SAG, IVAN A., THOMAS WASOW, & EMILY BENDER. 2003. *Syntactic Theory: A Formal Introduction (2nd Edition)*. Stanford: CSLI Publications.
- WOODBURY, ANTHONY. 1977. Greenlandic Eskimo, ergativity, and Relational Grammar. In *Grammatical Relations*, ed. by Peter Cole & Jerry Sadock, 251–269. New York: Academic Press.
- ZWICKY, ARNOLD, & GEOFFREY PULLUM. 1983. Cliticization vs. inflection: English *n't*. *Language* 59.502–513.

Semantically transparent linking in HPSG

Jean-Pierre Koenig 

University at Buffalo, SUNY

Anthony Davis 

University at Buffalo, SUNY

Proceedings of the 10th International Conference on
Head-Driven Phrase Structure Grammar

Michigan State University

Stefan Müller (Editor)

2003

Stanford, CA: CSLI Publications

pages 222–235

Koenig, Jean-Pierre & Anthony Davis. 2003. Semantically transparent linking in HPSG. In Stefan Müller (ed.), *Proceedings of the 10th International Conference on Head-Driven Phrase Structure Grammar, Michigan State University*, 222–235. Stanford, CA: CSLI Publications. DOI: 10.21248/hpsg.2003.13. 

Abstract

Most researchers now agree that subcategorization correlates significantly with semantics. But this semantic component of linking has proved elusive. Most, if not all, theories of linking have, in practice, resorted to constructs that are syntactic diacritics. We show in this paper that the implicit syntactic diacritics that plague the basic linking constraints posited in at least some of these theories can be eliminated, provided that (i) the metalanguage in which linguistic constraints are written allows for true implicational statements; (ii) one is willing to slightly increase the number of linking constraints. We focus in particular on the linking theory presented in Davis and Koenig 2000, Davis 2001, and Koenig and Davis 2000, but we maintain that our arguments apply, *mutatis mutandis*, to many other linking theories. We note some of the consequences of this view of linking, including: linking constraints are stated in terms of semantically natural classes of situations, a single entailment of a verb's argument is sufficient to determine its linking, and interaction among linking constraints restricts the range of possible lexical items.

Most researchers now agree that subcategorization correlates significantly with semantics (see, among others, Foley and Van Valin (1984), Pinker (1989), Jackendoff (1990), Levin (1993), Goldberg (1995), Wechsler (1995b), Davis and Koenig (2000b)). To put it in motto form, knowing the meaning of a verb is to a large extent knowing its context of occurrence. But this semantic component of linking has proved elusive. Most, if not all, theories of linking have, in practice, resorted to constructs that are syntactic diacritics. We show in this paper that the implicit syntactic diacritics that plague the basic linking constraints posited in at least some of these various theories can be eliminated, provided that (i) the metalanguage in which linguistic constraints are written allows for true implicational statements; (ii) one is willing to slightly increase the number of linking constraints. Because of space considerations, we focus in particular on the linking theory presented in Davis and Koenig (2000b), Davis (2001), and Koenig and Davis (2001). But we believe our arguments apply, *mutatis mutandis*, to many other linking theories.

1 Syntactic diacritics in semantically-based linking theories

We first briefly present the approach to linking in HPSG described in Davis and Koenig (2000) and Davis (2001). This linking theory is based on three crucial ideas: (1) A multiple inheritance hierarchy of semantic relations; (2) a multiple inheritance hierarchy of predicator types defined by how they link attribute values within their CONTENT to members of the ARG-ST list (more precisely, to the situational nucleus of their CONTENT); (3) a metatheoretical constraint on the relationship between the hierarchy of semantic relations and the hierarchy of predicator types.

[†]We thank Detmar Meurers for discussing some of the issues raised in this paper. All remaining errors are solely ours.

Consider how this theory accounts for the linking of arguments displayed in the following simple transitive sentence.

(1) Sandy moved the ball.

The fact that, for all English transitive verbs that denote causes changing the states of entities, the cause is realized as the subject of its active form, and the entity changing state is realized as the direct object, is modeled through the interaction of three constraints. First, the CONTENT of *move* includes a semantic relation which is a subtype of both *act-rel* and *und-rel*. This is illustrated in figure 1 where lines between nodes labelling semantic relations indicate a subtype-supertype relation. Such a semantic hierarchy, which encodes the (linguistically relevant) relations between categories of situations, helps restrict the grammatical constraints on the realization of semantic arguments to the proper semantically-defined class of verbs.

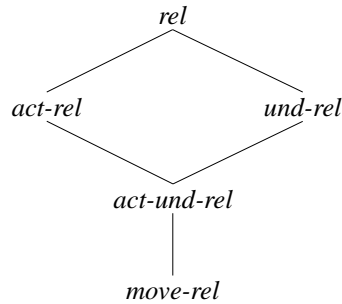

Figure 1: A portion of the semantic relations hierarchy

Second, *move* is a subtype of the type *act-pred* and *und-pred* which require the values of their ACTOR and UNDERGOER attributes to be identical to the values of the CONTENT attribute of the first and second members of the ARG-ST of the verb, respectively, as shown in Figure 2.

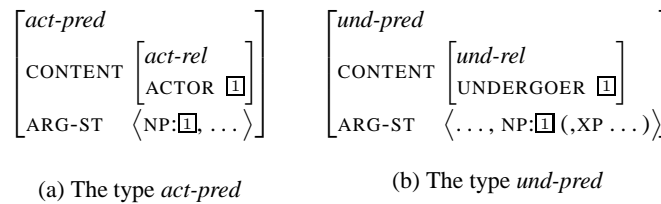

Figure 2: The *act-pred* and *und-pred* linking classes

Third, the metatheoretical constraint on the relationship between the hierarchy of semantic relations and the hierarchy of predicator types stated in (2) ensures that *because* the semantic relation of *move* is a subtype of *act-und-rel*, *move* will necessarily be a subtype of *act-pred* and *und-pred*. The required correspondence between the semantic and predicator hierarchies is illustrated in Figure 3.

(2) THE SEMANTIC SUBTYPE LINKING CONDITION

If s is a type in the semantic relations hierarchy and there exists a type in the word class hierarchy with CONTENT value of type s , then there exists a type $s-p$ in the word class hierarchy with CONTENT value of type s such that every type in the word class hierarchy with CONTENT a subtype of s is a subtype of $s-p$.

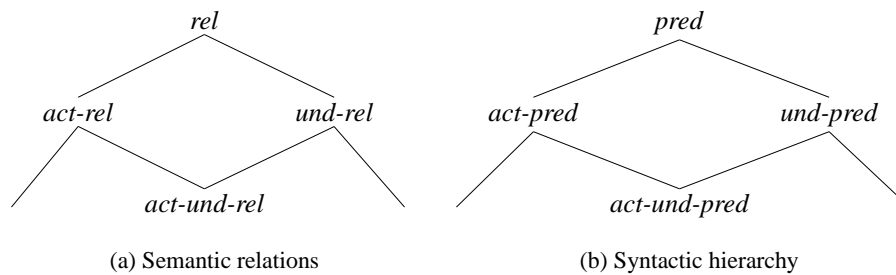

Figure 3: Homomorphism between semantic relation types and linking types

Together these three constraints ensure that all English verbs whose situational meaning can be categorized as a subtype of *act-und-rel* will realize their arguments the same way.¹

Despite the advantages of embedding a linking theory within a hierarchical lexicon detailed in Davis and Koenig (2000), Koenig and Davis (2001), and Davis (2001), there are at least three shortcomings of this approach. First, even though the attributes ACTOR and UNDERGOER are part of the semantic content of *move*, they are not semantically motivated attributes. Rather, their model-theoretic correlates are disjunctions of semantic properties, at least one of which holds of the referents of their values. Actors, for instance, may be volitional entities *or* causes, *or* impingers, and so forth. The main motivation for positing such attributes is the increased ease with which linking constraints can be stated. In that sense, the attributes ACTOR and UNDERGOER (and other attributes, as well) partially function as syntactic diacritics, as Ackerman and Moore (2001) mention. They violate what we call the *Transparency Principle*, which we state as follows:

Principle 1 (Transparency Principle) *Linking constraints must be stated in terms of semantically natural classes of properties of situations.*

The same shortcoming, as far as we can see, plagues the notions of ACTOR and UNDERGOER used in Role and Reference Grammar (Foley and Van Valin (1984)). Likewise, Pinker's (1989) resort to semantically arbitrary differences in *lexical semantic representations* can be seen as introducing syntactic diacritics where they

¹At least for "regular" verbs. The situation is different with verbs that idiosyncratically require a PP complement.

do not belong (see Davis and Koenig (2000a)). In all such cases, linking constraints crucially rely on semantically unmotivated devices that are only posited to make sure linking constraints properly apply. As such they introduce into semantic representations information that is best left out of it.²

Second, the principle in (2), which is crucial to ensuring that all (transitive) words having the right meaning will realize their arguments the right way, is theoretically unsatisfying. It embodies the logic behind linking regularities, namely that all words which denote a situation-type that belongs to the appropriate semantic category should link their arguments the same way, up to syntactic idiosyncrasy. As such, the principle should be part of the grammar of languages. But it cannot be represented within the logical formalism underlying HPSG grammars. Rather, it constitutes a meta-grammatical statement on a required higher-order similarity between two type hierarchies which has no clear logical place within HPSG.

Third, the types *act-pred* and *und-pred* violate the constraints on the introduction of types discussed in Meurers (2000). Types should only be posited for linguistic objects which bear some distinct properties from other linguistic objects. They should not simply serve to select the right kind of feature structures to which constraints must apply. Otherwise, the introduced types only duplicate categories of linguistic objects introduced elsewhere in the grammar. To take an extreme example, one should not introduce a type of *nominate-noun* simply to insure that nouns whose case is nominative bear the right inflectional suffix, since the category of nominative nominals is already selected by the HEAD feature value in (3). In other words, the type *nominate-noun* is redundant, since it serves to pick a class of linguistic objects, which the head value in (3) already selects.

$$(3) \left[\begin{array}{l} \textit{noun} \\ \textit{CASE nom} \end{array} \right]$$

Now, the types *act-pred* and *und-pred* bear no distinct properties; they simply select words whose semantic content is a relation of type *act-rel* and *und-rel*, respectively. In other words, they are only posited to ensure that words whose content is of type *act-rel* or *und-rel* link their actor argument correctly (and similarly, for other predicator types). These types violate Meurers' constraint on type introduction: They unnecessarily duplicate information already encoded in another part of the grammar.

Now, the main motivation for these three undesirable consequences lay in the logical formalism then widely used to write grammatical constraints in HPSG (basically, typed feature structures, as discussed in Carpenter (1992)). Implicational constraints of the form 'All words whose meaning is ... will ...' simply cannot be encoded because of the absence of negation (and quantification) within these languages (see Keller (1993) on that issue and Davis (2001) who remarks on this

²The Thematic Hierarchy, see Jackendoff (1972), Bresnan and Kanerva (1989), Grimshaw (1990), and Alsina (1992), among others, and Dowty's (1991) Proto-roles do not succumb to this difficulty, as they are explicitly recognized as interface constructs. But as Davis and Koenig (2000b) and Davis (2001) argue, other problems plague these constructs.

issue too). Implicational constraints in this formalism can only be indirectly modeled through the logic of inheritance.³ But this has two unfortunate consequences. First, it leads to a multiplication of the number of needed types in case of disjunctive statements like the ones informally stated in (4).

- (4) a. If a word has an argument that is entailed to be volitionally involved or a cause, or . . . , that argument is realized as the subject of its active form.
- b. If a word has an argument that is entailed to be undergoing a change of state, or impinged upon, . . . , that argument is realized as the object of its active form.

Since such conditional statements are modeled through inheritance relations between subtypes and supertypes, to insure that verbs which have *both* an argument that bears one of the properties mentioned in the antecedent of (4a) *and* an argument that bears one of the properties mentioned in the antecedent of (4b) link appropriately both arguments, we need to define at least as many types as the product of the number of properties mentioned in each antecedent, i.e. a *volitional-affected-rel*, a *notion-affected-rel* and so forth, one for each combination of properties of the denotata of the verb's relevant argument positions, so that all verbs whose arguments denote participants with such properties will inherit their semantic content from the appropriate relational type. This multiplicative effect, of course, increases in the case of three place predicates. The solution proposed in Davis and Koenig (2000), Koenig and Davis (2001), and Davis (2001) is to define a single argument class for each antecedent, the value of ACTOR and UNDERGOER, and define the constraints in terms of the values of these semantically unmotivated attributes.

The second unfortunate consequence of relying solely on inheritance to model implicational linking constraints is that in and of itself, positing a type *act-pred* does not exclude the possibility that a verb which has an argument bearing one of the proto-agent entailments is not a subtype of *act-pred*, and hence would incorrectly allow its "actor" argument to be linked to the object position. To exclude this possibility, Davis and Koenig (2000) and Davis (2001) are forced to posit the meta-grammatical constraint in (2).

Since the problem lies with the fact that implicational constraints are exclusively modeled through type-inheritance, the solution is quite simple, namely adopting a formalism for writing grammars that allows for true implicational statements. The RSRL language described in Richter (2000), expanding on King's (1989) SRL, is such a language. It allows us to model conditional logic through both implicational statements⁴ and type inheritance; we can then recast linking constraints in a way that avoids the three problems we mentioned.

³This is a slight simplification, as Carpenter also briefly discusses recursive type constraints systems. But, HPSG scholars typically have not made use of such systems, as far as we know.

⁴Strictly speaking, the meaning of implications, like all descriptions in RSRL, is not truth-conditional. We use this inaccurate way of speaking for expository purposes only. Nothing crucial hinges on this simplification.

2 How to achieve semantically transparent linking

2.1 Background constraints

First, we introduce model-theoretically transparent classes of relations, one for each relevant entailment. In place of the disjunctive *act-rel* and *und-rel*, and ACTOR and UNDERGOER, we postulate semantic relations based on individual characteristic entailments, since implicational statements directly relating lexical semantic properties to subcategorization properties render pseudo-semantic attributes like ACTOR and UNDERGOER unnecessary. Three such relations and their model-theoretic interpretations are represented in (5) below.⁵

- (5) $\left[\begin{array}{l} \textit{cause-rel} \\ \text{CAUSER } x \end{array} \right]$ denotes the class of situations that include a participant who is the referent of the value of CAUSER and who causes a change-of-state in another participant.
- (6) $\left[\begin{array}{l} \textit{volitional-rel} \\ \text{VOLITIONAL } x \end{array} \right]$ denotes the class of situations that include a participant who is the referent of the value of VOLITIONAL and who is volitionally involved in the situation.
- (7) $\left[\begin{array}{l} \textit{ch-of-st-rel} \\ \text{CHANGES-STATE } x \end{array} \right]$ denotes the class of situations in which the referent of the value of CHANGES-STATE is an entity changing state as a result of the event.

Second, to prevent linking from needlessly applying to all roots and stems, e.g., to the verbal stems in derived nominals such as *runner* or *revocation*, we must declare the attribute ARG-ST to only be appropriate for linguistic objects of type *word* (at least in languages like English).⁶ Linking constraints can now only apply to words. But we now need a way to infer the presence of certain elements on the ARG-ST list given the semantic content of words.

The constraints in (8) and (9) are an initial attempt to accomplish that. (ARG in these formulas functions as a variable over semantic roles names.) Only two constraints like those in (8) and (9) are needed. Davis and Koenig's (2000a)'s KEY hypothesis on the structure of lexical semantic representations is correct ensures that the semantic decomposition of lexical entries' semantic content never goes deeper than one level.⁷

The first constraint says that for each of the arguments in a word's CONTENT, there must be a member of the ARG-ST list whose semantic content corresponds

⁵ X in the diagrams stands for an unspecified value and is only used for purposes of exposition.

⁶We owe this suggestion to Jeff Runner and Raul Aranovich.

⁷The constraints in (8) and (9) are simplified in one important respect. In some cases the value of a verb's semantic role does not correspond directly to the semantic content of a member of the ARG-ST list, but rather to the value of an argument of that semantic content. This will occur when the relevant member of the ARG-ST list is a PP whose prepositional head is semantically potent and encodes a supertype of the meaning of the verb, as discussed in Wechsler (1995a) and Davis (2001). Nothing substantial hinges on this simplification.

to that argument. The second constraint says that for each argument of these arguments, there also is a member of the ARG-ST list whose semantic content corresponds to that argument.

$$(8) \left[\begin{array}{c} \text{CONT} \quad [\text{ARG } \boxed{1}] \\ \text{ARG-ST } \boxed{2} \end{array} \right] \Rightarrow \exists \boxed{3} (\text{member}(\boxed{3}, \boxed{2}) \wedge \boxed{3}[\text{CONTENT } \boxed{1}])$$

$$(9) \left[\begin{array}{c} \text{CONT} \quad \left[\text{ARG } [\text{ARG } \boxed{1}] \right] \\ \text{ARG-ST } \boxed{2} \end{array} \right] \Rightarrow \exists \boxed{3} (\text{member}(\boxed{3}, \boxed{2}) \wedge \boxed{3}[\text{CONTENT } \boxed{1}])$$

These constraints are strong. As formulated, they require that we confront phenomena such as the following:

- Denominal verbs, with arguments incorporated, in such cases as *butter*, *spit*, *jail*, *knife*, *juice*, and *summit*. If these verbs mean something like, e.g. “put in jail”, “remove juice from”, and “reach the summit of”, then why do the nouns these verbs are derived from not on the ARG-ST lists of the respective verbs, since the arguments are plausibly present in the CONTENT?
- Optional arguments, such as the understood objects of *read* and *sew*, and omissible PP complements of verbs such as *cover (with)*, *remove (from)*, and *explain (to)*, which seemingly require these arguments at a semantic level, even when not overtly present.
- More generally, many verbs denote types of actions that necessarily occur at a place and time or involve other entities (e.g., in spitting, there is a mouth involved) that are never denoted by the verb’s syntactic arguments, though they may be realized as adjuncts.

Some of these difficulties (perhaps all of them) can be overcome by distinguishing the value of CONTENT from a more general conceptual structure, which is not necessarily linguistic. In CONTENT, only the “linguistically relevant” arguments are present (this is very close to Pinker’s (1989) position, as distinguished from Jackendoff’s (1990) claim that there is only a single, unified level of conceptual structure). This move is potentially circular, however. We need independent criteria for determining what is linguistically relevant before we can explain away all the cases where an argument happens not to be syntactically realized.

We see at least two means of dealing with these issues. One is to say that the arguments are present in the CONTENT, but something precludes the constraints in (8) and (9) from applying. For instance the values of the attributes in question might be of a different type, say “non-discourse-referential”—by which we mean that they do not introduce a discourse referent in the discourse model—and that “non-referential” nominal indices cannot be associated with members of the ARG-ST list.⁸ This approach might also be generalized to lexically “incorporated” ar-

⁸See Koenig and Mauner (1999) for arguments that the unexpressed “agents” of short passive and what Fillmore (1986) calls indefinite null anaphors, more generally, do not introduce referents in the discourse model.

guments, such as *butter* and *spit*. Technically, the constraints in (8) and (9) would need to be modified so that they only apply to values of ARG attributes that are “discourse-referential”, as shown in (10) and (11).

$$(10) \left[\begin{array}{l} \text{CONT} \quad [\text{ARG} \quad \boxed{1} \text{disc-ref}] \\ \text{ARG-ST} \quad \boxed{2} \end{array} \right] \Rightarrow \exists \boxed{3} (\text{member}(\boxed{3}, \boxed{2}) \wedge \boxed{3}[\text{CONTENT} \quad \boxed{1}])$$

$$(11) \left[\begin{array}{l} \text{CONT} \quad \left[\text{ARG} \quad [\text{ARG} \quad \boxed{1} \text{disc-ref}] \right] \\ \text{ARG-ST} \quad \boxed{2} \end{array} \right] \Rightarrow \exists \boxed{3} (\text{member}(\boxed{3}, \boxed{2}) \wedge \boxed{3}[\text{CONTENT} \quad \boxed{1}])$$

The second tack is the one mentioned earlier—distinguishing between the linguistically relevant semantics of CONTENT and a more general conceptual structure. We believe that there is some value in this approach, despite the difficulties in formulating conditions for linguistic relevance. Note that the lexical semantic representations assumed in Koenig and Davis (2001) or Davis (2001) already adopt this strategy when minimalizing the amount of lexical decomposition involved in lexical semantic representations. They assume that only decompositions that are morphosyntactically relevant need be represented in the value of the CONTENT attribute of lexical entries. At least for some of the cases mentioned earlier, e.g., *butter* or *juice*, this strategy would lead to the conclusion that the semantic arguments are not part of the lexical entry’s CONTENT. This same strategy would, in other cases, lead to a different conclusion. For instance, the need to specify what “figure” the location PP in (12) is predicated of suggests that the verb *spit* includes that figure in its semantic CONTENT.

(12) Don’t spit into the soup.

Aside from this general strategy for deciding whether a semantic argument is the value of an attribute in a lexeme’s CONTENT, there might be independent reasons for not including some information in the lexical semantic representation of words. This is the case for the time and place at which events occur, as argued in Koenig *et al.* (2003). Space does not permit us to fully resolve the difficult issue of exactly how these challenges to the constraints in (8) and (9) are best met.⁹ These brief remarks should suggest several plausible avenues to achieve this proper restriction and we now turn to yet one more set of constraints that linking constraints rely on.

We posit the default canonical realization rule in (13) (together with a few others) to help infer the part-of-speech category of members of the ARG-ST list (see Pesetsky (1982) and Langacker (1987) for the notion of canonical realization principles). The constraint in (13) says that, if the semantic content of a member of the ARG-ST list is a nominal index (basically, the equivalent of an objectual discourse referent in DRT), then the part-of-speech of that argument will be nominal.

⁹Our brief discussion also does not address either the issue of words which obligatorily select expletives, such as *falloir* ‘must’ in French and whose stems must include some argument-structure information, even if not in the form of an ARG-ST list member.

$$(13) \left[\text{ARG-ST} \left\langle \dots \boxed{\text{CONTENT}} \left[\text{INDEX } \textit{nom-index} \right] \dots \right\rangle \right] \\ \Rightarrow \left[\text{ARG-ST} \left\langle \dots \boxed{\text{HEAD}} \textit{/noun} \dots \right\rangle \right]$$

2.2 Linking constraints

Now that we have shown how to represent implicational logic using both type inheritance and truly implicational constraints as well as introduced the relevant lexical semantic representations, and a few constraints on the relation between semantic and syntactic arguments and the default part-of-speech of the syntactic arguments realizing some semantic type, we can state the linking constraints needed for English, at least for direct syntactic arguments. As will be clear, the constraints are now somewhat trivial and few in number. The linking constraint for verbs whose semantics involves a causer, like transitive uses of *move* in (1), is shown at the top of Figure 4. The constraints for verbs with semantics involving a volitional agent and for verbs whose semantics involve a participant having a mental representation of another participant are stated below.

$$\left[\begin{array}{l} \text{CONTENT } \textit{cause-rel} \\ \text{ARG-ST } \langle \text{NP}, \dots \rangle \end{array} \right] \Rightarrow \left[\begin{array}{l} \text{CONT } \left[\text{CAUSER } \boxed{\text{I}} \right] \\ \text{ARG-ST } \langle \text{NP}:\boxed{\text{I}}, \dots \rangle \end{array} \right]$$

$$\left[\begin{array}{l} \text{CONTENT } \textit{volit-rel} \\ \text{ARG-ST } \langle \text{NP}, \dots \rangle \end{array} \right] \Rightarrow \left[\begin{array}{l} \text{CONT } \left[\text{VOLITIONAL } \boxed{\text{I}} \right] \\ \text{ARG-ST } \langle \text{NP}:\boxed{\text{I}}, \dots \rangle \end{array} \right]$$

$$\left[\begin{array}{l} \text{CONTENT } \textit{notion-rel} \\ \text{ARG-ST } \langle \text{NP}, \text{NP}, \dots \rangle \end{array} \right] \Rightarrow \left[\begin{array}{l} \text{CONT } \left[\text{EXPERIENCER } \boxed{\text{I}} \right] \\ \text{ARG-ST } \langle \text{NP}:\boxed{\text{I}}, \dots \rangle \end{array} \right]$$

Figure 4: The linking constraint for causal, volitional, and experiencer verbs

The constraints say that if an argument of the relation denoted by a predicator is a cause, a volitional entity, or an entity having a mental representation of another entity, then, the expression of this argument corresponds to the first member of the ARG-ST list. Because the implicational statements in Figure 4 behave logically (to simplify a bit) like the material conditional, any feature structure that satisfies the antecedent will necessarily satisfy the consequent. There is therefore no need for the meta-grammatical constraint in (2) anymore. That all verbs whose CONTENT includes a relation which is a subtype of *causal-rel* must link their causal argument to the first member of their ARG-ST lists simply falls out from the logical behavior of the type hierarchy and implicational statements. What was an extra grammatical constraint has now become a logical consequence in the logical formalism through which HPSG grammars are written.

In the proposed new approach to linking, there will, therefore, be one implicational constraint for each characteristic entailment in the sense of Koenig and

Davis (2001). This will clearly result in an increased number of linking constraints for linking the semantic roles corresponding to the old ACTOR attribute, but, because each implicational statement’s “truth” is independent of the “truth” of other implicational statements, no multiplicative effect and loss of generalization arises. Positing separate linking constraints for volitional agents and causers does not require multiplying linking constraints when linking of both “proto-agents” and “proto-patients” (or linking of three-place predicates) is considered. The increase in number of linking constraints is simply the minimum needed to avoid the use of semantic attributes as syntactic diacritics and abide by the Transparency Principle. We can therefore truly base linking entirely on the atomic model-theoretic properties of participants without running the risk of having to repeat the constraints for “proto-agent” linking when linking “proto-patient” and other arguments. In fact, given (default) canonical realization principles as in (13), we can dispense with any implicational linking constraint to replace the UNDERGOER linking class in Davis and Koenig (2000b). Undergoers are simply participants which, because of their semantic type, are, by default, realized as nominal syntactic arguments, i.e. as some NP member of the ARG-ST list, by the constraints in (8) and (13). We do not need to specify *where* on the ARG-ST list, these NPs are. They cannot be first, because of the constraints listed above in Figure 4. They will, as a consequence, be the last NP on the list in the case of the transitive verbs. They will too, in the case of ditransitive verbs, given the linking constraint for ditransitive verbs stated in Figure 5 (adapted from Davis and Koenig (2000b)) and similar ones for other semantic uses of the ditransitive valence in English, which insures that the recipient of transfer of possession verbs is linked to the second member of the ARG-ST list.

$$\left[\begin{array}{l} \text{CONTENT } \textit{transfer-possess-rel} \\ \text{ARG-ST } \langle \text{NP}, \text{NP}:\boxed{3}, \text{NP} \rangle \end{array} \right] \Rightarrow \left[\text{CONTENT } \left[\text{EFFECT } \left[\text{POSSESSOR } \boxed{3} \right] \right] \right]$$

Figure 5: The linking constraint for ditransitive verbs.

Although linking constraints for a single “argument position” will be more numerous in this revised approach to linking (there will be more than one linking constraint for proto-agents and proto-recipients, to speak loosely), each linking constraint now obeys the semantic transparency principle. There are two further important consequences of this revised linking theory. First, each linking constraint only concerns itself with a single property of participants in the described situations, since the constraints’ antecedent now only mention semantic relations identified by a single property of one of their arguments. As such, our linking constraints abide by the hypothesis argued for in Koenig and Davis (2000) and stated below.

Hypothesis 1 (Singleton Property Hypothesis (SPH)) *A single characteristic entailment of the denotation of a semantic attribute’s value is sufficient to determine its linking.*

Contrary to the claim put forth in Dowty (1991) and Ackerman and Moore (2001) that linking constraints must rely on comparing the cardinality of sets of participant properties, Koenig and Davis argue that determining the linking of semantic arguments is simpler. Knowing whether an argument bears *one* of a relatively small set of properties (between ten and twenty, see Carlson (1998)), is sufficient to determine its syntactic realization.

Second, the proposed new linking constraints also restrict the range of permitted lexical semantic representations. For example, the first two constraints in Figure 4 both require a certain type of participant to be realized as the first element on the ARG-ST list. Thus, if both semantic types apply to a situation type, the participants linked by the two rules must be one and the same, as shown in Figure 6. This effectively performs the same task of grouping these participants that was performed by treating ACTOR as a disjunctive attribute.

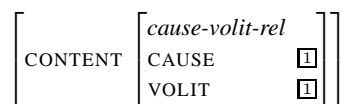

Figure 6: Situation involving volitional causes

To conclude, this paper shows how to achieve complete semantic transparency of linking constraints within HPSG by relying both on inheritance hierarchies and implicational statements. Such an approach provides the means to capture the semantic generalizations which underlie linking constraints without the need to introduce unmotivated semantic attributes. It also preserves the insights of Davis and Koenig (2000a), Davis and Koenig (2000b), and Koenig and Davis (2001). In particular, our revised linking theory can incorporate as is the hypothesis that only non-modal situation information of the KEY elementary predication is relevant to the linking of direct arguments. We have also illustrated some of the potential benefits of switching from the Feature-Logic approach to grammar formalism adopted in Carpenter (1992) to the more recent RSRL approach. Interestingly enough, the increased benefits in the linguistic modeling of linking constraints from countenancing both inheritance-based and implication-based models of conditional logic echo some of the discussions on the speed vs. generality trade-off of so-called path-based and rule-based inferencing in Knowledge Representation and Reasoning systems (see Shapiro (1991))

References

- ACKERMAN, FARRELL, and JOHN MOORE. 2001. Proto-properties and Grammatical Encoding: A Correspondence Theory of Argument Selection. Stanford: CSLI Publications.
- ALSINA, ALEX. 1992. On the argument structure of causatives. *Linguistic Inquiry* 23.517–556.

- BRESNAN, JOAN, and JONNI KANERVA. 1989. Locative inversion in chicheŵa: A case study of factorization in grammar. *Linguistic Inquiry* 20.1–50.
- CARLSON, GREG. 1998. Thematic roles and the individuation of events. *Events and grammar*, ed. by Susan Rothstein, 35–51. Dordrecht: Kluwer.
- CARPENTER, BOB. 1992. *The Logic of Typed Feature Structures*. Cambridge: Cambridge University Press.
- DAVIS, ANTHONY. 2001. *Linking by Types in the Hierarchical Lexicon*. Stanford: CSLI Publications.
- , and JEAN-PIERRE KOENIG, 2000a. The KEY to lexical semantics. *7th International Conference on Head-driven Phrase-Structure Grammar*.
- , and ———. 2000b. Linking as constraints on word classes in a hierarchical lexicon. *Language* 76.56–91.
- DOWTY, DAVID. 1991. Thematic proto-roles and argument selection. *Language* 67.547–619.
- FILLMORE, CHARLES. 1986. Pragmatically controlled zero anaphora. *Proceedings of the 12th annual meeting of the Berkeley Linguistic Society*, 95–107. Berkeley Linguistic Society.
- FOLEY, WILLIAM, and ROBERT VAN VALIN. 1984. *Functional Syntax and Universal Grammar*. Cambridge: Cambridge University Press.
- GOLDBERG, ADELE. 1995. *Constructions: A Construction Grammar Approach to Argument Structure*. Chicago: Chicago University Press.
- GRIMSHAW, JANE. 1990. *Argument structure*. Cambridge, Mass: MIT Press.
- JACKENDOFF, RAY. 1972. *Semantic Interpretation in Generative Grammar*. Cambridge, MA: MIT Press.
- . 1990. *Semantic Structures*. Cambridge: MIT Press.
- KELLER, BILL. 1993. *Feature Logics, Infinitary Descriptions and Grammars*. Stanford: CSLI Publications.
- KING, PAUL, 1989. *A Logical Formalism for Head-Driven Phrase Structure Grammar*. Manchester: University of Manchester dissertation.
- KOENIG, JEAN-PIERRE, and ANTHONY DAVIS. 2001. Sublexical modality and the structure of lexical semantic representations. *Linguistics and Philosophy* 24.71–124.
- KOENIG, JEAN-PIERRE, and GAIL MAUNER. 1999. A-definites and the semantics of implicit arguments. *Journal of Semantics* 16.207–236.

- , ——, and BRETON BIENVENUE. 2003. Arguments for adjuncts. *Cognition* 89.67–103.
- LANGACKER, RONALD. 1987. *Foundations of Cognitive Grammar*, vol.1. Stanford: Stanford University Press.
- LEVIN, BETH. 1993. *English Verb Classes and Alternations*. Chicago: Chicago University Press.
- MEURERS, DETMAR, 2000. *Lexical Generalizations in the Syntax of German Non-Finite Constructions*. Tübingen: Universität Tübingen dissertation.
- PESETSKY, DAVID, 1982. *Paths and Categories*. Cambridge, MA: MIT dissertation.
- PINKER, STEVEN. 1989. *Learnability and Cognition: the acquisition of argument structure*. Cambridge, MA: MIT Press.
- RICHTER, FRANK, 2000. *A Mathematical Formalism for Linguistic Theories with an Application in Head-driven Phrase Structure Grammar*. Tübingen: Universität Tübingen dissertation.
- SHAPIRO, STUART. 1991. Cables, paths, and “subconscious” reasoning in propositional semantic networks. *Principles of semantic networks: Explorations in the representation of knowledge*, ed. by J. Sowa, 137–156. San Mateo, CA: Morgan Kaufmann.
- WECHSLER, STEPHEN. 1995a. Preposition selection outside the lexicon. *Proceedings of wccfl xiii*, ed. by Raul Aranovich, William Byrne, Susanne Preuss, and Matha Senturia, 416–431. Stanford: CSLI Publications.
- . 1995b. *The Semantic Basis of Argument Structure*. Stanford, CA: CSLI Publications.

Some empirical issues in the grammar of extraction

Robert D. Levine 

Ohio State University

Ivan A. Sag

Stanford University

Proceedings of the 10th International Conference on
Head-Driven Phrase Structure Grammar

Michigan State University

Stefan Müller (Editor)

2003

Stanford, CA: CSLI Publications

pages 236–256

Levine, Robert D. & Ivan A. Sag. 2003. Some empirical issues in the grammar of extraction. In Stefan Müller (ed.), *Proceedings of the 10th International Conference on Head-Driven Phrase Structure Grammar*, Michigan State University, 236–256. Stanford, CA: CSLI Publications. DOI: 10.21248/hpsg.2003.14. 

Abstract

This paper compares transformation-based and constraint-based treatments of unbounded filler-gap dependencies, the latter specifically as articulated in terms of HPSG, and argues, contrary to the commonly made allegations of ‘notational variance’, that there is purely empirical evidence that is consistent with only the constraint-based account. Recent proposals to deal with parasitic gaps in terms of null pronominals and ‘empty operators’ are unable to account for the phenomenon of ‘symbiotic’ gaps, the apparent case mismatches found in parasitic gap constructions, or (in general) for the well-known ‘across-the-board’ effects within coordinate structures.

1 Filler/Gap Constructions: Two Approaches

Historically, filler/gap constructions (or unbounded dependency constructions – UDCs) such as those in (1) have been approached two ways:

- (1) a. THAT book, you should purchase ____.
- b. Which book does Leslie think you should purchase ____?
- c. This is the book which Leslie told me she thinks I should purchase ____.

Transformational approaches posit a sequence of representations in which the filler is initially in the position notated by the underline in (1), which is then relocated, possibly via a series of movement steps, to its final position on the left of the highest clause. Schematically, the derivational approach can be illustrated in (2):

[†]The ideas presented here are developed in greater detail in Levine and Sag 2003. We would like to thank John Beavers for comments on an earlier draft. We also thank a number of people, discussions with whom have had an influence on the ideas presented here. These include John Beavers, Emily Bender, Mike Calcagno, Jonathan Ginzburg, Takao Gunji, Tom Hukari, David Johnson, Shalom Lappin, Carl Pollard, Tom Wasow, and two anonymous reviewers. A special thanks is due Gerald Gazdar, whose ideas we have built on in fundamental ways. Finally, this paper was prepared while Sag was a Fellow at the Center for Advanced Study in the Behavioral Sciences, supported by a grant (# 2000-5633) to CASBS from The William and Flora Hewlett Foundation.

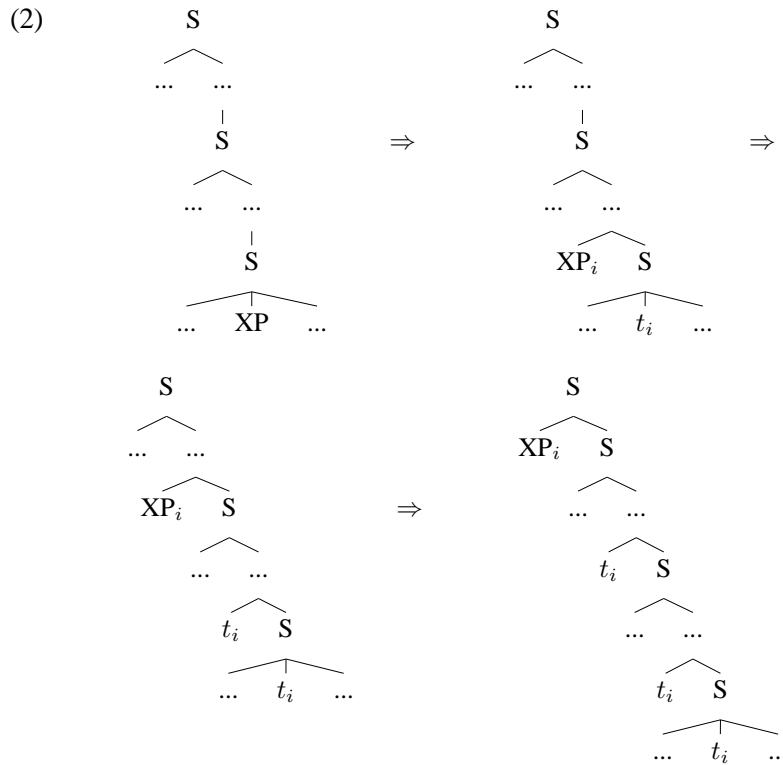

The bottom-up derivations found in current work within the Minimalist Program are similar in relevant respects. They differ primarily as to where the higher structure is introduced within a derivation.

There are two crucial aspects to the analysis depicted in (2): (i) the filler is the same object at the end of the derivation as the in-situ category at the beginning of the derivation, merely relocated by movement, and (ii) a series of intermediate traces is left at each of the positions occupied by the trace in transit in addition to the trace demarcating its original position prior to movement. Compare this picture to the HPSG connectivity mechanism linking fillers and gaps given in (3):

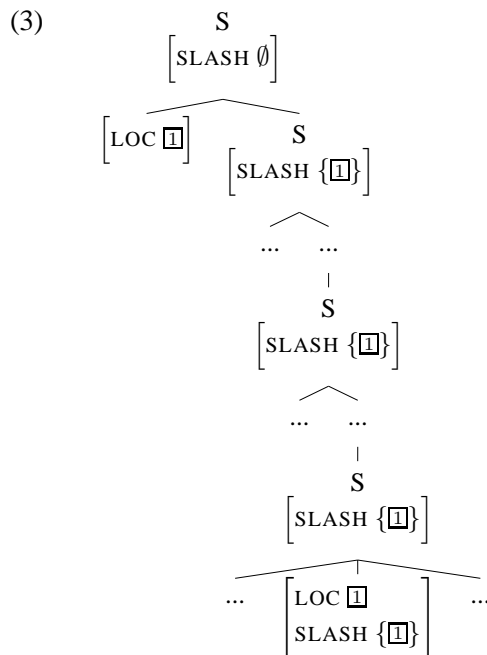

Casual comparison of (2) and (3) would suggest that these representations are essentially equivalent, *as long as you only look at single filler/gap constructions*. Indeed, Chomsky has insisted, over much of his career, on the empirical indistinguishability of monostratal representations with ‘base generated gaps’ with derivationally derived gaps as per (2). In *LGB*, for example, he not only asserts their ‘virtual indistinguishability’, arguing that the problem of choosing between them is ‘a fairly marginal one’, but makes the unsubstantiated (and factually incorrect) claim that all nonderivational theories of filler/gap linkages are ‘transformational theories, whether one chooses to call them that or not’. Over the past two decades, the notion seems to have circulated in certain circles that monostratal feature-linkage analyses of filler/gap constructions are nothing more than old wine in new, not very interesting bottles.

This is a charge that might be legitimately levelled at GB treatments of syntactic unaccusativity vis-à-vis the original Relational Grammar studies of that phenomenon. However, we argue that it has no merit in the comparison of (2) and (3). Not only are there clear framework-architectural differences between the approaches, it turns out that multiple gap constructions make very clear, on purely factual grounds, the inferiority of derivational approaches.

2 What Multiple Gap Constructions Tell Us

The first point is straightforward: in a single filler/multiple gap construction, such as the parasitic gap phenomenon, the finale of the derivational picture looks not like that in (2), but rather like (4):

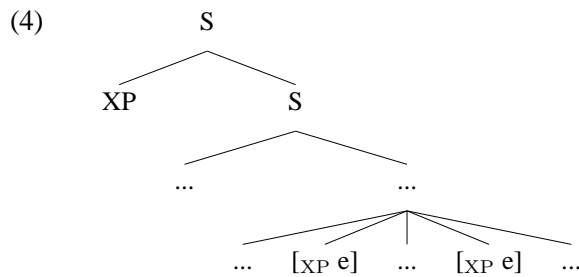

What is the relationship between the filler and the two gaps? There is no well-defined formal operation corresponding to movement of two distinct daughter constituents to a single phrase structure position, as emphasized by Gazdar et al. (1982). That is, a single linkage mechanism to the two gap sites is in principle unavailable under the movement analysis. Therefore there appear to be only two possible choices:

- there is a single linkage mechanism between the filler and one of the gaps and a different linkage mechanism between the filler and the other gap; or
- there is only a single kind of linkage mechanism available between fillers and gaps, and in multiple gap construction there are two separate instances of the same mechanism.

In the first case, there is an obvious asymmetry: one of the gaps must represent a trace of the filler, so that the other position must be occupied by a phonologically null element which is something other than a trace. In the second case, movement is the sole linkage mechanism involved in both cases, which entails that there is, in addition to the movement bringing the overt filler to its surface position, a second movement leaving the second trace – with a second moved element that must be invisible. Here the asymmetry is between the movement chain linking the overt filler to the gap site, on the one hand, and that linking the null filler to the gap site.

Both variants, as well as various hybrids, exist in the literature. Sticking to very familiar examples, Chomsky 1982 manifests the first alternative and Chomsky 1986 the second. But the plausibility of such approaches is only as strong as the arguments for the asymmetry assumed. There are remarkably few of these, in fact.

2.1 The Kearney Paradigm

The primary argument in the literature, as far as we are aware, is given in Chomsky 1986. Chomsky cites the following two examples, due to Kearney (1983):

- (5) a. Which books about himself did John file *t* [before Mary read *e*]?
 b.*Which books about herself did John file *t* [before Mary read *e*]?

Chomsky observes that:

[e]xample [(5a)] is a normal parasitic gap construction, but [(5b)] is ungrammatical. It follows, then, that the *wh*-phrase in [(5a)], [(5b)] is extracted from the position of *t*, not from the position of the parasitic gap *e*. As Taraldsen had originally assumed, the latter is truly ‘parasitic’.

Frampton (1990, p. 58) cites the same data in support of Chomsky’s line of reasoning about the source of (5). While hardly transparent, that reasoning appears to be the following: if p-gap constructions were in fact instances of some kind of multiple-gap (i.e. symmetrical) phenomenon, then reconstruction of the filler should proceed symmetrically to yield identical effects in (5a) and (5b). In both cases, the result would be a representation in which an anaphor was compatible with its antecedent in one of the sites but not in the other. Hence, on the crucial assumption that the ill-formedness of (5b) arises from reconstruction of an anaphor into a gap site where only an incompatible antecedent is present, we would expect (5a)—where *which books about himself* is reconstructed to a site where *Mary* must antecede the anaphor—to be just as bad. But this is not what we find. Rather, the general pattern is that when the anaphor is compatible with a main clause subject antecedent, the result is good, and when it is not, the result is bad. Hence, the simplest conclusion is that the overt filler reconstructs only to the main clause gap site, which must then be its transformational point of origin.

But this conclusion is inconsistent with previously overlooked examples like (6):

- (6) a. There were pictures of herself which, once Mary finally decided she liked __, John would have to put __ into circulation.
- b. There were pictures of himself which, once Mary finally decided she liked __, John would be able to put __ into circulation.

(6a,b) instantiate the ‘fronted adverbial’ p-gap construction discussed in general terms for the first time, to our knowledge, in Haegeman 1984. Examples like these demonstrate that binding patterns reveal nothing about the extraction site of the *wh*-phrase, even on Chomsky’s own line of reasoning. No matter which gap is taken to be the ‘true’ gap in adverb fronting, the fact that both *John* and *Mary* are possible reflexive antecedents shows that the distinction between true and parasitic gap is irrelevant to the determination of anaphor binding.

These observations, incidentally, are exactly as predicted by the convergent binding theories of Pollard and Sag (1992) and Reinhart and Reuland (1993), who demonstrate that Principle A cannot be the basis for determining the antecedent of anaphors in ‘picture noun’ phrases. Clearly, extragrammatical factors such as point-of view, intervening potential controllers, and proximity play a significant role in defining the notion of prominence that determines well-formedness in cases

like those we have been looking at. The importance of proximity is underlined by further contrasts like the following, involving across-the-board extraction:

- (7) Which pictures of himself/*herself did John approve of ___ and Mary like ___ enormously?

This observation about ATB extraction is not inconsistent with the assumption that picture noun reflexives are governed by extragrammatical factors, as argued at length by Pollard and Sag (1992, 1994). Under the assumptions made by Chomsky or by Frampton, however, these data make no sense whatsoever. The conclusion we come to then is that the Kearney paradigm has been badly misunderstood since it was first introduced into the literature as a justification for the putative asymmetry of p-gap constructions, and in fact is at best irrelevant to the question.

2.2 Nominative Subject P-Gaps

A second argument for chain asymmetry is given in Chomsky 1982, Cinque 1990, Frampton 1990 and Postal 1998, based on the supposed ill-formedness of parasitic gaps in finite subject positions. Examples such as those in (8) are often offered as illustrations of this claim:

- (8) a. *Jack, who_i I heard about ____i before you said ____i would hire us... (Frampton 1990, p.68.)
b. *Someone who_i John expected ____i would be successful though believing ____i is incompetent... (Chomsky 1982, p.55)
c. *The militant who they arrested ____i after learning ____i was carrying a gun...

Since true gaps have no problem extracting from finite subject position, such examples, taken to be representative, have been important supporting evidence for the position that parasitic gaps really involve a different relation to overt fillers than true gaps do. But again, examination of a slightly wider range of data shows that whatever difficulty such examples pose for acceptability, they are very far from being representative of the general case. Consider the examples in (9):

- (9) a. [Which people]_i did you invite ____i without thinking ____i would actually come.
b. Jack, who_i even before you said ____i would hire us I was favorably disposed towards ____i, is a prince among men.

There are so many good examples of such p-gaps that the claim that they are in general bad seems without any solid foundations.

2.3 Symbiotic Gaps

The foregoing discussion has shown that the chief published arguments for chain asymmetry in derivational theories of p-gap licensing are unsound. We now examine evidence that poses further difficulties for chain-asymmetric approaches to multiple gap constructions. Consider the data in (10), where *both* gaps seem to be within islands:

- (10) a. What kinds of books do authors of __ argue about royalties after writing __?
b.??What kinds of books do authors of malicious pamphlets argue about royalties after writing __?
c.*What kinds of books do authors of __ argue about royalties after writing malicious pamphlets?

If either gap is a ‘true’ gap, then the argument for chain asymmetry essentially disappears in the case of subject-gap/main VP gap or main VP gap/adjunct gap p-gap constructions – in which case multiple-chain analyses such as the *Barriers* analysis make no sense. The only defensible position seems to be to assume that subject and adjunct gap are *mutually parasitic*, or as we shall call them, SYMBIOTIC, i.e. depend on *each other* for licensing.

Can such constructions actually be licensed by movement approaches? The short answer is no. We reason as follows: First, under Chomsky’s (1982) approach in *Concepts and Consequences* (see also Cinque 1990), a parasitic gap starts out in DS as *pro*, and is subsequently coindexed with the filler linked to the ‘true’ gap site; otherwise identification of *pro* is impossible (or the functionally determined equivalent reasoning). Island conditions apply to all variables, regardless of how they arise. But both gap sites are islands. Hence there is no legal extraction to establish a filler that can license the other gap.

Next, on Kayne’s 1983 ‘connectedness’ approach, a parasitic gap can only establish a connection to a parasitic gap if the path from the parasitic gap to the true gap can be continuously mediated in terms of what Kayne calls the g-projection path. Longobardi (1984) showed that in order to work correctly, Kayne’s definition of g-projection path had to be strengthened with a proper government requirement. It turns out however that the g-projections of the subject gap and the adjunct gap both terminate before a connected path can be established, leaving the legal examples in (10) presumably unlicensed, as charted in (11), where superscripts indicate g-projections:

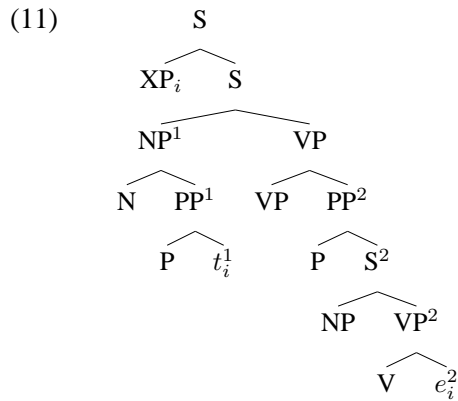

But in Chomsky's (1986) account (the *Barriers* analysis), both the adjunct and the subject function both as barriers and as blocking categories, which ensures that the dominating maximal projections closest to them (VP and IP respectively) are barriers. On this analysis, the empty operator within the subject cannot remain in situ since it will receive no interpretation at LF. But it cannot move out of the NP(DP) since, by stipulation, it can neither adjoin to NP(DP) nor move to Spec of CP, since that would involve crossing two barriers. But even if it could move out of the NP(DP) to [Spec,CP], it would be separated from the empty operator heading the parasitic chain by the barriers CP and VP, both of which are (intended to be) barriers for the empty operator heading the parasitic chain. Therefore the approach in Chomsky 1986 makes the incorrect prediction that examples such as (10) are ill-formed, as shown in (12), where unoccupied Spec positions have been suppressed:

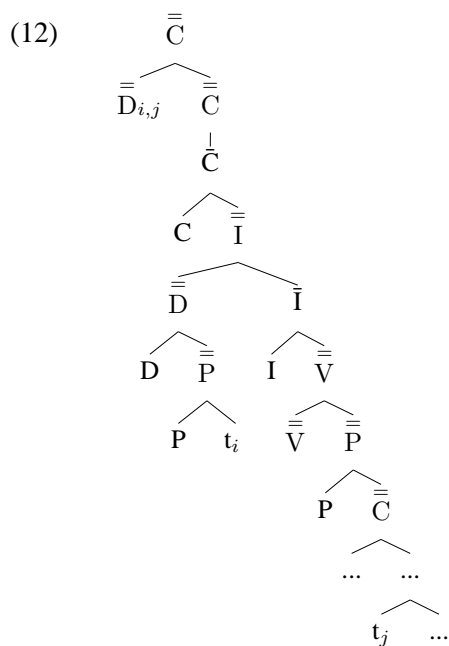

Finally, Frampton's (1990) treatment of parasitic gaps, a kind of hybrid of Kayne's connectedness with Chomsky's null operator treatment in *Barriers*, is in effect a derivational reconstruction of the multiple licensing of extractions pathways linked to a single filler. Everything we've said about Kayne carries over directly. We need only replace the notion 'g-projection' with 'trace-chain' and 'connectness' with 'inverted Y-path':

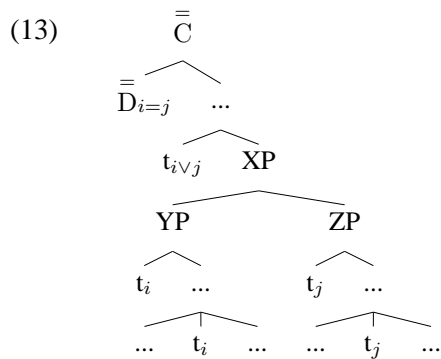

And the same problem with connectedness in these cases carries over to Frampton's trace-based analogue. The upshot of all this is that no reasonably explicit P&P theory of p-gaps has even the beginnings of an adequate account of symbiotic gaps. In section 3.2 below, we propose a reassessment of the data in (10) and sketch an account in terms of Pollard and Sag's (1994) Subject Condition.

2.4 The Case Conflict Conundrum

Finally, consider examples such as (14):

- (14) Robin is someone who_i even good friends of ___i believe ___i likes power entirely too much.

The filler here is linked to two gap sites, an accusative prepositional object and a nominative finite clause subject. Such mismatches seem to support the position that there is an asymmetry between the two chains that p-gap constructions comprise: if both gaps were linked to a single filler in precisely the same way, the latter would have to share case specifications with both gap sites. In contrast, a double chain analysis, for example, along *Barriers* lines, seems to fit the bill: there will be literal connectivity only along the true filler/gap pathway, while the null operator is linked to the true filler/gap pathway only anaphorically, sharing indices but no ϕ features, so that we would have the situation in (15):

- (15) wh_i [Nom]... O_i [Acc]...t_i [Acc]...t_i [Nom]

So the possibility of case mismatches seems to be predicted. This might appear to be a plus for the asymmetrical chain analysis.

But appearances are often deceptive. It turns out that none of the movement approaches we have considered has a straightforward way of accounting for the fact that *such mismatches will occur only when the overt filler is morphologically neutral with respect to case marking*. On the *Barriers* approach, the true and parasitic gap are supposed to be case-independent of each other. So why then do we have the following data?

- (16) a. *Him_i , even friends of ___i think ___i likes power entirely too much.
 b. He_i, I very much DOUBT __ wants to have anything to do with us.
 c. Robin is someone who(*m)_i once I realized ___i WOULD be coming to the party I made a special point of being nice to ___i .

The *Barriers* analysis gets these facts dead wrong: if the two chains are linked purely by Chain Composition in such a way that (14) is good, then certainly (16a) should be good, since the structure is literally identical to that of (15):

- (17) Him_i [Nom]... O_i [Acc]...t_i [Acc]...t_i [Nom]

All that is different is that you can see the case on the filler, i.e. the pronoun *him* shows its case morphologically. On the other hand, (16c) is nothing more than the mirror image of (15):

- (18) whom_i [Acc]... O_i [Nom]...t_i [Nom]...t_i [Acc]

Again, though it seems to be something of an urban legend that finite clause subject p-gaps are ungrammatical, there appears to be nothing ungrammatical about the case-neutral version of (16c), which presumably is structurally indistinguishable from (18). What makes all the bad cases bad seems to be nothing more than the overt morphological form of the same case specification which supposedly corresponds to good examples when it is covert. Why is the same case good when it has no morphological realization, and bad when it does not? Alternatively, one could assume that Case identity between the two chains really was a condition on chain composition – in which case, one would incorrectly predict the badness of (14). This dilemma seems deeply problematic. Moreover, a variant of this double bind undercuts every one of the movement-based approaches we have considered, and various others as well.

2.5 Across-the-Board Extraction

Finally, let us now consider multiple gaps in coordinate structures. Critical examples here include the following:¹

¹We ignore here the issue of asymmetric conjunction and apparent counterexamples to the Coordinate Structure Constraint. For discussion and debate on the status of this constraint, see Postal 1998 (Chapter 3), Levine 2001, and Kehler 2002 (Chapter 5).

- (19) a.*[Which dignitaries]_i do you think [[Sandy photographed the castle] and [Chris visited ___]]?
- b.*[Which dignitaries]_i do you think [[Sandy photographed ___] and [Chris visited the castle]]?
- c. [Which dignitaries]_i do you think [[Sandy photographed ___] and [Chris visited ___]]?
- (20) a.*[Which of her books]_i did you find both [[a review of Gould] and [a reply to ___]]?
- b.*[Which of her books]_i did you find both [[a reply to ___] and [a review of Gould's new book]]?
- c. [Which of her books]_i did you read both [[a review of ___] and [a reply to ___]]?

These are of course the familiar data commonly referred to as Ross's (1967) Coordinate Structure Constraint and its 'across-the-board' exceptions.

As noted earlier, Gazdar et al. (1982) showed that a single mechanism linking fillers and gap sites in all relevant cases is in principle unavailable under the movement analysis. That is, it remains unclear how multiple gaps in across-the-board extraction structures are to be associated with a single filler. This objection has never been properly addressed in the transformational literature of the two decades that have transpired since the publication (in *Linguistic Inquiry*) of Gazdar et al.'s paper. We take this to be a testament to the correctness of Gazdar et al.'s conclusions.

3 A Feature-Based Analysis of Multiple Gaps

3.1 The Feature-Based Analysis of UDCs

The constraint-based phrase-structure theoretic analysis of parasitic gaps incorporates the fundamental insights about this phenomenon that begin with Gazdar 1981 – in particular, the observation that in the absence of any constraint to the contrary, a SLASH specification on a mother category can match a separate identical SLASH specification on each of any number of daughters. In Pollard and Sag 1994, this account of the origin of parasitic gaps is built into the formulation of the Nonlocal Feature Principle given in (21):²

(21) **The Nonlocal Feature Principle (NLFP):**

In any construction, the mother's SLASH value is the union of the daughters' SLASH values minus the BIND value of the head daughter.

²This formulation of the NLFP is restricted to the feature SLASH. Relative clauses have been treated in terms of the nonlocal feature REL (Pollard and Sag 1994; Sag 1997). Ginzburg and Sag (2000) treat interrogatives and exclamatives in terms of the nonlocal feature WH.

The value of BIND will be specified so that it is empty in general, but will contain an appropriate element v , just in case a given word (e.g. *tough*) or construction licenses the introduction of non-empty SLASH specification containing v . Above any such binding point, the set value of SLASH will not contain v . Thus BIND plays the role of a regulator, ensuring that nonlocal feature values only appear at the point where they are ‘launched’, and only propagate down below this point to the place in the structure where they are cashed out as a gap.³

Note, in particular, that as long as two daughters of a given category share identical SLASH values, that single SLASH value will also appear on the mother as the union of its daughters’ specifications for SLASH, and the same structure can be extended to include any number of daughters:

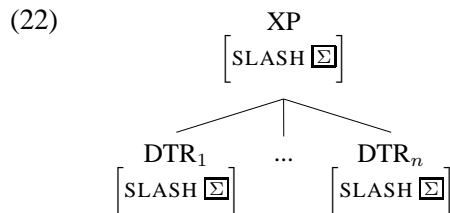

Unlike earlier feature-based proposals, e.g. that of Gazdar et al. 1985, here there is no pressure on SLASH to follow a path from head to head, wherever else it may appear.⁴ Hence the NLFP provides a unified account of individual gaps (on or off head paths) and multiple-gap constructions, where both head and nonhead paths bear identical SLASH features. Note further that this same mechanism will yield both of the following structures:⁵

³In the case of SLASH. Other nonlocal features, such as WH or REL, will be cashed out as appropriate *wh*-words. Our BIND feature plays a role similar to that of Pollard and Sag’s (1994) TO-BIND feature.

⁴But see the proposal of Ginzburg and Sag (2000).

⁵We appeal to binding theory to account for the deviance of examples like (i):

(i) *Who did they explain $_i$ to $_i$.

(23)

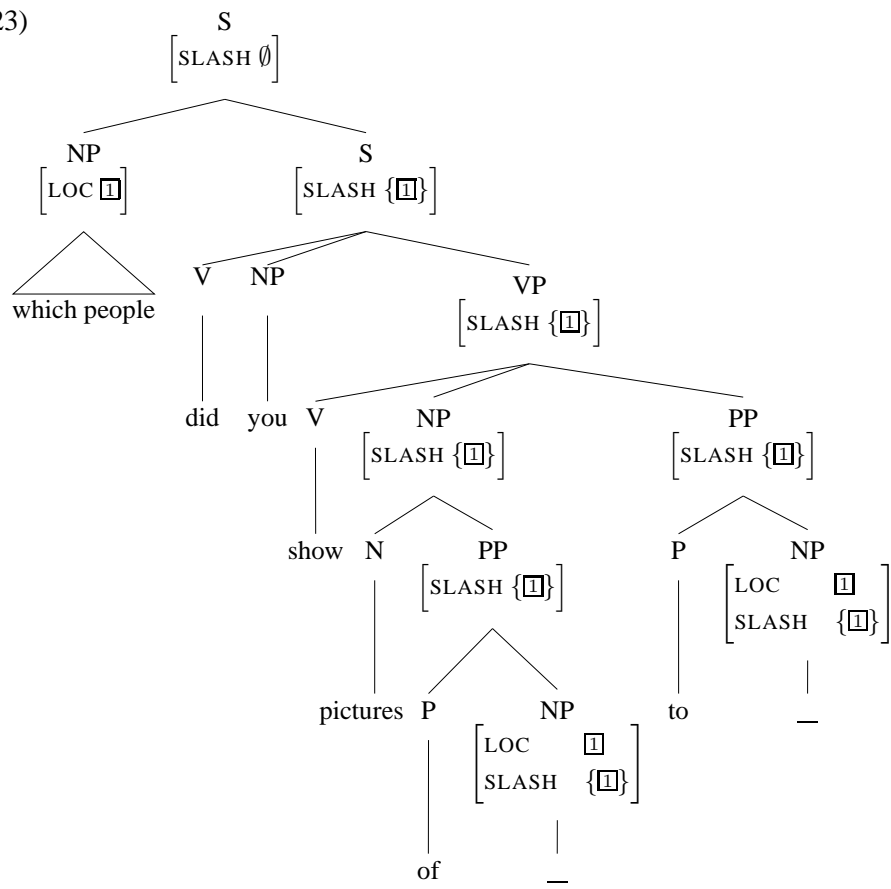

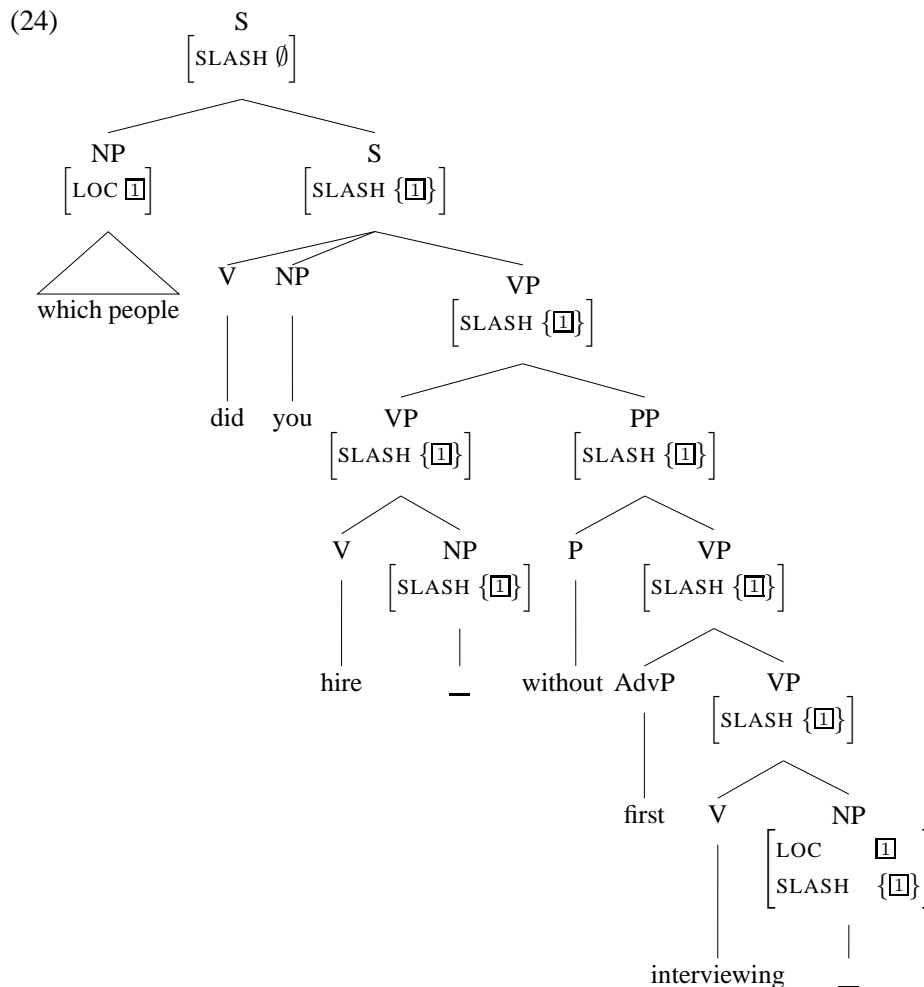

Very similar structures give rise to subject parasitic gaps, such as (25):

(25) Which of the candidates do you think my talking to $_i$ would bother $_i$?

3.2 A Reassessment of Symbiotic Gaps

Much of the literature on parasitic gaps in English has assumed that a gap within an adverbial phrase is on a par with one within a subject phrase in that both require the presence of another coindexed gap in order to be legitimate. Pollard and Sag (1994, Chapter 4) challenge this assumption, citing examples like the following, where extraction out of adverbials is possible without the presence of any additional gap performina a ‘licensing’ function:

- (26) a. That’s the symphony that Schubert died [without finishing $_$].
 b. Which room does Julius teach his class [in $_$]?

- c. Who did you go to Girona [in order to meet ___]?
- d. What kind of wagon did they used to ride to school [in ___]?
- e. How many of the book reports did the teacher smile [after reading ___]?
- f. This is the blanket that Rebecca refuses to sleep [without ___].

But if these examples are well-formed (as they certainly seem to be), then we need to rethink the ‘parasitic’ nature of examples like (10b), repeated here as (27b):

- (27) a. What kinds of books do authors of ___ argue about royalties after writing ___?
- b.??What kinds of books do authors of malicious pamphlets argue about royalties after writing ___?
- c.*What kinds of books do authors of ___ argue about royalties after writing malicious pamphlets?

In short, what seems empirically motivated is an approach to island phenomena that appeals to independent, partly extragrammatical factors that will explain why extraction out of adverbial phrases are sometimes of reduced acceptability. Moreover, one of the relevant factors is the presence of an overt direct object NP in the preceding VP. Controlling for this or other (only partly understood factors) restores full acceptability to the putative island-violating extractions:

- (28) a. What kinds of books do authors of malicious pamphlets get sick after writing ___?
- b. What kinds of books do authors of malicious pamphlets congratulate each other after writing ___?
- c. Which of our books did the authors get fi red after writing ___?

‘Parasitism’, at least in the case of gaps within adverbial phrases, is an illusion. We may thus delimit the scope of our account of parasitic gaps to deal with extractions out of subjects, which seems to be possible only if a gap appears in some subsequent constituent.⁶

⁶Some might argue further that extractions from subjects, even in the absence of a licensing ‘primary’ gap, are in principle grammatical:

- (i) (?)There are certain topics that jokes about ___ are completely unacceptable.
- (ii) (?)There are certain dignitaries that my jokes about ___ are always considered over the top.
- (iii) (?)There are certain dignitaries that my talking to ___ would be considered improper.

We want to emphasize that this assessment of the facts would simplify our grammar further, allowing even the constraint that we are about to introduce to be eliminated.

Pollard and Sag (1994, Chapter 4) propose a principle they call the Subject Condition:⁷

(29) Subject Condition:

The initial element of a lexical head's ARG-ST list may be slashed only if that list contains another slashed element.

This predicts the familiar contrast in (30):

- (30) a. *That was the rebel leader who rivals of __ assassinated the British consul.
 b. That was the rebel leader who rivals of __ assassinated __.

This is because only the ARG-ST list of the verb *assassinated* in (30b) satisfies (29). Similarly, the contrast between (31a) and (31b) is accounted for, as illustrated in (32):

- (31) a. *Who did my talking to __ bother Hilary?
 b. Who did my talking to __ bother __?

(32) Partial lexical entry for *assassinate* or *bother*:

$$\left[\text{ARG-ST} \left\langle \text{NP}_1, \text{NP}_2 \right\rangle \right]$$

The Subject Condition ensures that NP₁ can have a nonempty SLASH value just in case NP₂ also does.

And this approach immediately extends to explain the contrast between (27a,c) if we incorporate the 'adverbs as complements' analysis that has been proposed on entirely independent grounds by numerous researchers, including Bouma et al. 2001 and Przepiórkowski 1999. On this analysis, the ARG-ST of verbs is extended to include certain adverbials that are selected by the verb as though they were a complement. We will assume that this includes *after*-phrases, which we treat as a kind of PP. This leads to an ARG-ST list like the following as one possibility for the verb *argue*:

(33) Partial lexical entry for *argue* with extended ARG-ST list:

$$\left[\text{ARG-ST} \left\langle \text{NP}, \text{PP}_1, \text{PP}_2 \right\rangle \right]$$

The Subject Condition ensures that NP₁ can have a nonempty SLASH value just in case PP₁ or PP₂ also does. This accounts for the contrast between (27a,c), as well as correctly predicting the grammaticality of the following examples:

- (34) a. What kinds of books do authors of __ always argue about __ (after hours)?
 b. What kinds of books do authors of __ always argue about __ after finishing __?

⁷We have replaced Pollard and Sag's SUBCAT list with the feature ARGUMENT-STRUCTURE (ARG-ST). See Manning and Sag 1998.

3.3 The Case Conflict Conundrum Reconsidered

Since its inception, the phrase-structure theoretic approach to UDCs has assumed that the filler in parasitic gap constructions is linked by the same connectivity mechanism—the propagation of a SLASH feature—to all of the gaps that share its LOC specifications. And this assumption, taken together with an explicit proposal for the values of the feature CASE put forth by Levine et al. (2000), provides a resolution of the troublesome case conflict data discussed in the previous section (examples repeated here):

(35) Robin is someone who_i even good friends of ___i believe ___i likes power entirely too much.

(36) a. *He_i /*Him_i , even friends of ___i think ___i likes power entirely too much.

b. *Whom do even friends of ___i think ___i likes power entirely too much?

As Levine et al. show, the modeling assumptions of HPSG interact with lexical underspecification to predict exactly the observed contrasts. They assume that the case values form a semi-lattice structure like (37), where *p-nom* and *p-acc* stand for ‘pure’ nominative and accusative case, respectively:

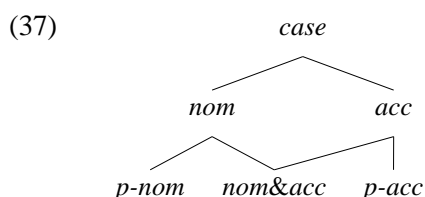

This assumes that there is a case value *nom&acc* that is compatible with both the constraints imposed by prepositions on their objects (that they be some subtype of *acc*) and those that finite verbs impose on their subjects (that they be some subtype of *nom*). Because a selector (verb, preposition, etc.) only bounds the CASE value of its argument(s) (rather than resolving it), the conflict in an example like (35) is only apparent. This is because various expressions, for example *who* and proper names, are lexically unspecified for case, and hence can be resolved to the *nom&acc* value in order to satisfy both selectional demands simultaneously. By contrast, the lexical entries for inflected nominals like *he*, *him*, and *whom* all include fully resolved case specifications: *p-nom*, *p-acc*, and *p-acc*, respectively. And since *p-nom* and *p-acc* are not only incompatible with each other, but also with the value *nom&acc*, there is no way to simultaneously satisfy the grammar’s constraints in examples like (36a,b). The constraint-based approach to UDCs thus provides a satisfying solution to the vexed problem of case conflict in parasitic gaps which, as we have seen, has stymied transformational approaches to UDCs.

3.4 Across-the-Board Extraction

Finally, let us now reconsider coordinate structures. All analyses of coordination must posit some identity condition holding between the mother and the daughters (the conjuncts) of a coordinate structure. This is often assumed to be a requirement of category identity, though the precise resolution of examples like (38), first analyzed by Sag et al. (1985), remains as a challenge to most current accounts:

- (38) a. Kim is a Republican and proud of it.
b. You can rely on our loyalty and that we will do everything in our power to protect you.

But any version of the identity condition is compatible with the constraint-based approach to extraction, as long as it includes the requirement that (in true conjoined structures) the SLASH value of the conjunct daughters must be identical. This requirement, taken together with the analysis of UDCs outlined above, provides an immediate account of the CSC/ATB contrasts considered earlier, repeated here:

- (39) a.*[Which dignitaries]_i do you think [[Sandy photographed the castle] and [Chris visited ___]]?
b.*[Which dignitaries]_i do you think [[Sandy photographed ___] and [Chris visited the castle]]?
c. [Which dignitaries]_i do you think [[Sandy photographed ___] and [Chris visited ___]]?
- (40) a.*[Which of her books]_i did you find both [[a review of Gould] and [a reply to ___]]?
b.*[Which of her books]_i did you find both [[a reply to ___] and [a review of Gould's new book]]?
c. [Which of her books]_i did you read both [[a review of ___] and [a reply to ___]]?

These contrasts are all straightforwardly derived from the the identity constraint on coordinate structures.⁸

⁸There is a further issue raised by the observation that gaps cannot be conjuncts:

(i)*[Which of her books]_i did you find both [[a review of ___] and [___]]?

(ii)*[Which of her books]_i did you find [[___] and [a review of ___]]?

(iii)*[Which rock legend]_i would it be ridiculous to compare [[___] and [___]]? (cf. [Which rock legend]_i would it be ridiculous to compare ___ with himself_i ?)

For further discussion, see Bouma et al. 2001 and Sag 2000, who account for such examples by eliminating *wh*-traces from their constraint-based analysis of UDCs.

4 Conclusion

We conclude with the following observations:

1. The HPSG theory of filler/gap UDCs takes the putative ‘true’ and the alleged ‘parasitic’ gaps to be completely on a par with one another. Hence the Kearney paradigm facts are predicted, given the binding theory of Pollard and Sag 1994 and processing constraints that are independently motivated by examples like (5) and (7).
2. The well-formedness of nominative subject p-gaps corresponds to the HPSG null hypothesis, and hence nothing further needs to be said about it.
3. The HPSG theory of p-gaps, since it treats all gaps on a par, can treat symbiotic gaps exactly the same as parasitic gaps, assuming the general position on strong islands taken in Pollard and Sag 1994 (and strongly supported by the complementary work of Kluender, Kroch and others). As noted, the Pollard-Sag Subject Condition, taken together with the ‘adverbs as complements’ analysis, predicts the well-formedness of the symbiotic gap examples we have discussed.
4. The case mismatch facts fall out simply and directly from the case type hierarchy presented in Levine et al. 2000. Nothing further needs to be said.
5. The Coordinate Structure Constraint and its ‘across-the-board’ exceptions also fall out directly from the independently motivated identity constraints on coordinate structures within the HPSG analysis of extraction. Movement-based alternatives have yet to be reconciled with these long-standing problematic data.

In short, none of the difficulties we have noted, which have been significant deficiencies in movement-based approaches to p-gaps throughout all the variants we have examined, ever arises in HPSG. The conclusion seems inevitable: on general methodological, as well as purely empirical grounds, HPSG provides a superior account of parasitic and, more generally, multiple gap constructions.

References

- Bouma, G., Malouf, R., and Sag, I. A.: 2001, Satisfying constraints on extraction and adjunction, *NLLT* 19, 1–65
- Chomsky, N.: 1982, *Concepts and Consequences of the Theory of Government and Binding*, Cambridge, MA: MIT Press
- Chomsky, N.: 1986, *Barriers*, Cambridge, MA: MIT Press
- Cinque, G.: 1990, *Types of \bar{A} -dependencies*, Cambridge, MA: MIT Press
- Frampton, J.: 1990, Parasitic gaps and the theory of *wh*-chains, *Linguistic Inquiry* 21, 49–77

- Gazdar, G.: 1981, Unbounded dependencies and coordinate structure, *Linguistic Inquiry* 12, 155–84
- Gazdar, G., Klein, E., Pullum, G. K., and Sag, I. A.: 1985, *Generalized Phrase Structure Grammar*, Oxford: Basil Blackwell's and Cambridge, MA: Harvard University Press
- Gazdar, G., Pullum, G. K., Sag, I. A., and Wasow, T.: 1982, Coordination and Transformational Grammar, *Linguistic Inquiry* 13.4, 663–677
- Haegeman, L.: 1984, Parasitic gaps and adverbial clauses, *Journal of Linguistics* 20, 229–232
- Kearney, K.: 1983, *Governing categories*, Unpublished ms. University of Connecticut, Storrs, CT.
- Kehler, A.: 2002, *Coherence, Reference and the Theory of Grammar*, Stanford: Center for the Study of Language and Information
- Levine, R. D.: 2001, The extraction riddle: just what are we missing?, *Journal of Linguistics* 37, 145–174
- Levine, R. D., Hukari, T. E., and Calcagno, M.: 2000, Some overlooked parasitic gap constructions in English and their theoretical implications, in P. Culicover and P. M. Postal (eds.), *Parasitic Gaps*, pp 181–222, Cambridge, MA: MIT Press
- Levine, R. D. and Sag, I. A.: 2003, WH-nonmovement, *Gengo Kenkyu: Journal of the Linguistic Society of Japan* 123, 171–219
- Longobardi, G.: 1984, Connectedness and island constraints, in J. Gueron, H.-G. Obernauer, and J.-Y. Pollock (eds.), *Grammatical Representation*, pp 161–185, Dordrecht: Foris
- Manning, C. and Sag, I. A.: 1998, Argument structure, valence, and binding, *Nordic Journal of Linguistics* 21, 107–144
- Pollard, C. J. and Sag, I. A.: 1992, Anaphors in English and the scope of binding theory, *Linguistic Inquiry* 23.2
- Pollard, C. J. and Sag, I. A.: 1994, *Head-Driven Phrase Structure Grammar*, Chicago: University of Chicago Press and Stanford: CSLI Publications
- Postal, P. M.: 1998, *Three Investigations of Extraction*, Cambridge, MA: MIT Press
- Przepiórkowski, A.: 1999, *Case Assignment and the Complement-Adjunct Dichotomy: A non-Configurational Constraint-Based Approach*, Ph.D. thesis, Universität Tübingen
- Reinhart, T. and Reuland, E.: 1993, Reflexivity, *Linguistic Inquiry* 24, 657–720
- Ross, J. R.: 1967, *Constraints on Variables in Syntax*, Ph.D. thesis, MIT, Published in 1986 as *Infinite Syntax!*. Norwood, N. J.: Ablex
- Sag, I. A.: 1997, English relative clause constructions, *Journal of Linguistics* 33, 431–484
- Sag, I. A.: 2000, Another argument against *wh*-trace, *Jorge Hankamer Webfest*: <http://ling.ucsc.edu/Jorge/>
- Sag, I. A., Gazdar, G., Wasow, T., and Weisler, S.: 1985, Coordination and how to distinguish categories, *Natural Language and Linguistic Theory* 3, 117–171

Non-transitive information flow in Japanese noun-classifier matching

Roger Levy 

Stanford University

David Yoshikazu Oshima 

Stanford University

Proceedings of the 10th International Conference on
Head-Driven Phrase Structure Grammar

Michigan State University

Stefan Müller (Editor)

2003

Stanford, CA: CSLI Publications

pages 257–277

Levy, Roger & David Yoshikazu Oshima. 2003. Non-transitive information flow in Japanese noun-classifier matching. In Stefan Müller (ed.), *Proceedings of the 10th International Conference on Head-Driven Phrase Structure Grammar, Michigan State University*, 257–277. Stanford, CA: CSLI Publications. DOI: 10.21248/hpsg.2003.15.



Abstract

In Japanese, as in other classifier languages like Chinese and Malay, numerals do not directly quantize nouns, but first combine with a classifier to form a *measure phrase* (MP; cf. Aikhenvald 2000). From the perspective of constraint-based approaches to syntax/semantics, the mutual selective restriction between classifiers and nouns can be stated in terms of information-sharing and featural identity, to some extent parallel to the treatment of gender/number agreement (between determiner and noun, for instance) (cf. Pollard and Sag 1994; Kathol 1999). There are, however, data that challenge this line of approach to noun-classifier matching. We demonstrate in this paper that it is possible that a single noun is associated with different types of classifier, and show why they are problematic for unification-based approaches, similar to the situation with case syncretism in European languages (Ingria 1990 and others). Later in the paper, we argue that information-sharing between noun, predicate and classifier is not completely transitive, and present a formal analysis which models multiple selectional requirements with sets.

1 Introduction

The long-standing problem of *polysemy* in natural language gained new importance with the advent of generative grammar. Whether two aspects of the meaning of a phonological string were simply pure homophony or rather different facets of a unified representation was no longer a pedantic issue; in transformational syntax it determined whether conditions were met for a variety of transformations covering ellipsis, pronominalization, conjunction, and relativization. Within constraint-based syntax the issue has not disappeared, but rather has broadened to include purely formal cases of phonological identity, called *syncretism* (Zaenen and Karttunen, 1984; Pullum and Zwicky, 1986). A variety of cases involving government or concord with syncretic items leads to the difficulty in a number of constraint-based theories that information sharing becomes *non-transitive*: if, for example verb A governs case X, verb B governs case Y, and noun N can be simultaneously governed by both verb A and verb B, it does not follow that X=Y. Similar cases in more semantic domains have also been identified; for example, one instance of the name of an author may be simultaneously be used to identify an individual in a matrix clause and that individual's literary output in a relative clause. These observations have stimulated a variety of approaches, ranging from the more pragmatically-based (Nunberg, 1979) to formal analyses more closely resembling treatments of syncretism (Pustejovsky, 1995).

In this paper we show that the same issues of polysemy arise in a superficially different domain, that of noun classifiers in Japanese. It is possible to use two distinct classifiers simultaneously to measure over a single noun, subject to an interacting host of syntactic and semantic constraints. We investigate the syntax and semantics of Japanese noun-classifier matching, showing how the problems and treatments of polysemy and syncretism apply. A major conclusion of this work is that in some cases, the semantic dimensions of measurement corresponding to

different classifiers for a single noun must be hierarchically organized, a result that can be shown much more clearly in Japanese than the syntax of a language like English would allow.

2 Basic facts

2.1 Syntax/semantics of measure phrases

In this section we briefly review the internal and external syntax of classifiers and measure phrases. A basic measure phrase consists internally of a numeral quantity followed immediately by a classifier:

- (1) *3-nin* *5-hiki* *7-satu* *9-mai*
 3-CL.human 5-CL.animal 7-CL.bound_object 9-CL.2D_object

Certain quantity modifiers optionally follow the classifier, as in *2-hiki-zutu* ‘two-CL.animal each’, but these modifiers play no role in our analysis.

Following Gunji and Hasida (1998), we identify three distinct external environments where measure phrases occur: prenominal, postnominal, and adverbial, as seen in (2).

- (2) ‘Three monkeys came’
- a. *3-biki-no* *saru-ga* *ki-ta.* (prenominal)
 3-CL.animal-Gen monkey-Nom come-Past
- b. *Saru* *3-biki-ga* *ki-ta.* (postnominal)
 monkey 3-CL.animal-Nom come-Past
- c. *Saru-ga* *3-biki* *ki-ta.* (adverbial)
 monkey-Nom 3-CL.animal come-Past

Both the prenominal and postnominal MPs can have either distributive or non-distributive readings, and generally seem to have little difference in their semantic import. In this paper we frequently group these two types as “intranominal”. Adverbial MPs (so-called ‘floating quantifiers’), in contrast, must be associated with either themes or agents and measure the extent of participation in the event denoted by the verb.¹

- (3) a. *3-nin-no* *gakusei-ga* *piano-o* *motiage-ta.*
 3-CL.human-Gen student-Nom piano-Acc lift-Past
 ‘Three students lifted a piano.’ (both the distributive and collective readings possible)
- b. *Gakusei-ga* *3-nin* *piano-o* *motiage-ta.*
 student-Nom 3-CL.human piano-Acc lift-Past
 ‘Three students lifted a piano.’ (the distributive reading only)

¹This is a slightly simpler stance than is taken by Gunji and Hasida (1998), who claim that adverbial MPs are strictly quantificational when associated with agents.

2.2 Multiple measuring

Semantically, the application of a measure phrase to a noun involves the *measurement* of the denotatum of the noun in dimensions roughly specified by the classifier. Since most denotata can potentially be measured in more than one dimension, there is generally more than one classifier applicable to a single noun. For example, ‘beer’ in Japanese can be measured with classifiers *meigara* ‘brand’, *syurui* ‘kind’, or any of a variety of volume-measuring classifiers, such as *garon* ‘gallon’ and *rittoru* ‘liter’. (See Denny 1979; Downing 1996; Iida 2000; Paik and Bond 2002 for classifier taxonomies.)

Not only can a single noun be measured by more than one type of classifiers, in some cases a single noun token can be simultaneously measured by multiple classifiers. Multiple measuring of a single noun token can be classified into two types, depending on the type of the relation between classifiers: (i) type/token and (ii) alternative units on a single dimension:

(4) type-token

- a. 3-syurui-no sakana-o 2-hiki-zutu tabe-ta.
3-CL.species-Gen fish-Acc 2-CL.animal-each eat-Past
‘(I) ate two each of three species of fish.’
- b. 2-satu-no hon-o gookei 10,000-bu zoosatu-si-ta.
2-CL.bound_object-Gen book-Acc in.total 10,000-CL.copy print-Past
‘(The publisher) printed a total 10,000 copies of two books.’
- c. 3-meigara-no biiru 2-syurui-zutu-o gookei 10-garon non-da.
3-CL.brand-Gen beer 2-CL.species-Acc in.total 10-CL.gallon drink-Past
‘(We) drank two types each of three brands of beer, ten gallons in total.’

The type/token classifier relationship is reminiscent of but distinct from the well-known species/individual distinction in formal semantics (Carlson 1977 and others). We are concerned here with a *relationship* between classifiers: two classifiers are in a type/token relationship if the latter classifier measures units within a set of categories delimited by the former. This is clear in (4c), where kinds of beer (*syurui*) are tokens of different brands of beer (*meigara*), and gallons of beer (*garon*) are in turn tokens (albeit continuous rather than discrete) of different kinds of beer (*syurui*).

(5) alternative units

- a. Mizu-o 3-bai, zenbu-de 2-rittoru non-da.
water-Acc 3-CL.cup in.total 2-CL.liter drink-Past
‘(I) drank three glasses of water, two liters in total.’
- b. Hon-o 5-hako, (gookei) 100-satu hakon-da.
book-Acc 5-CL.box in.sum 100-CL.bound_object transport-Past
‘(I) moved five boxes of books, 100 books in total.’

Example (5) above illustrates cases of multiple measurements in a single dimension – volume in (5a), and physical quantity in (5b).

In cases of two distinct classifiers for a given noun in a single clause, there

are twelve logically possible combinations of environment and intra-environment linear order for the two classifiers. Four are ruled out, however, by the fact that Japanese syntax does not allow more than one prenominal MP or more than one postnominal MP in a single noun phrase. There also turn out to be further constraints on classifier positioning which we outline below; these are based on semantic considerations, and we take them up in the remainder of the paper.

Type-token classifier pairs permit the following arrangements: prenominal type plus postnominal token; adverbial type and adverbial token; or intranominal (either pre- or post-nominal) type plus adverbial token. These arrangements are exemplified in (6)-(8).

(6) intranominal/intranominal²

- a. 2-syurui-no sakana 3-biki-zutu-o tabe-ta.
 2-CL.species-Gen fish 3-CL.animal-each-Acc eat-Past
 'I ate three each of two species of fish.'
- b. *3-biki(-zutu)-no sakana 2-syurui-o tabe-ta.
 3-CL.animal(-each)-Gen fish 2-CL.species-Acc eat-Past

(7) adverbial/adverbial

- a. Sakana-o 2-syurui, gookei 10-piki tabe-ta.
 fish-Acc 2-CL.species in.total 10-CL.animal eat-Past
 'I ate two species of fish, ten fish in all.'
- b. ?Sakana-o gookei 10-piki, 2-syurui tabe-ta.
 fish-Acc in.total 10-CL.animal 2-CL.species eat-Past

(8) intranominal/adverbial

- a. (i) 2-syurui-no sakana-o gookei 10-piki tabe-ta.
 2-CL.species-Gen fish-Acc in.total 10-CL.animal eat-Past
 'I ate a total of ten of two species of fish.'
- (ii) Sakana 2-syurui-o gookei 10-piki tabe-ta.
 fish 2-CL.species-Acc in.total 10-CL.animal eat-Past
 'I ate a total of ten of two species of fish.'
- b. (i) *(Gookei) 10-piki-no sakana-o 2-syurui tabe-ta.
 in.total 10-CL.animal-Gen fish-Acc 2-CL.species eat-Past
- (ii) *Sakana (gookei) 10-piki-o 2-syurui tabe-ta.
 fish in.total 10-CL.animal-Acc 2-CL.species eat-Past

Alternative-unit combinations permit only multiple intranominal or multiple adverbial uses. These are illustrated in (9)-(11).

(9) intranominal/intranominal

- a. 3-hako-no hon 100-satu-o hakon-da.
 3-CL.box-Gen book 100-CL.bound_object-Acc transport-Past
 '(I) moved three boxes of books, 100 books in all.'

²Some speakers do not accept multiple intranominal classifiers. As noted in the text above, we have found no speakers who accept more than one prenominal or more than one postnominal classifier in a single NP.

- b. ?100-satu-no hon 3-hako-o hakon-da.
 100-CL.bound_object-Gen book 3-CL.box-Acc transport-Past
 ‘(I) moved three boxes of books, 100 books in all.’³
- (10) adverbial/adverbial
- a. Hon-o 3-hako, gookei 100-satu hakon-da.
 book-Acc 3-CL.box in.total 100-CL.bound_object transport-Past
 ‘(I) moved three boxes of books, 100 books in all.’
- b. (?)Hon-o gookei 100-satu, 3-hako hakon-da.
 book-Acc in.total 100-CL.bound_object 3-CL.box transport-Past
 ‘(I) moved three boxes of books, 100 books in all.’
- (11) intranominal/adverbial
- a. (i) *3-hako-no hon-o 100-satu hakon-da.
 3-CL.box-Gen book-Acc 100-CL.bound_object transport-Past
 (ii) *Hon 3-hako-o 100-satu hakon-da.
 book 3-CL.box-Acc 100-CL.bound_object transport-Past
- b. (i) *100-satu-no hon-o 3-hako hakon-da.⁴
 100-CL.bound_object-Gen book-Acc 3-CL.box transport-Past
 (ii) *Hon 100-satu-o 3-hako hakon-da.
 book 100-CL.bound_object-Acc 3-CL.box transport-Past

We can generalize the pattern of type-token multiple classifier arrangement more succinctly by taking advantage of the fact that the three possible measure phrase environments are totally ordered with respect to their *syntactic proximity* to the noun. Syntactic proximity has an intuitive explanation in terms of context-free trees as follows: Node A is closer than node B to node X iff the shortest path between B and X (not including B and X themselves) contains all the nodes in the shortest path from A to X, but not vice versa. Adverbial MPs are clearly farther than intranominal MPs from the modified noun; furthermore, constituency test by coordination confirms that prenominal MPs are closer to the noun than are postnominal MPs (‘corr’ is units of correspondence for letters):

- (12) a. 20-tuu-no tegami-to 3-saku-no syoosetu 2,000-mai-o
 20-CL.corr-Gen letter-Conj 3-CL.work-Gen novel 2,000-page-Acc
 kai-ta.
 write-Past
 ‘(I) wrote 2,000 pages’ worth of twenty letters and three novels.’
- b. *6-syurui-no sakana 7-hiki-to tori 7-wa-o
 6-CL.species-Gen fish 7-CL.ind.animal-Conj bird 7-CL.ind.bird-Acc
 tabeta.
 eat-Past
 ((I) ate five types of fish and bird, seven fish and seven birds.)

³There may be another, marginal reading of (9b) that involves three cases of 100 books each. This reading is discussed in Section 4.2.

⁴Example (11bi) also has another reading involving at least three hundred books. It will be discussed later.

The configuration of the three MP environments thus looks as follows:⁵

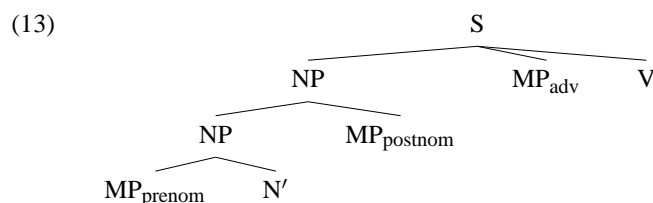

From the data above we can thus make the following generalizations about possible multiple-classifier arrangements in a single clause:

- (14) in the “type-token” case:
- a. The type MP must be at least as syntactically close to the measured as the token MP.
 - b. For multiple adverbial classifiers, it is preferred that the linear order of MPs conforms the order: type > token.
- (15) in the “alternative units” case:
- a. The intranominal/adverbial combination is impossible.
 - b. Two intranominal classifiers are possible; it is preferred for the larger unit to occupy the (syntactically closer) prenominal position, and for the smaller unit to be postnominal.
 - c. The effect of linear order (bigger unit preceding smaller unit) for multiple adverbial classifiers is weaker than that of type preceding token, if not absent.

The next two sections of the paper will focus on the type-token case, which exhibits the clearest asymmetries of felicity judgements. We develop a constraint-based analysis of Japanese noun-classifier matching, properly capturing the syntactic-semantic relationships between noun, measure phrase, and verbs, which allows for multiple matchings and correctly predicts the asymmetries shown above. In Section 4.2 we briefly return to the issue of non-canonical arrangements of alternative-unit classifier combinations. The linear order asymmetry for type/token adverbial classifier pairs seems to us less categorical, and we leave its status as an open question.

3 Analysis

Our first task is to clarify our position on the syntactic versus semantic nature of noun-classifier concord in Japanese. In general there is strong semantic motivation for noun classification (Matsumoto, 1993; Iida, 2000), but we will take a somewhat vague and weak position on the syntactic versus semantic nature of noun classification as our main goal is to elucidate the interaction of varying dimensions of

⁵We do not take a strong position about the identity of categories labeled S and NP in (13); we use S on the assumption that Japanese clause is flat and has no VP.

measurement with Japanese syntax. We assume that an utterance of a noun (or a pronoun, overt or null) is associated with a *cognitive object*, which is *measurable* in a variety of dimensions. For a given type of cognitive object there is a one-to-one mapping between the set of measurable dimensions for the object and the set of classifiers compatible with the object.⁶ The use of a particular classifier in an MP for a given noun invokes the dimension along which the cognitive object associated with the noun is measured. As we have seen, a cognitive object can be measurable in multiple dimensions in a single utterance.

3.1 Case syncretism and a set-based approach to noun-classifier matching

As stated thus far, the problem of multiple measurement is isomorphic to the (strictly formal) problem of case syncretism in European languages, where a single noun token may satisfy multiple distinct case requirements (Ingria, 1990; Bayer and Johnson, 1995; Bayer, 1996; Blevins, 2003; Dalrymple and Kaplan, 2000; Levy, 2001; Levy and Pollard, 2001; Daniels, 2001; Sag, 2002). Example (16) below illustrates the problem of case syncretism, where the syncretized noun *Frauen* ‘women’ satisfies both accusative and dative requirements.⁷

- (16) Er findet und hilft Frauen.
 He finds.Acc and helps.Dat women.Acc/Dat
 ‘He finds and helps women.’

Most formal treatments of case syncretism treat the simpler instances with what is essentially a set-structured account, making a noun’s case value a set and treating case government as a membership requirement (see Dalrymple and Kaplan 2000 for the clearest implementation of this idea):

- (17) *Frauen* ‘women’: CASE = {ACC,DAT}
finden ‘find’: requires ACC ∈ CASE of its object
helfen ‘help’: requires DAT ∈ CASE of its object

In the case of Japanese classifiers, the issue is that a single noun can be measured by multiple classifiers. Like the syncretism problem, the classifier problem is amenable to a set-based analysis:

- (18) classifier type (CLTYPE) specification for *hon* ‘book:

$$\left[\text{CLTYPE} \left\{ \text{COPY, BOUND_OBJECT, } \dots \right\} \right]$$

A classifier measuring a noun can be thought of as imposing a membership requirement on the CLTYPE value of the measured noun. Membership requirements

⁶We are *not* making a claim that there is a one-to-one mapping from classifiers to specific dimensions of cognitive objects in the language.

⁷*Frauen* is actually syncretized for all German cases, but we include only accusative and dative for narrative simplicity.

can also be formulated as non-empty intersection constraints on singleton CLTYPE values; we use that formulation in the remainder of the paper.

- (19) a. 1-piki-no
 1-CL.ind_animal-GEN: {IND_ANML}
 sakana
 fish: {IND_ANML, MASS_FOOD, SPECIES, ... }
 $\{IND_ANML\} \cap \{IND_ANML, MASS_FOOD, SPECIES, \dots\} \neq \emptyset$
- b. *1-wa-no sakana
 1-CL.ind_bird-GEN: {IND_BIRD} fish: {IND_ANML, SPECIES, ... }
 $\{IND_BIRD\} \cap \{IND_ANML, SPECIES, \dots\} = \emptyset$

This analysis captures the non-transitive requirement of multiple classifiers to match the noun: each classifier individually needs to match the noun, but this does *not* mean that the classifiers must match each other, as shown below in (20).

- (20) Tegami-o 2-tuu, gookei
 letter-Acc: {CORR, 2D_OBJECT, ... } 2-CL.corr: {CORR}, in.sum
 10-mai kai-ta.
 10-CL.2D_object: {2D_OBJECT} write-Past
 $\{CORR, 2D_OBJECT, \dots\} \cap \{CORR\} \neq \emptyset$
 $\{CORR, 2D_OBJECT, \dots\} \cap \{2D_OBJECT\} \neq \emptyset$

3.2 Adverbial measure phrases and verbs as classification filters

The distribution of classifiers is not, however, determined only by the compatibility of nouns with classifiers. In particular, the governing verb acts as a *filter* on the compatibility of classifiers. The intuitive explanation for this is that an event denoted by a verb involves the participation of at least one aspect (measurable dimension) of each of its arguments, and some events pick out only a limited set of aspects of their cognitive objects valid for participation. An adverbial classifier is associated with the event denoted by the verb with which it is syntactically associated; it therefore can measure only in those dimensions of the associated argument which can validly participate in the event. (We take up the case of intransitive classifiers in Section 3.3.) We see this in (21)-(22) below, where the verb *kuguru* ‘pass through’ is incompatible with the ‘flat object’ aspect of a window picked out by the classifier *mai*, and the verb *makikomareru* ‘get involved in’ is incompatible with the ‘scheduled event’ aspect of a bus picked out by *hon*.

- (21) a. Mado-o 1-tu/*mai kugut-ta.
 window-Acc 1-CL.general/CL.2D_object pass.through-Past
 ‘(I/you/he) went through a window.’
- b. Mado-ga 1-??tu/mai ware-ta.
 window-Acc 1-CL.general/CL.2D_object break_{intr}-Past
 ‘A window has broken.’

- (22) a. Basu-ga 1-dai/*pon ziko-ni
 bus-Nom 1-CL.vehicle/CL.scheduled_event accident-Dat
 makikom-are-ta.
 involve.in-Pass-Past
 ‘A bus was involved in a traffic accident.’
- b. Basu-o 1-?dai/pon nogasi-ta.
 bus-Acc 1-CL.vehicle/CL.scheduled_event miss-Past
 ‘(I) missed a bus.’

When there is more than one verb involved, an adverbial classifier need be compatible only with the verb with which it is syntactically and semantically associated, and with the noun it measures. In (23c), the verb *eigaka-sare-ta* ‘was made into a movie’ is incompatible with the ‘copy’ aspect of a book picked out by the classifier *bu*, but the presence of the verb in a relative clause does not prevent the appearance of *bu* as an adverbial classifier in the matrix clause, associated with another verb.

- (23) a. Hon-o 2-satu/*bu eigaka-sita.
 book-Acc 2-CL.bound_object/*CL.copy make.into.movie-PAST
 ‘(They) made two books into movies.’
- b. Hon-o 2,000-satu/bu zoosatu-sita.
 book-Acc 2,000-CL.bound_object/CL.copy print-PAST
 ‘(They) printed two thousand books (resp. bound_objects or copies)’
- c. Sono syuppansha-wa [eigaka-s-are-ta]
 that publisher-Top [make.into.movie-Pass-Past]
 hon-o 2,000-bu zoosatu-sita.
 2-CL.bound_object-Gen book-Acc 2,000-CL.copy print-PAST
 ‘That publisher printed 2,000 (additional) copies of books made into movies.’
- (24) Mado-o 3-tu kugut-te, 2-mai wat-ta.
 Window-Acc 3-CL.general passthrough-Conj, 2-CL.2D_object break_{trans}-Past
 ‘(I) went through three windows and broke two.’

We formalize the filtering effect of a verb with the notion of *set intersection* between the CLTYPE set of the noun and the (argument-specific) set of *allowed* classifiers for the governing verb.

- (25) a. Once again, classifier type (CLTYPE) specification for *hon* ‘book’:

$$\left[\text{CLTYPE } \boxplus \{ \text{COPY, BOUND_OBJECT, } \dots \} \right]$$
- b. Allowed classifier type specification for object of *eigaka-suru* ‘make into a movie’:

$$\left[\text{CLTYPE } \boxtimes \{ \text{BOUND_OBJECT, } \dots \} \right]$$
- c. Resulting set of allowed adverbial classifiers for *hon-o eigaka-suru* ‘make a book into a movie’:

$$\left[\text{CLTYPE } \boxplus \cap \boxtimes = \{ \text{BOUND_OBJECT} \} \right]$$
- d. For objects of *zoosatu-suru* ‘print’, the allowed classifier type specification includes both BOUND_OBJECT and COPY, so either adverbial classifier in (23b) is allowed.

In this example, a different filtered CLTYPE value must be represented for each verb. Therefore a *relation* must be specified between the CLTYPE value of a nominal argument and its filtered CLTYPE value as an argument of a particular verb. The controversial ARG-STR feature can be a means of doing this: we assume that the representation on the relevant subcategorization list (COMPS or SUBJ in recent versions of HPSG) contains the nominal argument itself, and in the ARG-STR representation of the corresponding argument, the intersection with the verb's set of acceptable dimensions is substituted.⁸ This is shown in (26) for the verb *eigaka-suru* 'make into a movie'.

- (26) Partial lexical entry for *eigaka-suru* 'make into a movie':
- $$\left[\begin{array}{l} \text{COMPS} \left\langle \dots, \left[\text{CLTYPE } \boxed{1} \right], \dots \right\rangle \\ \text{ARG-STR} \left\langle \dots, \left[\text{CLTYPE } \boxed{1} \cap \{ \text{BOUND_OBJECT} \} \right], \dots \right\rangle \end{array} \right]$$

Adverbial measure phrases then interact with the filtered CLTYPE value for the noun they measure over:

- (27) Adverbial MP Modification Rule
- $$\left[\begin{array}{l} \text{ARG-STR} \left\langle \dots, \left[\begin{array}{l} \text{INDEX } \boxed{5} \\ \text{CLTYPE } \boxed{1} \end{array} \right], \dots \right\rangle \\ \text{RESTR } \boxed{2} \cup \left\{ \left[\begin{array}{l} \text{INDEX } \boxed{5} \\ \text{NUM } \boxed{3} \\ \text{UNIT } \boxed{6} \\ \text{CLTYPE } \boxed{1} \cap \boxed{4} \end{array} \right] \right\} \end{array} \right]$$
- $$\begin{array}{cc} \text{MP} & \text{V} \\ \left[\text{RESTR } \left[\begin{array}{l} \text{NUM } \boxed{3} \\ \text{UNIT } \boxed{6} \\ \text{CLTYPE } \boxed{4} \end{array} \right] \right] & \left[\text{RESTR } \boxed{2} \right] \end{array}$$

Example (28) and Figure 1 show the differential filtering of measurable aspects of the noun *hon* 'book' by the relative clause and matrix clause verbs. Note that the basic set of classifiable dimensions in CLTYPE of *hon*, marked as 1, does not directly interact with the adverbial classifiers that modify it; instead, the matrix and relative clause verbs hold a restricted set of available dimensions in their ARG-STR representation of *hon*, which interact with the adverbial classifiers.

⁸There are at least two other reasonable alternatives to resorting to ARG-STR on phrases here. One would be to directly match the adverbial MP with the semantic representation of the measured argument on the verbal projection. Another would be to let the verb take the adverbial MP as a complement via a lexical rule, and specify the required CLTYPE relationship between the classified argument and the MP in the lexical rule.

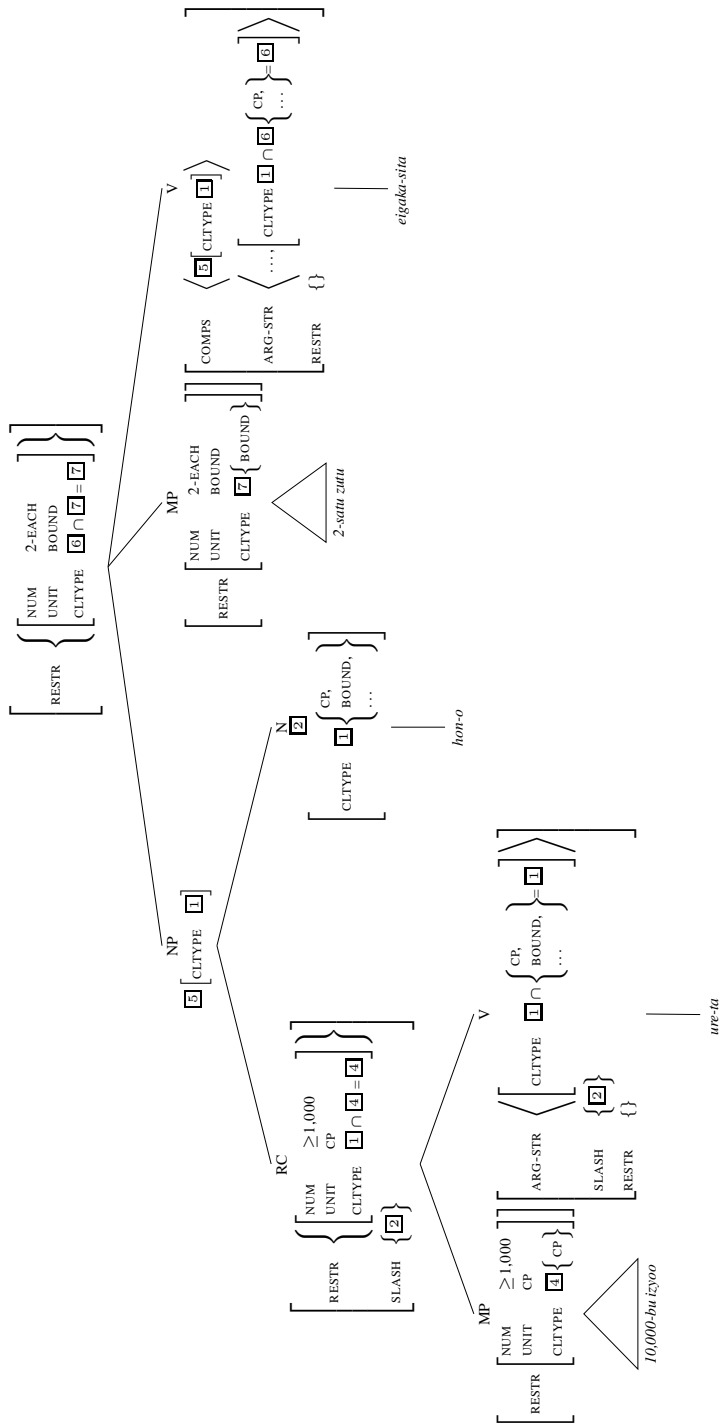

Figure 1: Analysis of Example (28)

- (28) [10,000-bu izyoo ure-ta] hon-o 2-satu
 [10,000-CL.copy above sell_{intr}-Past] book-Acc 2-CL.bound_object
 eigaka-sita.
 make.into.movie-Past
 ‘(I) made into movies two books that sold more than 10,000 copies.’

3.3 Intranominal measure phrases

The previous section has given us an understanding of the interaction of adverbial classifiers with NP and verb syntax and semantics. In this section we address intranominal classifiers. We begin by illustrating two crucial facts for our analysis.

First, in type-token multiple classifier cases involving an intranominal classifier, the type classifier must be syntactically at least as close to the noun as the token classifier (cf. (14a)). This is illustrated below:

- (29) (=6)
- a. 2-syurui-no sakana 3-biki-zutu-o tabe-ta.
 2-CL.species-Gen fish 3-CL.animal-each-Acc eat-Past
 ‘(I) ate three each of two types of fish.’
- b. *3-biki(-zutu)-no sakana 2-syurui-o tabe-ta.
 3-CL.animal(-each)-Gen fish 2-CL.species-Acc eat-Past
- (30) (=8)
- a. (i) 2-syurui-no sakana-o gookei 10-piki tabe-ta.
 2-CL.species-Gen fish-Acc in.total 10-CL.animal eat-Past
 (ii) Sakana 2-syurui-o gookei 10-piki tabe-ta.
 fish 2-CL.species-Acc in.total 10-CL.animal eat-Past
- b. (i) *(Gookei) 10-piki-no sakana-o 2-syurui tabe-ta.
 in.total 10-CL.animal-Gen fish-Acc 2-CL.species eat-Past
 (ii) *Sakana (gookei) 10-piki-o 2-syurui tabe-ta.
 fish in.total 10-CL.animal-Acc 2-CL.species eat-Past

The classifiers *syurui* (species) and *hiki* (animal) stand in a type-token relationship. The two may cooccur as adverbial classifiers, which are of equal syntactic distance from the noun, but if at least one is an intranominal classifier, then the type classifier *syurui* must be closer than the token classifier *hiki* to the noun. (Recall that both prenominal and postnominal classifiers are closer than adverbial classifiers to the noun, and prenominal are closer than postnominal.)

The second crucial fact is that nouns premodified by both measure phrases and relative clauses may have their interpretation and felicity affected by the relative ordering of premodifiers. In particular, a prenominal MP *between* a relative clause and the noun must be compatible with the verb in the relative clause governing the relativized noun, as well as with the noun’s external governing verb. A prenominal MP *preceding* a relative clause, however, need only be compatible with the external governing verb.⁹ This is illustrated in (31) below:

⁹As far as we know, a verb in a relative clause never restricts the occurrence of a postnominal

- (31) a. 1,000-bu-no eigaka-s-are-ta hon-o moyasi-ta.
 1,000-CL.copy-Gen make.into.movie-Pass-Past book-Acc burn_{trans}-Past
 ‘(I) burned 1,000 copies of books that were made into movies.’
- b. ?*Eigaka-s-are-ta 1,000-bu-no hon-o moyasi-ta.¹⁰
 make.into.movie-Pass-Past 1,000-CL.copy-Gen book-Acc burn_{trans}-Past
- c. Eigaka-s-are-ta 2-satu-no hon-o (gookei
 make.into.movie-Pass-Past 2-CL.bound-Gen book-Acc (in_total
 1,000-bu) moyasi-ta.
 1,000-CL.copy) burn_{trans}-Past
 ‘I burned (1,000 total copies of) two books that were made into movies.’

We put forth the following pretheoretical explanation for the type-token measure phrase placement asymmetry, based on what we take as the way humans intuitively conceptualize types and tokens. If an object is quantifiable on two dimensions that are in a type-token relationship (such as species-individual), a specified quantity of *tokens* implies a concrete, even if unspecified, quantity of associated types. A specified quantity of *types*, on the other hand, does not presuppose any quantization by token. This is probably most clearly seen in the basic case of kinds, such as species, discussed by Carlson (1977) and others: *three fish* implies a certain number of species of fish (three or less), but *three species of fish* implies nothing about a particular number of fish. This is also consistent with the asymmetry in predicate type, that there are kind-specific predicates such as *go extinct*, which are incompatible with individual-level NPs, but there seem to be no individual-specific predicates incompatible with all kind-level NPs.¹¹

It seems, then, that an intranominal MP sets up a cognitive object, quantified on a particular dimension determined by the MP’s classifier, that has a certain independence from any particular predicate with which the NP may be associated. This is quite unlike adverbial MPs, which measure the extent of participation of the quantified argument in a predicate-specific event. An adverbial MP modifying an NP with an intranominal MP can only quantify on dimensions that are neither explicitly nor implicitly specified by the quantification of the intranominal MP. Since a type classifier specifies nothing explicitly or implicitly about a quantity of tokens, a token MP may adverbially modify an NP with an intranominal type MP, but not vice versa, as we saw in (8).

The independence of cognitive objects set up by intranominal MPs also ex-

MP:

[Eigaka-s-are-ta] hon 1,000-bu-o moyasi-ta.
 [make.into.movie-Pass-Past] book 1,000-CL.bound-Acc burn_{trans}-Past
 ‘(I) burned 1,000 copies of books that were made into movies.’

¹⁰We also predict a grammatical reading of (31b), as will be seen momentarily.

¹¹Note that we are *not* claiming that any individual-oriented predicate can be used with any kind-level NP. At the least, definite singular NPs are not compatible with a kind interpretation when used with an individual-oriented predicate: *The spotted hyena ate my chickens* is about an individual spotted hyena, not about the kind *the spotted hyena*. But *N kinds of X* NPs always seem to be compatible with individual-oriented predicates.

plains the fact that a single NP may take adverbial MPs with the same classifier but different quantities, as long as the MPs are associated with different predicates:

- (32) [3-ton sika nokotte-i-nai] 2-syurui-no kinzoku-o 2-ton
 [3-CL.ton other-than remain-Prog-Neg] 2-CL.species-Gen metal-Acc 2-CL.ton
 seiren-sita.
 purify-Past
 ‘(We) purified two tons of the two types of metal, of which only three tons remained.’

Our analysis entails that type-token dimensions of measurement (which can be picked out by classifiers) are ordered on a scale with respect to each other. An object that is already quantified at one level is cognitively *closed* to further quantification at a higher level on the scale.

- (33) a. Fish: *syurui* ‘species’ > *hiki* ‘individual-animal’
 b. Beer: *meigara* ‘brand’ > *syurui*¹² ‘species’ > *hon* ‘bottle’

We formalize this idea by letting a type classifier have as its CLTYPE value the set of further classifications (corresponding to the set of as-yet unspecified dimensions) open to a so-classified noun.

- (34) *syurui*:

$$\left[\text{CLTYPE } \left\{ \text{SPECIES, IND_ANIMAL} \right\} \right]$$

The syntactic rule for intranominal classifiers requires (i) that the intranominal classifier’s CLTYPE be a complete subset of the modified nominal’s; and (ii) the resulting nominal phrase have the intranominal classifier’s CLTYPE.

- (35) Prenominal MP Modification Rule¹³
- $$\begin{array}{c}
 \text{NP} \\
 \left[\begin{array}{l} \text{QSTORE } \boxed{5} \cup \{ \boxed{3} \} \\ \text{CLTYPE } \boxed{2} \end{array} \right] \\
 \swarrow \quad \searrow \\
 \text{MP} \qquad \text{N}' \\
 \left[\begin{array}{l} \text{RESTR } \boxed{3} \left[\begin{array}{l} \text{NUMBER } \boxed{6} \\ \text{CLTYPE } \boxed{2} \subseteq \boxed{1} \\ \text{INDEX } \boxed{4} \end{array} \right] \\ \text{CLTYPE } \boxed{2} \end{array} \right] \quad \left[\begin{array}{l} \text{CLTYPE } \boxed{1} \\ \text{INDEX } \boxed{4} \\ \text{QSTORE } \boxed{5} \end{array} \right]
 \end{array}$$

Example (36) and Figure 2 show the analysis of a grammatical sentence involving one intranominal and one adverbial MP.

¹²This leaves us with assuming polysemy for classifiers such as *syurui*, since different uses of *syurui* will require different members of their CLTYPE value corresponding to the possible token-level classification.

¹³The postnominal MP modification rule would be identical to (35), except for the directionality of phrasal combination, assuming that the noun remains the phrasal head. We ignore the issue of ensuring the correct location of case marking, as it plays no role in our analysis.

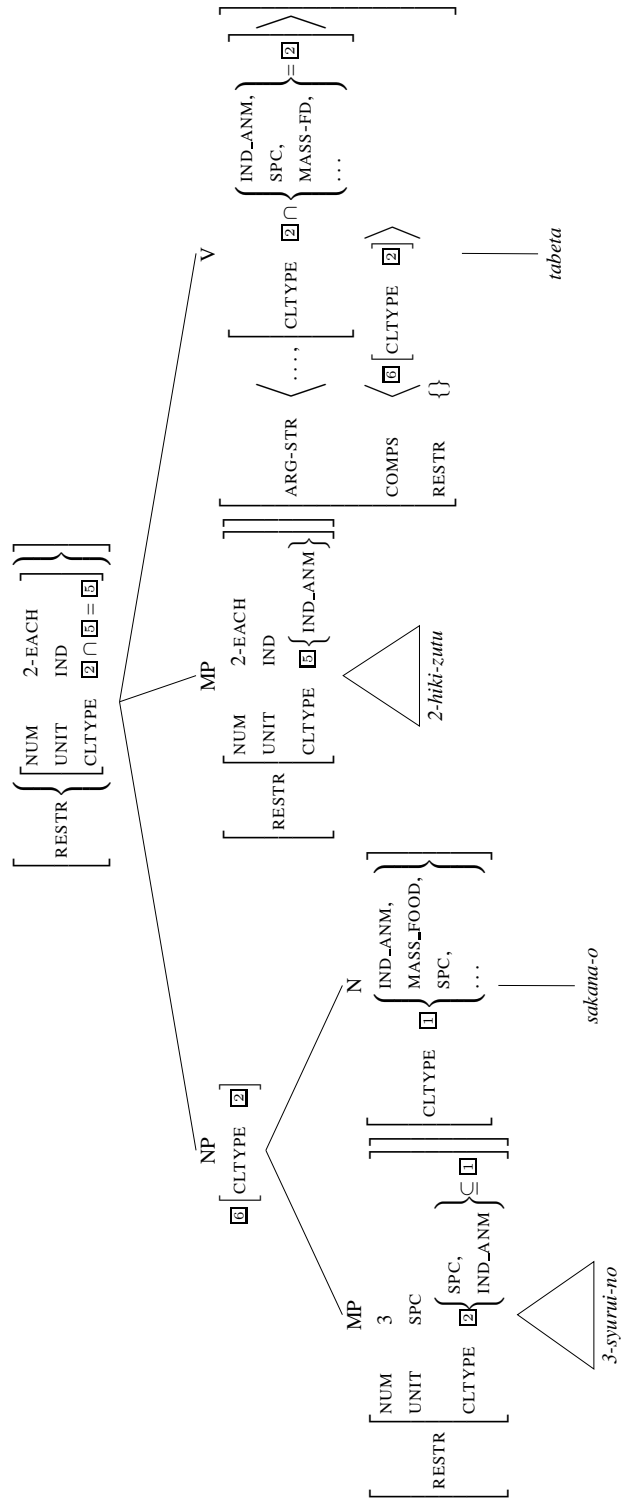

Figure 2: Analysis of Example (36)

- (36) 2-syurui-no sakana-o 3-biki-zutu tabe-ta.
 2-CL.species-Gen fish-Acc 3-CL.animal-each eat-Past
 ‘(I) ate three each of two types of fish.’

3.4 A problem neatly solved

The analysis presented in the previous section neatly solves the problem of why the interaction of prenominal classifiers with relativization depends on the word order of prenominal modifiers. We repeat the crucial data below.

- (31) a. 1,000-bu-no eigaka-s-are-ta hon-o moyasi-ta.
 1,000-CL.copy-Gen make.into.movie-Pass-Past book-Acc burn_{trans}-Past
 ‘(I) burned 1,000 copies of books that were made into movies.’
 b. ?*Eigaka-s-are-ta 1,000-bu-no hon-o moyasi-ta.
 make.into.movie-Pass-Past 1,000-CL.copy-Gen book-Acc burn_{trans}-Past
 c. Eigaka-s-are-ta 2-satu-no hon-o (gookei
 make.into.movie-Pass-Past 2-CL.bound-Gen book-Acc (in.total
 1,000-bu) moyasi-ta.
 1,000-CL.copy) burn_{trans}-Past
 ‘I burned (1,000 total copies of) two books that were made into movies.’

Example (31b) illustrates the generalization that a prenominal MP preceding an RC must be compatible with both the RC and matrix verbs. This generalization can be derived directly from our analysis in conjunction with the standard HPSG theory of relativization (Pollard and Sag, 1994), where relativized nominals are associated with their relative governing verbs by structure-sharing passed locally through the SLASH feature. If we assume that nominal modification is binary-branching, the sister of the RC will contain the MP if and only if the MP is between the RC and the noun. An example of the information-sharing for this word order is shown in (37). This particular structure is unacceptable within the relative clause as the RC verb *eigaka-s-are-ta* ‘made into a movie’ is incompatible with the ‘copy’ dimension corresponding to the classifier *bu*. If another RC verb, or the classifier *satu* ‘bound_object’, were substituted, this structure would be acceptable.

Alternatively, though, multiple prenominal modification could involve a single *flat* structure. In this case, there would be no intermediate node where just the prenominal classifier and the noun combine, and the relative clause would not have the prenominal MP’s restriction in it. This possibility is illustrated in (38). We propose that both these representations are possible and that native speakers may have internalized either or both of them. Speakers with the flat representation should have an acceptable reading of (31b); speakers with only the binary-branching representation should find it ungrammatical. Our analysis makes the clear prediction, however, that no speaker will accept (31b) *and* reject (31a).

(37)

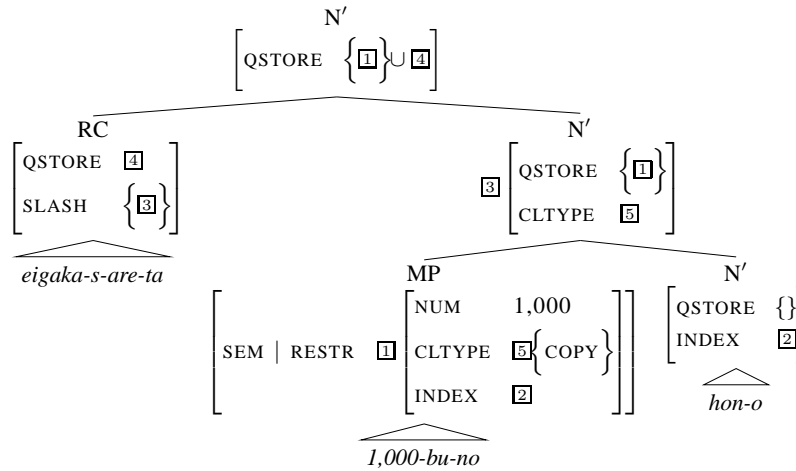

(38)

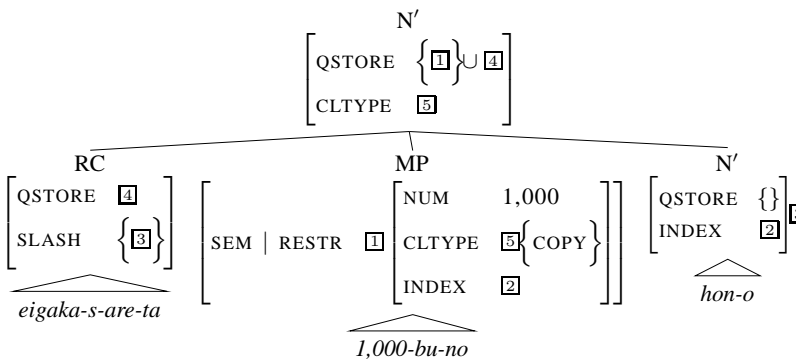

4 Other considerations

4.1 An alternative approach to cognitive objects and classifiers: Nunberg's "deferred ostension"

The problem of multiple measuring is a subtype of the more general problem of polysemy and vagueness: when are two distinct aspects of a phonological string's meaning part of a single sense, and how should cases of simultaneously using two aspects of a single meaning be represented? There has been long-standing interest within generative grammar in a precise answer to this problem. An early proposal in transformational literature was to represent these cases by a single supertype representation in the lexicon with multiple subtypes, such as the abstract and concrete aspects of a *book*. The more recent theory of Pustejovsky (1995) is much more elaborate but like in spirit. An alternative set forth by Nunberg (1979) argued against an explicit *lexical* treatment of polysemy, and instead dealt with reference to multiple aspects of an apparently single linguistic entity uniformly via pragmatic means ("deferred ostension"):

(39) a. The chair you're sitting in was faddish during the 1960's. (token,type)

- b. The window was broken, so he went right through it. (cover, opening)
- c. Yeats allegedly didn't enjoy hearing himself read. (person, oeuvre)
- d. The newspaper decided to change its format. (publishing company, publication)

Nunberg argued that the multiple possibilities of reference in examples such as (39) should be handled by *relations* between referent types: between token and type, a publisher and a publication, and so forth:

(40) $r(\textit{token}, \textit{type}), r(\textit{publisher}, \textit{publication}), r(\textit{author}, \textit{oeuvre}), r(\textit{cover}, \textit{opening})$

Although Nunberg doesn't explicitly mention it, the verb has to play a filtering function in such an account, ruling out unsuitable referent types (e.g. ruling out the 'person' reading for 'himself' in (39c)). Our approach, although it treats multiply-classified nouns as single, complex cognitive objects, yields equivalent results in terms of empirical predictions. It is not clear, however, how the type-token asymmetry for intranominal + adverbial classifier combinations might be dealt with in an account such as Nunberg's, where types and tokens can be mapped back and forth between.

4.2 Classifier ordering reversals

There are also some exceptions to the general ordering principles for type-token and alternative-unit classifiers (cf. (14a) and (15b)). These generally seem explainable on semantic grounds; Example (41) below illustrates instances of reversal.

- (41) a. 2-hiki-no sakana-o 3-syurui tabe-te-mi-ta.
 two-CL.ind.animal-Gen fish-Acc 3-CL.species eat-Ger-look-Past
 '(I) tried three different types of two-fish dishes [i.e., dishes consisting of two individual fish].'
- b. 100-satu-no hon-o 3-hako hakon-da.
 100-CL.bound-Gen book-Acc 3-CL.box transport-Past
 '(We) moved three boxes of 100 books [each box containing 100 books].'

In all these examples, the adverbial MP measures in units determined by the combination $[\text{MP}_{\text{prenom}} \text{N}]$, resulting in a multiplicative interaction between the classifiers. Example (41a), for example, involves six fish in total. In the ordinary multiple-classifier instances, in contrast, multiplicative interaction is not forced (although it can often be specified with the use of *zutu* 'each'). We propose that these are cases of $\text{MP}_{\text{prenom}} + \text{N}$ combinations being used here as an irreducible cognitive object, distinct from the base N.

5 Conclusions

In this paper we have investigated a number of issues in the syntax and semantics of Japanese noun-classifier matching, showing that it involves non-transitive

relationships similar to those encountered in case government and case concord in European languages. We have shown that similar formal techniques are required for the two problems. We have further shown that there are a variety of syntactic relationships between classifier and noun and that syntax strongly determines the semantic import of measure phrases. We have shown how asymmetries in positional possibilities for classifiers in type-token relationships follow directly from semantic principles, and provided a formal analysis which directly derives correct generalizations about the interaction between word order and felicity for prenominal classifiers and relative clauses, as well as generalizations about asymmetries between dimensions of measurement that can and cannot be excluded by governing verbs. The formal analysis generalizes cleanly to technically difficult cases of noun phrase coordination.

In addition to further illuminating the syntax and semantics of an important area of Japanese grammar, the results of this paper have greater implications in two respects. First, we have shown that the most complicated problems of non-transitive information sharing, first discussed by Ingria (1990) for the purely formal problem European case concord, also occur in a different language family for a phenomenon that rests squarely on the syntax-semantics boundary. Second, this paper sheds light on subtle problems of reference and polysemy taken up by authors such as Nunberg (1979) and Pustejovsky (1995). Although much of what we discuss here is compatible with Nunberg's accounts, the syntax of Japanese has allowed us to clearly show that different aspects of complex cognitive objects (deferred referents in Nunberg's theory) are in some cases hierarchically related, a finding not at all obvious from prior studies focused on English.

Acknowledgements

A preliminary version of this work was also presented at the 2003 Stanford Semantics Workshop, where we received valuable feedback. We are particularly grateful to Francis Bond, Hana Filip, Tsuneko Nakazawa, Ivan Sag, and three anonymous reviewers for valuable discussion and suggestions.

References

- Aikhenvald, A. (2000). *Classifiers: a Typology of Noun Categorization Devices*. CUP.
- Bayer, S. (1996). The coordination of unlike categories. *Language*, 72(3):579–616.
- Bayer, S. and Johnson, M. (1995). Features and agreement. In *Proceedings of the 1995 ACL*, pages 70–76. Association of Computational Linguistics.
- Blevins, J. P. (2003). Feature-based grammar. In Borsley, R. D. and Börjars, K., editors, *Nontransformational Syntax*. Blackwell. To appear.
- Carlson, G. (1977). A unified analysis of the English bare plural. *Linguistics and Philosophy*, 1(3):413–458.
- Dalrymple, M. and Kaplan, R. (2000). Feature indeterminacy and feature resolution in description-based syntax. *Language*, 77(4).
- Daniels, M. (2001). On a type-based analysis of feature indeterminacy and the coordination of unlikes. In *Proceedings of HPSG 2001*. CSLI.

- Denny, J. P. (1979). Semantic analysis of selected Japanese classifiers for units. *Linguistics*, 89:73–111.
- Downing, P. (1996). *Numeral Classifier Systems: The Case of Japanese*. John Benjamins.
- Gunji, T. and Hasida, K. (1998). Measurement and quantification. In Gunji, T. and Hasida, K., editors, *Topics in Constrained Grammar of Japanese*, pages 39–79. Kluwer.
- Iida, A. (2000). *Nihongo syuyô zuyosûsi no imi to yôhō*. PhD thesis, University of Tokyo.
- Ingria, R. J. P. (1990). The limits of unification. In *Proceedings of the 28th Annual Meeting of the ACL*, pages 194–204. Association for Computational Linguistics.
- Kathol, A. (1999). Agreement and the syntax-morphology interface in HPSG. In Levine, R. and Green, G., editors, *Studies in Current Phrase Structure Grammar*, pages 223–274. CUP.
- Levy, R. (2001). Feature indeterminacy and the coordination of unlikes in a totally well-typed HPSG. March 19, 2001.
- Levy, R. and Pollard, C. (2001). Coordination and neutralization in HPSG. In *Proceedings of HPSG 2001*. CSLI.
- Matsumoto, Y. (1993). Japanese numeral classifiers: a study of semantic categories and lexical organization. *Linguistics*, 31:667–713.
- Nunberg, G. (1979). The non-uniqueness of semantic solutions: Polysemy. *Linguistics and Philosophy*, 3:143–184.
- Paik, K. and Bond, F. (2002). Spatial representation and shape classifiers. In Beaver, D., Casillas Martínez, L., and Clark, B., editors, *The Construction of Meaning*, pages 163–180. CSLI.
- Pollard, C. and Sag, I. A. (1994). *Head-Driven Phrase Structure Grammar*. Stanford: CSLI; Chicago: The University of Chicago Press.
- Pullum, G. K. and Zwicky, A. M. (1986). Phonological resolution of syntactic feature conflict. *Language*, 62(4):751–773.
- Pustejovsky, J. (1995). *The Generative Lexicon*. MIT Press.
- Sag, I. (2002). Coordination and underspecification. In *Proceedings of HPSG 2002*.
- Zaenen, A. and Karttunen, L. (1984). Morphological non-distinctiveness and coordination. In *Proceedings of ESCOL '84*, pages 309–320.

Object-to-subject-raising and lexical rule: An analysis of the German passive

Stefan Müller 

University of Bremen

Proceedings of the 10th International Conference on
Head-Driven Phrase Structure Grammar

Michigan State University

Stefan Müller (Editor)

2003

Stanford, CA: CSLI Publications

pages 278–297

Keywords: passive, case, lexical rule, HPSG

Müller, Stefan. 2003. Object-to-subject-raising and lexical rule: An analysis of the German passive. In Stefan Müller (ed.), *Proceedings of the 10th International Conference on Head-Driven Phrase Structure Grammar, Michigan State University*, 278–297. Stanford, CA: CSLI Publications. DOI: 10.21248/hpsg.2003.16.



Abstract

It is a much-debated issue whether one should assume separate lexical entries for participles used in passive and perfect constructions or whether there is just one lexical entry that is used in different ways depending on whether a passive or perfect auxiliary is present in the clause.

In previous work I criticized approaches trying to analyze the passive with one lexical entry for making empirically wrong predictions and suggested a lexical rule-based approach where two different lexical items for the participle are licensed.

In this paper I show how Heinz and Matiasek's (1994) formalizations of Haider's (1986) ideas can be extended and modified in a way that both modal infinitives and control constructions can be captured correctly. The suggested analysis needs only one lexical item for participles, base form infinitives, and *zu* infinitives irrespective of their usage in active or passive-like structures.

1 Introduction

Over the years there have been many suggestions in the HPSG literature for treating the German passive. Kiss (1992, S. 276), Hinrichs and Nakazawa (1998), Kathol (1998, S. 255), and Müller (2001) suggested lexical rule-based approaches, while (Kathol, 1991, 1994; Heinz and Matiasek, 1994; Lebeth, 1994; Pollard, 1994; Ryu, 1997; Müller, 1999) followed ideas by Haider (1986) and developed Object-To-Subject-Raising analyses.

The advantage of such raising analyses is that a single entry for the second participle is sufficient for both perfect tense and passive constructions. The auxiliary for the perfect (1a), passive (1b), or dative passive (1c) attracts the arguments of the embedded participle *geschenkt* ('given') in a way that is appropriate for the construction at hand.

- (1) a. Der Mann hat den Ball dem Jungen geschenkt.
the man_{nom} has the ball_{acc} the boy_{dat} given
'The man gave the ball to the boy.'
- b. Der Ball wurde dem Jungen geschenkt.
the ball_{nom} was the boy_{dat} given
'The ball was given to the boy.'
- c. Der Junge bekam den Ball geschenkt.
the boy_{nom} got the ball_{acc} given
'The boy got the ball as a present.'

[†]I want to thank Detmar Meurers, two anonymous reviewers of NLLT, and two anonymous reviewers of CSLI Publications for comments regarding passive.

The analysis is similar to the one in (Müller, 2002, Chapter 3). In comparison to (Müller, 2002, Chapter 3), I extended the discussion in Section 3.2 and added an analysis of agent phrases as adjuncts (Section 5). The XCOMP feature has been eliminated, since it is not necessary. On XCOMP see (Müller, To Appear b).

In the passive in (1b), the accusative object becomes the subject and the logical subject of the main verb is suppressed. In the dative passive, a dative object is promoted to subject.

The modal infinitive constructions in (2) show an alternation between active and passive argument realization that is similar to the alternations in (1a–b): In (2a) all arguments of the infinitive are realized and the sentence corresponds to an active sentence. In (2b), however, the subject of the active sentence is suppressed, as it is the case in passive sentences.

- (2) a. Ihr habt die Angelegenheit zu erledigen.
 you_{nom} have the matter_{acc} to settle
 ‘You have to settle the matter.’
- b. Die Angelegenheit ist von euch zu erledigen.
 the matter_{nom} is by you to settle
 ‘The matter is to be settled by you.’

In (Müller, 2001) I pointed out that Heinz and Matiasek’s approach to the passiv, the representation of valence, and to control is not compatible with this data. While Haider’s proposal covers the data in (2), Heinz and Matiasek’s proposal for (1) did not extend to (2). If one accounts for the diverse patterns of argument realizations in (1) with one lexical item for the participle, it seems to be desirable to account for the sentences in (2) with a single representation for the *zu* infinitive.

Since I believed that Heinz and Matiasek’s approach could not be extended to deal with the data in (2), I formulated a lexical rule-based analysis that stipulates two distinct lexical entries per participle. A similar duplication of lexical entries has to be assumed for *zu* infinitives.

In this paper, I show that Heinz and Matiasek’s approach can be adapted to Haider’s proposals so that it also covers the modal infinitive constructions. The paper will be structured as follows: I will first discuss Haider’s approach and Heinz and Matiasek’s formalization of Haider’s analysis, I then discuss the approaches by Kathol and Pollard, repeat some of my 2001 criticism, point out further problems, and then show how Heinz and Matiasek’s approach can be modified to cover the modal infinitives.

2 Haider’s Analysis

Haider suggests designating the argument of the verb that has subject properties. He refers to this argument as the designated argument (DA). He marks the designated argument in lexical entries by underlining the corresponding θ -role in the lexical entry of the verb. For intransitive verbs this looks as follows:

- (3) a. $V(\underline{\theta})$ (tanzen = ‘to dance’, unergative)
 b. $V(\theta)$ (ankommen = ‘to arrive’, unaccusative)

For transitive verbs one gets the following representation:

- (4) a. $V(\underline{\theta}, \theta)$ vs. $V(\underline{\theta})$ (etwas essen ‘eat something’ vs. essen ‘eat’)
 b. $V(\underline{\theta}, \theta)$ vs. $V(\theta)$ (etwas essen ‘eat something’ vs. gegessen werden ‘be eaten’)

Haider assumes the following rules:

- (5) a. the second participle blocks the DA
 b. *zu* blocks the external argument
 c. *haben* deblocks blocked arguments
 d. *sein* realizes non-blocked arguments

Contrary to my 2001 claims, both passive variants and modal infinitives can be explained with these simple rules. In the following sections I will discuss proposals for the analysis of the German passive that build on Haider’s ideas.

3 Proposals for the Formalization of Haider’s Ideas

3.1 Heinz and Matiasek

Heinz and Matiasek introduce a new list-valued feature DA. If a verb has a designated argument, i.e., if it is unergative, the DA list contains one element which is identical with an element in the SUBCAT list of the verb. The DA list is the empty list, if there is no designated argument, i.e., if the verb is unaccusative. (6) shows the representations for the prototypical verbs *ankommen* (‘to arrive’), *tanzen* (‘to dance’), *auffallen* (‘to attract somebody’s attention’), *lieben* (‘to love’), *schenken* (‘to give as a present’), *helfen* (‘to help’):

- | (6) | DA | SUBCAT |
|------------------------------|---|--|
| a. <i>ankommen</i> (unacc): | $\langle \rangle$ | $\langle \text{NP}[\textit{str}] \rangle$ |
| b. <i>tanzen</i> (unerg): | $\langle \boxed{\square} \text{NP}[\textit{str}] \rangle$ | $\langle \boxed{\square} \rangle$ |
| c. <i>auffallen</i> (unacc): | $\langle \rangle$ | $\langle \text{NP}[\textit{str}], \text{NP}[\textit{ldat}] \rangle$ |
| d. <i>lieben</i> (unerg): | $\langle \boxed{\square} \text{NP}[\textit{str}] \rangle$ | $\langle \boxed{\square}, \text{NP}[\textit{str}] \rangle$ |
| e. <i>schenken</i> (unerg): | $\langle \boxed{\square} \text{NP}[\textit{str}] \rangle$ | $\langle \boxed{\square}, \text{NP}[\textit{str}], \text{NP}[\textit{ldat}] \rangle$ |
| f. <i>helfen</i> (unerg): | $\langle \boxed{\square} \text{NP}[\textit{str}] \rangle$ | $\langle \boxed{\square}, \text{NP}[\textit{ldat}] \rangle$ |

ankommen and *auffallen* are unaccusative verbs while the other verbs are unergative.

str is the abbreviation for structural case. *ldat* stands for lexical dative. I assume – simplifying a bit – that the first element in the SUBCAT list that has structural case gets nominative and all other elements in the SUBCAT list get accusative (for a formalization of case assignment see (Meurers, 1999)).

Heinz and Matiasek suggest the lexical rule in (7) which relates the lexical item of the second participle to the lexical item of the infinitive.

$$(7) \left[\begin{array}{l} \text{HEAD} \left[\begin{array}{l} \text{VFORM } bse \\ verb \end{array} \right] \\ \text{DA } \boxed{1} \\ \text{SUBCAT } \boxed{1} \oplus \boxed{2} \end{array} \right] \mapsto \left[\begin{array}{l} \text{HEAD} \left[\begin{array}{l} \text{VFORM } ppp \\ verb \end{array} \right] \\ \text{DA } \boxed{1} \\ \text{SUBCAT } \boxed{2} \end{array} \right]$$

This lexical rule removes the designated argument from the SUBCAT list. Therefore this element cannot be realized in projections of the participle. (8) shows the result of the application of the rule to the verbs in (6):

(8)	DA	SUBCAT
a. angekommen (unacc):	$\langle \rangle$	$\langle \text{NP}[str] \rangle$
b. getanzt (unerg):	$\langle \text{NP}[str] \rangle$	$\langle \rangle$
c. aufgefallen (unacc):	$\langle \rangle$	$\langle \text{NP}[str], \text{NP}[ldat] \rangle$
d. geliebt (unerg):	$\langle \text{NP}[str] \rangle$	$\langle \text{NP}[str] \rangle$
e. geschenkt (unerg):	$\langle \text{NP}[str] \rangle$	$\langle \text{NP}[str], \text{NP}[ldat] \rangle$
f. geholfen (unerg):	$\langle \text{NP}[str] \rangle$	$\langle \text{NP}[ldat] \rangle$

Heinz and Matiasek suggest the following lexical entry for the passive auxiliary:

$$(9) \textit{werden} \text{ (Passive Auxiliary):} \\ \left[\begin{array}{l} \text{DA } \langle \rangle \\ \text{SUBCAT } \boxed{1} \oplus \langle \text{V}[ppp, \text{DA } \langle [] \rangle, \text{SUBCAT } \boxed{1}] \rangle \end{array} \right]$$

The passive auxiliary selects a participle which has a designated argument, i.e., an element in the DA list. This correctly predicts that the passive with unaccusative verbs is excluded, since unaccusative verbs have an empty DA list. Because of the coindexing of the SUBCAT value of *werden* ($\boxed{1}$) with the SUBCAT value of the embedded participle it is ensured that all non-blocked arguments of the participle are raised to the matrix predicate and can be realized as arguments of the matrix predicate at the surface.

In contrast to the passive auxiliary, the perfect auxiliary deblocks the designated argument. The SUBCAT value of the auxiliary is the concatenation of the DA value and of the SUBCAT value of the embedded participle:

$$(10) \textit{haben} \text{ (Perfect Auxiliary):} \\ \left[\begin{array}{l} \text{DA } \boxed{1} \\ \text{SUBCAT } \boxed{1} \oplus \boxed{2} \oplus \langle \text{V}[ppp, \text{DA } \boxed{1}, \text{SUBCAT } \boxed{2}] \rangle \end{array} \right]$$

Heinz and Matiasek do not discuss modal infinitives, but they discuss control constructions and other raising constructions that involve *zu* infinitives. They assume that the subject of *zu* infinitives and the subject of infinitives without *zu* is represented in the SUBCAT list of the verb. This kind of representation was used in (Pollard and Sag, 1987) and (Pollard and Sag, 1994, Kapitel 1–8). Pollard and Sag (1994, Kapitel 9) followed Borseley’s suggestions (1987) and represented the subject in a separate list—the SUBJ list. Borsley (1989) discusses Welsh data and suggests representing the subject of finite verbs like other arguments on the SUBCAT list. Only subjects of non-finite verbs are represented under SUBJ. Pollard (1996) and other authors adapted this proposal for German grammars.

Such a modification of the representation of subjects of non-finite verbs in general has the advantage that the blocking and unblocking mechanisms which have been discussed in connection with the passive can be used for modal infinitives as well. How Heinz and Matiasek’s analysis can be extended and modified so that it also covers modal infinitives will be discussed in section 4. Before doing so, I want to discuss the analyses that were suggested by Kathol, Pollard, and Ryu.

3.2 Kathol

Kathol (1994, Chapter 7.3.3) suggests the representations in (11) for participles and the lexical entries in (12) for the auxiliaries:

- (11)
- | | EXT | SUBJ | COMPS |
|------------------------|--|---|-------------------|
| a. angekommen (unacc): | $\langle \boxed{1} \text{ NP}[\textit{nom}] \rangle$ | $\langle \boxed{1} \rangle$ | $\langle \rangle$ |
| b. geschlafen (unerg): | $\langle \text{NP}[\textit{nom}] \rangle$ | $\langle \rangle$ | $\langle \rangle$ |
| c. geliebt (unerg): | $\langle \text{NP}[\textit{nom}] \rangle$ | $\langle \text{NP}[\textit{acc}] \rangle$ | $\langle \rangle$ |
- (12)
- a. *haben* (Perfect Auxiliary)

$$\left[\begin{array}{l} \text{SUBJ } \boxed{3} \\ \text{COMPS } \boxed{2} \oplus \boxed{1} \oplus \langle \text{V}[\text{SUBJ } \boxed{2}, \text{EXT } \boxed{3}, \text{COMPS } \boxed{1}] \rangle \end{array} \right]$$

$$\wedge \boxed{2} \neq \boxed{3}$$
 - b. *sein* (Perfect Auxiliary)

$$\left[\begin{array}{l} \text{SUBJ } \boxed{2} \\ \text{COMPS } \boxed{1} \oplus \langle \text{V}[\text{SUBJ } \boxed{2}, \text{EXT } \boxed{2}, \text{COMPS } \boxed{1}] \rangle \end{array} \right]$$
 - c. *werden* (Passive Auxiliary)

$$\left[\begin{array}{l} \text{COMPS } \boxed{1} \oplus \langle \text{V}[\text{SUBJ } \langle \text{NP}[\textit{acc}] \boxed{2} \rangle, \text{COMPS } \boxed{1}] \rangle \\ \text{SUBJ } \langle \text{NP}[\textit{nom}] \boxed{2} \rangle \end{array} \right]$$

Kathol follows Pollard (1996) in assuming that SUBJ is not a valence feature (p. 243), i.e., both the elements in EXT and those in SUBJ are blocked. The perfect auxiliary

haben in (12a) deblocks the elements in EXT and SUBJ. In perfect constructions with unaccusative verbs, the auxiliary *sein* in (12b) is used and only the element that is represented under EXT can be realized if the auxiliary verb is finite.

Kathol's proposal has the advantage that the nominative argument of all participles is represented uniformly under EXT. However, his representation is not without problems, since forms like *geliebt* do not have any element in the SUBCAT list at all. This predicts that the participle cannot be combined with complements. Since in Kathol's analysis, both the SUBJ element and the EXT element are deblocked by the finite auxiliary, the phrase *seine Frau* has to be analyzed as an argument of the auxiliary in (13). Therefore it is unclear why the NP can appear together with the participle in the position before the finite verb, a position which is usually occupied by a single constituent.¹

- (13) Seine Frau geliebt hat er nie.
 his wife loved has he never
 'He never loved his wife.'

Furthermore, it remains unclear how subjectless verbs can be represented in a way that is compatible with the entry for *haben*. For the subjectless verb *grauen* ('to dread'), one would assume a representation like (14b):

- (14) a. Dem Student hat vor der Prüfung gegraut.
 the student_{dat} has before the exam dreaded
 'The student dreaded the exam.'
- b. gegraut (unerg):
 EXT ⟨ ⟩ SUBJ ⟨ ⟩ SUBCAT ⟨ NP[*dat*], PP[*vor*] ⟩

With such a lexical entry the embedding under *haben* is ruled out, since the value of EXT and SUBJ are identical. The only solution to this problem would be the stipulation of an empty subject for subjectless verbs. One would need further constraints to rule out such empty subjects at positions where overt referential or expletive subjects are required.

Apart from this problem, this approach cannot account for modal infinitives and incoherent infinitival constructions with one lexical entry: Since the accusative object is represented as an element of the SUBJ list, no VP can be formed. The only solution to this problem is to stipulate a separate lexical entry for *zu*-infinitives that can form a VP. As was discussed in the introduction of this paper, the avoidance of the stipulation of two separate entries for non-finite verbs is the goal of object-to-subject-raising analyses.

3.3 Kathol and Pollard

Pollard (1994) elaborates Kathol's suggestions (1991) and designates the element that has accusative properties instead of designating the element with subject properties as was suggested by Haider (See also (Müller, 1999, Chapter 15.3) for an

¹For examples that seem to violate the V2 property of German see (Müller, To Appear a).

extension of Pollard's proposal.). For our example verbs, these authors assume the following representations:

- (15)
- | | SUBJ | ERG | SUBCAT |
|---------------------------|--|-----------------------------|--|
| a. ankommen (unacc): | $\langle \boxed{1} \text{ NP}[\textit{str}] \rangle$ | $\langle \boxed{1} \rangle$ | $\langle \rangle$ |
| b. tanzen (unerg): | $\langle \text{NP}[\textit{str}] \rangle$ | $\langle \rangle$ | $\langle \rangle$ |
| c. auffallen (unacc): | $\langle \boxed{1} \text{ NP}[\textit{str}] \rangle$ | $\langle \boxed{1} \rangle$ | $\langle \text{NP}[\textit{ldat}] \rangle$ |
| d. lieben (unerg): | $\langle \text{NP}[\textit{str}] \rangle$ | $\langle \boxed{1} \rangle$ | $\langle \boxed{1} \text{ NP}[\textit{str}] \rangle$ |
| e. schenken (unergative): | $\langle \text{NP}[\textit{str}] \rangle$ | $\langle \boxed{1} \rangle$ | $\langle \boxed{1} \text{ NP}[\textit{str}], \text{NP}[\textit{ldat}] \rangle$ |
| f. helfen (unerg): | $\langle \text{NP}[\textit{str}] \rangle$ | $\langle \rangle$ | $\langle \text{NP}[\textit{ldat}] \rangle$ |

For unaccusative verbs like *ankommen* ('to arrive') and *auffallen* ('to notice'), the element in ERG is identical with the element in SUBJ. For unergative verbs, the element in ERG is identical to the direct object if there is one (*lieben* ('to love')), or the ERG value is the empty list if there is no accusative object, as for instance in the case of *tanzen* ('to dance') and *helfen* ('to help').

At the heart of the passivization analysis of Pollard is the object-to-subject raising lexical entry for the passive auxiliary in (16).

- (16) *werden* (Passive Auxiliary following (Pollard, 1994)):

$$\left[\begin{array}{l} \text{HEAD} \left[\begin{array}{l} \text{SUBJ } \boxed{1} \\ \text{ERG } \boxed{1} \\ \textit{verb} \end{array} \right] \\ \text{SUBCAT } \boxed{2} \oplus \langle \text{V}[\textit{ppp}], \text{SUBJ } \langle \text{NP}[\textit{str}]_{\textit{ref}} \rangle, \text{ERG } \boxed{1}, \text{SUBCAT } \boxed{1} \oplus \boxed{2} \rangle \end{array} \right]$$

The passive auxiliary embeds a verb with the VFORM *ppp*, i. e. a participle. The auxiliary subtracts the value of ERG ($\boxed{1}$) from the SUBCAT list of the embedded verb. The rest of the arguments ($\boxed{2}$) is raised.

This lexical entry only allows the combination with verbs that have an ERG value which is a prefix of the SUBCAT list of the embedded verb. This is the case for verbs that have the empty list as ERG value (*tanzen*, *helfen*). For such verbs, $\boxed{1}$ is the empty list. The SUBJ value of the verbal complex that results when participle and auxiliary are combined is the empty list as well. The result is a subjectless construction, the so-called impersonal passive. If we embed a transitive verb like *lieben* under *werden*, an ERG list that contains one element is subtracted from the valence list of the embedded participle. In the case of *lieben*, the remaining list ($\boxed{2}$) is the empty list. Since the SUBJ list of the resulting verbal complex is identical to the ERG value of the embedded participle, we get for *geliebt wird* a verbal complex that has the accusative object of *lieben* as subject. This kind of construction is the so-called personal passive.

I showed in (Müller, 1999, p. 374) that passive sentences like (17) in which the subject is fronted together with the participle are problematic for this approach.

- (17) a. Zwei Männer erschossen wurden während des Wochenendes.
 two men_{nom} shot were_{pt} during the weekend
 ‘Two men were shot during the weekend.’
- b. Ein verkanntes Meisterwerk dem Musiktheater zurückgewonnen
 a misjudged masterpiece_{nom} the music.theater_{dat} back.won
 ist da nicht.
 is there not
 ‘The music theater has not exactly recovered a neglected masterpiece there.’

The object of *erschließen* in (17a) can be combined with the participle to form the phrase *zwei Männer erschossen*, but then it is not contained in the SUBCAT list any longer. The passive auxiliary *wurden* requires that the ERG value of the embedded participle is a prefix of its SUBCAT list which is not the case for the projection *zwei Männer erschossen*. Therefore the fronted projection cannot be analyzed as a filler of an unbounded dependency construction that fills the gap for a complement of *wurden* and hence the sentences in (17) are unanalyzable.

Before I turn to the analysis, I want to discuss Ryu’s proposal in the next subsection.

3.4 Ryu

Ryu (1997) suggests two new features for distinguishing the external (EXTARG) and the internal argument (INTARG). These features are represented as parts of the argument structure of a verb. The argument structure is described by a feature description that consists of a list of referential indices and the two features pointing to the external and the internal argument if there are any. (18) shows an example for the transitive verb *schlagen* (‘to beat’).

- (18) Argument Structure of *schlagen* (‘to beat’) according to (Ryu, 1997, p. 376):
- $$\left[\begin{array}{l} \text{EXTARG} \langle \boxed{1} \rangle \\ \text{INTARG} \langle \boxed{2} \rangle \\ \text{ARGS} \langle \boxed{1} \rangle \oplus \langle \boxed{1} \rangle \end{array} \right]$$

He suggests the following lexical entries for the passive auxiliary *werden* (p. 377, p. 379):

(19) *werden* (Auxiliary for the Personal Passive, fi nite form):

SUBJ	⟨ NP[<i>nom</i>] _[2] ⟩			
COMPS	⟨ PP[<i>von</i>] _[1] ⟩ ⊕ 4 ⊕	HEAD	[VF _{FORM} <i>psp</i> <i>verb</i>
		COMPS	[NP[<i>acc</i>] _[2] ⟩ ⊕ 4
		ARGSTR	[EXTARG ⟨ 1 ⟩ INTARG ⟨ 2 ⟩ ARGS ⟨ 1 ⟩ ⊕ ⟨ 2 ⟩ ⊕ 3
]]
				⟩

(20) *werden* (Auxiliary for the Impersonal Passive, fi nite form):

SUBJ	⟨ ⟩			
COMPS	⟨ PP[<i>von</i>] _[1] ⟩ ⊕ 4 ⊕	HEAD	[VF _{FORM} <i>psp</i> <i>verb</i>
		COMPS	[4
		ARGSTR	[EXTARG ⟨ 1 ⟩ INTARG ⟨ ⟩ ARGS ⟨ 1 ⟩ ⊕ 3
]]
				⟩

Examples like (17a) and (21) are problematic for Ryu's account since he assumes the argument structure to be represented at lexical items only.²

(21) Einem Jungen geschenkt wurde das Buch dann doch nicht.
 a boy_{dat} given was the book_{nom} then after.all not
 'After all, the book was not given to a boy.'

In (17a) and (21), the position before the fi nite verb is occupied by a complex constituent. This complex constituent is a filler of a nonlocal dependency. *wurde* is combined with a trace and the selectional requirements of the passive auxiliary are identified with the properties of that trace. Since the argument structure is not projected, the constituent *einem Jungen geschenkt* is either incompatible with the trace or the grammar overgenerates: If the value of ARGSTR of phrases is *none* or something similar, the analysis fails since the restrictions on the trace are incompatible with the filler. If the value of ARGSTR of phrases is not constrained, the grammar wrongly admits sentences like (22) in which the participle of an unaccusative verb is fronted together with an argument.

²For a discussion of problems that arise if one projects the argument structure see (Müller, 2002, p. 201).

- (22) * Dem Mann aufgefallen wurde nicht.
 the man noticed was not
 Intended: ‘The man did not notice somebody.’

(22) can be analyzed as an impersonal passive since the requirement that the embedded participle has to have an element in EXTARG cannot be enforced since this information is not present at the projection *dem Mann aufgefallen*.

Turning to another problem, the following sentence causes problems for auxiliary-based analyses that treat the agent PP as argument, since the PP had to be an (optional) argument of the auxiliary.³

- (23) Von Grammatikern angeführt werden auch Fälle mit dem Partizip
 by grammarians mentioned get also cases with the participle
 intransitiver Verben ...⁴
 intransitive verbs
 ‘Grammarians also mention cases with the participle of intransitive verbs.’

As was mentioned already, fronting in German is generally understood as involving only a single constituent. The example in (23) shows that partial VPs can include the agent PP. Since Ruy assumes that the PP is a dependent of the auxiliary, he cannot explain why it appears together with the participle *angeführt* (‘mentioned’) before the finite verb.

Having discussed previous proposals and their shortcomings, I now present a new proposal that extends and modifies Heinz and Matiassek’s proposal and solves the mentioned puzzles.

4 The Analysis

As mentioned in Section 3.1, I assume that the subject of *zu* infinitives is represented in the SUBJ list as was suggested by Borsley (1989) and Pollard (1996). If we want to have syntactically identical lexical entries for the perfect auxiliary *haben* and for the *haben* that forms modal infinitive constructions and if we use different features for representing the blocked subject of *zu* infinitives (SUBJ) and of the underlying subject (DA), the auxiliary has to deblock both the SUBJ and DA elements. The lexical entry for *haben* would look like (24):

- (24) *hab-* (Perfect Auxiliary and Modal Infinitive, Preliminary):

$$\left[\text{SUBCAT } \boxed{1} \oplus \boxed{2} \oplus \boxed{3} \oplus \left\langle \text{V}[\text{ppp}, \text{SUBJ } \boxed{1}, \text{DA } \boxed{2}, \text{SUBCAT } \boxed{3}] \right\rangle \right]$$

The problem with this approach is that unergative verbs like *tanzen* (‘to dance’) have a surface subject that is simultaneously the designated argument. Therefore both the SUBJ list and the DA list would contain an element. If we deblock both

³See (Müller, 1999, p. 376) and (Müller, 2001, p. 250).

⁴In the main text of (Askedal, 1984, p. 28).

elements simultaneously we get a list that contains the subject of the unergative verb twice. This problem could be solved technically by stipulating that the DA value of *zu* infinitives is always the empty list. Instead of this ad hoc solution I suggest that blocked elements are always presented in the same list. Participles and infinitival forms are derived from stem entries by lexical rules. For participles the element that is identified as the designated argument in the stem entry is removed from the SUBCAT list and represented as element of SUBJ. For infinitives the first element in the SUBCAT list of the stem that has structural case is represented in the SUBJ list. The respective lexical rules are given in (25) and (27): (25) is the rule that blocks the designated argument and (27) blocks the syntactic subject:

$$(25) \left[\begin{array}{l} \text{SYNSEM|LOC|CAT} \\ \text{HEAD} \\ \text{SUBCAT } \boxed{1} \oplus \boxed{2} \end{array} \begin{array}{l} \left[\begin{array}{l} \text{DA } \boxed{1} \\ \text{verb} \end{array} \right] \end{array} \right] \mapsto \left[\begin{array}{l} \text{SYNSEM|LOC|CAT} \\ \text{HEAD} \\ \text{SUBCAT } \boxed{2} \end{array} \begin{array}{l} \left[\begin{array}{l} \text{VFORM } \textit{ppp} \\ \text{SUBJ } \boxed{1} \\ \text{verb} \end{array} \right] \end{array} \right]$$

The lexical rule (25) licenses lexical items with the values in (26):

(26)	SUBJ	SUBCAT
a. angekommen (unacc):	⟨ ⟩	⟨ NP[<i>str</i>] ⟩
b. getanzt (unerg):	⟨ NP[<i>str</i>] ⟩	⟨ ⟩
c. aufgefallen (unacc):	⟨ ⟩	⟨ NP[<i>str</i>], NP[<i>ldat</i>] ⟩
d. geliebt (unerg):	⟨ NP[<i>str</i>] ⟩	⟨ NP[<i>str</i>] ⟩
e. geschenkt (unerg):	⟨ NP[<i>str</i>] ⟩	⟨ NP[<i>str</i>], NP[<i>ldat</i>] ⟩
f. geholfen (unerg):	⟨ NP[<i>str</i>] ⟩	⟨ NP[<i>ldat</i>] ⟩

The forms in (26) differ from those in (8) only in the feature that is used to represent the blocked argument, i.e. SUBJ instead of DA. I assume that the DA of the input lexical sign is also represented at the output lexical sign in addition to the SUBJ value.

Turning to rule (27), the relational constraint *first-np-str* divides the list $\boxed{1}$ in two parts $\boxed{2}$ and $\boxed{3}$. $\boxed{2}$ contains the first NP with structural case, if there is any, and $\boxed{3}$ contains the remaining elements of $\boxed{1}$.

$$(27) \left[\begin{array}{l} \text{SYNSEM|LOC|CAT} \\ \text{HEAD } verb \\ \text{SUBCAT } \boxed{1} \end{array} \right] \mapsto \left[\begin{array}{l} \text{SYNSEM|LOC|CAT} \\ \text{HEAD} \left[\begin{array}{l} \text{VFORM } inf-or-bse \\ \text{SUBJ } \boxed{2} \\ verb \end{array} \right] \\ \text{SUBCAT } \boxed{3} \end{array} \right] \\ \wedge \text{first-np-str}(\boxed{1}, \boxed{2}, \boxed{3})$$

The lexical rule (27) licenses the infinitival forms in (28):

(28)	SUBJ	SUBCAT
a. anzukommen (unacc):	$\langle \text{NP}[_{str}] \rangle$	$\langle \rangle$
b. zu tanzen (unerg):	$\langle \text{NP}[_{str}] \rangle$	$\langle \rangle$
c. aufzufallen (unacc):	$\langle \text{NP}[_{str}] \rangle$	$\langle \text{NP}[_{ldat}] \rangle$
d. zu lieben (unerg):	$\langle \text{NP}[_{str}] \rangle$	$\langle \text{NP}[_{str}] \rangle$
e. zu schenken (unerg):	$\langle \text{NP}[_{str}] \rangle$	$\langle \text{NP}[_{str}], \text{NP}[_{ldat}] \rangle$
f. zu helfen (unerg):	$\langle \text{NP}[_{str}] \rangle$	$\langle \text{NP}[_{ldat}] \rangle$

The lexical rule in (27) ignores the DA value of the input lexical entry. Instead the first argument of the verb that has structural case is represented as SUBJ element in the output sign of (27). Therefore the representation of unaccusative verbs in (26) differ from those in (28).

The stem entries for the auxiliaries have the form in (29) and (30):

$$(29) \text{ werd- (Passive Auxiliary):} \\ \left[\begin{array}{l} \text{HEAD|DA } \langle \rangle \\ \text{SUBCAT } \boxed{1} \oplus \langle \text{V}[_{ppp}, \text{DA } \langle \text{NP}[_{str}]_{ref} \rangle], \text{SUBCAT } \boxed{1} \rangle \end{array} \right]$$

werden selects a participle with a designated argument. Therefore a passivization of unaccusative verbs like *ankommen* and *auffallen* is excluded.

The fronting of the participle together with the subject as in (17) is without problems for this approach, if one assumes that case assignment works as suggested by Meurers (1999): The participle can be combined with all or with some of its arguments. The remaining arguments are taken over by the auxiliary. Since the subject is blocked in the lexical entry for the participle already, the blocking has not to be done by the auxiliary and the conflicts that arise in Kathol's and Pollard's approach do not arise.

The lexical entry for the stem of *haben* in (30) deblocks the designated argument, when a participle is embedded or the syntactic subject which is blocked in the case of *zu* infinitives:

- (30) *hab-* (Perfect Auxiliary and Auxiliary for Modal Infinitive Constructions):
- $$\left[\begin{array}{l} \text{HEAD|DA } \boxed{1} \\ \text{SUBCAT } \boxed{1} \oplus \boxed{2} \oplus \langle \text{V}[\text{ppp-or-inf}, \text{SUBJ } \boxed{1}, \text{SUBCAT } \boxed{2}] \rangle \end{array} \right]$$

The auxiliary *sein* does not unblock blocked arguments:

- (31) *sein* (Perfect Auxiliary and Auxiliary for Modal Infinitive Constructions):
- $$\left[\begin{array}{l} \text{HEAD|DA } \langle \rangle \\ \text{SUBCAT } \boxed{1} \oplus \langle \text{V}[\text{ppp}, \text{SUBCAT } \boxed{1}] \rangle \end{array} \right]$$

The participles of unaccusative verbs like *ankommen* and *auffallen* do not have blocked arguments so that nothing needs to be unblocked in perfect constructions.

I want to complete the analysis by discussing subjectless verbs: A verb like *grauen* ('to dread') does neither have a syntactic subject nor a designated argument. The participle and the infinitive form are represented as follows:

- (32)
- | | SUBJ | DA | SUBCAT |
|------------------------------|-------------------|-------------------|--|
| a. <i>gegraut</i> (unerg): | $\langle \rangle$ | $\langle \rangle$ | $\langle \text{NP}[\textit{ldat}], \text{PP}[\textit{ldat}] \rangle$ |
| b. <i>zu grauen</i> (unacc): | $\langle \rangle$ | $\langle \rangle$ | $\langle \text{NP}[\textit{ldat}], \text{PP}[\textit{ldat}] \rangle$ |

These forms have to be excluded in passive constructions or passive-like constructions:

- (33) a. * *Dem Student wird (vom Professor) vor der Prüfung gegraut.*
the student_{dat} gets by.the professor before the exam dreaded
Intended: '(The professor is threatening so that) the student dreads the exam.'
- b. * *Dem Student ist vor der Prüfung zu grauen.*
the student is before the exam to dread
Intended: 'Somebody has to thread so that the student dreads the exam.'

(33a) is excluded since the lexical entry for *werden* in (29) requires the embedded participle to have a designated argument. To exclude examples like (33b), one has to further specify the lexical entry for the modal *sein*. The modal *sein* has to be specified parallel to the passive auxiliary *werden*: It has to be required that the embedded *zu* infinitive has a referential designated argument.

In contrast to the examples in (33), subjectless constructions are possible in perfect constructions and in raising constructions, as the examples in (34) show:

- (34) a. Dem Student hat vor der Prüfung gegraut.
 the student_{dat} has before the exam dreaded
 ‘The student dreaded the exam.’
- b. Dem Student scheint vor der Prüfung zu grauen.
 the student seems before the exam to dread
 ‘The student seems to dread the exam.’

The lexical rule in (27) produces the right result for the words in (32): Since the SUBCAT list does not contain a NP with structural case, \square is the empty list and hence the SUBJ value of the infinitive form is the empty list. The raising verb *scheinen* (‘seem’) and the perfect auxiliary *haben* just insert the SUBJ value of the embedded verbal complex into their own SUBCAT list. Since the SUBJ value is the empty list in the case of *zu grauen*, nothing is raised.

5 Agent Expressions

In passive constructions, the agent is usually expressed by a PP headed by *von* or *durch*. In lexical rule-based analyses the PP that expresses the agent is often treated as an argument of the passive lexical item (see for example (Pollard and Sag, 1987, p. 216)). As I showed in Section 3.4, treating the agent PP as argument is not possible for auxiliary-based approaches, since the auxiliary had to introduce the agent PP into valence lists and this makes wrong predictions as far as fronting of participles and agent PPs is concerned.

The treatment of the PP as adjunct seems to be the obvious way to solve this problem, but note that sentences like (35) are ungrammatical with the reading where the *von*-PP expresses the logical subject of the participle:⁵

- (35) # Grammatiker haben auch andere Fälle von Grammatikern / sich
 grammarians have also other cases by grammarians self
 angeführt.
 mentioned

Since the participle is assumed to be the same lexical entry in perfect and passive constructions, the *von*-PP can modify the participle in perfect constructions also. In sentences like (35), we therefore have both the logical subject of the active sentence (*Grammatiker*) and the *von*-PP that is used to express the logical subject in passive sentences. Two ways of solving this problem suggest themselves: First, one can assume some version of a coherence principle, as is assumed in LFG (Bresnan, 1982). This principle ensures that every grammatical function of a predicate is realized exactly once. However, it is not easy to see how such a principle could be formalized and integrated into HPSG. The problem is that we cannot refer to grammatical functions. In an HPSG grammar one has valence information and the

⁵‘#’ is used to mark sentences that are ungrammatical with the structure under discussion, but have a reading in which they are grammatical.

dependent elements are linked to the semantic contribution in a certain way. In (35) the NP *Grammatiker* and the PP *von Grammatikern* do not satisfy the same valence requirement, since only the NP is treated as an argument. Since reflexive pronouns in adjuncts may refer to an NP in the same clause, it is impossible to rule out (35) on the basis of the fact that two phrases in the sentence are coindexed with the agent role of *anführen*.

Manning and Sag (1998) discuss a lexical rule-based analysis of the passive and suggest different argument structures for active and passive forms. In an auxiliary-based approach the argument structure would be determined by the auxiliary. It cannot be encoded in the lexical item of the participle since there is just one such item and the binding properties in active and passive sentences differ in the languages discussed by Manning and Sag (1998). In the analysis of sentences like (35) the active argument structure will be used and therefore Binding Theory cannot rule out this example: The *von* PP is just an adjunct PP containing a reflexive, a case that is possible in general and cannot be excluded by Binding Principles.

Höhle (1978, Chapter 7) showed that the expression of the agent is not limited to *von* phrases and that general inference mechanisms and reference to world knowledge are used to infer the agent. Consider the following example from (Höhle, 1978, p. 148):

- (36) Der Verletzte wurde zwischen zwei Sanitätern zum
 the injured was between two first-aid.attendants to.the
 Krankenwagen gebracht.
 ambulance brought
 ‘The injured was brought to the ambulance between two first-aid attendents.’

(36) entails that the first-aid attendents brought him to the ambulance. Examples like (37a) are semantically deviant, since the agent seems to be expressed both in the *von* PP and in the locative PP.

- (37) a. # Der Verletzte wurde von Karl zwischen zwei Sanitätern
 the injured was by Karl between two first-aid.attendants
 zum Krankenwagen gebracht.
 to.the ambulance brought
 ‘The injured was brought to the ambulance by Karl between two first-aid attendents.’
 b. Der Verletzte wurde von Karl zwischen zwei Ziegenböcken zum
 the injured was by Karl between two billy.goats to.the
 Krankenwagen gebracht.
 ambulance brought
 ‘The injured was brought to the ambulance by Karl between two billy goats.’

Nevertheless it would be nice to have a grammar internal way to rule out sentences like (35) without referring to some unformalized inference procedure and there

is a very simple trick that can be used to cope with such examples: One can use the REALIZED feature that was suggested by Przepiórkowski (1999) in connection with case assignment. Raising verbs can only raise elements that are not marked REALIZED+. In our case the constraint on subject raising verbs is shown in (38):

(38) Constraint on Subject Raising Verbs:

$$\left[\text{SUBCAT } \boxed{1} \oplus \boxed{2} \oplus \text{V}[\text{SUBJ } \boxed{1} \textit{list-of-non-realized-synsems}] \right]$$

The agent preposition *von* simply marks the element in the DA list of the modified verb as realized and coindexes the designated argument of the modified verb with the NP that is the argument of the preposition:

(39) Agent Preposition *von*:

$$\left[\begin{array}{l} \text{HEAD} \\ \text{SUBCAT } \langle \text{NP}[\textit{ldat}] \boxed{1} \rangle \end{array} \left[\begin{array}{l} \text{MOD|LOC|CAT|HEAD} \\ \textit{prep} \end{array} \left[\begin{array}{l} \text{DA} \langle \left[\begin{array}{l} \text{LOC|CONT|IND } \boxed{1} \\ \text{REALIZED } \quad + \end{array} \right] \rangle \\ \textit{verb} \end{array} \right] \right] \right]$$

When a *von* PP is combined with the participle, the designated argument is marked as realized. Since the element that is represented under SUBJ is identical to the designated argument (see lexical rule (25)), the element in SUBJ is also marked as realized and since all (subject) raising verbs require the raised elements to be REALIZED–, double realizations of logical subjects as in (35) are correctly excluded.

6 Conclusion

I have developed an analysis of the German passive that for the first time accounts for the passive and for modal infinitives with one lexical item per participle and one lexical item for the *zu* infinitive. In comparison to earlier proposals, the analysis has no problem with partial fronting data.

The analysis is part of a fragment of German, that was implemented with the TRALE system (Meurers, Penn and Richter, 2002).

References

- Askedal, John Ole. 1984. Grammatikalisierung und Auxiliarisierung im sogenannten „bekommen/kriegen/erhalten-Passiv“ des Deutschen. *Kopenhagener Beiträge zur germanistischen Linguistik* 22, 5–47.
- Borsley, Robert D. 1987. Subjects and Complements in HPSG. Report No. CSLI-87-107, Center for the Study of Language and Information, Stanford.

- Borsley, Robert D. 1989. An HPSG Approach to Welsh. *Journal of Linguistics* 25, 333–354.
- Bresnan, Joan. 1982. The Passive in Lexical Theory. In Joan Bresnan (ed.), *The Mental Representation of Grammatical Relations*, MIT Press Series on Cognitive Theory and Mental Representation, pages 3–86, Cambridge: Massachusetts, London: England: The MIT Press.
- Haider, Hubert. 1986. Fehlende Argumente: vom Passiv zu kohärenten Infinitiven. *Linguistische Berichte* 101, 3–33.
- Heinz, Wolfgang and Matiasek, Johannes. 1994. Argument Structure and Case Assignment in German. In Nerbonne et. al. (1994), pages 199–236.
- Hinrichs, Erhard W., Kathol, Andreas and Nakazawa, Tsuneko (eds.). 1998. *Complex Predicates in Nonderivational Syntax*, volume 30 of *Syntax and Semantics*. San Diego: Academic Press.
- Hinrichs, Erhard W. and Nakazawa, Tsuneko. 1998. Third Construction and VP Extraposition in German: An HPSG Analysis. In Hinrichs et. al. (1998), pages 115–157.
- Höhle, Tilman N. 1978. *Lexikalische Syntax: Die Aktiv-Passiv-Relation und andere Infinitkonstruktionen im Deutschen*. Linguistische Arbeiten, No. 67, Tübingen: Max Niemeyer Verlag.
- Kathol, Andreas. 1991. Verbal and Adjectival Passives in German. In Jonathan David Bobaljik and Tony Bures (eds.), *Papers from the Third Student Conference in Linguistics*, volume 14 of *MIT Working Papers in Linguistics*, pages 115–130, Cambridge, Massachusetts: MIT.
- Kathol, Andreas. 1994. Passives without Lexical Rules. In Nerbonne et. al. (1994), pages 237–272.
- Kathol, Andreas. 1998. Constituency and Linearization of Verbal Complexes. In Hinrichs et. al. (1998), pages 221–270.
- Kiss, Tibor. 1992. Variable Subkategorisierung. Eine Theorie unpersönlicher Einbettungen im Deutschen. *Linguistische Berichte* 140, 256–293.
- Lebeth, Kai. 1994. Morphosyntaktischer Strukturaufbau – Die Generierung komplexer Verben im HPSG-Lexikon eines Sprachproduktionssystems. Hamburger Arbeitspapiere zur Sprachproduktion – IV Arbeitspapier Nr. 16, Universität Hamburg, Fachbereich Informatik.
- Manning, Christopher D. and Sag, Ivan A. 1998. Argument Structure, Valance, and Binding. *Nordic Journal of Linguistics* 21(2), 107–144.

- Meurers, Walt Detmar. 1999. Raising Spirits (and Assigning Them Case). *Groninger Arbeiten zur Germanistischen Linguistik (GAGL)* 43, 173–226, <http://ling.osu.edu/~dm/papers/gagl99.html>. 18.04.2000.
- Meurers, Walt Detmar, Penn, Gerald and Richter, Frank. 2002. A Web-based Instructional Platform for Constraint-Based Grammar Formalisms and Parsing. In Dragomir Radev and Chris Brew (eds.), *Effective Tools and Methodologies for Teaching NLP and CL*, pages 18–25, <http://www.ling.ohio-state.edu/~dm/papers/ac102.html>.
- Müller, Stefan. 1999. *Deutsche Syntax deklarativ. Head-Driven Phrase Structure Grammar für das Deutsche*. Linguistische Arbeiten, No. 394, Tübingen: Max Niemeyer Verlag, <http://www.cl.uni-bremen.de/~stefan/Pub/hpsg.html>. 14.11.2003.
- Müller, Stefan. 2001. The Passive as a Lexical Rule. In Dan Flickinger and Andreas Kathol (eds.), *Proceedings of the HPSG-2000 Conference, University of California, Berkeley*, pages 247–266, CSLI Publications, <http://csli-publications.stanford.edu/HPSG/1/>. 11.10.2003.
- Müller, Stefan. 2002. *Complex Predicates: Verbal Complexes, Resultative Constructions, and Particle Verbs in German*. Studies in Constraint-Based Lexicalism, No. 13, Stanford: CSLI Publications, <http://www.cl.uni-bremen.de/~stefan/Pub/complex.html>. 14.11.2003.
- Müller, Stefan. To Appear a. Mehrfache Vorfeldbesetzung. *Deutsche Sprache* <http://www.cl.uni-bremen.de/~stefan/Pub/mehr-vf-ds.html>. 14.11.2003.
- Müller, Stefan. To Appear b. Zur Analyse der scheinbar mehrfachen Vorfeldbesetzung. *Linguistische Berichte* <http://www.cl.uni-bremen.de/~stefan/Pub/mehr-vf-lb.html>. 14.11.2003.
- Nerbonne, John, Netter, Klaus and Pollard, Carl J. (eds.). 1994. *German in Head-Driven Phrase Structure Grammar*. CSLI Lecture Notes, No. 46, Stanford: CSLI Publications.
- Pollard, Carl J. 1994. Toward a Unified Account of Passive in German. In Nerbonne et. al. (1994), pages 273–296.
- Pollard, Carl J. 1996. On Head Non-Movement. In Harry Bunt and Arthur van Horck (eds.), *Discontinuous Constituency*, Natural Language Processing, No. 6, pages 279–305, Berlin, New York: Mouton de Gruyter, veröffentlichte Version eines Ms. von 1990.
- Pollard, Carl J. and Sag, Ivan A. 1987. *Information-Based Syntax and Semantics*. CSLI Lecture Notes, No. 13, Stanford: CSLI Publications.

- Pollard, Carl J. and Sag, Ivan A. 1994. *Head-Driven Phrase Structure Grammar*. Studies in Contemporary Linguistics, Chicago, London: University of Chicago Press.
- Prześciórkowski, Adam. 1999. On Case Assignment and “Adjuncts as Complements”. In Gert Webelhuth, Jean-Pierre Koenig and Andreas Kathol (eds.), *Lexical and Constructional Aspects of Linguistic Explanation*, Studies in Constraint-Based Lexicalism, No. 1, pages 231–245, Stanford: CSLI Publications.
- Ryu, Byong-Rae. 1997. Argumentstruktur und Linking im constraint-basierten Lexikon: Ein Zwei-Stufen-Modell für eine HPSG-Analyse von Ergativität und Passivierung im Deutschen. Arbeitspapiere des SFB 340 Nr. 124, Eberhard-Karls-Universität, Tübingen.

What does it mean to be a complement?

Luis Paris 

University at Albany, SUNY

Jean-Pierre Koenig 

University at Buffalo, SUNY

Proceedings of the 10th International Conference on
Head-Driven Phrase Structure Grammar

Michigan State University

Stefan Müller (Editor)

2003

Stanford, CA: CSLI Publications

pages 298–317

Paris, Luis & Jean-Pierre Koenig. 2003. What does it mean to be a complement?
In Stefan Müller (ed.), *Proceedings of the 10th International Conference on Head-Driven Phrase Structure Grammar*, Michigan State University, 298–317. Stanford, CA: CSLI Publications. DOI: 10.21248/hpsg.2003.17. 

Abstract

This paper shows that the Gerund Phrase (GP) in the Spanish Gerund Construction (e.g., *El jefe entró a su oficina corriendo*, lit. ‘The boss entered his office running’) is sometimes a complement (in SGC_C) and sometimes an adjunct (in SGC_A). Although in both cases, the GP expresses a non-argument of the main lexical verb's denotation, it is a syntactic adjunct in SGC_A and a syntactic dependent of the main clause's head in SGC_C . We argue that there is a semantic correlate of this syntactic difference and propose a general principle that constrains the semantic relations that can hold between the denotata of heads and added members of their ARG-ST lists: The two denotata must be part of a larger macro-event in the sense of Talmy (2000). We further show that the relation between the events denoted by the gerund and main verbs involves four semantic conditions and that which subset of those four conditions are satisfied in a particular SGC_C sentence determines what subkind of SGC_C is involved.

I) Introduction¹

It is typically assumed that semantic argumenthood strongly correlates with syntactic subcategorization. Arguments of the denotation of a word are expressed as its complements or subjects and this information is recorded on lexical entries. Recent work in Head-driven Phrase Structure Grammar has shown that this correlation is looser than often assumed (see Bouma et al. (2001), Przepiokorwki (1998), and Wechsler (1997) among others). For one thing, derived lexical entries can include in their subcategorization (or ARG-ST list) additional elements that do not express a semantic argument (e.g., resultative phrases). For another, a subset of constituents that are traditionally considered to be semantic adjuncts must be subcategorized for by heads, either in the form of additional members of the ARG-ST list or in the form of members of an additional DEPENDENTS list. The latter kind of case leaves it open whether there is a semantic correlate of being an added member of the ARG-ST or DEPENDENTS list of a word. In this paper, we want to discuss one example where it does seem to make a semantic difference, the Spanish Gerund Constructions (SGC). In the first section, we will show that the subtype Complement -or SGC_C - of SGC contains a gerund phrase GP that is a syntactic dependent of the main clause and, hence, should be recorded in the main clause head (i.e. the main verb) despite the fact that it is not a semantic argument of this verb. In the second section we show how the semantics of SGC_C motivates the structural properties of the construction. We suggest a

¹ We would like to thank Bob Levine and Alan Munn for discussing some of the issues in this paper. All remaining errors are ours.

general principle that constrains the semantic relations that can hold between the meaning of verbal heads and the meaning of verbal and predicative complements that are added to their ARG-ST lists.

II) The Spanish Gerund Construction (SGC)

The SGC consists of a main finite clause followed by a gerund phrase (hereafter GP) as represented in sentence (1).

- (1) El niño entró a casa cantando una canción.
The child entered to home singing a song
'The child came home singing a song'

The gerund morphology in Spanish combines with verb roots to form non-finite verb forms that, like its Latin ancestor, may have an adverbial function as in (1) or an adjectival function (i.e. NP modifier) as in (2) We concentrate exclusively on the so-called adverbial use of the gerund in this paper.

- (2) Aquel tipo pintando es mi nuevo profesor.
That guy painting is my new professor
'That guy that is painting is my new professor'

Adverbial uses of the gerund fall into two groups. The GP of one group of SGC is a complement of the main verb. This group is represented by sentence (1). The GP of another group of SGC is a syntactic adjunct. Sentence (3) and (4) illustrate this group. We call these two groups SGC_C and SGC_A, respectively.

- (3) Habiendo vendido el tío la casa, las sobrinas se quedaron sin
having sold the uncle the house, the nieces REF stayed
vacaciones de verano.
without vacations of summer
'The uncle having sold his house, his nieces were left without
summer vacations'
- (4) El profesor se apareció en clase con el pelo rojo,
The teacher REF showed in class with the hair red,
escandalizando a sus alumnos.
scandalizing to his students
'The teacher scandalized his students by showing up in class
with his hair red'

It is important to note that the GP does not encode a semantic argument of the main verb for either SGC_C or SGC_A . The event of singing in sentence (1) does not fill an argument position of the predicate associated with the verb *entrar* ‘enter’ and the gerund phrase or GP is therefore a semantic adjunct. Similarly, the shocking event does not fill an argument position of the predicate associated with the verb *se aparecer* and is a semantic adjunct in sentence (4). What we call SGC_A and SGC_C therefore both involve a phrase, the GP, which does not correspond to a semantic argument of the main verb. We now show that the two groups of SGC differ in that the phrase which is a semantic adjunct for both SGC_A and SGC_C appears to be a morphosyntactic complement in one case, but not the other.

Descriptively, SGC_A and SGC_C differ in several respects. For example, the clauses in SGC_A are typically separated by a pause –as the comma graphically indicates in (3)- whereas the insertion of a pause in the example of SGC_C in (2) makes the sentence ungrammatical (the presence of a pause is again graphically represented via a comma in (5)).

- (5) *El niño entró a casa, cantando una canción.
 The child entered to home singing a song
 ‘The child came home singing a song’ (intended meaning)

Further, SGC_A allows the GP to have an independent subject whereas SGC_C is an obligatory control structure, as the contrast between (3) and (6) shows.

- (6) *El niño entró a casa su padre cantando una canción.
 The child entered to home his father singing a song
 ‘The child came home while his father was singing a song’
 (intended meaning)

These two surface differences indicate that SGC_A patterns like a typical complex sentence with an embedded adverbial clause –such as *cuando* ‘when’ clauses, whereas SGC_C patterns like obligatory control complement VPs. Note that control in the case of SGC_C is obligatory but not fixed. As sentence (7) shows, the direct object of the main verb can control the reference of the unexpressed subject of the GP. Sentence (8) shows further that only subjects and direct objects but not indirect object can be controllers.

- (7) Tu vecino trajo a María_i llorando_j.
 your neighbor brought to María crying
 ‘María was crying when your neighbor brought her’
- (8) María_i le dió el libro a Pedro_j gritando_{i/*j}.
 María him gave the book to Pedro screaming
 ‘María was screaming when she gave Pedro the book’

More compelling evidence for the hypothesis that the GP occurs in different structural positions in SGC_C and SGC_A comes from data pertaining to the reordering of post-verbal constituents. The GP and indisputable complements can be reordered without information-structure consequences in the case of SGC_C , but not in the case of SGC_A , as the contrast between sentences (9) and (10) shows.

- (9) Los estudiantes cruzaron corriendo la plaza.
 The students crossed running the square
 ‘The students crossed the square running’
- (10) *Pedro ganó, contando con un estipendio para viajes, la beca.
 Pedro won, having with a stipend for travel, la beca.
 ‘Pedro won the scholarship even having money for travel’

Under standard assumptions that only reordering of sister constituents does not require a particular information structure, the grammaticality of sentence (9) and similar SGC_C sentences suggests that the GP is a sister to the post-verbal complements in SGC_C . Conversely, the ungrammaticality of sentence (10) suggests that the GP is not a sister to the post-verbal complements in SGC_A .

Extraction data confirm the difference in complement status of the two kinds of SGC. Simply put, the direct object or other post-verbal complements of the gerund can be extracted from within the GP in the case of SGC_C , but not SGC_A as the contrast between sentence (11) and (12) illustrates. Sentence (13) further shows that SGC_A patterns with other adverbial clauses, which equally ban extraction of constituents from within adjunct clauses.

- (11) ¿Qué volvieron los niños cantando?
 What came.back the children singing
 ¿What did the children come back singing?

- (12) *¿Habiendo vendido el tío, qué las sobrinas se quedaron sin
 having sold the uncle, what the nieces REF stayed without
 vacaciones?
 vacations
 ‘What did the uncle sold leaving his nieces without summer
 vacation? (intended)
- (13) *¿ Qué María salió cuando compró ?
 what María exit when bought-3s
 ‘What did she buy when she went out?’ (intended meaning)

The contrast between (11) and (12) only argues that the GP is a complement in the former sentence, but not the latter, in theories such as that presented in Bouma, Malouf, and Sag (2001) in which only syntactic dependents (or syntactic dependents of syntactic dependents...) can be extracted. In a Barriers-style analysis (Chomsky (1986), Rizzi (1990)) or in Pollard and Sag’s (1994) HPSG analysis of extraction, extractability does not entail dependency. Although extraction (of complements) from within adjuncts might involve a mild subjacency violation in a Barriers-style analysis, extraction is not restricted to dependents (of dependents...). The relevance of the contrast between (11) and (12) to the complement status of the GP is therefore partially theory-internal. But, note first that a Barriers-style or Pollard and Sag-style analysis of extraction cannot easily capture the contrast between (11) and (12), since both sentences would involve a semantic *and* syntactic adjunct. Sentences (14)-(16) show that the contrast extends to other filler-gap constructions (relative clauses, cleft, and pseudo-clefts) and is not restricted to questions. Again, a Barriers-style or Pollard and Sag-style theory of extraction cannot easily capture the contrast.

- (14) La canción que los niños volvieron cantando era muy antigua.
 the song that the children came-back singing was very old
 'The song the children came back singing was very old'
- (14’) *Su ideología que los cursos difícilmente se llenan de
 Her/His ideology that the classes hardly REF fill of
 estudiantes conociendo
 students knowing
 (*)'His ideology that his classes get hardly full the students
 knowing'

- (15) Era una canción lo que los niños volvieron cantando.
Was a song it that the children came-back singing
'It was a song that Pedro came back singing (lit.)'
- (15') *Era su ideología lo que las clases difícilmente se llenan
Was her/his ideology that the classes hardly REF fill
los estudiantes conociendo.
knowing the students
(*)'It was his ideology that his classes get hardly full the
students knowing'
- (16) Lo que los niños volvieron cantando fue una canción.
It that the children came-back singing was a song
'What the children came back singing was a song (lit.)'
- (16') *Lo que las clases difícilmente se llenan los estudiantes
It that the classes hardly REF fill the students
conociendo es su ideología.
knowing is his ideology
(*)'What the classes get hardly full the students knowing is his
ideology'

Second, only Bouma, Malouf, and Sag's theory of extraction can explain why extraction differences parallel reordering differences. Both differences are indicative of a difference in syntactic dependency status. In contrast, a more traditional analysis of extraction would leave unaccounted for why complements of the gerund verb can only be extracted from GPs that can be reordered with the main verb's complements. While not uncontroversially supportive of the claim that the GP is a complement of the main verb in SGC_C , the extraction data partially confirms other pieces of evidence we provided to support our hypothesis. We conclude that the preponderance of the evidence supports the claim that the GP is a syntactic complement of the main verb in SGC_C , but a syntactic adjunct in the case of SGC_A .

One way to explain the data we have presented so far would be to hypothesize that the main and the gerund verbs form a complex predicate. This hypothesis is particularly relevant since it is well-known that complex predicates exist in Romance and Spanish (Aissen and Perlmutter 1983). However, when standard tests of complex predicate formation are applied, it can be seen that SGC_C does not behave as a complex predicate structure. For example, it is standard to assume that

so-called clitic climbing is possible in complex predicate structure, as shown in (17) for the Spanish causative construction.

- (17) El jefe lo hizo lavar por el empleado del taller.
The boss it made wash by the employee of-the repair-shop
'The boss had it washed by the repair-shop employee'

In contrast, sentence (18) shows that clitic climbing is not possible with SGC_C .

- (18) *El intendente lo salió del garage manejando.
The major left from-the garage driving
'The major took it out from the garage driving' (intended)

Furthermore, complex predicate allows anaphoric binding across predicates as shown in (19)

- (19) El jefe_i se_i hizo afeitar por Pedro.
the boss_i REF_i made shave by Pedro
'The boss made Pedro shave him'

whereas SGC_C does not allow a reflexive to be bound by an argument of the main predicate.

- (20) *El profesor se llegó peinando.
the professor REF arrived combing
'The professor was combing when he arrived' (intended)

In conclusion, we have shown that the GP in SGC_C behaves as a complement phrase of the main verb and that the gerund and main verbs do not form a complex predicate. We conclude that the GP should be listed in the ARG-list (or equivalently, the DEPENDENTS list) of the main verb so as to license the extraction of its complements as well as the control of its subject. We represent the class of *sgc-verb* in (21), which reads as follows. The class of *sgc-verb* includes on its ARG-ST list the members of the ARG-ST list of their root or stem plus a gerund phrase. (See Koenig (1999) for more details on this representation of word-internal structure. An essentially identical representation of that verb class can easily be provided through the use of lexical rules.)

$$(21) \left[\begin{array}{l} sgc-verb \\ ARG-ST \quad [1] \oplus \langle GP \rangle \\ \mu-DGHTR \quad [1] \end{array} \right]$$

III) The semantic motivation

a. The mereological constraint

Given that the gerund phrase is a dependent of the head verb in SGC_C and an adjunct in SGC_A , the question is whether this difference in dependency status has any semantic concomitant. We propose here that there is a semantic motivation for this difference in dependency status: SGC_C expresses a mereological relation between two eventualities that constitute a single macro-event. This constraint is part of a cross-linguistic correlation between the tightness of syntactic bond between verbs or other predicators and the type of semantic relation those verbs or predicators' denotations entertain (Van Valin and LaPolla (1997)). We describe the syntax-semantics interface condition that underlies the difference between SGC_A and SGC_C as follows.

Mereological Condition on Added Predicative Arguments (MCAPA): The denotations of a head and added verbal or predicative members of its ARG-ST list must be parts of a larger macro-event.

More generally, this condition suggests that event relations motivate the addition of members to the ARG-ST list of "base" entries. It contrasts with the constraint put forth in Rapaport and Levin 2001, who suggest that temporal relations can motivate the addition of members to the ARG-ST list of "base" entries. Their constraint states that the denotation of English resultative phrases and the heads they complement need only stand in a temporal dependency.

This section shows how the MCAPA principle determines the encoding of various subtypes of SGC_C . There are several subkinds of SGC_C ; each one is characterized by a particular instantiation of the mereological constraint. The first subkind is $SGC_{C-MEANS}$ represented by sentence (22).

- (22) El jefe entró a su oficina corriendo.
the boss entered to his office running

‘The boss ran into his office’

To model the semantics of (22), we borrow the notion of a macro-event and its two component events, the framing event and the co-event from Talmy (2000). In a sentence describing motion, the macro-event is described by the verb which encodes the change of location (the inward crossing of an enclosure’s boundary for *entrar* in (22)) and the co-event is described by the verb which encodes the manner of locomotion (the particular pattern of leg motion for *corriender* in (22)).² The two events, the framing and the co-event can be, according to Talmy, related through a small set of support relations. For sentences such as (22), he calls this support relation, MANNER. The existence of a macro-event, in Talmy’s terms, insures that sentence (22) satisfies the MCAPA: The entering event e_M is a (non-necessarily proper) subpart of a macro-event e_Z and the running event e_G is also a subpart of e_Z .

Talmy does not specify thoroughly what the MANNER support relation consists of. A detailed list of what is shared between the events of entering and running in sentence (22) might help clarify what this relation is. The set of conditions in (24) provides such a list.

- (24)
- a. The two events share participants (e.g. in (22), the moving Figure).
 - b. This participant is shared in relation to overlapping spatio-temporal frames.
 - c. The two events unfold “together”: Progress on the path maps onto a greater number of leg motions, so to speak.
 - d. The two events are in the same causal path and share time intervals (in the case of (22), the manner of locomotion causes the change of location).

Our hypothesis is that conditions a.-c. are present whenever two events are related within a macro-event through a MANNER support relation. The addition of condition d. or some variant of it defines what we call an *intrinsic manner* relation, which sentence (22) and other sentences that are instances of $SGC_{C-MEANS}$ illustrate.

Sentence (25) is a further example of $SGC_{C-MEANS}$.

² More precisely, as we discuss below, the verb *entrar* lexically encode both the framing and co-event, i.e. the entire macro-event, whereas *corriender* only encodes the manner of locomotion co-event.

- (25) El tenor canta gritando.
 The tenor sings screaming
 ‘The tenor screams when he sings’

The singing event in sentence (25) denotes the macro-event. The framing event is the creation of a melody with accompanying words and the co-event which causes it is the emission of sound. The GP further specifies the general sound emission event encoded in *cantar*.

A second subkind of SGC_C is SGC_{C-AGG} illustrated in sentence (26). The dreaming event e_G in (26) is a proper part of the sleeping event e_M . Sleeping involves, among other components, unconscious mental activities, one of which can be dreaming. The MCAPA is again satisfied, since e_G is a part of e_M . Conditions a. and b. (24) are satisfied. Condition c. is satisfied, at least for those times when Maria dreams (see SGC_{C-CIRC} for other cases in which condition c. is only satisfied modulo asymmetric interruptions of e_G and e_M). Condition d. holds, but in contrast to $SGC_{C-MEANS}$, it is the framing event (the sleeping) that enables the co-event (the dreaming), rather than the co-event causing the framing event.

- (26) María durmió toda la noche soñando con insectos.
 Maria slept all the night dreaming with insects
 ‘Maria dreamt of insects the entire night.’

Sentence (27) illustrates a third subkind of SGC_C , which we call $SGC_{C-CAUSE}$. In sentence (27), the main event e_M again describes a complex macro-event and involves two subeventualities, a causing eventuality e_B and a change of state e_C result. But in this case, rather than the gerund e_G specifying further the effect e_C , e_G specifies further the cause e_B : Jumping over the fence caused the change the state of the public.

- (27) El potro sorprendió al público saltando el corral.
 The stallion surprised to-the public jumping-over the corral
 ‘The stallion surprised the spectators by jumping over the fence’

The defining characteristic of $SGC_{C-CAUSE}$ is that its main verb is a lexical causative verb. We assume with all lexical decomposition analyses that lexical causatives involve two subeventualities, an activity and a change of state and claim that the GP in $SGC_{C-CAUSE}$ always

specifies the activity that leads to the result state. Again, the surprise and the jumping events are part of a larger macro-event, as required by the MCAPA. The surprise denotes the macro-event and is trivially a part of itself, and the GP denotes a proper subpart of e_M . The events described by the main and gerund verbs in (27) also satisfy conditions a., b., and d. in (24). But, note that, in contrast to what was the case with sentence (22), (25), or (26), condition c. does not hold. There is no parallel progression between e_M and e_G (even modulo interruptions). We call the semantic relation involved in $SGC_{C-CAUSE}$ *internal cause*.

An analogous analysis applies for every SGC_C whose main verb is a causative verb. For example, *memorize*'s denotation in (28) includes both a causing process and a change of state as subparts. The re-reading event expressed by the gerund phrase causes a change by which the poem is placed in Julia's memory/mind and, hence, a change of mental state in Julia.

- (28) Julia memorizó el poema releýendoló una y mil veces.
 Julia memorized the poem re-reading-it one and thousand times
 ‘Julia memorized the poem by re-reading it one time after another’

b. The asymmetry constraint

Characterized solely in terms of inclusion of e_G and e_M in a macro-event e_Z , the semantics of $SGC_{C-MEANS}$, SGC_{C-AGG} , and $SGC_{C-CAUSE}$ assigns an apparent identical role to e_M and e_G . That is, both e_G and e_M are part of the macro-event and thus play identical roles with respect to that macro-event. We would predict then that e_M and e_G can be expressed equally well as main verbs or gerund verbs. However, this is not the case. In fact, a fundamental feature of SGC_C is that there is an asymmetry between the event descriptions encoded as the main VP and the GP. Sentences (29) and (30) reverse the encoding of e_M and e_G in sentences (22) and (27), respectively; in turn, sentence (31) reverses the encoding of e_M and e_G in (26).

- (29) #El jefe corrió entrando a su oficina.
 The boss ran entering to his office
 ‘The boss ran while entering his office’³ (intended meaning)

³ Sentence (25) is acceptable if a pause is inserted between the clauses. The pause turns (25) into an instance of SGC_A and, rather than *intrinsic manner*, the sentence then has a *consequence* interpretation (see Paris (2003) for details).

- (30) #El potro saltó el corral sorprendiendo al público.
 The stallion jumped the fence surprising to-the public
 'The stallion jumped over the fence thereby surprising the spectators' (intended)
- (31) #El tenor grita cantando.
 The tenor screams singing
 'The tenor screams when he sings' (intended meaning)

These sentences are semantically odd, which suggests that given any two events, if they are in an *intrinsic manner* or *internal causal* relation, only one of them can be expressed in the main clause whereas the other needs to be expressed as a GP. Since the notion of subpart does not differentiate between e_M and e_G , we propose that the asymmetry in $SGC_{C-MEANS}$, SGC_{C-AGG} , and $SGC_{C-CAUSE}$ arises from the fact that the main verb must denote the entire macro-event in Talmy's sense, whereas the GP only describes the co-event of that macro-event. *Entrar*, for example, describes a specific change of location caused by an unspecified manner of locomotion. The semantic content of *corriender* further specifies this manner of locomotion. Similarly, *singing* describes the creation of a melody with accompanying words resulting from the emission of a sequence of sounds of unspecified quality; *gritar*, then, further specifies the rather poor quality of those sounds. The reader can easily verify that the same macro event vs co-event asymmetry applies to other examples of $SGC_{C-MEANS}$, SGC_{C-AGG} , or $SGC_{C-CAUSE}$ we have presented. We summarize the semantic asymmetry between the main verb and the GP below.

Semantic asymmetry in $SGC_{C-MEANS}$, SGC_{C-AGG} , and $SGC_{C-CAUSE}$:
 The main verb describes the whole macro event of an event complex; the GP only describes its co-event subpart. The GP is a more specific description of the co-event than that provided by the main verb.

c. An extended subkind of SGC_C

The fourth subkind of SGC_C is SGC_{C-CIRC} , which sentence (1), repeated below, illustrates. It does not satisfy the semantic asymmetry we just mentioned. The basic semantic property that differentiates SGC_{C-CIRC} from $SGC_{C-MEANS}$, SGC_{C-AGG} , and $SGC_{C-CAUSE}$ is that the former involves events in divergent causal paths whereas the events described in the latter are in the same causal path.

- (1) El niño entró a casa cantando una canción.
 The child entered to home singing a song
 ‘The child came home singing a song’

The entering event e_M in (1) is performed by an agent that also performs the singing event e_G at the same spatio-temporal circumstance (i.e. e_G and e_M are associated with overlapping time intervals). But there is no causal link between e_G and e_M . Neither one causes or enables the other event or the effect that is part of the other event. This description may suggest that SGC_{C-CIRC} merely encodes a temporal relation between e_G and e_M ; the two events, not being causally connected are merely temporally connected. In the following paragraphs, we argue that, as we claim is required of all instances of SGC_C , SGC_{C-CIRC} , *does* encode a mereological relation and that, in conformity to the MCAPA, both e_G and e_M are subparts of a larger, macro-event ('enter singing' in (1)).

The grammatical behavior of SGC_{C-CIRC} contributes several pieces of evidence that support the conclusion that the construction denotes a single (complex) event. The first one is the presence of a semantic asymmetry (of a different kind than the one we discussed for $SGC_{C-MEANS}$, SGC_{C-AGG} , and $SGC_{C-CAUSE}$). Sentences (32) and (33) are both instances of SGC_{C-CIRC} ; in the former the cooking event e_M and the watching event e_G are performed by the same individual (i.e. Pedro) at overlapping temporal intervals and places. In sentence (33), the driving and the smoking events are also performed by the same individual at overlapping temporal intervals and places.

- (32) Pedro cocinó el pollo mirando TV.
 Pedro cooked the chicken watching TV
 ‘Pedro watched TV while cooking the chicken’
- (33) Manejó a casa fumando un cigarrillo.
 Drove to house smoking a cigarette
 ‘S/he drove home smoking a cigarette’

If the SGC_{C-CIRC} merely encoded the presence of a temporal overlap between e_G and e_M , one would predict the reverse encoding of e_G and e_M to be possible, since overlap is a symmetric relation. The semantic oddity of sentences (34) and (35), which correspond to sentences (32) and (33), respectively, shows this prediction is incorrect.

- (34) # Pedro miró TV cocinando el pollo
 Pedro watched TV cooking the chicken
 ‘Pedro cooked the chicken watching TV’ (intended meaning)
- (35) #Fumó un cigarillo manejando a casa.
 Smoked a cigarette driving to house
 ‘S/he drove home smoking a cigarette’ (intended meaning)

The oddity of these sentences suggests that the relation between the two events or event descriptions is asymmetric; hence, whatever this relation is, it cannot be mere temporal overlapping since this latter relation is symmetric; it must be a relation that assigns specific roles to e_M and e_G with which each event may or may not be consistent.

The second piece of evidence is that an SGC_{C-CIRC} sentence can be an answer to a *Cómo* ‘How’ question –as shown in (36’), which is a legitimate answer to (36).

- (36) ¿Cómo llegó Pedro a casa?
 How arrived Pedro to home
 ‘How did Pedro come home?’
- (36’) Llegó cantando tangos.
 arrived-3sg singing tangos
 ‘He came home singing a tango’

SGC_{C-CIRC} parallels $SGC_{C-MEANS}$, in this respect. Instances of $SGC_{C-MEANS}$ can also answer felicitously a ‘how’ question as shown by (37’), which is a possible answer to question (37’).

- (37) ¿Cómo caminó el jefe por el pasillo?
 How walked the boss through the hallway
 How did the boss walk through the hallway?
- (37’) El jefe caminó rengueando por el pasillo.
 the boss walked limping through the hallway
 ‘The boss limped down the hallway’

In both cases, the interrogative *Cómo* treats the GP as providing more than temporal information, intuitively, something like the manner in which the action was performed. Corroboration of this hypothesis comes

from the fact that, although sentences (34) and (35) are acceptable answers to a ‘when’ question as sentences (38) and (38’) show, they are unacceptable as an answer to a ‘how’ question. As Paris (2003) argues, SGC_A is often used to indicate the presence of a temporal overlap between e_G and e_M and we thus interpret the felicity of (38) and (38’) as indicative that (38’) is an instance of SGC_A (see Paris (2003) for further arguments that (38’) is indeed an instance of SGC_A). In other words, sentences which are not instances of SGC_{C-CIRC} cannot be answers to a ‘How’ question; they can be answers to a ‘When’ question, provided they are analyzed as SGC_A structures. These data further suggest that SGC_{C-CIRC} requires more than a temporal relation between e_G and e_M .

(38) ¿Cuándo miraste televisión?
When watched television
When did you watch TV?

(38’) ¿Cuándo fumaste un cigarillo?
When smoked a cigarette
'When did you smoke a cigarette?'

Adverb modification provides a third piece of evidence in favor of the presence of a macro-event. The adverb *perfectamente* ‘perfectly’ in (39) can be interpreted as conveying a property of the ‘cook-watching-TV’ event as a whole rather than modifying only ‘cook’ or ‘watch’.

(39) Pedro cocina mirando TV perfectamente.
Pedro cooks watching TV perfectly
'Pedro cooks watching TV perfectly'

Sentence (39) does not necessarily entail that Pedro's cooking excels nor that his watching TV excels. The adverbial modification has a reading in which it introduces a contrast set that contains Pedro's cooking events that do not involve watching TV. In that interpretation, ‘perfectly’ does not qualify any property intrinsic to Pedro's cooking; it rather says that Pedro cooks watching TV as well as he does when he is not watching TV. In that reading, *perfectamente* modifies the macro-event of ‘cooking-watching-TV’. This type of modification is not possible with typical adverbial clauses as shown in sentence (40).

(40) Pedro cocina (perfectamente) mientras mira TV (?perfectamente).
Pedro cooks (perfectly) while watches TV (?perfectly)
'Pedro cooks fine while watching TV'

In this case *perfectamente* only modifies cooking and entails that the cooking was perfect.

A fourth piece of evidence indicating that SGC_{C-CIRC} describes a single macro-event, as required by the MCAPA, is given by the fact that only stage-state predicates (dynamic states in Bach's (1986) terminology) can be felicitously used in SGC_C . Individual state predicates cannot show up neither as main verbs (e.g., sentence (42)) or as heads of the gerund phrase (e.g., sentence (43)).

(42) #Mi tío odia el Otoño barriendo las hojas.
My uncle hates the Fall raking the leaves
'My uncle hates Fall while he is raking the leaves'

(43) #Pedro vino de Brasil siendo inteligente.
Pedro came from Brazil being smart

In contrast, stage-state level predicates are felicitous either as main verbs (e.g., (44)) or as gerund verbs (e.g., sentence (45)).

(44) El paciente parecía triste contando su historia.
the patient seemed-IMP sad telling her/his story
'The patient looked sad while telling his story'

(45) Pedro firmó ese cheque estando ebrio.
Pedro signed that check beingdrunk
'Pedro signed out that check drunk'

Again, if mere temporal overlap was required of e_G and e_M , we would not expect restrictions on the Aktionsart of e_G and e_M .

We take the four pieces of evidence we presented to support the claim that the relation between e_G and e_M is more than temporal. To determine the nature of this relation, we rely on the fact that an SGC_{CIRC} sentence can answer a 'How' question as well the fact that the meaning of sentence (1) can be paraphrased as *entrar cantando es una manera de entrar* 'enter singing is a way entering'. The way-of paraphrase is possible for every instance of SGC_{C-CIRC} ; for example, a way-of paraphrase for sentence (32) is *cocinar mirando TV es una manera de cocinar* 'to cook watching TV is a way of cooking' and a way-of paraphrase of (33) is *manejar fumando es una manera de manejar* 'to

drive smoking is a way of driving'. In contrast, this paraphrase is not possible for (34) (*#mirar TV cocinando es una manera de mirar TV* 'to watch TV cooking is a way of watching') or sentence (35) (*#fumar manejando es una manera de fumar* 'smoke driving is a way of smoking'). We view the 'way-of' and 'how' data as indicative of the presence of what we call an *extrinsic manner* relation between e_M and e_G . We propose that if a sentence is an instance of SGC_{CIRC} , e_M and e_G are both part of a macro-event and, further, the activity that constitutes e_M is the agent's main goal and the activity that constitutes e_G is incidental to this main goal. This distinction between the main and incidental activities accounts for the asymmetry of the descriptions of e_G and e_M . Note that the relation between e_G and e_M in SGC_{C-CIRC} satisfies conditions a.-c. in (24). Leaving aside interruptions in one activity but not the other (Pedro stopped cooking for a while, but still watched TV during that time), the cooking and watching go hand in hand. For every subevent of cooking, there corresponds a subevent of watching. But, in contrast to other subkinds of SGC_C , e_G and e_M in SGC_{C-CIRC} do not satisfy condition d. in (24), since e_G and e_M do not belong to the same causal path. The fact that SGC_{CIRC} sentences satisfy three of the four conditions in (24) suggests that the relation between e_G and e_M in SGC_{CIRC} is similar to the relation exhibited by the corresponding events in $SGC_{C-MEANS}$ and SGC_{C-AGG} , what we call *manner*. The fact that condition d. does not hold motivates our use of the term *extrinsic manner*.

Our analysis of the semantics of SGC_{C-CIRC} builds in an asymmetry between e_G and e_M that reflects the reverse encoding data. But, ultimately, the factors determining which event is the main event and which other concurrent event is incidental in an event pair is a matter of world knowledge. We can only point to some patterns; for example, given a motion event and a non-motion activity, only the non-motion event can be incidental; more generally, telic event descriptions cannot denote an event incidental to the one described by a non-telic event description (Talmy (2000) makes a similar observation with respect to what we call SGC_{MEANS}), as sentences (47) and (48) show.

- (47) El maestro corrigió exámenes escuchando música.
the teacher graded tests listening music
'The teacher graded homework listening to music'
- (48) #El maestro escuchó música corrigiendo exámenes.
the teacher listened music grading tests

'The listened to music while grading the tests'

To sum up this section, we have argued that SGC_C requires e_G and e_M to be parts of a macro-event that are related through a support relation. In the prototypical examples of SGC_C , this relation can be explicated through four conditions (see (24)). When all four conditions are satisfied, as is the case for, $SGC_{C-MEANS}$ and SGC_{C-AGG} , the support relation is what we call *intrinsic manner*. When only conditions a.-c. are satisfied, as is the case for SGC_{C-CIRC} , we talk of an *extrinsic manner* relation. Finally, when conditions a.-b., and d. are satisfied, as is the case for $SGC_{C-CAUSE}$, we talk of *internal cause* support relation.

IV) Conclusion.

This paper has shown that the Gerund Phrase (GP) in the Spanish Gerund Construction (SGC) is sometimes a complement (in SGC_C) and sometimes an adjunct (in SGC_A). In both cases, the GP expresses a non-argument of the main verb's denotation; but, it is a syntactic adjunct in SGC_A whereas it is a syntactic dependent of the main clause's head in SGC_C . It has been observed before that, cross-linguistically, the degree of syntactic dependency between two event-denoting expressions, is proportional to the strength of the semantic relation joining the events. We have shown that this proportion holds for SGC_C since the dependent status of GP in SGC_C correlates with the existence of a mereological relation connecting the events expressed by GP and the main clause to a larger macro-event. Drawing on the work of Talmy (2000), we have analyzed the relation between the events denoted by the gerund verb and main verb through four semantic conditions. Which subset of those four conditions are satisfied in a particular SGC_C sentence determines what subkind of SGC_C is involved.

References:

- Bouma, Gosse, Robert Malouf and Ivan Sag. 2001. Satisfying constraints on extraction and adjunction. *Natural Language & Linguistic Theory* 19:1 1-65.
- Chomsky, Noam. 1986. *Barriers*. Cambridge, MA: MIT Press.

- Ernst, Thomas. 2000. Manners and Events. In Carol Tenny and James Pustejovsky (eds.) *Events as Grammatical Objects*. Dordrecht: Kluwer.
- Hukary, Thomas and Levine, Robert. 1995. Adjunct extraction. *Journal of Linguistics* 31: 195-226.
- Koenig, Jean-Pierre. 1999. *Lexical Relations*. Stanford: CSLI Publications.
- Manning, Christopher, and Ivan Sag. 1998. Dissociations between argument structure and grammatical relations. *Lexical and constructional aspects of linguistic explanation*, ed. by Gert Webelhuth, Jean-Pierre Koenig, and Andreas Kathol. Stanford: CSLI Publications.
- París, Luis, 2003. The grammatical encoding of event relations: Gerund Phrases in Spanish. University at Buffalo, the State University of New York dissertation.
- Pollard, Carl, Ivan Sag. 1994. *Head Driven Phrase Structure Grammar*. Chicago: The University of Chicago Press.
- Przepiórkowski, Adam, 1999. Case Assignment and the Complement/Adjunct Dichotomy. Tübingen: Universität Tübingen dissertation.
- Rappaport Hovav, Malka, and Beth Levin. 2001. An event structure account of English Resultatives. *Language* 77.766–797.
- Rizzi, Luigi. 1990. *Relativized Minimality*. Cambridge, MA: MIT Press.
- Stump, Gregory, 1981. The formal semantics and pragmatics of free adjuncts and absolutes in English. Ohio State University dissertation.
- Talmy, Leonard. 2000. *Toward a Cognitive Semantics*. Cambridge, MA: MIT Press. 5
- Van Valin, Robert, and Randy LaPolla. 1997. *Syntax: Form, Meaning, and Function*. Cambridge: Cambridge University Press.
- Wechsler, Stephen. 1997. Resultative predicates and control. *Texas linguistic forum 38: The syntax and semantics of predication*, ed. by R. Blight and M. Moosally, 307–321. University of Texas at Austin: Texas Linguistic Forum 6

In search of epistemic primitives in the English Resource Grammar (or Why HPSG can't live without higher-order datatypes)

Gerald Penn 
University of Toronto

Kenneth Hoetmer
University of Toronto

Proceedings of the 10th International Conference on
Head-Driven Phrase Structure Grammar

Michigan State University

Stefan Müller (Editor)

2003

Stanford, CA: CSLI Publications

pages 318–337

Penn, Gerald & Kenneth Hoetmer. 2003. In search of epistemic primitives in the English Resource Grammar (or Why HPSG can't live without higher-order datatypes). In Stefan Müller (ed.), *Proceedings of the 10th International Conference on Head-Driven Phrase Structure Grammar*, Michigan State University, 318–337. Stanford, CA: CSLI Publications. DOI: 10.21248/hpsg.2003.18. 

Abstract

This paper seeks to improve HPSG engineering through the design of more terse, readable and intuitive type signatures. It argues against the exclusive use of IS-A networks and, with reference to the English Resource Grammar, demonstrates that a collection of higher-order datatypes are already acutely in demand in contemporary HPSG design. Some default specification conventions to assist in maximizing the utility of higher-order type constructors are also discussed.

1 Introduction

Types are good to have around. Not only do they assist in compile-time error detection and efficient run-time code generation, but they have the ability to reflect the grammar designer's perspective or intuitions about constructs within the grammar, simply by their presence in the source code as names/labels. They also make grammars more modular. In particular, to take the classical view on this topic from the theory of programming languages, types are what mediate communication between modules. Within the logic of typed feature structures, types can also serve as an alternative to structure sharing in complex descriptions, which can often be difficult to conceptualize or debug. This essentially enforces a kind of modularity on descriptions.

In HPSG, types are related by subtyping, otherwise known as the IS-A relation, and this relation is interpreted as subset inclusion. Many of the early attempts at developing knowledge representations in the 1960s posited perfectly reasonable relations among their concepts when viewed in isolation, but they were unsuccessful in the long term because there were no systematic principles at work across those different attempts — principles that anyone else could adhere to and by which they could understand how to reuse and modify those resources. This point was demonstrated quite convincingly by Brachman with his work on the KL-ONE system [Brachman, 1977]. This work ultimately led to a large number of conceptual reasoning systems that were able to automate certain forms of inference by exploiting the semantic properties of a small number of primitives used for organizing knowledge. Foremost among those primitives was IS-A, which has also since formed the backbone of class relationships in many object-oriented programming languages with subtyping [Ait-Kaci, 1984]. It was from this trend that HPSG took its initial inspiration in employing types with inheritance [Pollard, personal communication]. In HPSG, this same partial order defines how types inherit features.

In the intervening 20 or so years, however, there have been a number of further developments in the type systems of both description logics and the theory of programming languages that have largely passed grammar development in HPSG by — although there has been no shortage of more theoretical work on the connections among formal grammar, type theory and category theory. There has been a recent trend in HPSG towards using types (rather than features) wherever possible

to encode distinctions among information states in signatures. The reasoning given has generally been consistent with the benefits mentioned above, e.g., greater efficiency without loss of elegance [Flickinger, 2000], but the down-side of this trend, that simple types can mediate only simple communication, has not received much attention or redress. HPSG’s almost exclusive use of IS-A is a very simple type system indeed. The only “method,” again to appeal to programming languages terminology, is unification, or the least upper bound operation.¹ In the case of the English Resource Grammar (ERG), this least upper bound is taken relative to a signature with between 2,000 and 10,000 types, depending on how one counts, and this is anything but modular to work with.

The present research programme began with an attempt to determine whether simple HPSG-style typing, while it may not be modular, has performed adequately in its other role of capturing and accentuating the intuitions of the ERG’s designers. Although we were not the designers, our extensive study of the ERG type signature has forced us to conclude that it has not. In what follows, we seek to contribute the missing grammar-development-oriented perspective on the potential for using a richer set of typing constructors in HPSGs, in part by enumerating a collection of higher-order datatypes that are provably “in demand.” This proof takes the form of references to (in places, simplified) examples from the ERG signature,² in addition to a discussion of conventions that will assist in maximizing their utility.

Specifically, we observe the informal but routine use of the following higher-order constructors among the types of the ERG:

1. parametric products,
2. optionality,
3. Smyth powerdomains,
4. purity / strictness,
5. finite domains.

We discuss several default specification conventions (not to be confused with default unification) as well as a further generalization of the proposals made by Erbach [1994] and Penn [1998] for embedding these constructions into larger type hierarchies.

There are probably other higher-order constructors worth using — we do not intend this to be a closed class. None of the constructors enumerated above, moreover, should come as a surprise. Parametric types have been used in Pollard and

¹Breaking with the ERG literature’s convention of writing more specific types below their more general supertypes, we will follow Carpenter’s [1992] convention of inverting the type hierarchy, but still calling the more specific types ‘subtypes.’

²In particular, we refer to a near-ALE-compatible port of an October, 1999 version of the ERG generated from the CSLI test suite using scripts written for this purpose by Ann Copestake. We are indebted to her for making the grammar, test suite and scripts available to us.

Sag [1994] and earlier for reasoning about lists. Finite domains were available in Erbach's ProFIT system [Erbach, 1995] and the Smyth powerdomain construction has been identified as highly relevant to signature representations of feature neutrality and coordination [Levy and Pollard, 2002]. To our knowledge, however, the closest any grammar development environment (GDE) has come to realizing these is ProFIT, and even then only as finite domains and a limited form of parametric typing without the conventions necessary (in our view) to encourage their use on a large scale. In addition, our proposal for default specification bears some similarity to Koenig and Jurafsky's [1994] proposal of "on-line type construction," and to the treatment of intersection types in the TDL system [Krieger and Schaefer, 1994].

The payoff, ultimately, will naturally include more readable and transparent grammar signatures, but also the potential to automate certain portions of the grammar development process, to increase the inferential capacity of GDEs, and thus to assist developers in understanding the grammars they build. With a few superficial exceptions, that capacity is currently limited to automatically computing the unification algebra implied by the signature. Feature structure unification is a by-product of the primitives IS-A and HAS-A (feature appropriateness), and this limitation is due to the conventional restriction of using only these two primitives in signature development.

2 The case against IS-A

As external observers examining the ERG signature after its completion, our primary sources of evidence that IS-A is not sufficient are the naming conventions applied to types and the regular or near-regular correspondences which are apparent relative to the IS-A relationships posited between those types. These sources are corroborated by discussions in the linguistics literature (as early as Pollard and Sag [1994]) of the intended significance of various types and alternative formulations. To this extent, IS-A networks have adequately conveyed to us the intentions behind the types employed, but at a cost, both in terms of the time required, and in terms of our inability to automatically deduce many of these regularities.

As a result of this study, we can cite three specific shortcomings evident in the exclusive use of IS-A in the ERG, as enumerated in the subsections below.

2.1 Lack of a uniform semantics

Problems with semantic uniformity should be readily apparent to those who have attempted to construct object models in programming languages using subsumption hierarchies. The problem centers around the difficulty of expressing relationships other than inclusion. Object-oriented programming languages differ in the remedies they provide, such as user-defined methods, *ad hoc* overloading or inheritance-based polymorphism in C++, and interface implementation in Java.

In an orthodox view of both typing and HPSG, the only remedies provided in

the context of grammar development exist outside the type system itself, such as feature values with appropriateness and description-level structure sharing. A less orthodox view, both linguistically and relative to the role of typing in programming languages, suggests that types and description-level functions or relations are in fact equivalent (an instance of the so-called *Curry-Howard isomorphism*), and thus that Prolog-style relations can also mediate communication between modules, namely through their arguments. Such relations, as operationally distinct constructs, are not productively used in the ERG, and in HPSG its mention generally evokes the expectation of very costly run-time proof searches.³ Against the backdrop of such a prejudice, higher-order typing constructors are, to our knowledge, the only available formal alternative. The use of relations will not be explored further here, but it is important to note the availability and relatedness of this option.

In the HPSG linguistics literature, on the other hand, one instead often finds a resort to informal typographical conventions that also exist outside the type system. As a very influential example on the ERG, we may consider Sag's [1997] treatment of relative clauses (Figure 1). This paper analyzes relative clauses along two separate dimensions: clausality and headedness. In other words, every subtype of *phrase* must make some claim regarding whether or not it is a clause and whether or not it has a head. The capitalization and framing of CLAUSALITY implicitly indicates that this is not a kind of phrase but a dimension of phrasal classification.

The problem with such a convention is that within the formal type system itself, there is still no multi-dimensionality. The link from *phrase* to CLAUSALITY, for example, simply looks like any other IS-A link. In addition, if CLAUSALITY and HEADEDNESS are indeed different dimensions, they should not have common subtypes such as *wh-subj-rel-cl*. That this particular join is not an ordinary upper bound but in fact a subtype of phrase that reifies a particular choice of CLAUSALITY and HEADEDNESS is not indicated with even a typographical convention.

2.2 Erosion of dimensionality

The ERG, to its credit, has eliminated the types CLAUSALITY and HEADEDNESS, but has retained the essential problem with the above analysis. In addition, these types have been replaced by types called *clause* and *headed-phrase*, which are two among the many immediate subtypes of *phrasal*, a subtype of *phrase* (Figure 2). In doing so, it is simply less apparent that phrases can be analyzed along these two independent dimensions.

Parametric typing, the use of functions that map products of types to types, circumvents this problem by allowing us to explicitly identify each of the top row of intersection types by the combination of properties it represents, e.g., *phrase(wh-*

³In HPSG's type system, these searches actually have a parallel in the requisite task of maximal sort resolution. This is NP-complete [Penn, 2001], and as a result, many grammars, including the ERG, have been developed with an alternative view of subtyping in mind in which this resolution is never performed.

rel-cl, *hd-subj-ph*) rather than *wh-subj-rel-cl*, and define the type signature without having to explicitly enumerate all of the possible combinations. The parameters of parametric types cannot be “structure-shared” because they are only types, not feature structures, so the potentially non-modular effects of structure-sharing are still absent.

2.3 Inconsistent naming conventions

Most HPSG linguists probably realize what a *wh-subj-rel-cl* is, and the name itself does suggest that this phrasal type is a *rel-cl* and a *hd-subj-ph* (although headedness itself is not indicated), but there are other cases in the ERG where the naming conventions are far less transparent. For example:

- Order is sometimes used rather than an additional compound name. The difference between a *head-adj-ph* and a *adj-head-ph*, for example, is that the former is both *head-initial* and a *head-mod-phrase-simple*, while the latter is *head-final* and a *head-mod-phrase-simple*.
- Some would-be parameters actually appear in their negated forms, such as the subtypes, *nonque*, *nonrel* and *nonslash*, of *word*. Presumably, this choice of polarity serves to reduce the number of intersection types that would otherwise need to have been explicitly defined.
- The type *non1sg* does not actually refer to all non-first-singular person-number combinations, but only to those that are also non-third-singular. To know this, we must observe that *non1sg* is actually a subtype of *non3g* in the ERG. The name presupposes an acquaintance with English verbal inflectional patterns.
- Several different kinds of connectives are employed in names, and, because these names are simply strings, it is not always clear what their scope is. We thought we understood *1or3pl+2per+1per+non1sg*, for example, until we saw that it is a subtype of *1sg*+2per+1per+non1sg*.
- Other connectives are simply not clear in their intended meaning. *basic-cp-prop+ques-verb*, for example, has only one supertype (*verb-synsem*). This is not the same + that denotes intersection elsewhere.

With parametric types, intersection types are implicitly created, and the names of the parametric types themselves serve to better identify their decomposition and purpose. Notice that *pernum*, the base person-number combination, could just as well be *index(person,number)*, *noun(person,number)* or *verb(person,number)*, to indicate what is intended. As for *head-adj-ph* and *adj-head-ph*, there are by our count at least five independent dimensions on which phrases are being classified:

1. initial vs. final,

2. binary vs. unary,
3. headed vs. non-headed,
4. intersective vs. scopal, and
5. 'h' vs. 'n' (we have not determined what these letters stand for).

These are in addition, although not unrelated, to the more familiar distinctions among complement phrases, subject phrases, etc. of HPSG. It took us a day to determine that these were the parameters, but we can now say where an *n-adj-redrel-ph* stands with respect to all of them. Can you?

3 Higher-order constructors for the ERG

3.1 Parametric/Product types

We have already seen a few instances where parametric types seem to be called for. For the most part, we follow Penn [2000] in the formal details of extending type signatures to parametric type signatures. Formally, parametric types are functions that provide access or a means of reference to a set of types (their image) by means of argument types called *parameters* (their domain). In HPSG, the best known example is the unary parametric type, *list*. *list*(α) labels feature-structure-encoded lists in which each member is of type α .

Definition 1. A *parametric (type) hierarchy* is a finite bounded-complete partial order (BCPO), $\langle P, \sqsubseteq_P \rangle$, plus an arity function, $\text{arity} : P \rightarrow \text{Nat} \cup \{0\}$, and a partial argument assignment function, $a_P : P \times P \times \text{Nat} \rightarrow \text{Nat} \cup \{0\}$, in which:

- P consists of (simple and) parametric types, and includes the most general type, \perp , which is simple, i.e., $\text{arity}(\perp) = 0$,
- For $p, q \in P$, $a_P(p, q, i)$, written $a_p^q(i)$, is defined iff $p \sqsubseteq_P q$ and $1 \leq i \leq \text{arity}(p)$,
- $0 \leq a_p^q(i) \leq \text{arity}(q)$, when it exists, and
- if $a_p^q(i) \neq 0$ and $a_p^q(i) = a_p^q(j)$, then $i = j$.

Every parametric type hierarchy, P , is equivalent to a possibly infinite non-parametric IS-A network, $I(P)$:

Definition 2. Given parametric type hierarchy, $\langle P, \sqsubseteq_P, \text{arity}, a \rangle$, the induced (type) hierarchy, $\langle I(P), \sqsubseteq_I \rangle$, is defined such that:

- $I(P) = \bigcup_{n < \omega} I_n$, where the sequence $\{I_n\}_{n < \omega}$ is defined such that:
 - $I_0 = \{p \mid p \in P, \text{arity}(p) = 0\}$,

– $I_{n+1} = I_n \cup \{p(t_1, \dots, t_{arity(p)}) \mid p \in P, t_i \in I_n, 1 \leq i \leq arity(p)\}$,
and

- $p(t_1, \dots, t_{arity(p)}) \sqsubseteq_I q(u_1, \dots, u_{arity(q)})$ iff $p \sqsubseteq_P q$, and, for all $1 \leq i \leq arity(p)$, either $a_p^q(i) = 0$ or $t_i \sqsubseteq_I u_{a_p^q(i)}$.

Subtyping in $I(P)$ is given by subtyping according to P , and subtyping in every dimension according to $I(P)$.

A parametric type signature consists of a parametric type hierarchy together with a feature appropriateness specification:

$$Approp_P : Feat_P \times P \longrightarrow (I(P) \longrightarrow I(P)),$$

in which the value restrictions can make reference to the parameters of the type that bears their features. Penn [2000] also defines the structural restrictions on parametric type hierarchies and appropriateness specifications, called *semi-coherence*, *persistence* and *parametric determination*, that ensure that the equivalent non-parametric signature is a BCPO.

In practice, parametric type signatures can be defined using an adjacency representation of a cover relation and type variables that take scope over these and the value restrictions of any attached appropriateness specifications. For example, in ALE-like notation, parametric lists can be defined by:

```
list(X) sub [e_list(X), ne_list(X)].
ne_list(X) intro [hd:X, tl:list(X)].
```

Here the type variable X ranges over all possible types, including other lists. As alluded to in Penn [2000], however, it is possible to employ *parameter restrictions* to force the equivalent non-parametric BCPO to be finite. In the case of the parametric *index* type referred to above, we can restrict its parameters to the sensible portions of the type hierarchy that deal with *person*, *number*, and *gender*:

```
index(P:person, N:number, G:gender) sub [ref(P, N, G)].
index(3rd, sing, neut) sub [there, it].
```

Here, each parameter restriction declares a *filter*, or upward closed set of types, from which the corresponding parameter must be chosen. The definitions from Penn [2000] are not compatible with the second line of the *index* example above, but can be extended, once parameter restrictions are in place, to allow maximal types in the image of a parametric type to be used on the left-hand-side of a subtyping declaration. Again, the only trick is to define the structural conditions in the original parametric type signature that preserve bounded-completeness in the equivalent non-parametric signature, if that is desired.

In the example above, this extension is necessary because there is only one kind of *index(P, N, G)* that requires further specification, and *there* and *it* cannot be viewed as subtypes of other combinations of *person*, *number* and *gender*, such as

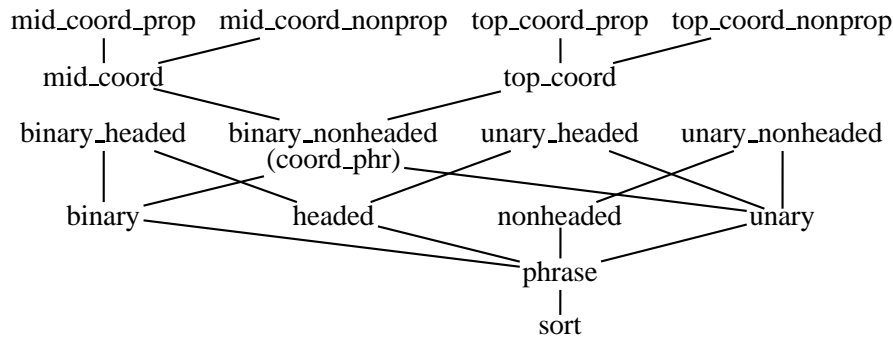

Figure 3: Extension of a filter of parametric types.

index(2nd,plural,masc). In the case of the ERG, we can see this at work within the classification of English phrase types (as simplified in Figure 3). *phrase* is classified along the dimensions of arity and headedness, but only *binary_nonheaded* requires further speciation along the dimensions of *mid* vs. *top*, and *prop*. This can be declared as follows:

```

% boolean dimension
bool sub [+ , -].

% arity dimension
arity sub [binary , unary].

% "semantic height" dimension
semheight sub [mid , top].

% phrase is classified according to arity and headedness
sort sub [phrase(arity:arity,head:bool)].
coord_phr syn phrase(arity:binary,head:-).

% add extra dimensions where necessary
coord_phr adds (sem:semheight,prop:bool).

```

Notice that each dimension or parameter can bear a name, such as *head*, to permit greater reuse of more general filters such as *bool*. Also note that new parameters can simply be added to an existing product where necessary with *adds / 2* without introducing a new parametric type, and that type synonyms like *coord_phr* can be defined for greater readability.

Parametric typing is a very expressive device, especially because parameter variables can take scope over appropriateness specifications. The other constructors presented below, in fact, can be viewed as parametric types for which the correspondence to a non-parametric IS-A network is given by something other than a product.

3.2 Optionality

Several dimensions can be thought of as optional. When they are not present, extra types are used in the ERG to assert this. For example, there is a type *no_head*, and a *no_cl_mode*, and although they do not occur as types on their own, the suffixes, *_no_affix_word*, *_no_quant*, and *_notopkey* are attached to many type names. In the case of *luk*, a supertype of *bool*, it is called *na* (alongside the usual + and -). In the case of *xmod*, absence is signified by *notmod*, and there is even a positive counterpart called *hasmod* (not to be confused with *has_aux*, which refers to the English auxiliary verb, “has”). All of these represent a special kind of linear sum with the standard *bool* type filter. Decomposing *xmod*’s filter as follows:

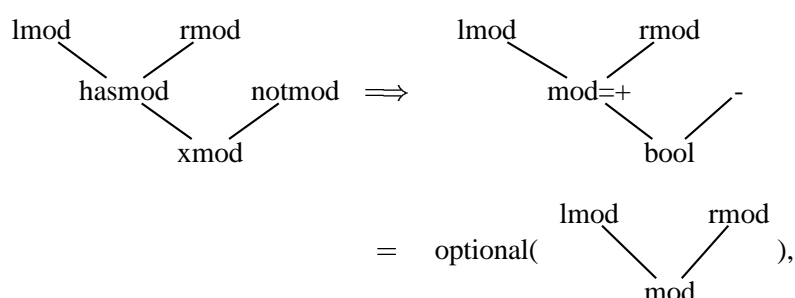

we can view this as an application of the higher-order constructor *optional*, which glues its argument (actually the filter rooted at its argument) to a copy of the *bool* filter. As with parametric types, the *bool* filter still exists in the induced IS-A network, so the following naming convention can be used to refer to the members of the type hierarchy that this constructor induces:

<i>xmod</i>	\mapsto	mod?
<i>notmod</i>	\mapsto	\sim mod
<i>hasmod</i>	\mapsto	mod
<i>lmod</i>	\mapsto	lmod
<i>rmod</i>	\mapsto	rmod.

3.3 Smyth powerdomains

The ERG also defines some types as conjunctions or disjunctions of other types. These types have received a great deal of attention in the literature on coordination in languages with overt case, because they seem to be necessary to capture various generalizations about the coordination of unlike cases (disjunctive), and they establish a symmetry to treatments of feature neutrality in parasitic gap constructions (conjunctive).

We agree with the arguments presented in Levy and Pollard [2002] that these conjunctive and disjunctive types are drawn from the Smyth powerdomain closure of an underlying partial order of basic types (such as cases and their disjunctions). As will be seen below (Section 4), this is not the same as believing that the full

Smyth powerdomain is warranted or even correct in every language, only that some subset of it is. The ERG itself uses only various subsets depending on the basic partial order involved. Where we depart from the ERG is in believing that the (subset of the) Smyth closure must be specified in terms of its basic IS-A links. The Smyth construction can be specified explicitly with a *smyth* constructor that expresses this more straightforwardly.

Simplifying the ERG’s tense filter somewhat, for example, we can fit this constructor to it:

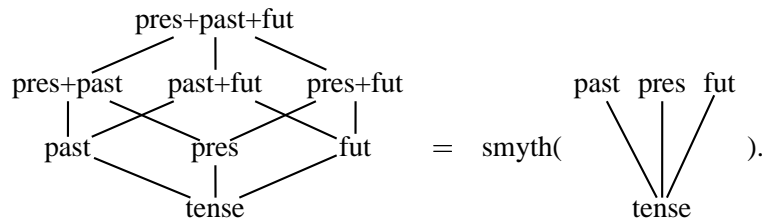

Many other *sort* subtypes in the ERG signature, including, but not limited to, *case*, *gender*, *pernum*, and *mood*, have filters containing disjunctions and conjunctions, suggesting a Smyth powerdomain.

3.4 Purity / Strictness

In the ERG, many types also have a “strict” variant declared as a subtype, e.g., *strict_pernum* as a subtype of *pernum*, *strict_tense*, a subtype of *tense*, etc. Strict variants isolate those subtypes with a more classical or narrowly defined sense within a larger classification. Levine et al. [2001] calls this aspect of types “purity” rather than strictness, and extends it to apply to conjunctive types to account for instances of case neutralization. Daniels [2002] proposes to extend it further to disjunctive types to account for certain coordination data. The following table illustrates the notational variation between these approaches on the one hand and the ERG on the other:

Aspect	Daniels	ERG
purity	'p-' prefix	unmarked or <i>strict_</i> prefix
impurity	unmarked	'-*' suffix
conjunctive	'-' connective	'+' connective (non-minimal)
		'and' connective (minimal)
disjunctive	'+' connective	'or' connective

Strict extensions of type filters in the ERG do differ somewhat in their structure from that of purity in Daniels [2002] (notably, pure types are never subtypes of other pure types), but as Daniels’s [2002] proposal is more systematic in its application of the extension, we shall consider it further in this section rather than the ERG. There is a near one-to-one correspondence between pure and impure variants of types, which can be analyzed into a product between a simpler hierarchy and a

pure-impure filter. Regularizing one of Daniels's [2002] examples by adding a new type to distinguish between impure and pure *nom-acc*.⁴

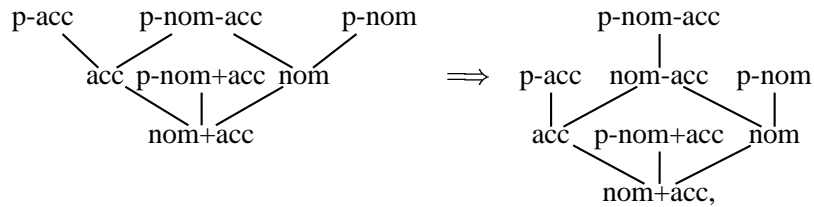

we see that this is contained within:

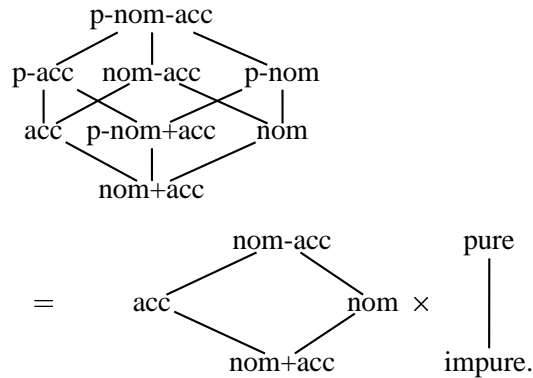

The left-hand-side of this product, however, is simply the Smyth powerdomain of a classic case distinction:

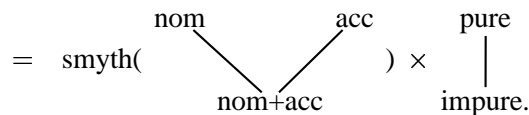

The *purex* constructor builds the necessary portion of this product, in which the IS-A links between pure types are missing:

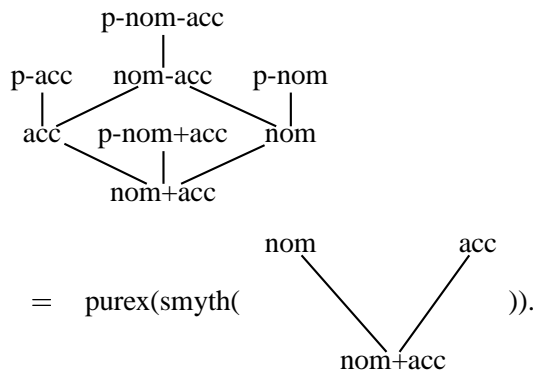

⁴This does not change the meaning of the construction because *p-nom-acc* is the sole maximal extension of *nom-acc*.

Notice the following symmetry: *optional* is a sum with the discretely ordered + and −, whereas *purex* is formed from a product with the totally ordered *impure* and *pure*.

In the ERG, strict variants appear as part of many type declarations, including *tense*, *aspect*, *gender*, *pernum*, and *luk*.

3.5 Finite domains

The ERG also employs finite domains, or powersets of finite sets by enumerating all disjunctive combinations of a discretely ordered set of basic elements. The case example above contains a simple instance of this:

$$\begin{aligned} & \text{purex(smyth(} \begin{array}{cc} \text{nom} & \text{acc} \\ & \diagdown \quad \diagup \\ & \text{nom+acc} \end{array} \text{))} \\ & = \text{purex(smyth(fd(\{nom,acc\})))} \end{aligned}$$

Another example is the ERG’s system of extended boolean types, rooted at *luk*. Systematizing the ERG naming conventions used here and simplifying the filter somewhat, we can see:

$$\begin{array}{c} \begin{array}{ccccc} & - & \text{na} & & + \\ & | & / \quad \backslash & & | \\ \text{na_or_} & - & +_or_ & - & \text{na_or_} \\ & \backslash & | & / & \backslash \\ & \text{na_or_} & -_or_ & + & \\ & & \text{(luk)} & & \end{array} \\ = \text{fd(} \begin{array}{c} - \quad \text{na} \quad + \\ \backslash \quad | \quad / \\ \text{luk} \end{array} \text{).} \end{array}$$

Portions of the *phrase* filter also have finite-domain-like structure.

3.6 Unions of constructors

Some of the examples above are slightly modified from the type hierarchy fragments that actually occur in the ERG. As they actually appear, they can still be thought of as reflexes of higher-order constructors, but only by taking the union of several different ones. Union is the implicit operator that combines the different subtyping declarations in a signature, so this is nothing unusual. In the case of higher-order typing constructors in which the names of individual types are established by convention, however, some additional means is necessary for taking the union of non-disjoint sets of types in order to determine which types are being referred to by multiple names. In the ERG, the unions we have analyzed for which this is necessary all consist of higher-order constructors that apply to identical filters, so this is most easily achieved by thinking of union as a higher-order combination of these constructors. For example, in the case of the pure-impure cases as they appear in Daniels [2002]:

$$\begin{array}{c}
\text{p-acc} \quad \text{nom-acc} \quad \text{p-nom} \\
| \quad \quad | \quad \quad | \\
\text{acc} \quad \text{p-nom+acc} \quad \text{nom} \\
| \quad \quad | \\
\text{nom+acc}
\end{array}$$

$$= \text{smyth} \left(\begin{array}{c} \text{acc} \quad \text{nom} \\ | \quad | \\ \text{nom+acc} \end{array} \right) \cup \text{purex} \left(\begin{array}{c} \text{acc} \quad \text{nom} \\ | \quad | \\ \text{nom+acc} \end{array} \right)$$

$$= (\text{smyth} \cup \text{purex}) \left(\begin{array}{c} \text{acc} \quad \text{nom} \\ | \quad | \\ \text{nom+acc} \end{array} \right).$$

Taking *bool* to be *bool** (because it has subtypes, *+** and *-**) and equivalent to *+_or_-*, and *luk* to be equivalent to *na_or_+or_-*, we can approximate the decomposition of the *luk* filter as it appears in the ERG as follows:

$$\begin{array}{c}
\text{-} \quad \text{+and-} \quad \text{+} \\
| \quad \quad | \quad \quad | \\
\text{-*} \quad \text{na} \quad \text{+*} \\
| \quad \quad | \quad \quad | \\
\text{na_or_-} \quad \text{bool} \quad \text{na_or_+} \\
| \quad \quad | \\
\text{luk}
\end{array}$$

$$\subset \text{smyth} \left(\begin{array}{c} \text{+} \quad \text{-} \\ | \quad | \\ \text{bool} \end{array} \right) \cup \text{purex} \left(\begin{array}{c} \text{+} \quad \text{-} \\ | \quad | \\ \text{bool} \end{array} \right) \cup \text{fd}(\text{opt} \left(\begin{array}{c} \text{+} \quad \text{-} \\ | \quad | \\ \text{bool} \end{array} \right))$$

$$= (\text{smyth} \cup \text{purex} \cup (\text{fd} \circ \text{opt})) \left(\begin{array}{c} \text{+} \quad \text{-} \\ | \quad | \\ \text{bool} \end{array} \right).$$

This decomposition is only approximate (hence the subset sign, \subset) because there is no pure extension of the *bool* type. In a GDE, only a basis of most general types would need to be provided as arguments, on the assumption that the argument sets are upward-closed:

`luk type union([smyth,purex,fd(opt)],bool).`

The tense hierarchy as it stands in the ERG:

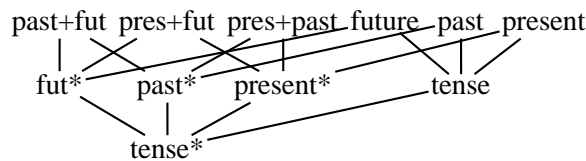

can similarly be approximated:

$$\subset \text{smyth} \left(\begin{array}{c} \text{past} \quad \text{pres} \quad \text{fut} \\ | \quad | \quad | \\ \text{tense} \end{array} \right) \cup \text{purex} \left(\begin{array}{c} \text{past} \quad \text{pres} \quad \text{fut} \\ | \quad | \quad | \\ \text{tense} \end{array} \right)$$

$$= (\text{smyth} \cup \text{purex}) \left(\begin{array}{c} \text{past} \quad \text{pres} \quad \text{fut} \\ | \quad | \quad | \\ \text{tense} \end{array} \right)$$

This, too, is an approximation because there is no type, *pres+past+fut*, in the ERG.

Finally, the xmod hierarchy:

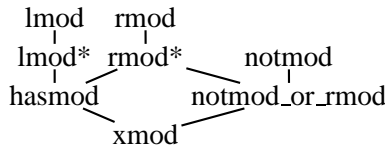

can be approximated, taking *hasmod* to be *lmod_or_rmod* and *xmod* to be *notmod_or_lmod_or_rmod*:

$$\subset \text{fd}(\text{opt}(\begin{array}{c} \text{lmod} \quad \text{rmod} \\ \diagdown \quad \diagup \\ \text{mod} \end{array})) \cup \text{purex}(\begin{array}{c} \text{lmod} \quad \text{rmod} \\ \diagdown \quad \diagup \\ \text{mod} \end{array}).$$

It is an approximation because there is no type, *notmod_or_lmod*, and there is no pure extension of *mod* or *hasmod*.

In the next section, we address the problem of working with these approximations in practice.

4 Default Specifications

Why did the ERG’s designers not use parametric types or these other constructors in the first place? A major reason is that, in many cases, the least upper bounds they were attempting to achieve could only be approximated with them. To reconsider Figure 1, not every combination of CLAUSALITY and HEADEDNESS is licensed in English — the allowable combinations are explicitly and exhaustively enumerated in the intersection types given at the top of the figure, and this enumeration is a major component of this hierarchy’s factual contribution. With parametric types, one defines the entire range of possible products, unless there is some other convention to tell us which combinations to select or exclude.

There are several reasons to prefer higher-order constructors with such a convention over simply using IS-A networks to enumerate the possibilities. First, we would argue that it is often a better indication of the developers’ perspective on grammar design to use higher-order constructors to define a “smoother,” more regular landscape of possibilities from which those admitted by the grammar can be selected. This is analogous to the benefit that accrues to constraint-based grammars by using signatures to create a more general canvas of possible typed feature structures from which principles of grammar select the ones licensed by the theory. Second, the higher-order declarations make the subtyping definitions more terse and structurally richer, which is then easier for others to navigate through. Third, semi-lattice completion types and other structurally necessary closure types can draw upon this more regular landscape to select their own names. The semi-lattice completion types in the ERG are currently named with “glbtype” plus a number. Fourth, it is possible in principle to use this larger range of types to define a set of possibilities from which a statistical method could select those that are appropriate to a particular corpus or other large domain with more reliability than human grammar designers are capable of.⁵

⁵We are indebted to Rob Malouf for this suggestion during the conference. He also reports that some intersection types that were excluded from the ERG have since been discovered within corpora.

There are several possible conventions that we can imagine using in combination with higher-order typing. All of them use a combination of three devices:

1. Explicit declarations that accompany the signature declaration (such as types to include or exclude),
2. *Generators*, seed sets of included types that are implicitly inferred from their presence in other constructs of the grammar (principles, phrase-structure rules, lexicon, etc.), and
3. Closure under certain structural operations in the signature. Possible operations include:
 - (a) joins: if two types are included, so should their least upper bound be,
 - (b) supertyping: if a type is included, so should all of the more general types that it extends,
 - (c) subtyping: if a type is included, so should all of its more specific extensions,
 - (d) appropriateness: if a type is included, so should all of the types that have appropriate features with that type as a value restriction,
 - (e) value restriction: if a type is included, so should all of the value restrictions that its appropriate features bear.

Again, this is not intended as a closed class of possibilities. It may also be the case that different closures or conventions are used with different sets of types, according to which constructors were used to declare them, or according to where they appear in the grammar. For example, types that appear in a construct other than a lexical item or lexical rule may be closed under joins. No matter what the choice, the equivalent induced IS-A network can be calculated off-line, and thus at no run-time computational cost.

Which conventions are appropriate is naturally an empirical question, and given that only a single grammar has been the object of our study to date, it is one that remains to be answered. In the ERG, at least, what we observe is that closure under supertyping is generally appropriate for types found in lexical rules and the *phrase* filter, and in the case of pure/strict constructions, this is augmented with closure under joins. *strict_2per*, for example, never appears in the grammar apart from its declaration in the signature. But parsing the sentence, “you jump,” requires the existence of this type, as the least upper bound of *strict_non3sg*, the PN value of the lexical entry for “jump,” and *2per*, the PN value of the entry for “you.” We assume that filters would play a significant role not only in serving as the arguments of constructors, as in the previous section, but in defining the scope of these conventions.

5 Conclusion

This paper provided an argument for using higher-order type constructors within grammar development, drawn largely from examples in the ERG signature. Of the 1503 ERG types that we have manually inspected and classified so far, 894 have been semi-lattice completion types, 234 have been substitutes for parametric types, 60 have been auxiliary types to enforce strictness (such as those suffixed with '-*'), 34 have been disjunctive closures of other types present (such as could be achieved with finite domains), and 16 have been conjunctive (such as could be achieved with Smyth closure). That means that approximately 56.5% of the non-completion types could be replaced by a certainly much smaller collection of higher-order constructions with a default specification convention. An additional 195 were lexical semantic relations, over which other higher-order constructors may possibly exist. This remains a very tantalizing area of further exploration.

References

- H. Ait-Kaci. *A lattice theoretic approach to computation based on a calculus of partially ordered type structures*. PhD thesis, University of Pennsylvania, 1984.
- R. Brachman. What's in a concept: structural foundations for semantic networks. *International Journal of Man-Machine Studies*, 9(1):127–152, 1977.
- B. Carpenter. *The Logic of Typed Feature Structures*. Cambridge University Press, 1992.
- M. W. Daniels. On a type-bases analysis of feature neutrality and the coordination of unlikes. In L. Hellan F. van Eynde and D. Beermann, editors, *Proceedings of the 8th International HPSG Conference*. CSLI Publications, 2002.
- G. Erbach. Multi-dimensional inheritance. In *Proceedings of KONVENS-94*, 1994.
- G. Erbach. ProFIT: Prolog with features, inheritance and templates. In *Proceedings of EACL-95*, 1995.
- D. Flickinger. On building a more efficient grammar by exploiting types. *Natural Language Engineering*, 6(1):15–28, 2000.
- J.P. Koenig and D. Jufrasky. Type underspecification and on-line type construction in the lexicon. In *Proceedings of WCCFL-94*, 1994.
- H.U. Krieger and U. Schaefer. TDL - a type description language for constraint-based grammars. In *Proceedings of COLING-94*, pages 893–899, 1994.
- R. Levine, T. Hukari, and M. Calcagno. Parasitic gaps in English: Some overlooked cases and their theoretical implications. In P. Culicover and P. Postal, editors, *Parasitic Gaps*, pages 181–222. MIT Press, Cambridge, MA, 2001.

- R. Levy and C. Pollard. Coordination and neutralization in HPSG. In L. Hellan F. van Eynde and D. Beermann, editors, *Proceedings of the 8th International HPSG Conference*. CSLI Publications, 2002.
- G. Penn. Parametric types for typed attribute-value logic. In *Proceedings of 36th Annual Meeting of the Association for Computational Linguistics and the 17th International conference on Computational Linguistics*, 1998.
- G. Penn. *The Algebraic Structure of Attributed Type Signatures*. PhD thesis, Carnegie Mellon University, 2000.
- G. Penn. Tractability and structural closures in attribute logic type signatures. In *Proceedings of the 39th Annual Meeting of the Association for Computational Linguistics*, pages 410–417, 2001.
- C. Pollard and I. A. Sag. *Head Driven Phrase Structure Grammar*. The University of Chicago Press, 1994.
- I. A. Sag. English relative clause constructions. *Journal of Linguistics*, 33(2): 431–483, 1997.

Clarifying noun phrase semantics in HPSG

Matthew Purver 

King's College London

Jonathan Ginzburg 

King's College London

Proceedings of the 10th International Conference on
Head-Driven Phrase Structure Grammar

Michigan State University

Stefan Müller (Editor)

2003

Stanford, CA: CSLI Publications

pages 338–358

Purver, Matthew & Jonathan Ginzburg. 2003. Clarifying noun phrase semantics in HPSG. In Stefan Müller (ed.), *Proceedings of the 10th International Conference on Head-Driven Phrase Structure Grammar, Michigan State University*, 338–358. Stanford, CA: CSLI Publications. DOI: 10.21248/hpsg.2003.19. 

Abstract

This paper examines reprise questions: questions which request clarification of the meaning intended by a speaker when uttering a word or phrase.¹ As such they can act as semantic probes, providing information about what meaning can be associated with word and phrase types. We present corpus evidence regarding the meaning of nouns and noun phrases, and argue that this evidence runs contrary to the usual treatments of semantics in HPSG, and to the traditional generalised quantifier view of NPs as sets of sets. Instead we outline an analysis of NPs as (possibly functional) sets of individuals.

1 Introduction

Reprise questions allow a conversational participant (CP) to request clarification of some property of an utterance (or part thereof). In this paper we are concerned specifically with those reprise questions which concern the *meaning* intended by a speaker when uttering a word or phrase. By virtue of this, they can provide information about what meaning can be associated with word and phrase types. This paper discusses the evidence provided by reprise questions regarding the semantics of common nouns (CNs) and quantified noun phrases (QNPs), and outlines some general implications for NP semantics, together with some implications for semantic representation and inheritance in HPSG.

Our central claim is that reprise questions show that CNs denote properties, and QNPs denote (possibly functional) individuals, or sets of individuals. This runs contrary to common HPSG approaches where semantic content is inherited from heads or amalgamated across daughters. It also does not fit with the representation as generalised quantifiers (GQs) commonly assumed by semanticists. Instead we develop a witness-set-based analysis which treats all QNPs in a coherent manner, and allows a suitable analysis of reprise questions. We then briefly discuss some issues which arise from this, such as anaphora, quantifier scope and the representation of non-monotone-increasing NPs.

1.1 Corpus Evidence

As reprise questions manifest themselves in distinctive ways (e.g. sequences of words repeated from the immediately preceding turn), they are relatively easy to find in a corpus, and it is usually clear which word or phrase they are intending to clarify. We could therefore use the British National Corpus (BNC) (see Burnard, 2000) and the search engine SCoRE (see Purver, 2001) to provide actual occurrences of reprise questions in dialogue. By examining the examples in their surrounding context (including the responses of other CPs) we could then construct possible (and impossible) paraphrases of the meaning of the questions,

¹The authors are supported by the UK Engineering and Physical Sciences Research Council under grant GR/R04942/01. They would also like to thank the anonymous reviewers, Bill Ladusaw, Gerald Penn, John Beavers and Christian Ebert for useful discussion and comments.

and therefore the intended meaning of the original word or phrase. This method is necessarily subjective, but a similar exercise attributing meaning types to clarification questions in this way has been shown to have reasonable statistical reliability when the judgements of two independent markers were compared (see Purver et al., 2001).

1.2 HPSG Notation

Our analysis assumes the (Ginzburg and Sag, 2000) version of HPSG. In order to save space and improve readability, we will use some abbreviations throughout, as shown in table 1.

AVM	Abbreviation
$\left[\begin{array}{l} \textit{parameter} \\ \text{INDEX } x \\ \text{RESTR } \left\{ \left[\begin{array}{l} \text{INSTANCE } x \\ \text{PROPERTY } P \end{array} \right] \right\} \end{array} \right]$	$x : \textit{property}(x, P)$
$\left[\begin{array}{l} \textit{proposition} \\ \text{SOA NUCLEUS } \left[\begin{array}{l} \textit{verb_rel} \\ \text{ROLE_1 } x \\ \text{ROLE_2 } y \end{array} \right] \end{array} \right]$	$\textit{verb}(x, y)$
$\left[\begin{array}{l} \textit{question} \\ \text{PARAMS } \{ \} \\ \text{PROP } \textit{verb}(x, y) \end{array} \right]$	$? \{ \} . \textit{verb}(x, y)$
$\left[\begin{array}{l} \textit{question} \\ \text{PARAMS } \left\{ x : \textit{property}(x, P) \right\} \\ \text{PROP } \textit{verb}(x, y) \end{array} \right]$	$? \{ x \} . \textit{verb}(x, y)$ or $? \{ x : \textit{property}(x, P) \} . \textit{verb}(x, y)$

Table 1: HPSG AVM Abbreviations

In the next section we give some background on the analysis of reprise questions, and on various views of NP semantics. The subsequent sections 3 and 4 discuss the content of reprise questions for CNs and QNPs together with a corresponding semantic analysis, and some further issues arising from this are discussed in section 5.

2 Background

2.1 Reprise Questions

Ginzburg and Cooper (2001, forthcoming) (hereafter G&C) provide an analysis of proper name (PN) reprise questions which treats them as questions concerning the semantic content of the PN (taken to be a referential index). In this way, a reprise such as that in example (1) can be taken to be paraphrasable as shown, where the two readings are distinct, but both concern the content of the PN *Bo*:

- (1) $\left\{ \begin{array}{l} \text{A: Did } Bo \text{ leave?} \\ \text{B: } \mathbf{BO?} \\ \rightsquigarrow \text{ “Is it } \mathbf{BO}_i \text{ that you are asking whether } i \text{ left?”} \\ \rightsquigarrow \text{ “Who do you mean by ‘Bo’?”} \end{array} \right.$

They analyse this via a representation which expresses contextual dependence: contextually dependent phrases such as PNs denote parameters which are abstracted to a set which is the value of a new C-PARAMS feature. This allows the sign to be viewed as a λ -abstract, or a *meaning* in the Montagovian sense (a function from context to content). This is shown in AVM (2) for A’s original utterance in example (1)²:

- (2) $\left[\begin{array}{l} \text{C-PARAMS } \{x : \textit{named}(x, Bo), a : \textit{speaker}(a), b : \textit{addressee}(b)\} \\ \text{CONTENT } [\textit{ask}(a, b, \{?\}\}.leave(x)] \end{array} \right]$

An equivalent λ -abstract expression (ignoring the parameters associated with speaker and addressee, as we will do from now on for readability’s sake) would be:

- (3) $\lambda\{x : \textit{named}(x, Bo)\}.\textit{ask}(a, b, \{?\}\}.leave(x)$

The grounding process for an addressee now involves establishing the referents of these parameters in context, in order to obtain the fully specified intended content. It is failure to do this that results in the formation of a clarification question with the purpose of querying the sub-utterance associated with a troublesome parameter.

Clausal vs. Constituent Readings They give two possible readings for elliptical questions like “*Bo?*”: a *clausal* question, used to check that the hearer has instantiated the parameter in the correct way (made the correct link to the context), which corresponds to the first yes/no-question paraphrase given in example (1) above, and a *constituent* question used when the hearer cannot instantiate the parameter at all, the second *wh*-question paraphrase.

While the clausal and constituent readings are distinct, they both involve *querying the semantic content* of the relevant sub-utterance, following an inability to find

²Note also that the semantic representation includes the conversational move type *ask*, following Ginzburg et al. (2003) – this is important in order to give the correct interpretation for *clausal* questions (see below).

a suitable referent for that content in the hearer’s context. This allows us to use them to investigate what semantic content can be attributed to various word and phrase types.³

G&C’s analysis applies only to PNs. It is clear that other word and phrase types can be reprised, but it is also likely that not all reprises involve querying a simple referential index. On the other hand, it seems uncontroversial to propose that these questions must query the semantic content of the fragment being reprised (or at least some part of it), and we take this as our basic hypothesis when examining NPs in this paper. Note that we do mean directly conveyed semantic content: reprise questions do not appear to be able to query, say, implicatures or other pragmatically inferred material (see Ginzburg et al., 2003).

2.2 NP Semantics

Common Nouns The semantic content of CNs is traditionally viewed as being a property (of individuals). Montague (1974) expressed this as a λ -abstract, a function from individuals to truth values (e.g. $\lambda x.dog(x)$), and this view is essentially shared by most strands of formal semantics. Variations (especially in representation) certainly exist: in situation semantics this might be expressed as a λ -abstracted infon (Cooper, 1995), in DRT as a predicative DRS (Asher, 1993), but these approaches share the basic view that CNs are properties of individuals.

Quantificational vs. Referential In contrast, the semantic representation of QNPs has long been a subject of lively debate. Traditional views of NP semantics can broadly be described as falling into two camps: the quantificational and the referential. The quantificational view, typified by Russell (1905) and Montague (1974), holds that QNPs contribute quantificational terms to the semantic representation of a sentence. This is exemplified by Barwise and Cooper (1981)’s GQ representation, in which sentences containing QNPs are given representations as follows:

$$(4) \text{ “every } A \text{”} \mapsto \text{every}(A) \quad \text{where} \quad \llbracket \text{every}(A) \rrbracket = \{X | A \subseteq X\}$$

$$(5) \text{ “every } A \text{ Bs”} \mapsto \text{every}(A)(B) \quad \text{where} \quad \llbracket \text{every}(A)(B) \rrbracket = B \in \llbracket \text{every}(A) \rrbracket$$

On this view, QNPs therefore denote families of sets (sets of sets, here the set of those sets which contain A).

In contrast, the referential view (going back to Strawson (1950) and Donnellan (1966)) sees some NPs as directly referential; particularly definites, but sometimes

³As G&C point out, reprise questions may have other possible readings apart from the two described above. In particular, a *lexical* reading concerning phonology or orthography of the words used by the speaker seems to be available in many situations. While seemingly common, we are not concerned with such readings in this paper as they do not shed any light on semantics. When we refer to reprise questions hereafter, this should be taken as referring to semantic content readings only.

also others such as specific uses of indefinites (e.g. Fodor and Sag, 1982).

Strict adherents to the quantificational view take it also to hold for definite descriptions: definites are not considered to be directly referential in the same sense as PNs, but are seen as defined by existential quantification with a uniqueness constraint, with any apparently referential nature argued to follow from pragmatic principles rather than any true semantic reference (see Kripke, 1977; Ludlow and Segal, forthcoming).

Other approaches such as the dynamic theories of Heim (1982) and Kamp and Reyle (1993) might be said to fall somewhere in between the two camps, with definites having some kind of reference (although this may be to a contextual discourse referent rather than a real-world object). In most views, however, NPs with other quantifiers (*every*, *most* etc.) are seen as quantificational.

2.3 HPSG Approaches to Semantics

Inheritance-Based One common framework for representing and constructing semantics in HPSG is the unification/inheritance-based method typified by e.g. (Sag and Wasow, 1999; Ginzburg and Sag, 2000). By default, CONTENT is inherited by mothers directly from head daughters: for QNPs, where the CN is usually treated as the head⁴, this leads to a representation where the content of the QNP is identified with that of the head CN. This content is usually taken to be a parameter with a referential index, although this may be quantified over depending on the nature of the determiner.

$$(6) \left[\begin{array}{l} np \\ \text{PHON} \langle \text{the, dog} \rangle \\ \text{CONT} \boxed{1} \\ \text{DTRS} \left\langle \left[\begin{array}{l} det \\ \text{PHON} \langle \text{the} \rangle \\ \text{CONT} [\textit{quantifier}] \end{array} \right], \left[\begin{array}{l} noun \\ \text{PHON} \langle \text{dog} \rangle \\ \text{CONT} \boxed{1} [x : \textit{dog}(x)] \end{array} \right] \right\rangle \end{array} \right]$$

Amalgamation-Based Another approach commonly used by wide-coverage grammars is Minimal Recursion Semantics (MRS, see Copestake et al., 1999). Here CONTENT is (by default) amalgamated across daughters rather than being inherited directly from the head. Content is represented as *elementary predications*, pieces of propositional information. As can be seen below, this results in a representation of NPs wherein the NP content contains all contributions of its daughters,

⁴Although there are alternative views: see (Beavers, this volume) for a discussion.

including but not limited to the CN:

$$(7) \left[\begin{array}{l} np \\ \text{PHON} \langle \text{the, dog} \rangle \\ \text{CONT} \left[\begin{array}{l} \text{HOOK | INDEX } x \\ \text{RELS } \left\{ \boxed{2} [h0 : the(x, h1, h2)], \boxed{1} [h1 : dog(x)] \right\} \end{array} \right] \\ \text{DTRS} \left\langle \left[\begin{array}{l} det \\ \text{PHON} \langle \text{the} \rangle \\ \text{CONT} \left[\begin{array}{l} \text{HOOK | INDEX } x \\ \text{RELS } \left\{ \boxed{2} \right\} \end{array} \right] \end{array} \right], \left[\begin{array}{l} noun \\ \text{PHON} \langle \text{dog} \rangle \\ \text{CONT} \left[\begin{array}{l} \text{HOOK | INDEX } x \\ \text{RELS } \left\{ \boxed{1} \right\} \end{array} \right] \end{array} \right] \right\rangle \end{array} \right]$$

In the next section we examine CN reprise questions, and show that their meaning seems entirely consistent with the traditional view of CNs as denoting properties, but somewhat at odds with the HPSG approaches shown above. In section 4 we then discuss QNP reprise questions, show that their meaning disposes one towards the referential view of QNP semantics, and propose an HPSG analysis which accounts for CNs and QNPs. Section 5 then discusses some issues raised by the view put forward in section 4.

3 Common Nouns

The traditional view of CNs leads us to expect CN reprise questions to be able to query the property expressed by the noun, and this property only.⁵ The clausal and constituent readings may both still be available, but the property should always be the element under question:

Clausal: “*Is it the property P that you are asking/asserting $X(P)$?*”

Constituent: “*What is the property P which you intend to convey by the word N ?*”

In contrast, it should not be possible for CN-only reprises to be interpreted as questions about e.g. individual referents.

3.1 Corpus Evidence

Indeed, this appears to be the case: all corpus examples of CN reprises found confirmed this expectation. Examples are given here together with what appear to

⁵Note that we are setting mass nouns and bare plurals aside for the present, although we plan to investigate them in the same way in future.

be possible and impossible paraphrases – see example (8)⁶:

- (8) Monica: You pikey! Typical!
Andy: **Pikey?**
Nick: Pikey!
Andy: What's pikey? What does pikey mean?
Monica: I dunno. Crusty.
- ~> "Are you saying I am a **pikey**?"
~> "What property do you mean by the word 'pikey'?"
~> # "Which pikey are you saying I am?"

The same appears to be true when the CN forms part of an indefinite NP as in example (9)⁷:

- (9) Emma: Got a comb anywhere?
Helena: **Comb?**
Emma: Even if it's one of those <pause> tremmy [sic] pretend combs you get with a Barbie doll, oh this'll do! <pause> Don't know what it is, but it'll do!
- ~> "Is it a **comb** that you are asking if I've got?"
~> # "Which comb are you are asking if I've got?"

And indeed even when the CN is part of a seemingly referential definite NP as in example (10)⁸:

- (10) Carol: We'll get the turkey out of the oven.
Emma: **Turkey?**
Carol: Well it's <pause> it's <pause> er <pause> what's his name? Bernard Matthews' turkey roast.
Emma: Oh it's looks horrible!
- ~> "Are you saying the thing we'll get out is a **turkey**?"
~> "What concept/property do you mean by 'turkey'?"
~> # "Which turkey are you saying we'll get out?"
~> # "Is it this/that turkey you're saying we'll get out?"

Note that paraphrases which concern an intended referent of the NP containing the CN (e.g. the "Which X . . ." paraphrases) do not appear to be available, even when the NP might appear to be referential (see example (10)).

3.2 Analysis

As expected, we therefore suppose that the semantic representation of a CN must consist of a property of individuals (which we shall refer to as a *predicate* to differentiate it from a property-of-properties). An analysis entirely parallel to that of section 2.1 is possible if predicates are regarded as possible cognitive / contextual

⁶BNC file KPR, sentences 218–225. For the benefit of non-UK English speakers, *crusty* is a noun here, usually derogatory, and perhaps best thought of as somewhere between *hippy* and *tramp*.

⁷BNC file KCE, sentences 1513–1516

⁸BNC file KBJ, sentences 131–135. It may help non-UK residents to know that a Bernard Matthews' Turkey Roast is a processed meat product: turkey-like, but not actually a turkey.

referents. The CONTENT of a CN can then be a parameter whose INDEX is a named predicate. This parameter is also made a member of C-PARAMS: the hearer must ground it (by finding the intended (predicate) referent given its name) or make it the subject of a clarification question in case this grounding process fails (e.g. in the case of unknown, ambiguous or just surprising words).

$$(11) \left[\begin{array}{l} \text{PHON} \quad \langle \text{dog} \rangle \\ \text{CONTENT} \quad \boxed{P : \text{name}(P, \text{dog})} \\ \text{C-PARAMS} \quad \{ \boxed{P} \} \end{array} \right]$$

Note however that this does not correspond to the standard HPSG approaches of section 2.3. In the inheritance-based approach, CN CONTENT is a parameter whose INDEX is an individual (to be inherited as the referent of a NP mother). Including this parameter in C-PARAMS, as shown in AVM (12), would not give the correct reading for a clarification question, as this individual would become the referent to be grounded and thus the subject of the question (which we have seen is impossible).

$$(12) \left[\begin{array}{l} \text{CONTENT} \quad \boxed{x : \text{dog}(x)} \\ \text{C-PARAMS} \quad \{ \boxed{x} \} \end{array} \right]$$

Similarly in the MRS approach, CN content consists of an EP which again concerns the individual referent which will be quantified over by the mother NP, and making this content contextually available would allow reprise questions which concern this referent.

These problems could be solved by alternative analyses for both approaches whereby only *part* of the content (the predicate) is abstracted, but these would then beg the question of why only that part is abstracted and available for clarification. This would be especially problematic for the inheritance approach where CN and NP content are identical: as we will see below, the two do not give rise to the same reprise questions.

4 Noun Phrases

The quantificational and referential views of QNP semantics would seem to predict different meanings for QNP reprises, at least for those examples which the latter view holds to be directly referential: referential definites and perhaps specific indefinites.

4.1 Definite NPs

Taking a referential semantic viewpoint, we might therefore expect reprises of definite NPs to concern individual referents, and be paraphrasable as follows:

Clausal: “*Is it the individual X about which you are asking/asserting P(X)?*”

Constituent: “*Which individual X do you intend to refer to by the phrase NP?*”

From a quantificational viewpoint, a paraphrase concerning a set of properties or sets might instead be expected:

Clausal: “*Is it the set of properties that hold of X about which you are asking/asserting ...?*”

Constituent reading: “*Which set of properties do you intend to convey by the phrase NP?*”

Our corpus investigation included many types of definite NP: PNs, pronouns and demonstratives as well as definite descriptions. PNs have already been discussed in section 2.1 above – we examine the others here.

4.1.1 Referential Definites

All reprises of demonstratives and pronouns, and most reprises of definite descriptions (over half of the examples we found) appeared to be directly referential, with both clausal and constituent readings available (see examples (13)⁹ and (14)¹⁰).

- (13) John: Which way’s North, do you know?
Sara: That way.
John: **That way?** Okay.
- ~> “Are you telling me **that way there** is North?”
~> “By ‘that way’ do you mean that way there?”
- (14) John: They would be working on the kidnapper’s instructions, the police?
Sid: **The police?**
John: Aye
Sid: On
Unknowns: <unclear>
Sid: aye the, the senior detectives
- ~> “Is it **the police** who you are saying would be working ...?”
~> “Who do you mean by ‘the police?’”

Reprises using PNs Interestingly, it appears possible to reprise these definites not only by echoing verbatim as in example (13), but also by reprising with a co-referring PN as in examples (15)¹¹ and (16)¹². This gives further weight to the idea that these reprises are genuinely referential (PNs are generally held to be referential

⁹BNC file JP4, sentences 755–758

¹⁰BNC file KCS, sentences 661–665

¹¹BNC file KCE, sentences 4190–4192

¹²BNC file KPY, sentences 1005–1008

even by those who hold to the quantificational view of definite NPs).

- (15) Joanne: It's, how many times did he spew up the stairs?
 Emma: **Julian?** Couple of times.
 ~→ "Is it **Julian**_i that you are asking how many times *i* spewed up the stairs?"
 ~→ "By 'he' do you mean Julian?"
- (16) Unknown: And er they X-rayed me, and took a urine sample, took a blood sample. Er, the doctor
 Unknown: **Chorlton?**
 Unknown: Chorlton, mhm, he examined me, erm, he, he said now they were on about a slide <unclear> on my heart. Mhm, he couldn't find it.
 ~→ "By 'the doctor' do you mean Chorlton?"

Two points are perhaps worth reinforcing: firstly, definite descriptions, pronouns, demonstratives and proper names all seem to make the same kind of referential reprise questions available; secondly, it seems very hard to interpret any of these examples as querying a family of sets rather than an individual referent.

We therefore suppose that the content of definite NPs must at least contain, and perhaps consist entirely of, the intended referent (or for plurals, set of referents), as shown in AVM (17). An analysis of these referent reprise questions would then be available exactly as for PNs in section 2.1 – an identifiable referent for the contextual parameter must be found in context as part of the grounding process.

- (17)
$$\left[\begin{array}{l} \text{PHON} \quad \langle \text{the, dog} \rangle \\ \text{CONTENT} \quad \boxed{1} [x : \text{the_dog}(x)] \\ \text{C-PARAMS} \quad \{ \boxed{1} \} \end{array} \right]$$

4.1.2 Functional Definites

Most other examples of definite description reprises did not seem to be querying an individual referent, but seemed better understood as querying a functional referent or its domain. These examples were mostly *attributive* uses (example (18)¹³): we also expect *de dicto* and *narrow scope* uses, among others, to behave in this way.

- (18) Eddie: I want you <pause> to write the names of these notes up here.
 Anon 1: **The names?**
 Eddie: The names of them.
 Anon 1: Right.
 ~→ "What situation/notes should I interpret 'the names' relative to?"
 ~→ "What are you intending 'the names' to refer to in that situation?"
 ~→ # "Which actual names are you referring to by 'the names'?"

Again, a reading concerning properties of properties or sets of sets does not

¹³BNC file KPB, sentences 418–421

seem plausible. We therefore suppose that such uses are best captured by an analysis as sketched in AVM (19), this being the functional equivalent of the version in AVM (17) above, with its constituent function and domain becoming the members of C-PARAMS:

$$(19) \left[\begin{array}{l} \text{PHON} \quad \langle \text{the, dog} \rangle \\ \text{CONTENT} \quad \left[f(s) : s \in D \wedge s \models \text{the_dog}(f(s)) \right] \\ \text{C-PARAMS} \quad \left\{ [f], [D] \right\} \end{array} \right]$$

Both function f and domain D of the argument s must therefore be found in context, and failure to do so licenses clarification questions concerning either function or domain, or both. Note that the idea of domain identification being required for definite interpretation has precedent (e.g. Poesio (1993)’s view of definite interpretation as anchoring a parameter corresponding to the resource situation), but that on our view this is not *all* that is required.

As shown above, we take the function expressed by attributive uses to be one from resource situations to individuals, following (Barwise and Perry, 1983). Other types such as narrow scope uses might be better accounted for as functional on wide-scoping individuals rather than situations.

4.1.3 Sub-Constituent Readings

The few remaining examples of definite NP reprises seemed to have a predicate reading, identical to that which would be obtained by reprising the CN alone. No intonational information is available in the BNC, but these readings appear to be those that are made more prominent by stressing the CN (see example (20)¹⁴).

- (20) Anon 1: They’d carry the sack on their back?
 George: On the back, the bushel, yes
 Anon 1: **The bushel?**
 George: <unclear>
 Anon 1: <unclear>
 George: The corn.
- ~> “What are you referring to by ‘the bushel’?”
 ~> “What property do you mean by ‘bushel’?”
 ~> “Is it the thing with the property **bushel** that you’re saying . . .”

This does not seem to be restricted to definites: we will see the same readings for all other NPs we examined (see below). We will also see below that it is not restricted to the CN predicate – readings corresponding to the logical relation expressed by the determiner are also possible (again, the reader may find this easier to capture by imagining intonational stress on the determiner). In other words, the readings available for reprises of sub-constituents of the NP are still available when reprising the NP, especially when the relevant sub-constituent is stressed. We

¹⁴BNC file H5H, sentences 254–257

therefore suppose that this reading is in fact a focussed reprise of a daughter rather than the NP as a whole, and we will come back to this below.

4.2 Indefinite NPs

Again, a referential viewpoint might lead us to expect that reprises of indefinites should involve a referent; otherwise we expect a set of sets or property of properties.

4.2.1 Sub-Constituent Readings

However, if they do exist, such readings seem to be uncommon. All singular indefinite examples were most felicitous when read as CN sub-constituent readings (see example (21)¹⁵), as described in section 4.1.3 above. Note that the constituent reading, paraphrased in the examples below as “*What property do you mean by ‘N’?*”, might also be paraphrased “*What is a N?*” – but that this should not be confused with a *referential* constituent reading “*Which N do you mean by ‘a N’?*”.

- | | | |
|------|--|--|
| (21) | | Mum: I've been treating it as a wart. |
| | | Vicky: A wart? |
| | | Mum: A corn and I've been putting corn plasters on it |
| | | ~> “ <i>Is it the property wart_i that you're saying you've been treating it as something with i?</i> ” |
| | | ~> “ <i>What property do you mean by ‘wart’?</i> ” |
| | | ~> # “ <i>Which wart are you saying you've been treating it as?</i> ” |

For plural indefinites the same holds (example (22)¹⁶), although a reading querying the determiner rather than the predicate is also available:

- | | | |
|------|--|--|
| (22) | | Anon 1: It had twenty rooms in it. |
| | | Anon 2: Twenty rooms? |
| | | Anon 1: Yes. |
| | | ~> “ <i>Is it twenty_N that you're saying it had N rooms?</i> ” |
| | | ~> “ <i>Is it rooms that you're saying it had twenty of?</i> ” |
| | | ~> # “ <i>Which twenty rooms are you saying are it had?</i> ” |

Note that again, the set-of-sets reading does not seem at all plausible.

4.2.2 Possible Referential Readings

However, while no clear examples were found in our corpus study, we feel that there *is* a possibility of referential questions with specific indefinites where the hearer realises that the speaker has a particular referent in mind, and intends the hearer to be able to identify it (what Ludlow and Segal (forthcoming) call *definite* indefinites). Some BNC examples, while probably most felicitous when read

¹⁵BNC file KE3, sentences 4679–4681

¹⁶BNC file K6U, sentences 1496–1498

as CN predicate queries, do seem to offer a possible referential paraphrase, e.g. example (23)¹⁷:

- (23) Stefan: Everything work which is contemporary it is decided
 Katherine: Is one man?
 Stefan: No it is a woman
 Katherine: **A woman?**
 Stefan: A director who'll decide.
 Katherine: She's good?
 Stefan: Hm hm very good.
- ~> "Is it a **woman** you are saying it is?"
 ~> ?"Which woman are you saying it is?"

If these readings are possible, an analysis of indefinites should allow for them to be constructed. Given this and the implausibility of a set-of-sets reading, we propose that as for definites, the content of indefinites should be an individual (or set of individuals). In ordinary uses this content must be existentially quantified at sentence/clause level (via STORE) – definite uses are distinguished simply by making the content a member of C-PARAMS (see the two versions in AVM (24)).

- (24)
$$\left[\begin{array}{l} \text{PHON} \quad \langle \text{a, dog} \rangle \\ \text{CONTENT} \quad \boxed{\lambda x : \text{dog}(x)} \\ \text{STORE} \quad \{ \boxed{\lambda} \} \\ \text{C-PARAMS} \quad \{ \} \end{array} \right] \quad \left[\begin{array}{l} \text{PHON} \quad \langle \text{a, dog} \rangle \\ \text{CONTENT} \quad \boxed{\lambda x : \text{dog}(x)} \\ \text{STORE} \quad \{ \} \\ \text{C-PARAMS} \quad \{ \boxed{\lambda} \} \end{array} \right]$$

4.3 Other Quantified NPs

Reprises of QNPs with other quantifiers are very rare in the BNC¹⁸, so we cannot claim strong results; but what examples we could find show similar behaviour to indefinites. Set-of-sets readings seem impossible; most examples seem best interpreted as concerning sub-constituents (either the CN predicate or the logical determiner relation); but referential interpretations seem possible too (see exam-

¹⁷BNC file KCV, sentences 3012–3018

¹⁸This is not surprising, as these NPs are relatively rare in the BNC to begin with: there are more than 50 times more sentences containing “the N” as there are containing “every N”, and “most N”, “many N” and “few N” are even rarer.

ple (25)¹⁹:

- (25) Richard: No I'll commute every day
Anon 6: **Every day?**
Richard: as if, er Saturday and Sunday
Anon 6: And all holidays?
- ~> "Is it **days**_N that you are saying you'll commute every N?"
~> "Is it **every**_D that you are saying you'll commute on D days?"
~> "Which days do you really mean by 'every day'?"

We should perhaps not be surprised by referential readings with universal quantifiers: universals are sometimes considered as definites (see e.g. Abbott, 2001). But although other quantifiers were too rare in the BNC to provide evidence, we can imagine examples in which referential readings seem plausible, especially when using co-referring PNs in the reprise:

- (26) A: Most people came to the party.
B: **Most people?**
A: Well, me, Brenda and Carmen.
- ~> "Who do you mean by 'most people'?"

Given this possibility, we propose to analyse these QNPs like indefinites: as existentially quantified sets of individuals, which are not contributed to C-PARAMS under normal circumstances. Referential uses are obtained simply by adding the content to C-PARAMS.

4.4 HPSG Analysis

QNPs as Witness Sets The evidence therefore leads us towards a representation whereby all QNPs denote sets of individuals, while CNs denote predicates. Referential NPs (including definites and referential uses of indefinites) are those where the set must be identified in context; for non-referential NPs, the set must be existentially quantified.

Such an existentially quantified set representation is justified for all monotone-increasing (MON \uparrow) quantifiers if we take the sets as Barwise and Cooper (1981)'s *witness sets*: they show that a verbal predicate belonging to a GQ $D(A)$ is equivalent to the predicate holding of a witness set, where this is a set w which is both a subset of A and a member of $D(A)$. For an indefinite *a dog*, w can be any nonempty set of dogs; for the universal *every dog*, w is the set of all dogs; for *most dogs*, w is a set containing more than half of all dogs, and so on.

CONTENT Specification Note that under this analysis, NPs do not inherit their content directly from either daughter, or amalgamate it across daughters (the two common HPSG approaches): the referential set reprise reading is available when

¹⁹BNC file KSV, sentences 257–260

reprising NPs, but not when reprising daughters. Instead of using a general inheritance or amalgamation principle, we must therefore posit a type *qnp* for all QNPs which specifies how the semantic representation is built:

$$(27) \left[\begin{array}{l} \text{qnp} \\ \text{CONTENT} \quad [w : w = Q'(P)] \\ \text{DTRS} \quad \left\langle \left[\begin{array}{l} \text{det} \\ \text{CONTENT} \quad Q' \end{array} \right], \left[\begin{array}{l} \text{nominal} \\ \text{CONTENT} \quad P \end{array} \right] \right\rangle \end{array} \right]$$

Here we are representing the CN as a predicate P and the determiner as a logical relation Q' between predicate and witness set. In Barwise and Cooper (1981)'s terms, this can be related to the standard GQ representation $Q(P)$ as follows:

$$(28) \quad w = Q'(P) \quad \leftrightarrow \quad w \subseteq P \wedge w \in Q(P)$$

Note that the constraint expressed above is still monotonic (no semantic information is dropped in construction of the mother) and compositional (the content of the mother is obtained purely by functional application of daughter contents). But note also that by this nature it does not fit with the approaches we are used to in HPSG: content is not simply inherited nor amalgamated.

Existential Quantification and STORE Quantification uses the familiar lexically-based storage and retrieval method of (Ginzburg and Sag, 2000): existentially quantified elements are added to STORE, inherited via heads and retrieved into QUANTS. As only existential quantification is being used, the members of QUANTS can simply be parameters rather than quantifiers, and their order is not important. QUANTS can therefore be a set rather than a list, no longer requiring the `order` operator of Ginzburg and Sag (2000). The members of the QUANTS set are taken to be *simultaneously* quantified over, following Cooper (1993)'s definition of simultaneous quantification for STDRT.

Our version of the STORE Amalgamation Constraint therefore appears as in AVM (29):

$$(29) \left[\begin{array}{l} \text{word} \\ \text{CONTENT} \quad [\text{QUANTS} \quad \boxed{2}] \\ \text{STORE} \quad \{ \boxed{1} \cup \dots \cup \boxed{n} \} - \boxed{2} \\ \text{ARG-ST} \quad \left\langle [\text{STORE} \quad \boxed{1}], \dots, [\text{STORE} \quad \boxed{n}] \right\rangle \end{array} \right]$$

C-PARAMS Amalgamation We have seen that reprising a QNP mother can sometimes give a reading which queries only a focussed sub-constituent daughter; but reprising a daughter cannot query the content of the mother (or indeed its sisters, although we have not shown evidence for this here). Therefore the C-PARAMS value of NPs must include the amalgamated values of its daughters so that they can

form the subject of the query²⁰, but this cannot be inherited directly from any one of them. C-PARAMS must therefore be amalgamated by mothers directly across daughters (rather than via lexical heads and inheritance as assumed by G&C). We can express this as a default constraint:

$$(30) \left[\begin{array}{l} \textit{phrase} \\ \text{C-PARAMS} \quad \boxed{1} \cup \dots \cup \boxed{n} \\ \text{DTRS} \quad \left\langle \left[\text{C-PARAMS} \quad \boxed{1} \right], \dots, \left[\text{C-PARAMS} \quad \boxed{n} \right] \right\rangle \end{array} \right]$$

However, definite NPs must override this default, as they also introduce a new parameter (their own content). Indefinites hold to the default, but we must ensure that their content is instead existentially quantified.

Definiteness Principle So indefinites contribute their content to STORE, while definites contribute it to C-PARAMS. We can therefore state a general Definiteness Principle: the content of a NP must be a member of either C-PARAMS or STORE. For words, this is simply expressed:

$$(31) \left[\begin{array}{l} \textit{word} \\ \text{CONTENT} \quad \boxed{1} \\ \text{STORE} \quad \boxed{2} \\ \text{C-PARAMS} \quad \left\{ \boxed{1} \right\} - \boxed{2} \end{array} \right]$$

For phrases, we must combine with STORE inheritance and C-PARAMS amalgamation (replacing AVM (30)):

$$(32) \left[\begin{array}{l} \textit{phrase} \\ \text{CONTENT} \quad \boxed{1} \\ \text{STORE} \quad \boxed{2} \cup \boxed{3} \\ \text{C-PARAMS} \quad \left(\left\{ \boxed{1} \right\} - \boxed{2} \right) \cup \boxed{4} \cup \dots \cup \boxed{n} \\ \text{HEAD-DTR} \quad \left[\text{STORE} \quad \boxed{3} \right] \\ \text{DTRS} \quad \left\langle \left[\text{C-PARAMS} \quad \boxed{4} \right], \dots, \left[\text{C-PARAMS} \quad \boxed{n} \right] \right\rangle \end{array} \right]$$

Definites and other referential words/phrases²¹ can therefore be specified as having empty STORE values, forcing their content to be a member of C-PARAMS. Indefinites can be specified as contributing to STORE, and thus can make no contribution to C-PARAMS.

4.5 Summary

This section has shown that reprises of definite NPs query a (possibly functional) referent, and surmised that this may also be true for referential uses of other QNPs.

²⁰We analyse this sub-constituent focussing using Engdahl and Vallduví (1996)'s HPSG treatment of information structure, but space precludes a full exposition here.

²¹On our account, this includes CNs, which are referential to a predicate.

Non-referential uses seem to query sub-constituents: questions about GQs or sets of sets are not plausible.

We have therefore proposed a semantic representation of NPs as witness sets rather than GQs, and shown how to express quantification and the alternation between definiteness and indefiniteness. The next section briefly examines some further implications of this representation.

5 Further Issues

Determiners The analysis of section 4.4 assumed that determiners denoted logical relations between predicates and witness sets. Determiner-only reprises should therefore query such relations, but they are rare in the BNC: the only suitable examples found involved numerals (see example (33)²²). For these examples, the query appears to concern the cardinality of the witness set, which does fit quite nicely with the idea of determiners as denoting set relations.

- (33) Marsha: yeah that's it, this, she's got three rottweiler's now and
 Sarah: **three?**
 Marsha: yeah, one died so only got three now <laugh>
 ~→ "Is it **three**_N you are saying she's got N rottweilers?"

For other determiners, we have to rely on our intuition, and on those QNP reprise examples mentioned in section 4 above in which the determiner appears to be stressed, e.g. example (25) above, for which we gave a determiner paraphrase which again seems to query a relation. Of course, we hesitate to make any strong claims based on this limited evidence, but we can say that the determiner reprises we have seen provide no counter-evidence to the analysis of section 4.4.

Anaphora Intersentential anaphora has already been briefly discussed – pronouns appear to behave like referential definites in that their referents must be identified in context, and can be clarified otherwise. However, accounting for *intrasentential* anaphora requires a further step. If pronouns (and anaphoric definites) refer to existentially quantified elements within the same sentence, they can no longer have a C-PARAM associated with them: they do not refer to an element in the external context.

We therefore propose that elements of C-PARAMS can be removed if they can be identified with an element of QUANTS – i.e. a binding mechanism similar in concept to Poesio (1993)'s *parameter anchoring* and van der Sandt (1992)'s *pre-supposition binding*. This is implemented via a new feature B(OUND)-PARAMS: referential parameters can be members of either C-PARAMS or B-PARAMS, but membership of B-PARAMS is limited to those parameters which can be identified with members of QUANTS). This means we must update our definiteness principle

²²BNC file KP2, sentences 295–297

to allow B-PARAMS membership:

$$(34) \left[\begin{array}{l} \textit{word} \\ \text{CONTENT} \quad \boxed{1} \\ \text{STORE} \quad \quad \boxed{2} \\ \text{C-PARAMS} \quad \boxed{3} \\ \text{B-PARAMS} \quad \{ \boxed{1} \} - \boxed{2} - \boxed{3} \end{array} \right]$$

while B-PARAMS discharge is expressed through a similar mechanism to quantifier retrieval:

$$(35) \left[\begin{array}{l} \textit{word} \\ \text{CONTENT} \quad \left[\text{QUANTS} \quad \boxed{Q} \right] \\ \text{B-PARAMS} \quad \{ \boxed{1_b} \cup \dots \cup \boxed{n_b} \} - \textit{subset}(\boxed{Q}) \\ \text{ARG-ST} \quad \left\langle \left[\text{B-PARAMS} \quad \boxed{1_b} \right], \dots, \left[\text{B-PARAMS} \quad \boxed{n_b} \right] \right\rangle \end{array} \right]$$

We ensure that all members of B-PARAMS are thus discharged by specifying top-level sentences (in our grammar, signs of type *root-cl*) as having empty B-PARAMS.

Quantifier Scope The functional representation of section 4.1.2 allows relative scope to be expressed by regarding narrow-scoping NPs as functional on other wider-scoping sets: the alternative readings of “*every dog_d likes a cat_c*” are produced by the alternative views of *a cat* being a simple existentially quantified individual *c*, or one that is functionally dependent on the set of dogs *f(d)* via an existentially quantified function *f*.²³ This follows simply from the anaphora mechanism described above: the narrow-scope reading is produced by identifying the *domain* of the functional *cat* with the existentially quantified set of dogs via B-PARAMS, while the function is existentially quantified via STORE.

Monotone Decreasing Quantifiers A simple witness set representation cannot be sufficient for non-MON \uparrow quantifiers: the sentence “*few men work*” does not only convey the fact that working holds of some set *w* containing few men, but also that it does not hold of any men not in *w*.

One solution might be to appeal to pragmatics: Hobbs (1996) solves the problem by pragmatically strengthening the sentence meaning to the assertion that *w* is the *maximal* set of working men. Another would of course be to regard the content of QNPs as GQs rather than witness sets, but then we cannot explain why sets-of-sets reprise readings seem impossible. A third, which we favour, is to view non-MON \uparrow QNPs as denoting pairs of *reference set* (the men who work) and *complement set* (the men who don’t). We would then expect reprises to be able to query both sets; again, as examples of non-MON \uparrow QNP reprises are rare, we are not sure

²³This is similar to the choice function approach to scope (see e.g. Reinhart, 1997).

yet whether this is the case, but imagined examples are encouraging. Kibble (1997) gives the following example of complement set anaphora:

(36) | BBC News: Not all of the journalists agreed, among them the BBC's John Simpson.

where *them* is construed to refer to those who did *not* agree. An imagined reprise version seems possible to construe as querying the complement set:

(37) | A: Not all of the journalists agreed.
B: **Not all of them?**
A: John Simpson was pretty combative. Paxman didn't like it much either.
~> "Who do you mean *didn't* agree?"

More data is needed, but if plausible this might allow a neat way to explain complement set anaphora in general.

6 Conclusions

In this paper we have introduced the use of reprise questions as probes in order to investigate the semantic content of words and phrases, and examined the evidence provided thereby as regards the content of CNs and NPs. This has led us to a view of CNs as denoting predicates, and all MON \uparrow QNPs as denoting witness sets, with the difference between definite and indefinite uses expressed by contextual identification via C-PARAMS vs. existential quantification via STORE. We have shown how this can take into account relative scope and anaphora, and suggested a solution for non-MON \uparrow quantifiers via a representation as pairs of sets.

Along the way, we have seen that inheritance/amalgamation approaches common in HPSG do not fit with the evidence. This is not intended as a criticism of these approaches, which serve their intended purpose of building high-level sentence semantics extremely well: it is only once we start to look at this low level, at the semantics that individual words and phrases can have on their own, that we need to revise our thinking.

References

- B. Abbott. Definiteness and indefiniteness. In L. Horn and G. Ward, editors, *Handbook of Pragmatics*. Blackwell, 2001. To appear.
- N. Asher. *Reference to Abstract Objects in Discourse*. Kluwer Academic Publishers, 1993.
- J. Barwise and R. Cooper. Generalized quantifiers and natural language. *Linguistics and Philosophy*, 4:159–219, 1981.
- J. Barwise and J. Perry. *Situations and Attitudes*. MIT Press, 1983.
- L. Burnard. *Reference Guide for the British National Corpus (World Edition)*. Oxford University Computing Services, 2000.
- R. Cooper. Towards a general semantic framework. In R. Cooper, editor, *Integrating Semantic Theories*. ILLC/Department of Philosophy, University of Amsterdam, 1993.

- R. Cooper. The role of situations in generalized quantifiers. In S. Lappin, editor, *The Handbook of Contemporary Semantic Theory*. Blackwell, 1995.
- A. Copestake, D. Flickinger, I. A. Sag, and C. Pollard. Minimal recursion semantics: An introduction. Draft, 1999.
- K. Donnellan. Reference and definite descriptions. *Philosophical Review*, 77:281–304, 1966.
- E. Engdahl and E. Vallduví. Information packaging in HPSG. In C. Grover and E. Vallduví, editors, *Studies in HPSG*, pages 1–31. University of Edinburgh, 1996.
- J. Fodor and I. A. Sag. Referential and quantificational indefinites. *Linguistics and Philosophy*, 5:355–398, 1982.
- J. Ginzburg and R. Cooper. Resolving ellipsis in clarification. In *Proceedings of the 39th Meeting of the ACL*, pages 236–243, 2001.
- J. Ginzburg and R. Cooper. Clarification, ellipsis, and the nature of contextual updates. *Linguistics and Philosophy*, forthcoming.
- J. Ginzburg and I. A. Sag. *Interrogative Investigations: the Form, Meaning and Use of English Interrogatives*. CSLI Publications, 2000.
- J. Ginzburg, I. A. Sag, and M. Purver. Integrating conversational move types in the grammar of conversation. In P. Kühnlein, H. Rieser, and H. Zeevat, editors, *Perspectives on Dialogue in the New Millennium*, pages 25–42. John Benjamins, 2003.
- I. Heim. *The Semantics of Definite and Indefinite Noun Phrases*. PhD thesis, University of Massachusetts at Amherst, 1982.
- J. Hobbs. Monotone decreasing quantifiers. In K. van Deemter and S. Peters, editors, *Semantic Ambiguity and Underspecification*, pages 55–76. CSLI Publications, 1996.
- H. Kamp and U. Reyle. *From Discourse To Logic*. Kluwer Academic Publishers, 1993.
- R. Kibble. Complement anaphora and dynamic binding. In *Proceedings of the 7th annual conference on Semantics and Linguistic Theory (SALT VII)*, pages 346–368, 1997.
- S. Kripke. Speaker’s reference and semantic reference. In *Perspectives in the Philosophy of Language*, pages 6–27. University of Minnesota Press, 1977.
- P. Ludlow and G. Segal. On a unitary semantical analysis for definite and indefinite descriptions. In A. Bezuidenhout and M. Reimer, editors, *Descriptions and Beyond: An Interdisciplinary Collection of Essays on Definite and Indefinite Descriptions*. Oxford University Press, forthcoming.
- R. Montague. The proper treatment of quantification in ordinary English. In R. Thomason, editor, *Formal Philosophy: Selected Papers of Richard Montague*, pages 247–270. Yale University Press, 1974.
- M. Poesio. A situation-theoretic formalization of definite description interpretation in plan elaboration dialogues. In P. Aczel, D. Israel, Y. Katagiri, and S. Peters, editors, *Situation Theory and its Applications*, volume 3, pages 339–374. CSLI Publications, 1993.
- M. Purver. SCoRE: A tool for searching the BNC. Technical Report TR-01-07, Department of Computer Science, King’s College London, October 2001.
- M. Purver, J. Ginzburg, and P. Healey. On the means for clarification in dialogue. In *Proceedings of the 2nd ACL SIGdial Workshop on Discourse and Dialogue*, 2001.
- T. Reinhart. Quantifier scope: How labour is divided between QR and choice functions. *Linguistics and Philosophy*, 20:335–397, 1997.
- B. Russell. On denoting. *Mind*, 14:479–493, 1905.
- I. Sag and T. Wasow. *Syntactic Theory: A Formal Introduction*. CSLI Publications, 1999.
- P. Strawson. On referring. *Mind*, 59:320–344, 1950.
- R. van der Sandt. Presupposition projection as anaphora resolution. *Journal of Semantics*, 9:333–377, 1992.

Noun incorporation and rule interaction in the lexicon

Jeffrey T. Runner 

University of Rochester

Raul Aranovich 

University of California Davis

Proceedings of the 10th International Conference on
Head-Driven Phrase Structure Grammar

Michigan State University

Stefan Müller (Editor)

2003

Stanford, CA: CSLI Publications

pages 359–379

Runner, Jeffrey T. & Raul Aranovich. 2003. Noun incorporation and rule interaction in the lexicon. In Stefan Müller (ed.), *Proceedings of the 10th International Conference on Head-Driven Phrase Structure Grammar, Michigan State University*, 359–379. Stanford, CA: CSLI Publications. DOI: 10.21248/hpsg.2003.20.



1. Introduction: Two types of rules

Wasow (1977) argues that linguistic theory should recognize two qualitatively distinct types of rules: lexical and transformational. His primary argument for this came from distinctions between verbal and adjectival passive participles in English, one type of which is illustrated below. The negative prefix *-un* is able to attach to adjectives but not verbs (1a,b). This prefix can also attach to adjectival passive participles (1c), suggesting they too are adjectives; verbal passive participles, however, appear to be verbs rather than adjectives, appearing in positions restricted to verbs (2).

- (1) a. They were an unhappy couple
 b. *We unknow her whereabouts
 c. Her whereabouts may be unknown [adjectival passive participle]
- (2) a. Mary was elected president [verbal passive participle]
 b. *Mary was happy president

Wasow's claim was that the grammar has two ways of deriving passive participles: one lexical, which creates adjectival passives; the other syntactic, deriving verbal passives. Based on the dichotomy observed in the two types of passive participles, as well as several other constructions, Wasow suggested that the two different rule types shared a cluster of properties, as Table 1 illustrates.

Table 1: Properties that distinguish the two rule types

Criteria	Lexical Rules	Transformations
structure-preserving?	yes	not necessarily
change POS?	possibly	not
local?	yes	not necessarily
fed by transformations?	no	possibly
idiosyncratic exceptions?	yes	little

For the purposes of this paper we will focus on one aspect of Wasow's dichotomy, developed especially in Anderson (1977) and Wasow (1981): syntactic rules affect more "superficial" grammatical function properties, while lexical rules affect deeper lexical semantic properties of lexical items. Wasow's analysis for these differences was that the particular characteristics of the rule type is determined by the domain of rule application. That is, since syntactic rules have access only to syntactic/phrasal informa-

tion, it is this information that they manipulate; and since lexical rules have access only to lexical information, that is what they manipulate. In a sense, the “vocabulary” of the domain of rule application constrains the characteristics of the rule. And given the architecture of the grammar Wasow assumed, with the output of the lexicon feeding the syntax, most of the properties of Table 1 are derived.

Since Bresnan (1982), however, lexicalist theories of grammar have replaced syntactic transformations with lexical rules. In the wake of this paradigm shift, it seems, Wasow’s dichotomy is potentially left unexplained: if all rules are lexical, the differences between the properties of the two rule types cannot follow from the differences between the lexicon and the syntax. We believe that Wasow was fundamentally correct in recognizing two qualitatively different types of rules. Our goal in this paper is to recapture Wasow’s insight within a lexicalist framework such as HPSG.

Our proposal builds on Sag & Wasow’s (1999) distinction between *lexeme* and *word*. We claim that there is a contrast between lexical rules that relate lexemes to lexemes (L-to-L rules) and lexical rules that relate words to words (W-to-W rules) and that these differences follow from the architecture of the grammar. In particular, we will argue that syntactic function features (ARGST, VALENCE, etc.) are not defined for lexemes, while lexical semantic features (CONTENT) are. From this it follows that L-to-L rules can affect lexical semantic features, and not syntactic function features. In addition, since words are defined for syntactic function features, W-to-W rules can change them. L-to-L rules are Wasow’s “lexical” rules, and W-to-W rules are his “syntactic” rules.

2. Background and Proposal

Our analysis, which we outline directly below, rests on three basic assumptions within current versions of HPSG. First, following Koenig (1999) and Riehemann (2001), we assume an approach to morphology in which affixes are associated with type schemata that introduce both phonological and SYNSEM information, and subcategorize for a morphological base. In this approach, the “input” to a lexical rule (i.e. the morphological base) is a feature of the output. We will follow Riehemann and call this Type-Based Derivational Morphology (TBDM). To illustrate the approach, Riehemann’s analysis of *-able* adjectives is given in Figure 1. What is important to note here is that the input, labeled MORPH, is a verb with certain CONTENT features, and the entire “output” SYNSEM is an adjective, the phonology of which is made up of the input’s phonology (tagged [1]) plus *-able*.

Second, we follow Sag and Wasow (1999), who suggested that non-phrasal signs are of two different types: lexeme and word. The lexeme car-

ries the information that is shared among all the elements in a paradigm, while all the different “surface” forms in a paradigm are each separate words. For example, the words *love*, *loves*, *loved*, *loving*, *lover*, are all related to a single lexeme *love*.

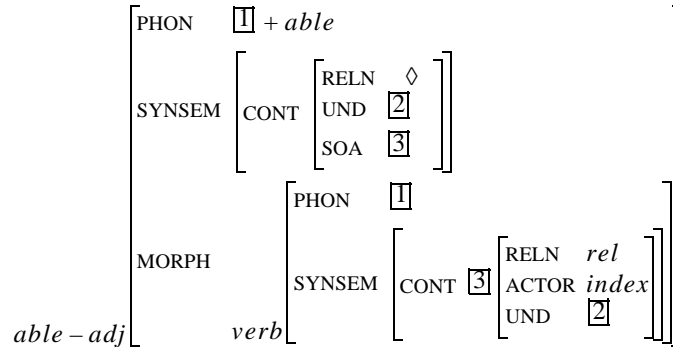

Figure (1): *-able* adjective type in TBDM

Third, we build on work by Davis and Koenig (Davis & Koenig 2000, Koenig & Davis 2001) which claims that the ARGST of a word is predictable from its CONTENT features. In particular, linking constraints are partial specifications of index sharing between members of ARGST and CONTENT; different event types determine different linking constraints. We extend the Davis/Koenig-style linking constraints to relate lexemes and their CONTENT features to words and the appropriate ARGST features in L-to-W types, as illustrated in Figure 2, above. The Actor is linked to the first NP in ARGST. The Undergoer is linked to the last NP in ARGST. What is different here is that the linking constraints are the licensing constraints for L-to-W types. That is, linking constraints need only be obeyed by words that have lexemes as the value of their morphology, not by words that have other words as their input (as in the feature structure for a passivized verb, for instance).¹

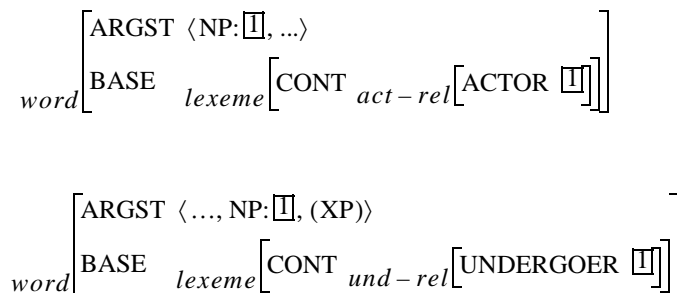

Figure (2): Linking Constraints

We are now ready to outline our proposal, which we call the SPLIT LEXICON HYPOTHESIS. As just mentioned, the Split Lexicon Hypothesis takes as background assumptions the lexeme vs. word distinction, Type-Based Derivational Morphology, and Davis & Koenig-style linking. In addition, we make the following novel claims: (1) lexemes have no ARGST, only words have ARGST; and (2) words are constrained to have the CONTENT features of their base. From the Split Lexicon Hypothesis it follows that L-to-L types (rules) will represent one type of alternation and that W-to-W types represent another. L-to-L types manipulate the lexical semantic features of CONTENT but not the grammatical function features of ARGST; W-to-W types manipulate grammatical function features of ARGST, but not the lexical semantic features of CONTENT.

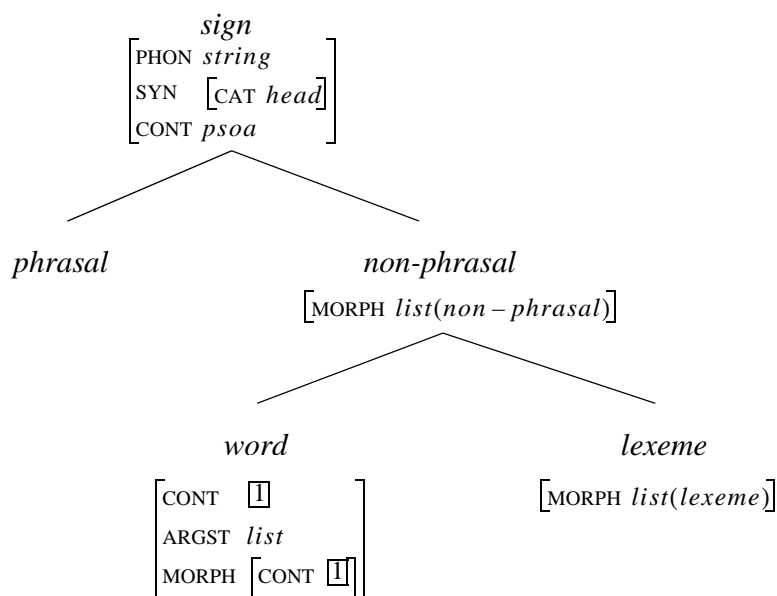

Figure (3): Type Hierarchy

The basic claims of the Split Lexicon Hypothesis are formalized as constraints on the type hierarchy. These are illustrated in Figure 3, above. In addition to the constraints that words but not lexemes have the ARGST feature and that the CONTENT value of the word is the CONTENT value its base, we add the constraint that lexemes have only lexemes as bases. This latter constraint is needed to insure that lexemes are inputs to words, but words are not inputs to lexemes, a constraint any approach assuming the

1. We should point out here that we also differ from Sag & Wasow (1999), who assume verbal inflection is “added” in L-to-W types. We assume, rather, that it is added after all W-to-W types, in an *inflected_word* type.

lexeme/word distinction needs.

The differences between rule types, then, follow in a principled way from constraints on the types of features that are appropriate for each input/output pair. L-to-L types may affect the CONTENT features of a lexical item (but not ARGST). W-to-W types may affect the ARGST features of a lexical item (but not CONT). And, any L-to-L type will be embedded within (will precede) any W-to-W type.

In Aranovich and Runner (2001), we argued that the Split Lexicon Hypothesis accounted for certain differences between the locative alternation and dative shift in English.² In this paper, we will use the Split Lexicon Hypothesis to examine certain differences between two types of Noun Incorporation construction, and their relation to other rules in the grammar. We will argue that Compounding Noun Incorporation is an L-to-L type and that Classifier Noun Incorporation is a W-to-W type; we will base our argument on data from the Paleo-Siberian language Chukchi and the isolate language Ainu. Our argument for the Split Lexicon Hypothesis is based on interaction of Noun Incorporation and Applicative Formation in the two languages.

3. Noun incorporation

In Noun Incorporation (NI), a verb and a dependent noun (normally the direct object) combine to form a complex verb. Several different types of NI have been acknowledged in the literature (Mithun 1984). We focus here on the two types discussed in Rosen (1989): Compounding NI and Classifier NI (see also Gerds 1999 for an overview). Table 2 outlines some of the main differences that have lead researchers to divide these into two types of NI; some of the languages that have been classified as such are listed as well.

Table 2: Two kinds of Noun Incorporation

Compounding NI	Classifier NI
reduces valence	no effect on valence
no doubling	may or may not allow doubling
<u>Chukchi</u> , Polynesian (Samoan, Tongan, Nieuwen), Micronesian (Mokilese, Pohnpeian, Kusaiean)	<u>Ainu</u> , Northern Iroquoian (Mohawk, Seneca, Oneida, Onondaga, Cayuga, Tuscarora), Caddo, Rembarnga, Southern Tiwa, Gunwinggu

2. Driven by somewhat different concerns, Ackerman (1992) and Briscoe & Copestake (1999) also make proposals for two classes of lexical rule types.

Noun Incorporation in Chukchi is of the Compounding type. The main evidence for this is that NI changes the transitivity of the predicate. Chukchi has ergative/absolutive marking, and it shows a complex system of subject/object agreement based on an animacy hierarchy. When the object *mətqəmət* incorporates in (3b), the subject receives absolutive marking, and the agreement marker on the verb (*gʔe*) is the one found in intransitive sentences.

- (3) a. *ətlag-e mətqəmət kawkaw-ək kili-nin* [CHUKCHI]
 father-ERG butter.ABS bread-LOC spread.on-3SG.S/3SG.O
 b. *ətlag-ən kawkaw-ək mətqə=rkele-gʔe*
 father-ABS bread-LOC butter=spread.on-3SG.S
 ‘The father spread butter on the bread.’

Noun Incorporation in Ainu, on the other hand, is of the Classifier type. In this language, NI does not change the transitivity of the predicate. Ainu is also an ergative/absolutive language. When the object incorporates, the agreement marking on the Ainu verb is still ergative (A for Agent), as in (4b) (in one dialect of Ainu, however, the marking changes to absolutive). NI in Ainu does not reduce the verb’s valence, which is typical of Classifier NI languages. Ainu does not allow doubling.

- (4) a. *mukcar-aha a-tuye.* [AINU]
 chest-poss 1s.A-cut
 b. *a-mukcar-tuye.*
 1s.A-chest-cut
 ‘I cut his chest.’

Following Rosen (1989) and Spencer (1995), we analyze NI as a lexical alternation. To account for the contrast between Classifier NI and Compounding NI we rely on the distinction between word and lexeme. We argue that Compounding NI involves the formation of a new lexeme; Classifier NI involves the formation of a new word. Chukchi NI (i.e. Compounding NI) is the result of a Lexeme-to-Lexeme type; Ainu NI (i.e. Classifier NI) is the result of a Word-to-Word type.

4. An HPSG analysis of NI

A formal account of Noun Incorporation in the HPSG formalism is presented in Malouf (1999). He proposes a binary lexical rule, i.e. a lexical rule that takes two signs as its input, to account for NI in West-Greenlandic. We also adopt the idea of the binary rule, but we couch our analysis in terms of

The insight we are basing our analysis on is that Classifier NI is similar to cliticization in Romance. Like a Romance clitic, the incorporated noun is the expression of a verbal argument that is suppressed from the syntactic tree, but not from the argument structure of the predicate. Following Miller and Sag’s (1997) treatment of French clitics, we analyze such suppressed complements as noncanonical NPs in ARGST. Also, like cliticization, the suppression of the complement does not affect the transitivity of the predicate. This is the main reason to leave a noncanonical NP in ARGST. Note, however, that as in the case of Romance clitics, NI languages may vary on whether and to what extent they allow “doubling” (and/or “stranding”) of the incorporated nominal, as discussed in Mithun (1984) and Rosen (1989). More work needs to be carried out to determine the formal nature of such doubling and stranding.

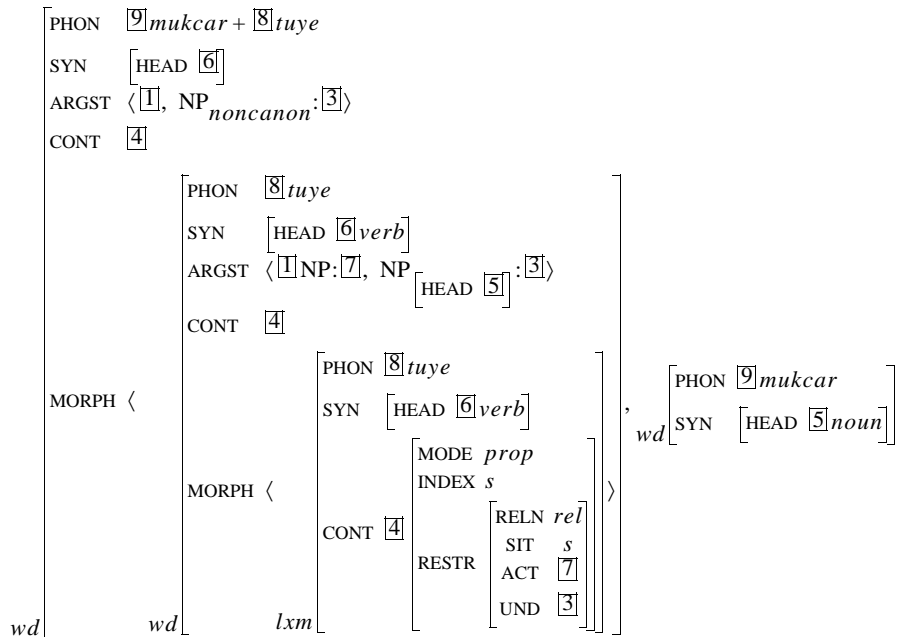

Figure (6): A Classifier NI verb in Ainu

Above, in Figure 6, is a feature description for the Ainu incorporating verb *mukcar=tuye* ‘chest=cut’, as it appears in sentence (4b). The MORPH value of the outermost word is a list that contains two words: the base verb and the incorporated noun. The base verb contains a lexeme, the arguments of which are linked to ARGST according to the linking principles in Figure 3, above. The outermost ARGST, however, is not identical to the ARGST of the innermost verb. In particular, the object (i.e. the second NP) is of type noncanonical, which means it will not be realized as a valence

feature. Its presence in ARGST, however, ensures that the verb remains transitive (this accounts for the presence of the A-type agreement marker on the verb in (4b)). The index assigned to this noncanonical NP ([3]) corresponds to that of the incorporated noun. The incorporated noun shares its head features (tagged [5]) with the object of the base verb (i.e. the NP that corresponds to the noncanonical NP in the outermost ARGST). Notice that the CONTENT of the incorporating verb (tagged [4]) is identical to that of the base verb.

Compounding NI, of the kind found in Chukchi, reduces the number of semantic arguments of the verb that are available to project to ARGST. The change in transitivity in the incorporating verb indicates that one of the semantic arguments of the base verb is saturated in the lexicon, by being assigned a denotation (i.e. an index) before the syntax gets a chance to do so. This argument, then, must not be represented in ARGST. Since this kind of argument saturation amounts to a change in meaning between the base verb and the incorporating verb, we claim the word-formation type for Compounding NI cannot have *words* as input or output, but rather *lexemes*. This is shown in Figure 7. Since lexemes do not have ARGST features, incorporation consists of the saturation of one of the semantic arguments of the incorporating verb by the incorporated nominal.³ To achieve this, we specify that the restriction of the verbal compound is the concatenation of the restrictions of the morphological roots. This is analogous to the way in which the meaning of a VP is compositionally determined by the meanings of the head verb and its complements in HPSG (Sag and Wasow 1999). Semantically, then, an incorporating verb is as complex as a VP, but from a syntactic point of view it is still a lexical, not a phrasal, object.

$$\begin{array}{c}
 \left[\begin{array}{l}
 \text{CONT} \left[\text{RESTR} \langle [3], [5] \rangle \\
 \text{MORPH} \langle \begin{array}{l}
 \text{vb-lxm} \left[\text{CONT|RESTR} [3] \left[\begin{array}{l} \text{RELN } rel \\ \text{UND} [4] \end{array} \right] \right], \\
 \text{n-lxm} \left[\text{CONT|RESTR} [5] \left[\begin{array}{l} \text{RELN } rel \\ \text{ARG} [4] \end{array} \right] \right] \rangle
 \end{array} \right]
 \end{array} \right]
 \end{array}$$

Figure (7): Compounding NI type constraint

In Compounding NI there is a mismatch between the number of unrestricted indices of the base verb and those of the compound verb. This difference correlates with the difference in valence between the incorporating verb and the base verb when it does not incorporate a noun. To account for

3. A matter of continued research is whether this is indeed a case of “saturation” vs. “merger” in the sense of Chung & Ladusaw (to appear).

this correlation we introduce convention that blocks linking of the restricted incorporated argument to ARGST.

Argument Saturation Convention: The set of indices linked to ARGST is the set of unsaturated indices in the CONTENT of the verb. An index is saturated if it is linked to a nominal index.

By virtue of the Argument Saturation Convention, the saturated argument in Compounding NI will not be linked to any element of ARGST, resulting in the desired reduction in valence. Figure 8 shows the linking in the lexeme-to-word type that takes place in Compounding NI.

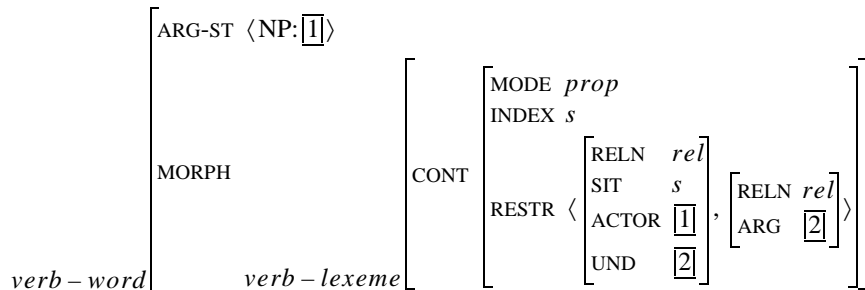

Figure (8): Linking to ARGST in Compounding NI

Below, in Figure 9, is the feature structure corresponding to the compound verb *matqə=rkele-* 'butter=spread.on', as it was used in sentence (3b). Notice the innermost MORPH feature, which has a list of lexemes as its value (a verb lexeme, and a noun lexeme). These lexemes combine to yield another lexeme, the compound verb. This lexeme must appear as the MORPH value of a word, since it is in the transition from the lexeme to the word that linking takes place. The Actor is linked to the first (subject) member of ARGST, while the Location is linked to a locative NP (by a linking constraint we do not spell out here). Notice that the Undergoer is not linked to any member of ARGST, because it is bound to the restriction of the incorporated noun in the restriction of the compound verb. The Argument Saturation Convention prevents this argument from being linked. The ARGST of this feature structure, then, corresponds to that of an intransitive verb, since there is no direct object. This account for the reduction in transitivity that can be observed in (3b).

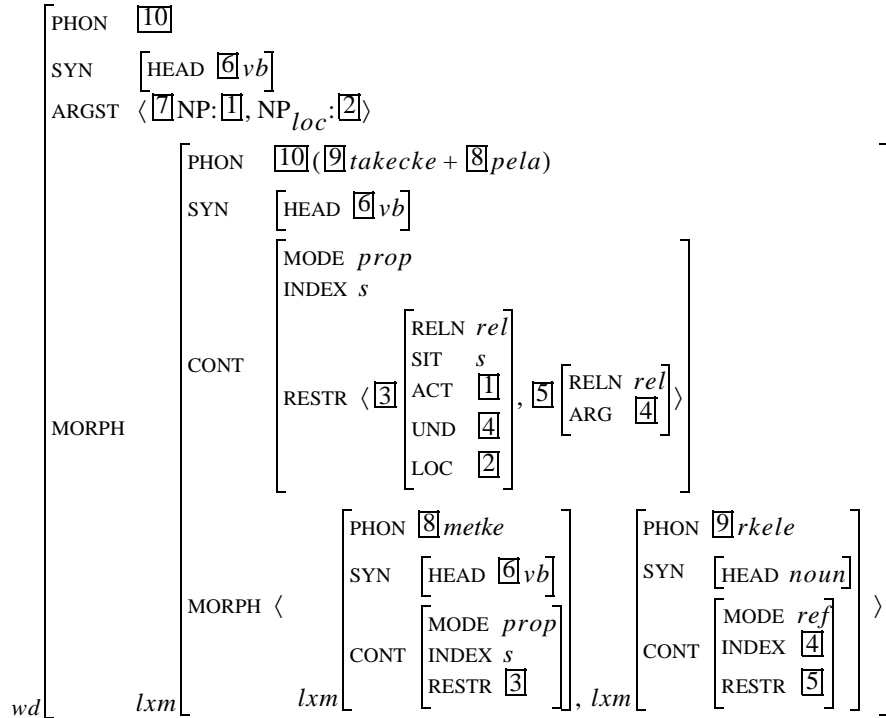

Figure (9): A verb with an incorporated noun in Chukchi

5. Noun incorporation and the applicative construction

Applicative Formation (AF) in Chukchi and Ainu is a productive construction in which a non-object is “promoted” to object. AF affects the grammatical functions of a predicate, not its lexical semantics. As Figure 10 shows we treat AF as a W-to-W type. The input is a word with an ARGST containing a non-object; the output is a word with an ARGST containing a direct object.

$$word \left[\begin{array}{l} ARGST \langle [1], NP:[3], ([2]) \rangle \oplus [4] \\ MORPH \quad word \left[ARGST \langle [1] NP, ([2] NP), XP:[3] \rangle \oplus [4] L \right] \end{array} \right]$$

Figure (10): Applicative Formation type constraint

Our account of AF in these languages makes the following predictions. Classifier NI should be able to feed AF. The input to AF is of type *word*, and the output of Classifier NI is also a word. This is shown in the schematic feature structure in Figure (11). Also, AF should be able to feed Classifier NI since the input to Classifier NI is a word with an ARGST containing

a direct object NP. This is shown in the schematic feature structure in Figure (12).

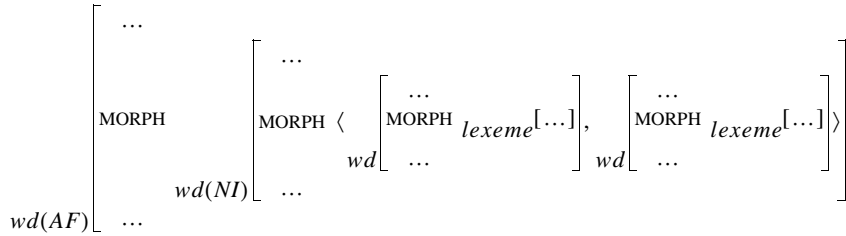

Figure (11): Classifier Noun Incorporation feeds Applicative Formation

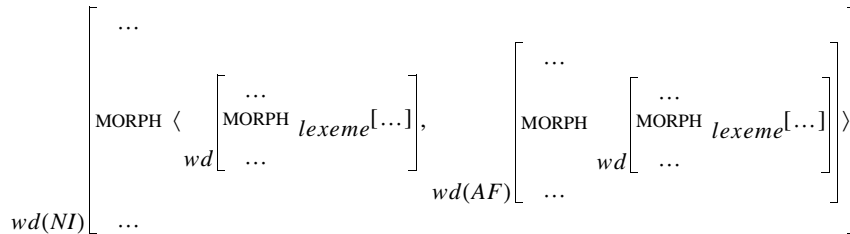

Figure (12): Applicative Formation feeds Classifier Noun Incorporation

Compounding NI should be able to feed AF too, since the output of Compounding NI is a word (even though Compounding NI creates a new lexeme). The schematic feature structure in Figure 13 shows this.

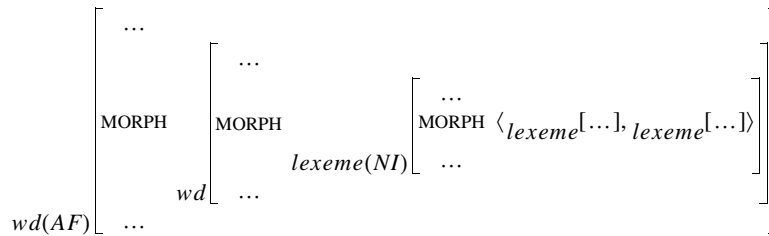

Figure (13): Compounding NI feeds Applicative Formation

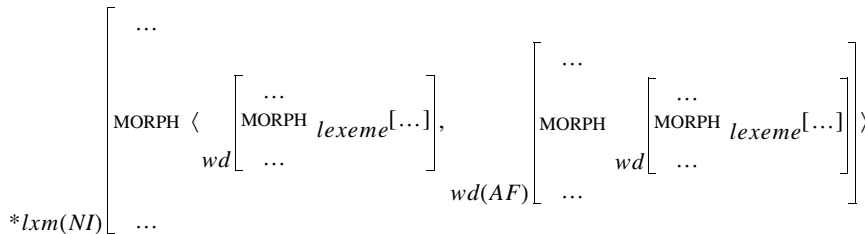

Figure (14): Applicative Formation cannot feed Compounding NI

But AF should not feed Compounding NI since the input to Compounding NI is a lexeme, not a word. This is shown in the schematic feature structure in Figure (14). We now show that these predictions are fulfilled in Ainu and Chukchi, respectively.

Beginning with Ainu, Applicative Formation (Shibatani, 1990, Kaiser 1998) is indicated by one of three prefixes: *e-*, *ko-*, or *o-*, the choice of the applicative prefix being determined by the grammatical function of the oblique. A range of non-objects can be promoted to object (5b).

- (5) a. *a-kor kotan ta sirepa-an*. [AINU]
 1sA-have village to arrive-1sg.S
 b. *a-kor kotan a-e-sirepa*.
 1sA-have village 1sA-appl-arrive
 ‘I arrived at my village.’

In Chukchi Applicative Formation (Spencer 1995) an oblique can become an object when an original object is demoted. Object demotion may be the result of Antipassive (AP) (6b) or of Noun Incorporation. The oblique NP bears one of several non-nuclear cases rather than being in a PP. No applicative affix appears in the verb after AF takes place (6b) (note that *ena-* is the antipassive marker).

- (6) a. *atlæg-e təkəčʔ-ən utkučʔ-ək pela-nen* [CHUKCHI]
 father-erg bait-abs trap-loc leave-3sgS/3sgO
 b. *atlæg-e təkəčʔ-a utkučʔ-ən ena-pela-nen*
 father-erg bait-instr trap-abs ap-leave-3sgS/3sgO
 ‘The father left the bait at the trap.’
- (7) a. *Tam-kurpoki a-ko-tam-etaye*. [AINU]
 sword-bottom 1s.A-appl-sword-draw.out
 ‘I drew the sword out from the bottom of the (other) sword.’
 b. *Ratki apa a-sapa-e-puni*.
 hung door 1s.A-head-appl-lift
 ‘I lifted the suspended door with my head.’
- (8) a. *atlæg-e utkučʔ-ən təkəčʔə=pela-nen* [CHUKCHI]
 father-erg trap-abs bait=leave-3sgS/3sgO
 b. **atlæg-ən təkəčʔ-a utkučʔə=pela-gʔe*
 father-abs bait-instr trap=leave-3sgS
 ‘The father left the bait at the trap.’

In Ainu (7a) as well as in Chukchi (8a) underlying objects can incorporate, and then AF may promote an oblique to object. However, AF can feed NI in Ainu (7b), but AF cannot feed NI in Chukchi (8b).

The example in (7b) shows that a nominal promoted to object in Ainu as a result of AF can subsequently be incorporated. This is reflected in the order between the IN and the applicative prefix (*ratki apa* ‘hung door’ is a secondary object). Example (8b) shows that a locative cannot be incorporated in Chukchi, not even after Antipassive and AF promote the oblique to object (note that the antipassive affix does not cooccur with the incorporated noun, cf. Kozinski et al. 1988).

Figure 15 illustrates Applicative Formation and Noun Incorporation in Ainu, as in the verb complex *-sapa-e-puni* ‘head-appl-lift’, from (7b). In this language AF “feeds” NI, since the input for the NI type is a word. What is important to notice is that in the most deeply embedded MORPH we find a base word (a verb) whose ARGST contains an XP indexed [3]; this index is shared with the NP in the output ARGST of AF. That ARGST is part of the input to NI. The head value ([5]) of the NP indexed [3] is shared with the incorporated noun. The output ARGST now indicates that the NP indexed [3] is non-canonical and thus will not license a NP in the phrase structure.

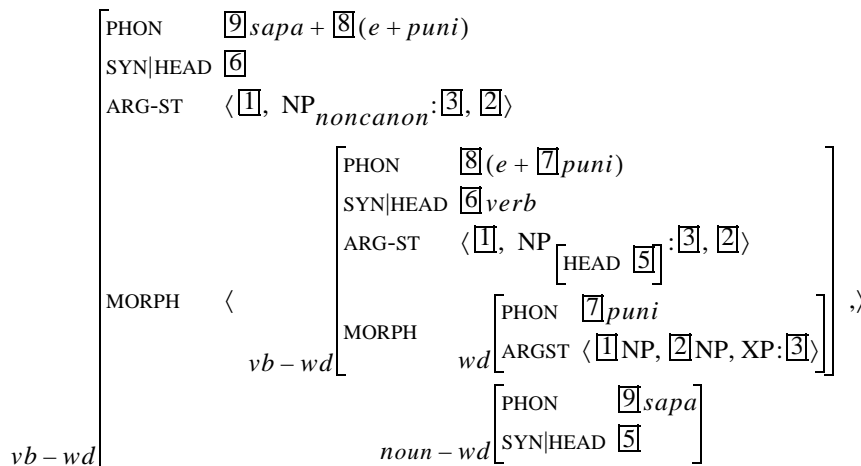

Figure (15): Incorporation of AF-derived object in Ainu

NI can also feed applicative formation in Ainu, since both types are words. Figure 16 illustrates the verb complex *-ko-tam-etaye* ‘appl-sword-draw.out’, from (7a). The MORPH value of the feature structure in Figure 16 is the feature structure for a verb + incorporated noun, similar to the one in Figure 6. The inner verb’s ARGST contains a non-canonical NP (the gap left by the incorporated noun, indexed [3]) and also a PP (indexed [2]). That PP is the phrase targeted by AF, so that the outer ARGST now has a direct object

NP sharing the same index as the input oblique PP ([2]).

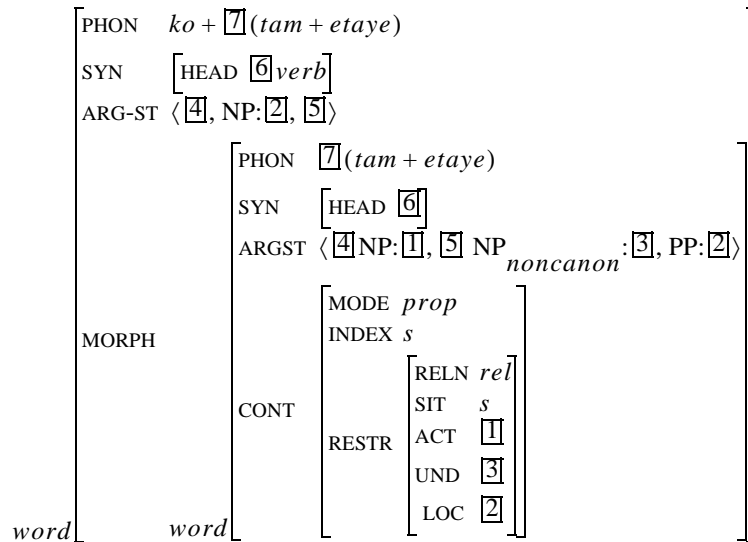

Figure (16): Applicative formation following NI in Ainu

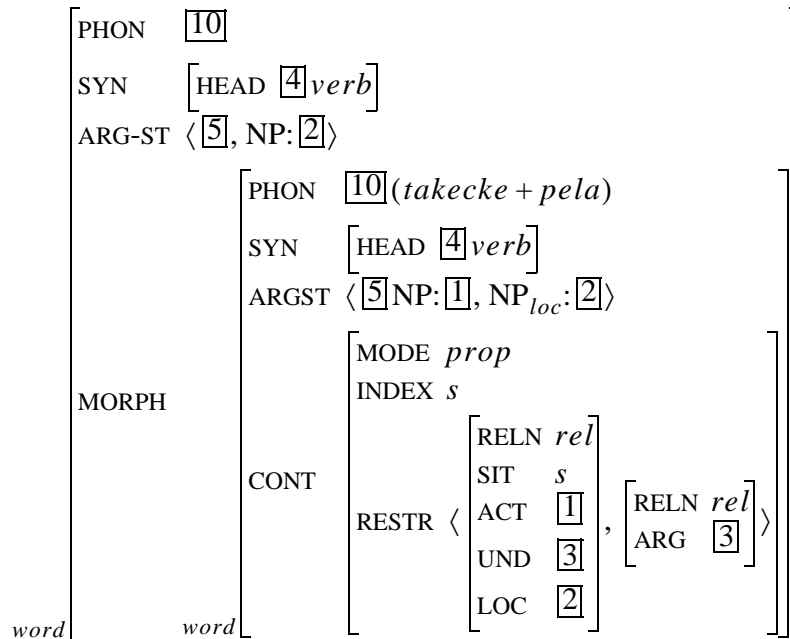

Figure (17): Applicative verb with incorporated noun in Chukchi

In Chukchi, NI can feed AF, because lexemes can be part of words. Figure 17 illustrates the verb complex *takečʔa=pela-* ‘bait=leave’, from

(8a). Here the inner word type is a verb with an incorporated noun, as in Figure 9. In that feature structure there were two lexemes that combined to create a new NI lexeme. That lexeme was then associated with an ARGST which contained a locative NP. This NP, indexed [2] in Figure 17, provides the input for Applicative Formation; the original locative NP ends up a direct object NP in the output ARGST.

What is crucial to our argument is that there is no possible type which has Applicative Formation inside Compounding NI, because word types cannot be the value of a lexeme's morph attribute. Thus, it follows from our analysis that such constructions do not exist in Chukchi (cf., *(8b)).

To summarize our argument, we began with the observation, which we suggest may be an important generalization, that the kind of NI that reduces the valence of the verb is the kind that *cannot* be fed by AF. We derived this with our type-inclusion solution (analogous to a level-ordering solution): Word formation constraints (WFCs) are assigned different types. WFCs of type *word* cannot be part of WFCs of type *lexeme*. Thus, this model can capture the correlation between type inclusion (i.e. rule ordering) and the linguistic properties of those types. WFCs that change lexical semantics are always included in (i.e. precede) WFCs that preserve lexical semantics because the type that can have mismatches in lexical semantics (the *lexeme*) is strictly included in the type that may not have mismatches in lexical semantics (the *word*)

Our observation/generalization about the contrasting properties of NI in Chukchi and Ainu offers evidence for different types of WFCs, and for the Split Lexicon Hypothesis. Recasting Wasow's distinction between lexical and syntactic rules in terms of L-to-L or W-to-W type constraints allows us to account for systematic differences between otherwise superficially similar constructions (Dative Shift and the Locative Alternation, as discussed in Aranovich and Runner (2001), and here Compounding NI and Classifier NI)

6. Consequences

The main argument presented above focuses on the different constraints on lexemes and words, and that words contain lexemes but not vice versa. The model we propose also illuminates the notion of "transitivity". In particular, if our approach is correct, the level of Argument Structure is the only level at which the notion of the transitivity of a predicate is represented.

To clarify this, let us consider the various ways in which the syntactic and semantic features of a predicate effect its transitivity in HPSG. Gapped (wh-extracted) arguments appear on ARGST as noncanonical phrases; these phrases do not license valence features, so no overt syntactic constituent is

projected (in the VP). Such gapping/extraction, though, is not generally assumed to affect the transitivity of the predicate. Likewise, cliticized arguments, which appear on ARGST as noncanonical elements, do not license valence features; this also does not affect transitivity. And in our analysis, Classifier NI incorporated nominals, which appear on ARGST as noncanonical elements, do not license valence features nor project syntactic structure; and these arguments do not affect the overall transitivity of the predicate. On the other hand, Compounding NI incorporated nominals, which appear in CONTENT but not in ARGST, do affect transitivity.

Thus, operations that affect valency (wh-extraction, Classifier NI) do not affect ARGST, and do not affect transitivity. Operations that do affect ARGST (e.g., Compounding NI) do affect transitivity. It appears, then, that the ARGST level is the locus of the notion transitivity. If correct, this observation makes predictions about the analysis of other transitivity-affecting operations in the grammar.

Several important questions are left open by our analysis thus far and will require further research to determine the appropriate answers. Our claim that lexemes are not defined for ARGST makes several predictions. First, if there are verbs which obligatorily take subject expletives (e.g., weather verbs), do these lexemes need ARGST in order to ensure the appearance of the expletive subject? An approach to this might claim that rather than giving in and requiring ARGST on every lexeme (no matter how predictable its form), for the few idiosyncratic verb types that appear to require such information, a subtype of lexeme (e.g., *expl-vb-lexeme*) can easily be defined that will map onto a word containing an expletive in its ARGST.

Second, in languages with “quirky” case, do these verbal lexemes need ARGST in order to ensure that the idiosyncratic case shows up on their subject? Again rather than giving up the claim that lexemes lack ARGST it may be possible that what is idiosyncratic in these languages is the linking to ARGST from CONTENT; that certain verb types trigger a special linking between particular CONTENT features and particular ARGST positions.

Third, it is a fact that many languages with Classifier NI, including Ainu, allow the incorporation of unaccusative subjects: if Classifier NI is insensitive to CONTENT features how can it pick out an unaccusative subject from an unergative subject? A possible approach to this problem is argued for in Manning (1996) (and has been developed elsewhere, see in particular Williams 1980), where it is argued that the ARGST list includes an indication of the notion “internal” vs. “external” argument. If this could be worked out, then Classifier NI picks out the most prominent (leftmost) internal argument nominal. This would require no reference to the actual underlying thematic relations within CONTENT (in addition, it is clear that the unaccusativity/unergativity of a predicate is more likely due to a complex

interaction of thematic role and aspectual information).

Finally, a question that needs to be addressed is the analysis of doubling in Classifier NI. Ainu does not allow doubling of the incorporated nominal, allowing us to provide an analysis parallel to French cliticization. However, Classifier NI languages vary on whether and to what extent doubling is allowed. We see this as the same problem as the question of clitic-doubling across Romance and other language families. While French does not allow clitic-doubling, Spanish does under certain circumstances. We look to analyses of e.g., Spanish clitic-doubling for insights into the analysis of Classifier NI doubling (and at present, we know of no such analyses).

This paper is one part of an on-going project exploring the Split Lexicon Hypothesis presented here. In Aranovich and Runner (2001) we used the Split Lexicon Hypothesis to provide an analysis of certain distinctions between the locative alternation and dative shift in English. In this paper we use the Split Lexicon Hypothesis to explain differences between Compounding and Classifier Noun Incorporation. Many other phenomena have been argued to divide into qualitatively distinct classes of alternations, such as different types of causatives (Zubizarreta 1987, Kuroda 1993), adjective vs verbal passives (Wasow 1977), native vs. latinate compounds in English (Selkirk 1984), and certainly others. It is our hope to investigate some of these phenomena through the lense of the Split Lexicon Hypothesis in order to shed light on their properties.

References

- Ackerman, Farrell (1992) 'Complex Predicates and Morpholexical Relatedness: Locative Alternation in Hungarian'. In Sag, Ivan, and Anna Szabolcsi (eds.) *Lexical Matters*. Stanford: CSLI Publications. 55-83.
- Anderson, Stephen (1977) 'Comments on the Paper by Wasow'. In P. Culicover, T. Wasow, and A. Akmajian (eds.) *Formal Syntax*. New York: Academic Press.
- Aranovich, Raúl, and Runner, Jeffrey T. (2001) 'Diathesis Alternations and Rule Ordering in the Lexicon.' In, K. Megerdooimian & L.A. Bar-el (eds.) *WCCFL 20 Proceedings* Somerville, MA: Cascadilla Press.
- Bresnan, Joan (1982). 'The Passive in Lexical Theory.' In Joan Bresnan (ed.), *The Mental Representation of Grammatical Relations*. Cambridge: MIT Press. 3-86.
- Briscoe, Ted, and Copestake, Ann (1999) 'Lexical Rules in Constraint-Based Grammars'. *Computational Linguistics* 25. 487-526.
- Davis, Anthony, and Jean-Pierre Koenig (2000). 'Linking as Constraints on Word Classes in a Hierarchical Lexicon.' *Language* 76. 56-91.
- Gerds, Donna (1998) 'Incorporation.' *The Handbook of Morphology*. Oxford: Basil Blackwell. 84-100.
- Kaiser, Lizanne (1998). 'The Interaction of Noun Incorporation and Applicative Formation in Ainu.' In Geert Booij and Jaap van Marle (eds.), *Yearbook of Morphology 1997*. Dordrecht: Kluwer. 157-178.
- Koenig, Jean-Pierre (1999) *Lexical Relations*. Stanford: CSLI Publications.
- Koenig, Jean-Pierre, and Anthony Davis (2001). 'Sublexical Modality and the Structure of Lexical Semantic Representations.' *Linguistics and Philosophy* 24. 71-124.
- Kozinsky, Isaac, Vladimir Nedjalkov, and Maria Polinskaja (1988). 'Antipassive in Chukchee: Oblique Object, Object Incorporation, Zero Object.' In Masayoshi Shibatani (ed.), *Passive and Voice*. Amsterdam: J. Benjamins. 651-706.
- Kuroda, S.-Y. (1993). 'Lexical and Productive Causatives in Japanese: An Examination of the Theory of Paradigmatic Structure.' *Journal of Japanese Linguistics* 15. 1-81.
- Manning, Christopher (1996) *Ergativity: Argument Structure and Grammatical Relations*. Stanford, CA: CLSI.

- Miller, Philip, and Ivan Sag (1997). 'French Clitic Movement without Clitics or Movement.' *Natural Language and Linguistic Theory* 15. 573-639.
- Mithun, Marianne (1984). 'The Evolution of Noun Incorporation.' *Language* 60. 847-894.
- Malouf, Robert (1999). 'West Greenlandic Noun Incorporation in a Monohierarchical Theory of Grammar.' In Gert Webelhuth, Jean-Pierre Koenig and Andreas Kathol (eds.), *Lexical and Constructional Aspects of Linguistic Explanation*. Stanford: CSLI Publications. 47-62.
- Rosen, Sarah T. (1989). 'Two types of Noun Incorporation: A Lexical Analysis.' *Language* 65. 294-317.
- Sag, Ivan A., and Thomas Wasow (1999). *Syntactic Theory: A Formal Introduction*. Stanford: CSLI Publications.
- Selkirk, Elisabeth (1982). *The Syntax of Words*. Cambridge, MA: MIT Press.
- Shibatani, Masayoshi (1990). *The Languages of Japan*. Cambridge: Cambridge University Press.
- Spencer, Andrew (1995). 'Incorporation in Chukchi.' *Language* 71. 439-489.
- Wasow, Thomas (1977). 'Transformations and the Lexicon.' In Peter W. Culicover, Thomas Wasow, and Adrian Akmajian (eds.), *Formal Syntax*. New York: Academic Press. 327-360.
- Wasow, Thomas (1981). 'Major and Minor Rules in Lexical Grammar'. In Hoekstra, Teun, Harry van der Hulst, and Michael Moortgat (eds.) *Lexical Grammar*. Dordrecht: Foris. 285-315.
- Williams, Edwin (1980). 'Predication.' *Linguistic Inquiry* 11. 203-238.
- Zubizarreta, Maria L. (1987) *Levels of Representation in the Lexicon and in the Syntax*. Dordrecht: Foris.

A compositional and constraint-based approach to non-sentential utterances

David Schlangen 

University of Edinburgh

Alex Lascarides 

University of Edinburgh

Proceedings of the 10th International Conference on
Head-Driven Phrase Structure Grammar

Michigan State University

Stefan Müller (Editor)

2003

Stanford, CA: CSLI Publications

pages 380–390

Schlangen, David & Alex Lascarides. 2003. A compositional and constraint-based approach to non-sentential utterances. In Stefan Müller (ed.), *Proceedings of the 10th International Conference on Head-Driven Phrase Structure Grammar, Michigan State University*, 380–390. Stanford, CA: CSLI Publications. DOI: 10.21248/hpsg.2003.21. 

Abstract

We present an approach to the interpretation of non-sentential utterances like B's utterance in the following mini-dialogue: A: "Who came to the party?" B: "Peter." Such utterances pose several puzzles: they convey 'sentence-type' messages (propositions, questions or request) while being of non-sentential form; and they are constrained both semantically and syntactically by the context. We address these puzzles in our approach which is compositional, since we provide a formal semantics for such fragments independent of their context, and constraint-based because resolution is based on collecting contextual constraints.

1 Introduction

In the following examples, B's utterances are *non-sentential*, consisting only of phrases, possibly modified by an adverb:

- (1) a. A: Who likes Peter?
b. B: Definitely he himself.
c. A: Peter came to the party.
d. B: Mary's cousin?
- (2) a. A: What did he make you do?
b. B: Kill JFK.
c. A: What did he force you to do?
d. B: To kill JFK.
- (3) a. A: On whom can we rely?
b. B: On Sandy.
c. A: Who did you see?
d. B: #On Sandy.
- (4) a. A: Peter left very early.
b. B: Exams.

Such non-sentential utterances pose several puzzles. First, even though the utterances are non-sentential, their intended meaning is of semantic types typically associated with full sentences, such as propositions and questions. This content is partially determined by contextual information.

Second, as (Morgan 1973, Morgan 1989) pointed out, the computation of this intended meaning cannot always rely solely on semantic or pragmatic information: eg., the fragment (2-d) cannot felicitously be used to answer (2-a), even though presumably the semantic type of (2-d) is the same as that of (2-b). Similarly, the preposition in (3-b)—a verb particle—is normally considered to be semantically empty,¹ and hence is not represented in the semantics. However, (3-b) is not felicitous as an answer to the question (3-c).

¹Cf. eg. (Pollard & Sag 1994).

Third, the reconstruction cannot solely work on syntactic structure either. As (Ginzburg 1999) points out, examples like (1-b) are incompatible with a syntactic approach, since their likely reconstruct “definitely he himself likes Peter” is ungrammatical. To this kind of counter example (Barton 1990) adds examples like (4), where apparently additional information has to be inferred.

Hence, the evidence seems to be contradictory, at the same time favouring and opposing both syntactic and semantic approaches to resolution. In this paper we present a way out of this impasse. We offer an analysis of the syntax and compositional semantics of these utterances, couched in the framework of HPSG (Pollard & Sag 1994, Sag 1997). We briefly describe an implementation of this analysis in a wide-coverage HPSG, and evaluate the impact of adding these rules. We then describe how the HPSG-analysis interfaces with a theory of discourse interpretation, and how this theory can explain the puzzle, given limited access to syntactic information. Finally, we compare our approach to that of (Ginzburg & Sag 2001), who offer a radically unmodular approach where information from grammar and from discourse is not distinguished. We show that our approach has advantages both in terms of coverage (we can deal with examples like (4)) and also in theoretical terms. From this we draw some general conclusions about how interaction between grammars like HPSG and contextual interpretation is best modelled.

2 A grammar of fragments

2.1 The Analysis

Our grammatical analysis of fragments like that in the previous examples is relatively straightforward: we make the assumption that fragments are phrases,² possibly modified by adverbs. As (5) shows, only scopally modifying adverbs are allowed.

- (5) A: Who sang this song?
B: Maybe Sandy. / *Badly Sandy.

In a pseudo phrase-structure notation, the rules simply are of the form ‘S-frag → (ADV) XP’. We formalise this in a version of HPSG that allows *constructions* (Sag 1997), ie. phrase-types that make a semantic contribution. Unlike (Pollard & Sag 1994) we do not use situation semantics as the framework for our semantic representations but rather MRS (Copestake et al. 1999), which supports semantic underspecification (cf. (Reyle 1993)). We will say more about the semantics of this formalism below. For now we just note that MRS-representations consist of a feature INDEX whose value represents the semantic index of the sign; a feature LTOP that holds the *handle* of the sign, ie. a label for the bits of logical form introduced

²This goes back to (Morgan 1973); explicit rules can be found in (Barton 1990). We ignore for now more complicated examples like ‘A: Does John devour or nibble at his food? — B: Oh, John devours.’

by it; LZT, which is a bag of labelled *elementary predications* (EPS); and H-CONS, which collects constraints on the order of sub-formulae.

The formalisation is best explained with an example. Figure 1 shows, in a tree representation, the sign for the NP-fragment “Peter.” It shows how the NP is lifted to the level of sentences, and how the semantics of that sentence is composed.

Let’s work our way ‘top-down’ to describe this Figure in detail. The root-sign in this tree has all the syntactic features of a sentence: the value of its `SYNSEM.LOCAL.CAT` is of type *verb*, and all valence requirements are satisfied. It is also semantically like a sentence, in that its top-EP (with the handle $\boxed{2}$) is of type *message* (more precisely, a *propstn*). This EP is contributed by the fragment-rule, via the feature `C-CONT` (construction content). In the same way an *unknown*-constraint is introduced, which is an anaphoric element expressing the underspecification in the content of fragments, as will be explained below. The connection of this constraint to the semantics of the phrase is made via co-indexation of the argument-slot of *unknown* with the `INDEX` of the argument phrase (in Figure 1 this is $\boxed{5}$).

As the type-declaration in Figure 1 shows, this sign is the combination of two types, namely *headed-phrase*, which is a general type that defines the features and co-indexations in headed phrases; and *np-nm-decl-frag*, which collects the specifications particular to fragments. This type in turn inherits from three further types: *np-frag*, which specifies the particularities of fragments consisting of NPs; *nm-frag*, which specifies non-modified fragments (ie., a phrase that is not modified by an adverb); and *decl-frag*, which indicates that the fragments resolves to a proposition. These three types encapsulate properties of fragments that can vary independently, and build the hierarchy shown in Figure 2.

We assume a generalised head-feature principle (*ghfp*) as in (Ginzburg & Sag 2001) according to which all values for `SYNSEM`-features on the mother are by default token-identical to those of the daughter, and hence we have to make sure that the fragment-types override this default where appropriate. For example, the value for `SYNSEM.LOCAL` of fragments must be specified on the types for the fragments, since it will always be different from that of the head daughter—raising different XPs to sentences after all is the whole point of the rule, and so the default of the *ghfp* to copy these specifications must be overridden. The value of `SYNSEM.LOCAL.CAT` will be the same for all types of fragments, namely that of a sentence. In fact, the only elements of the type instantiated in Figure 1 that are specific to NP-fragments are the co-indexation of the `INDEX` of the head (the NP) with the `ARG` of the *unknown*-rel, and the restriction that the phrase be an NP. So the constraint unique to NP-fragments (ie., the specification of the type *np-frag*) is simply that shown in (6).

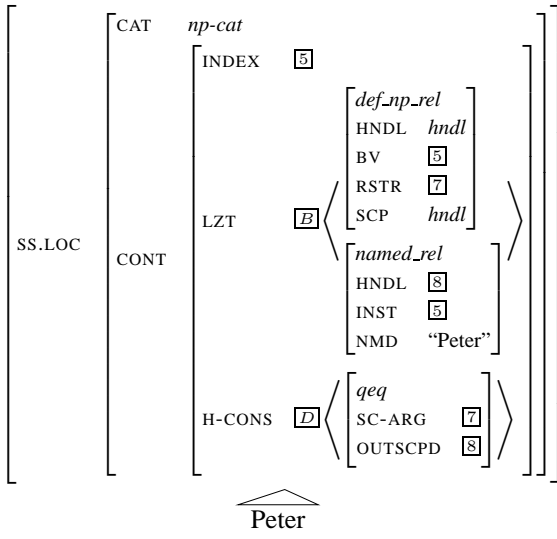
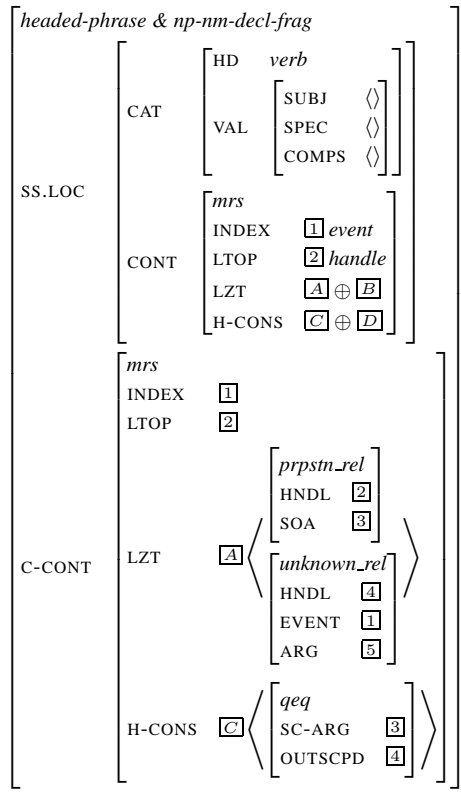

Figure 1: "Peter" as a declarative fragment.

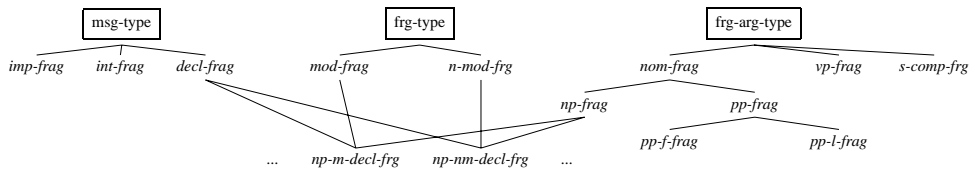

Figure 2: An extract of the construction hierarchy for fragments

(6) *np-frag*:

$$\left[\text{C-CONT.LZT} \left\langle \left[\right], \left[\text{ARG} \boxed{1} \right] \right\rangle \right] \rightarrow$$

$$\mathbf{H} \left[\text{SYNSEM.LOCAL} \left[\text{CAT} \left[\begin{array}{l} \text{HEAD } \textit{nominal} \\ \text{VAL} \left[\begin{array}{l} \text{COMPS} \langle \rangle \\ \text{SPR} \langle \rangle \end{array} \right] \end{array} \right] \right] \right] \right]$$

$$\left[\text{CONT.INDEX} \boxed{1} \right]$$

The example we have seen above is one of a non-modified fragment. In fragments that are modified by an adverb, we find an additional non-head-daughter, whose EP is scoped in as sister to the *unknown_rel*, as shown in (7).

(7)

$$\left[\textit{mod-frag} \left[\begin{array}{l} \text{C-CONT} \left[\begin{array}{l} \textit{mrs} \\ \text{LZT} \left\langle \left[\begin{array}{l} \textit{prpstn_rel} \\ \text{HN DL} \boxed{2} \\ \text{SOA} \boxed{3} \end{array} \right] , \left[\begin{array}{l} \textit{unknown_rel} \\ \text{HN DL} \boxed{4} \end{array} \right] \right\rangle \\ \text{H-CONS} \left\langle \left[\begin{array}{l} \textit{qeq} \\ \text{SC-ARG} \boxed{3} \\ \text{OUTSCPD} \boxed{4} \end{array} \right] , \left[\begin{array}{l} \textit{qeq} \\ \text{SC-ARG} \boxed{3} \\ \text{OUTSCPD} \boxed{5} \end{array} \right] \right\rangle \end{array} \right] \\ \text{NON-HEAD-DTRS} \left\langle \left[\text{SYNSEM} \left[\begin{array}{l} \textit{scopal_vp_adv} \\ \text{LOCAL.CONT.TOP} \boxed{5} \end{array} \right] \right] \right\rangle \end{array} \right] \right]$$

Finally, the last dimension organises the differences in the type of message to which the fragment will resolve. The example we have seen in Figure 1 was one of a propositional-fragment; fragmental questions or requests only differ in the type of this topmost-relation. To give an example, (8) shows the type *int(errogative)-frag(ment)*.

(8)

$$\left[\textit{int-frag} \left[\text{C-CONT.LZT} \left\langle \left[\textit{int} \right], \dots \right\rangle \right] \right]$$

<i>Version of Grammar</i>	<i>Average # parses</i>
LinGO ERG, 20/11/02	2.86
ERG+frag	3.69

Table 1: Competence comparison of the original ERG with the fragment-ERG

The rules in this dimension also make sure that *wh*-phrases can only be *int*-frags.

This concludes our brief presentation of our syntactic analysis of fragments, for more details see (Schlangen & Lascarides 2003) or (Schlangen 2003).

2.2 Implementation

We have implemented our analysis in a wide-coverage HPSG, the *English Resource Grammar* (ERG, see for example (Copestake & Flickinger 2000));³ the implementation was evaluated using the grammar-profiling tool [`incr tsdb()`] (Open & Flickinger 1998). First, to test for possible adverse effects on the analyses of full-sentences, we ran a batch-parse of a test-suite of full sentences, the CSLI-test-suite which is distributed with [`incr tsdb()`]. It consists of 1348 sentences, of which 961 are marked as syntactically well-formed and 387 as ill-formed. Table 1 shows a comparison of the original ERG with our extended version containing the fragment rules, with respect to the average number of parses per sentence.

As these data show, the fragments rules do introduce some new ambiguity, but on average less than one more parse per item. We conclude from this that adding these fragment-rules doesn't lead to an explosion of readings that would render the grammar practically unusable. What this evaluation doesn't tell us, however, is whether the additional readings (of what is meant to be full sentences) are erroneous or not. The problem is that 'fragmenthood' is not a syntactic criterion, and so some strings that can be analysed as sentences can also be analysed as fragments. (E.g., (2-b) above is both an imperative sentence and a VP-fragment.)

To test the coverage of our extended grammar with regards to fragments, we manually marked up all fragments in a corpus of dialogue examples (from the Verbmobil-project, cf. (Wahlster 2000)). In 4037 items we identified 369 fragments, of which our grammar correctly parsed 242 (= 65.5%). A detailed study of the fragments that were not recognised showed that a useful extension would be rules for handling fragments of the form "CONJ XP", eg. "and on Saturday."; including those would bring our coverage up to 82.6% of the corpus.

³The implementation differs slightly from the analysis described in the previous section: the ERG doesn't make use of defaults, and so we had to explicitly state what is identical between mother and daughter and what isn't.

3 Semantics and Resolution

As mentioned above, the basic element of our compositional semantics of fragments is the relation *unknown_rel*. In a different notation, the compositional semantics we gave for the fragment “Peter” in Figure 1 is as shown in (9).

$$(9) \quad \langle h, e, \{ h:prpstn_rel(h_1), h_2:unknown_rel(e, x), \\ h_6:def_np_rel(x, h_8, h_9), \\ h_{10}:named(x, Peter) \}, \\ \{ h_1 =_q h_2, h_8 =_q h_{10} \} \rangle$$

This formula expresses that all we know about the meaning of the fragment *independent from its context* is that a) it will resolve to a proposition, of which b) the main predicate is unknown, but c) one participant in the main event of the proposition is specified, even though its exact role isn’t. For details of the formal semantics of this relation, please see (Schlangen 2003).⁴

These descriptions are augmented via a theory of discourse interpretation, SDRT (Asher & Lascarides 2003). This theory attempts “to enrich dynamic semantics with techniques for encoding the contribution of pragmatics” (Asher & Lascarides 2003, p.180). One central notion of dynamic semantics (eg. (Kamp & Reyle 1993)) is the update of a representation of the context with that of new information; in SDRT, this update is dependent on non-monotonic inferences over linguistic and non-linguistic information. SDRT’s update-operation is defined on descriptions like MRSS; it simply adds constraints on the form of logical forms. The inferred information that is most important for us is the *speech act type* that connects the new information to the context (for in SDRT speech acts are *relations*, to reflect the fact that the successful performance is logically dependent on the context). We only sketch the basic idea here, and refer the interested reader to (Schlangen 2003). The inferred speech act type determines the resolution of fragments, by adding further constraints to the description. For example, the information that (1-b) is an *answer* to (1-a) (we call the relation *QAP* for *question-answer-pair*) or that (4-b) offers an *Explanation* for (4-a) resolves in this approach the underspecification in the fragment.

One last element is missing in the explanation of the puzzles from Section 1. We make a distinction between fragments that are resolved by identifying certain elements from the context with the underspecified relation (as for example in complement questions: “Peter” as an answer to “Who came to the party?” is resolved via identifying a certain sub-formula of the question with the ‘missing’ content of the fragment) and fragments that are resolved via inference that possibly uses world-knowledge (as must be the case for (4)). We explain the puzzle by allowing *update* limited access to syntactic information when resolving the first kind of fragments; more specifically, the *update* is only coherent if the subcategorisation

⁴Note the similarity between the use of descriptions in the semantics to that of descriptions in HPSG: where we use MRSS to describe (possibly sets of) logical forms, HPSG uses attribute-value-matrices to describe (possibly sets of) feature structures.

requirements of the elements that take the fragment as argument are met. This explains the pattern in (2) and (3), while allowing (4) to be free of syntactic influence. For details on how this method can also explain the apparent syntactic constraints on fragments where optional elements are ‘filled’ by the fragment (as in “A: I made a purchase. — B: Another pair of shoes?”), please see (Schlangen 2003).

4 Related Work

As mentioned in the introduction, (Ginzburg & Sag 2001) (henceforth G&S) offer a non-modular approach to the resolution of short-answers (and some other fragmental speech acts). (10) shows a very schematic representation of their approach.

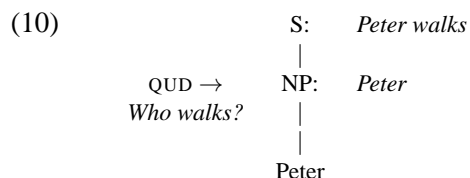

A grammar rule specific to the *use* made of the fragment (in (10) as an answer) directly projects NPs as sentences, with parts of the sentential content coming from a contextual feature QUD (question under discussion). This grammar rule in one go checks the syntactic constraints and constructs the intended content of the fragment.

In our view, our compositional approach has certain advantages. First, the grammatical analysis of fragments is uniform; contextual variation in their meaning is accounted for in the same way as it is for other anaphoric phenomena, via inferences underlying discourse update. This yields the second advantage: resolving fragments is fully integrated with resolving other kinds of underspecification (as described in detail in (Schlangen 2003)). Third, the interaction between grammar and pragmatics is straightforward: pragmatics enriches information coming from the grammar. In G&S’s approach the grammar has to ‘decide’ on the speech act that has been performed (the grammar-rules are specific for eg. answering, clarification); something that is normally seen to be a defeasible process. Hence, even in G&S’s approach a pragmatic module is required, which then has the task of filtering out unwanted parses. Fourth, we have available a strong theory of contextual interpretation which can explain the reasoning behind the resolution of examples like (4) (although we have not shown here in detail how); the functional application used by G&S seems too weak to do this. Fifth, our compositional approach allowed us to relatively straightforwardly extend an existing wide-coverage grammar; the requirement of the non-compositional approach to have available contextual information entails that standard parsers cannot be used without modifications. Finally, we think the use of the feature CONTEXT in G&S’s approach is problematic: since it is assumed to hold information about the context of the utterance, HPSG-signs can no longer be seen as representations of *types* of linguistic entities. Note that it

is not possible to view CONTEXT as a repository for restrictions on the *use* of the type modelled by the sign, as is done for example in the analysis of honorifics in HPSG, since for every possible fragment phrase there is an infinite number of ways the CONTEXT-feature can be specified (since the fragment can be for example an answer to an infinite number of questions).

5 Conclusions and Further Work

We have presented the outline of a compositional and constraint-based approach to non-sentential utterances. The basic elements of this approach are a grammar of fragments, which produces an underspecified semantic representation of their compositional semantics, ie. a representation of their content independent from their context. This representation consists of constraints that describe logical forms. As a third element we have shown how our approach interfaces with a theory of discourse interpretation, SDRT. We have briefly discussed why we think a compositional approach is advantageous.

As further work we plan to analyse the syntax and semantics of fragments that begin with conjunctions, e.g. “And Peter.” or “Or maybe on Sunday?”, which as we have shown are relatively frequent in dialogue corpora.

Acknowledgements

We would like to thank Viktor Tron and Chris Callison-Burch for comments on earlier versions of the paper, and also the reviewers and participants of HPSG03 for their helpful comments.

References

- Asher, N. & Lascarides, A. (2003), *Logics of Conversation*, Cambridge University Press.
- Barton, E. L. (1990), *Nonsentential Constituents*, John Benjamins, Amsterdam / Philadelphia.
- Copestake, A. & Flickinger, D. (2000), An open source grammar development environment and broad-coverage english grammar using HPSG, in ‘Proceedings of the 2nd Linguistic Resources and Evaluation Conference’, Athens, Greece, pp. 591–600.
- Copestake, A., Flickinger, D., Sag, I. & Pollard, C. (1999), Minimal recursion semantics: An introduction. Stanford University, Stanford, CA.
*<http://www-csli.stanford.edu/~aac/papers/newmrs.ps>
- Ginzburg, J. (1999), Semantically-based ellipsis resolution with syntactic presuppositions, in H. Bunt & R. Muskens, eds, ‘Computing Meaning: Current issues in computational semantics’, Kluwer, Dordrecht.
- Ginzburg, J. & Sag, I. A. (2001), *Interrogative Investigations: The Form, Meaning, and Use of English Interrogatives*, number 123 in ‘CSLI Lecture Notes’, CSLI Publications, Stanford.
- Kamp, H. & Reyle, U. (1993), *From Discourse to Logic*, Kluwer, Dordrecht.
- Morgan, J. L. (1973), Sentence fragments and the notion ‘sentence’, in ‘Issues in Linguistics: Essays in honour of Henry and Rene Kahane’, UIP, Urbana.

- Morgan, J. L. (1989), Sentence fragments revisited, in B. Music, R. Graczyk & C. Wiltshire, eds, 'Papers from the 25th regional meeting of the Chicago Linguistics Society Part Two: Parasession on Language in Context', Chicago, USA, pp. 228–241.
- Oepen, S. & Flickinger, D. P. (1998), 'Towards systematic grammar profiling: Test suite technology ten years after', *Journal of Computer Speech and Language: Special Issue on Evaluation* **12**(4), 411–437.
- Pollard, C. & Sag, I. (1994), *Head-Driven Phrase Structure Grammar*, CSLI / The University of Chicago Press, Chicago and London.
- Reyle, U. (1993), 'Dealing with ambiguities by underspecification: Construction, representation and deduction', *Journal of Semantics* **10**, 123–179.
- Sag, I. A. (1997), 'English relative clause constructions', *Journal of Linguistics* **33**(2), 431–484.
- Schlangen, D. (2003), A Coherence-Based Approach to the Interpretation of Non-Sentential Utterances in Dialogue, PhD thesis, School of Informatics, University of Edinburgh, Edinburgh, UK.
- Schlangen, D. & Lascarides, A. (2003), The interpretation of non-sentential utterances in dialogue, in A. Rudnicky, ed., 'Proceedings of the 4th SIGdial workshop on Discourse and Dialogue', Sapporo, Japan.
- Wahlster, W., ed. (2000), *Verbmobil: Foundations of Speech-to-Speech Translation*, Springer, Berlin.

On the notion “determiner”

Frank Van Eynde 

University of Leuven

Proceedings of the 10th International Conference on
Head-Driven Phrase Structure Grammar

Michigan State University

Stefan Müller (Editor)

2003

Stanford, CA: CSLI Publications

pages 391–396

Van Eynde, Frank. 2003. On the notion “determiner”. In Stefan Müller (ed.), *Proceedings of the 10th International Conference on Head-Driven Phrase Structure Grammar*; Michigan State University, 391–396. Stanford, CA: CSLI Publications. DOI: 10.21248/hpsg.2003.22.



Abstract

Following a common practice in generative grammar, HPSG treats the determiners as members of a separate functional part of speech (DET), just like the complementizers, the coordinating conjunctions, and (in some frameworks) the auxiliaries. The status of such functional parts of speech is a matter of debate and controversy. The auxiliaries, for instance, are commonly treated as members of a separate category (AUX or INFL) in many variants of generative grammar, including GB, MP and LFG, but in GPSG and HPSG, it is a matter of equally common practice to treat them as members of V and to reject the postulation of a separate functional category, see (Pullum and Wilson 1977) and (Gazdar, Pullum and Sag 1982). This text makes a similar case for the determiners; more specifically, I will argue that they are categorially heterogeneous, in the sense that some determiners are members of A, whereas others are members of N. The argumentation is mainly based on inflectional morphology and on morpho-syntactic agreement data. The consequences of the categorial heterogeneity are hard to reconcile with the specifier treatment of the determiners of (Pollard and Sag 1994), and even more with the Det-as-head treatment of (Netter 1994), but it can smoothly be integrated in the functor treatment of the prenominals of (Allegranza 1998) and (Van Eynde 2003b).

1 The categorial heterogeneity of the determiners

Adopting the classical X-bar distinction between specifiers and adjuncts, as proposed in (Chomsky 1970), (Pollard and Sag 1994) treats the determiners as specifiers and the other prenominal dependents as adjuncts. In *his many beautiful pictures*, for instance, the possessive is a specifier, whereas *many* and *beautiful* are adjuncts. Adjuncts are optional and can be stacked; specifiers, by contrast, are sometimes obligatory, as in the case of singular count nouns in English, and cannot be stacked, as in **the his pictures*. Moreover, adjuncts are projections of substantive categories (N,V,A,P), whereas specifiers are projections of functional categories, such as DET.

This systematic correlation between syntactic function (specifier of NP) and part of speech (determiner) is unfortunate and had better be removed, both for methodological and empirical reasons. Methodologically, it goes against the grain of cross-categorial generalization which is typical of X-bar syntax and of the HPSG framework. A complement or a head, for instance, can belong to any kind of category; so why should a specifier be a priori restricted to belong to one particular part of speech (Det)? Empirically, there is ample evidence from various languages that the set of words which are standardly treated as determiners is a rather heterogeneous collection which comprises both signs with adjectival properties and signs with nominal properties. Some of this evidence will be presented in this section.

	[SG,MASC]	[SG,FEM]	[PL,MASC]	[PL,FEM]	
Adj	<i>alto</i>	<i>alta</i>	<i>alti</i>	<i>alte</i>	high
	<i>facile</i>	<i>facile</i>	<i>facili</i>	<i>facili</i>	easy
Dem	<i>questo</i>	<i>questa</i>	<i>questi</i>	<i>queste</i>	this
Wh	<i>quale</i>	<i>quale</i>	<i>quali</i>	<i>quali</i>	which

Table 1: The forms of the Italian pronominals

	[-AGR,-DCL]	[-AGR,+DCL]	[+AGR]			
Adj	<i>goed</i>	<i>goede</i>	<i>goeden</i>	<i>goeder</i>	<i>goeds</i>	good
	<i>koel</i>	<i>koele</i>	<i>koelen</i>			cool
Poss	<i>ons</i>	<i>onze</i>	<i>onzen</i>	<i>onzer</i>	<i>onzes</i>	our
Dem		<i>deze</i>		<i>dezer</i>		this
Wh	<i>welk</i>	<i>welke</i>				which

Table 2: The forms of the Dutch pronominals

1.1 Adjectival determiners

In languages in which the pronominal adjectives show inflectional variation, one commonly finds the same variation in the case of the determiners. In Italian, for instance, the demonstratives show the same variation with respect to gender and number as the pronominal adjectives which end in *-o*; similarly, the *wh*-determiner *quale* ‘which’ shows the same variation as the adjectives which end in *-e*, see table 1. The same holds for the Dutch determiners. Their variation in terms of agreement (AGR) and declension (DCL) mirrors the one of the pronominal adjectives, see table 2.¹

This similarity in inflectional variation is significant, since it is one of the main criteria for motivating part of speech membership: a word like *operation*, for instance, is treated as a noun, since it inflects like a noun, and the fact that its meaning is closely related to the one of a verb, does not matter in this respect. In keeping with this practice, I will assume that the determiners in tables 1 and 2 are members of A. Further evidence for this assumption is provided by the fact that the determiners are subject to the same agreement constraints as the pronominal adjectives. The Italian pronominals with the *-a* suffix, for instance, only combine with singular feminine nouns, both when they are adjectives and when they are determiners. In Dutch, the agreement facts are more complex than in Italian, but they confirm the observation that the determiners are subject to the same constraints as the pronominal adjectives, see (Van Eynde 2003a).

¹The forms with an AGR affix are either genitive or dative. They are not commonly used and therefore absent in many paradigms, but notice that such gaps occur both among the determiners and the pronominal adjectives.

1.2 (Pro)nominal determiners

The specifiers of NPs can also be genitives of proper nouns and pronouns. In Dutch, they are in complementary distribution with the possessive adjectives. Compare, for instance, *onze kat* ‘our cat’ with *Peters/wiens kat* ‘Pete’s/whose cat’. In terms of morphology and agreement, though, the genitives do not behave as adjectives.² They do not take any of the typically adjectival affixes, such as the declension affix,³ and they do not show any agreement with the head noun. Compare, for instance, the agreement in case, number and gender between the possessive and the head noun in *mijns/*mijn inziens* ‘my-GEN insight-GEN’ with the lack of agreement between the genitive NPs and the head noun in *Peters/wiens boeken* ‘Pete’s/whose books’, in which the prenominal is a singular masculine genitive, whereas the head noun is a plural neuter noun in standard case. This lack of agreement can also be observed in the combination of a noun with a prenominal adjunct of the category common noun, as in *aluminium tubes*, in which the singular mass noun *aluminium* does not show agreement with the plural count noun *tubes*.

Another class of NP specifiers with nominal characteristics are the non-genitive pronouns. As an example, let us take the Italian interrogative *che* ‘what’; this pronoun is not only used as an argument of the verb, as in *che dici?* ‘what say-you’, but also as a prenominal, as in *che/quali intenzioni hai?* ‘what/which intentions have-you’. In this use, it has the same meaning and function as *quale* ‘which’, but in contrast to the latter it does not show any adjectival morphology or agreement. A similar example is the Dutch quantifying *wat* ‘some(thing)’; it can be used as the argument of a verb, as in *er is nog wat over* ‘there is still some left’, but also as a prenominal, as in *er zijn nog wat erwten* ‘there are still some peas’. In that use, the singular *wat* does not show any agreement with the head noun *erwten*, which demonstrates that it behaves like a (pro)noun rather than like an adjectival determiner.

Summing up, the specifiers of NP do not belong to a separate part of speech, but are either adjectives or nouns. In the former case they show the same inflectional variation and the same agreement as the prenominal adjectives, in the latter, they do not show any agreement.

2 Accommodating the categorial heterogeneity

The conclusion of the previous section is a problem for the treatment of the determiners as **specifiers** in (Pollard and Sag 1994), for if determiners belong to either A or N, then there is no categorial basis anymore for the distinction between specifiers and adjuncts. Further complications arise when one adopts the assumption, also made in (Pollard and Sag 1994), that the nouns lexically select their specifier, for in that case the value of the selecting feature (SPR) will be $\langle A|N \rangle$, so

²In contrast to the English possessive ‘s, which can be argued to be a word which takes an NP as its specifier, as in (Pollard and Sag 1994), the Dutch -s is a genitive affix.

³The affix in the pronoun *ikke* ‘I-EMP’ is not a marker of declension, but of emphasis.

that the addition of an adjectival or nominal adjunct will inadvertently trigger the cancellation of the noun's SPR requirement.

The conclusion is even more problematic for the DetP style analysis in (Netter 1994). Netter treats the determiners as **heads** which take a nominal projection as their complement and—in order to get a uniform result for nominals with and without determiner—claims that the determiner inherits the category of its complement, i.e. N. As a result, it cannot accommodate the fact that most of the determiners are adjectival. Moreover, since the determiners also inherit the HEAD|AGR value of their nominal complement, which includes case, number and gender, it erroneously predicts that genitive NPs have to show agreement with the head noun.

A treatment which is compatible with the findings of the previous section is the one of (Allegranza 1998) and (Van Eynde 2003b). They treat the determiners as **functors** which select a nominal projection as their head and which contribute their MARKING value to the combination.

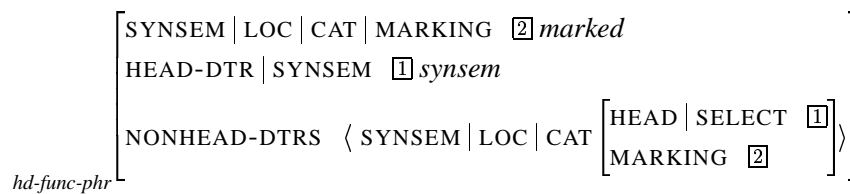

This phrase type models all combinations in which the non-head daughter selects the head daughter, and hence subsumes the *head-adjunct*, *head-specifier* and *head-marker* phrase types of (Pollard and Sag 1994). The differences between determiners and pronominal adjectives are captured in terms of the MARKING value. They both select an unmarked nominal, but while the MARKING value of the determiners is *marked*, the one of the adjectives is *unmarked*. This accounts for the fact that adjectives can be stacked, whereas the determiners cannot, as well as for the fact that the determiners must precede the adjectives.⁴

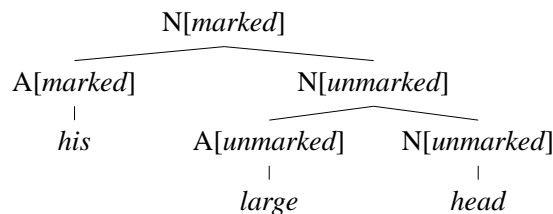

This treatment has no problem with the categorial heterogeneity of the determiners, for since the determiner status is captured in the MARKING value and since the HEAD value of the determiner is not shared with the NP, one gets a uniform NP

⁴The distinction captured by the MARKING value is not a semantic one. The possessives, for instance, are marked in Dutch and English, but not in Italian, cf. *il suo cane* 'the his dog'. Similarly, while the English quantifying *each* is marked, its near-synonym *every* is not, cf. *his every move* and *where a film's every truckling nuance is debated* (TIME, January 13, 2003, 50).

analysis, both when the determiner is an adjective and when it is a (pro)noun. At the same time, the part of speech distinction provides the means to differentiate the agreeing adjectival determiners from the non-agreeing nominal ones.

3 Conclusion

Determiners do not belong to a separate functional category, but are categorially heterogeneous: some are adjectives, others (pro)nouns. This is a problem for the specifier treatment of (Pollard and Sag 1994) and for the head treatment of (Netter 1994), but not for the functor treatment of (Allegranza 1998) and (Van Eynde 2003b). The latter's emphasis of the different roles of HEAD and MARKING values allows for a cleaner distinction between form and function.

References

- Allegranza, V. (1998). Determiners as functors: NP structure in Italian, in S. Balari and L. Dini (eds), *Romance in HPSG*, CSLI Publications, Stanford, pp. 55–107.
- Chomsky, N. (1970). Remarks on nominalization, in R. Jacobs and P. Rosenbaum (eds), *Readings in English transformational grammar*, Ginn and Company, Waltham, Mass., pp. 184–221.
- Gazdar, G., Pullum, G. and Sag, I. (1982). Auxiliaries and related phenomena in a restrictive theory of grammar, *Language* **58**: 591–638.
- Netter, K. (1994). Towards a theory of functional heads: German nominal phrases, in J. Nerbonne, K. Netter and C. Pollard (eds), *German in HPSG*, CSLI Publications, Stanford, pp. 297–340.
- Pollard, C. and Sag, I. (1994). *Head-driven Phrase Structure Grammar*, CSLI Publications and University of Chicago Press, Stanford/Chicago.
- Pullum, G. and Wilson, D. (1977). Autonomous syntax and the analysis of auxiliaries, *Language* **53**: 741–788.
- Van Eynde, F. (2003a). Morpho-syntactic agreement and index agreement in Dutch NPs, in T. Gaustad (ed.), *Computational Linguistics in the Netherlands 2002. Selected Papers from the Thirteenth CLIN Meeting*, Rodopi, Amsterdam - New York, pp. 111–127.
- Van Eynde, F. (2003b). Prenominals in Dutch, in J.-B. Kim and S. Wechsler (eds), *Proceedings of the 9th International Conference on HPSG*, CSLI Publications, Stanford University, pp. 333–356.

Specificational pseudoclefts in English

Eun-Jung Yoo 

Seoul National University

Proceedings of the 10th International Conference on
Head-Driven Phrase Structure Grammar

Michigan State University

Stefan Müller (Editor)

2003

Stanford, CA: CSLI Publications

pages 397–416

Yoo, Eun-Jung. 2003. Specificational pseudoclefts in English. In Stefan Müller (ed.), *Proceedings of the 10th International Conference on Head-Driven Phrase Structure Grammar, Michigan State University*, 397–416. Stanford, CA: CSLI Publications. DOI: 10.21248/hpsg.2003.23. 

Abstract

Specificational pseudoclefts (SPCs) have been a great challenge for a syntactic theory, because, despite the surface division between the pre- and post-copular elements, the post-copular ‘pivot’ behaves as if it occupied the gap position in the precopular *wh*-clause. This paper argues that movement-based or deletion-based syntactic approaches and purely semantic approaches have problems in dealing with syntactic properties and connectivity problems of SPCs in English. Observing the parallelism between SPC pivots and short answers to questions, it proposes an HPSG account based on a non-deletion-based QDT (Question-in-disguise theory) approach and on the equative analysis of the specificational copular sentences. The paper shows that SPCs must be handled by an integrated account of the syntactic, semantic, and pragmatic properties of the construction, and argues that the connectivity problems should be approached from such an integrated view.

1 Introduction

Specificational pseudoclefts (SPCs, henceforth) are copular sentences like (1) in which a *wh*-clause is equated with the focal phrase that corresponds to the gap in the *wh*-clause. The focal phrase in a SPC is often referred to as the pivot, whose category is as diverse as NP, AP, VP, and CP as illustrated in (1).

- (1) a. What he brought was a donkey.
- b. What they are is silly.
- c. What appeals to them most is a go on the swings.
- d. What he then did was cut his finger.
- e. What proves that your are wrong is that they weren’t even there. (Higgins 1979:2)

What has drawn many researchers’ interest in the investigation of SPCs is so called ‘connectivity’. The term connectivity refers to the observation that the pivot behaves as if it occupied the gap position in the precopular *wh*-clause. In (2a), for example, the pronoun has a bound variable reading as if it were in the same clause as *everyone*, and in (2b), the NPI *any* is licensed by the negation just as in a single clause.

- (2) a. What everyone_{*i*} proved was his_{*i*} own theory. (*Bound variable connectivity*)
- b. What he didn’t buy was any wine. (*NPI connectivity*)
- c. What John_{*i*} is is a nuisance to him_{**i/j*}. (*Binding Theory B connectivity*)
- d. What he_{**i/j*} is is a nuisance to John_{*i*}. (*Binding Theory C connectivity*)

It is well known that SPCs are distinguished from predicational pseudoclefts, in that only SPCs exhibit connectivity effects (Akmajian 1970, Higgins 1979). In predicational pseudocleft examples such as (3), the *wh*-clause is a free relative functioning as a referring expression, and the phrase following the *wh*-clause is the predicate. Thus unlike in (1b), the predicate in (3a) is predicated of some property of the *wh*-clause subject *Susan*, instead of being predicated of *Susan* directly.

- (3) a. What Susan is is worthwhile. (*Predicational pseudocleft*)
b. *What he didn't have bothered anyone.
c. What John_i is surprised him_i/*himself_i.
d. What she_i claimed is typical of Susan_i.

The examples in (3b-d) show that NPI connectivity and binding theory connectivity are not observed in predicational pseudoclefts.

As will be discussed in section 2, while some analyses of SPCs are tightly connected to a syntactic approach to connectivity problems, it has also been proposed that connectivity should be handled from a semantic perspective.

The main purpose of this paper is to investigate how SPCs in English can be accounted for within HPSG. This paper shows that SPCs must be handled by an integrated account of the syntactic, semantic, and pragmatic properties of the construction, and argues that the connectivity problems should be approached from such an integrated view.

The rest of the paper is organized as follows. In section 2, recent approaches to SPCs are briefly reviewed and their merits and problems are pointed out. Section 3 takes a closer look at the Question-in-disguise theory (QDT). More supporting arguments for the approach are discussed, together with certain problems and limitations that the deletion-based QDT approach has. Then it will be suggested that the post-copular elements in SPCs should be taken to be short answers, not full answers that undergo phonological deletion at PF. Next, section 4 presents a proposal that is based on a non-deletion-based QDT approach and an equative analysis of the copular *be*. Ginzburg & Sag's (2000) analysis of short answers is adopted to represent the SPC pivots. Lastly, in section 5, some possible accounts of bound variable connectivity and NPI connectivity are discussed, pointing out remaining issues concerning binding principle connectivity.

2 Syntactic and semantic approaches to SPCs

Recently there have been proposed three different approaches to SPCs. In what follows, I'll briefly review movement approaches, deletion-based QDT approaches, and semantic approaches to the SPC constructions, and discuss what aspects of the previous analyses can be adopted for my analysis.

2.1 Movement approaches

The basic assumption of a movement approach is that the pivot and the position of the gap in the *wh*-clause is linked by syntactic movement. Recent proposals advocating this approach include Bošković (1997), Meinunger (1998), and Heycock & Kroch (2002).

Bošković (1997) claims that the pivot moves to the gap position at LF, and that a pseudocleft sentence is identified with the corresponding unclefted sentence at this level, as shown in (4).

- (4) a. What he brought was a donkey.
b. He brought a donkey. (LF)

He claims that the *wh*-phrase is a surface anaphor that has the pivot as its antecedent, thus being replaced by the pivot at LF. More specifically, as the consequence of the competition for the same position between the *wh*-phrase and the pivot, the chain headed by the *wh*-phrase (or the initial trace position of the *wh*-phrase) is replaced by the pivot, being accompanied by the deletion of the *wh*-phrase.

On the other hand, Heycock & Kroch (2002) propose that SPCs have the same LF representation as non-copular sentences with the identical information structure. Therefore, all of (5a-c) have the same LF in (5d).

- (5) a. What she saw was two flamingos.
b. She saw [_F two flamingos].
c. [_F Two flamingos] she saw.
d. [_{FocP} [_{Focus} two flamingos_i] [_{Foc'} Foc⁰ [_{Ground} she saw t_i]]] (LF)

According to Heycock & Kroch, the Focus constituent in (5d) then undergoes obligatory reconstruction at LF, thus resulting in a unclefted counterpart of the cleft sentence.

In a movement approach, connectivity is dealt with by positing a structure in which the pivot and the material in the *wh*-clause are represented as clausemates. In this approach, a monoclausal analysis is tightly connected to the assumption that connectivity effects such as binding, NPI licensing, and bound variable licensing must be explained in terms of c-command.

However, Bošković's and Heycock & Kroch's analyses are problematic in some respects. First, in Bošković, the kind of movement that he proposes is quite odd in that the landing site is a trace position. Reconstruction to a trace position may occur at LF: however, if something should be reconstructed, it is the *wh*-phrase, not the pivot. Second, in Heycock & Kroch, it is not explained what precise mechanism derives the LF representation (5d) from (5a). Furthermore, given the same LF for (5a-c), it needs to be explicated why only (5a) has the specificational meaning. Third, both of Bošković and Heycock & Kroch cannot explain the example in (6),

because the movement (and the reconstruction) of the pivot wouldn't result in the expected simple sentence.

(6) What John did was [he bought some wine]. (Den Dikken et al. 2000:43)

Fourth, as Cecchetto (1999) points out, anti-connectivity effects stand against the key assumption of Bošković that a pseudocleft becomes identical to its unclefted counterpart at LF. Since Heycock & Kroch also derive an unclefted sentence as the final LF representation, the same problem arises in Heycock & Kroch. (Anti-connectivity effects will be discussed in section 3.4.)

2.2 Deletion-based QDT approaches

The second approach is a deletion approach that is based on Ross (1985, 1997), Schlenker (1998, 2003), and Den Dikken et al.'s (2000) *Question-in-disguise theory* (QDT). In this approach, the precopular constituent is taken to be a question in disguise and the postcopular phrase, the answer to the question. The parallelism is shown in (7).

- (7) a. What John likes is himself.
b. What does John like? (John likes) himself.

As illustrated in (8), a full answer form is posited at Spell-Out and LF, and the underlined form is assumed to be deleted at PF.

(8) What John likes is John likes himself.

This approach is appealing because it accounts for connectivity without postulating any unmotivated movement (including reconstruction). Since the connected clause appears in the pivot at SS, connectivity is explained via syntactic relations at this level. In addition, this approach captures parallelism between SPCs and question-answer pairs (for example, a uniqueness presupposition carried by a question and a precopular phrase in SPCs). It also accounts for the existence of the examples like (9) that contain a full answer form.

(9) What I did then was I called the grocer. (Ross 1972)

Furthermore, as Schlenker (2003) argues, this approach can be extended to cases of DP connectivity, such as *The person John likes is himself*, by assuming that the precopular DP is a concealed question in which the Definiteness feature of a concealed *wh*-word is spelled out by *the*.

Despite the advantages, this approach has limitations in explaining why only a subset of questions is permitted in precopular position, and what precise mechanism is at work for the deletion process. Moreover, as will be discussed in section 3.4, this approach is also undermined by some anti-connectivity effects (Sharvit 1999 and Cecchetto 2000).

2.3 Semantic approaches

The third one is a semantic approach that is sometimes called *Unconstrained-‘be’ theory* (Jacobson 1994, Heycock & Kroch 1999, Sharvit 1999, Cecchetto 2000, 2001).¹ This approach is based on the idea that a pseudocleft sentence is a true equative and the pre and post-copular phrases have the same denotation.

- (10) a. What John read was *War and Peace*.
b. $\text{Max}(\lambda y[\text{John read } y]) = \text{War and Peace}$
(“Max” is a uniqueness/maximality operator.)

In this approach, connectivity in SPCs is viewed as a purely semantic phenomenon that is not related to a structural condition like c-command. This view is based on the observation that bound pronouns may occur without c-command as in (11) (Jacobson 1994, Sharvit 1999).

- (11) The picture of himself that every student bought was a nuisance to him.
(For every student *x*, the picture of *x* that *x* bought was a nuisance to *x*.)

In Sharvit and Cecchetto, connectivity related to variable binding, binding theory, and NPI licensing is shown to arise from independent interpretive procedures or semantic constraints. For example, their account of BV connectivity is based on the “functional” analysis of *wh*-questions. BT B&C effects are viewed as a result of Reinhart’s (1983) rule, which expresses systematic preference for a bound variable interpretation over a coreferential interpretation.

We agree in vein with their conclusion that connectivity in SPCs can be accounted for in terms of semantics. However, it should be examined whether various syntactic behaviors of SPCs can be also reconciled with this approach. Syntactically, there is some evidence that a precopular *wh*-clause is an interrogative clause, rather than a free relative clause. This will be discussed in the next section.

3 More on a question-answer-pair analysis of pseudoclefts

While it has been pointed out that the deletion-based QDT approach has some problems, there are certain aspects of the question-answer-pair analysis that can be adopted for the account of SPCs. In this section, we will take a closer look at syntactic properties of precopular and post-copular elements in SPCs and discuss what similarities and dissimilarities between SPCs and question-answer-pairs should be taken into account.

¹Actually, Heycock & Kroch (1999) is hard to classify, since their analysis is based on both the equative sentence approach and a variant of reconstruction approach. However, in contrast to other reconstruction approaches, they argue that the derivation process of a connected sentence is semantic as well as syntactic, since it occurs after reaching the LF, mapping an interpreted structure onto another interpreted structure.

3.1 Similarities between SPC *wh*-clauses and interrogative clauses

In this subsection, we will examine similarities between SPC *wh*-clauses and interrogative clauses. First, as Ross (1985) shows, pseudocleft clauses behave like embedded interrogatives in that they license ‘what else’ and do not allow ‘whatever’. These properties contrast to free relatives, because free relatives do not permit ‘what else’, although they allow ‘whatever’ to occur freely.

- (12) a. I know [what else she cooked]. (interrogative)
b. *I ate [what else she cooked]. (FR)
c. [What (else) she is going to cook] is spaghetti flambé. (SPC)
- (13) a. I wonder [what(*ever) he is]. (interrogative)
b. I ate [whatever she cooked]. (FR)
c. [What(*ever) he is] is silly. (SPC)

Second, although marginal, it is possible that multiple *wh*-phrases appear in SPCs, unlike in free relatives. ((14a) is from Ross 1997, and (14b) from Den Dikken et al. 2000.)

- (14) a. ?[Who ordered what] was [Tom (ordered) a beer and Jim a watermelon flip].
b. ?[What John gave to whom] was [a book to Mary a CD to Sue].

Third, topicalization out of pseudoclefts is permitted as in interrogatives, which contrasts to the extraction possibilities in free relatives (Meinunger 1998).

- (15) a. ?To Mary, what I wouldn’t give is any wine.
b. ?To Mary, what will you give?
c. *To Mary, what I gave caused a scandal.

All these arguments present evidence that the SPC *wh*-clause is not a free relative. These facts support that precopular elements in SPCs are better analyzed as interrogatives.

3.2 Dissimilarities

It should be also mentioned that there are some differences between SPC *wh*-clauses and interrogatives. The examples in (16) are from Higgins (1979), and he observes that speakers vary with respect to the grammatical judgements. Certain speakers accept only some or all of the examples.

- (16) a. Who told me about it was Jane.
b. Where he spends his summers is Chester.
c. How he cut his face was by trying to eat while shaving.

- d. Why they did it was to impress Mary. (Higgins 1979:2)

The variability in judgements indicates that speakers vary as to which *wh*-phrases they allow in SPCs.

On the other hand, almost all speakers do not accept examples with *which*, *whose*, or *how many*, as in (17), and this clearly contrasts to interrogatives.

- (17) a. *Which hat John found was that one.
b. *Whose book John borrowed was Jane.
c. *How many books Jennifer read was five (books).
- (18) a. Which/whose hat did John find?
b. How many books did Jennifer read?

In addition, unlike in *wh*-questions, pied-piping of *wh*-phrases is not permitted as illustrated in (19).²

- (19) a. *With whom he went to the movie was with Jane.
b. *About what he is thinking is about his new movie.
- (20) a. To whom did he introduce Jane?
b. About which woman are they speaking?

Therefore, if we adopt a question-answer-pair analysis, these dissimilarities should be accounted for. Proposals regarding this problem will be discussed in section 4.3.

3.3 SPC pivots as (elided) answers

Putting aside the differences mentioned in 3.2, another supporting argument for the question-answer-pair analysis comes from the parallelism between SPC pivots and elided answers. First piece of evidence concerns the fact that full answers may appear in the pivot, as shown in (21).

- (21) a. What John did was he bought some wine. (Den Dikken et al. 2000:43)
b. What I did then was I called the grocer. (Ross 1972)

Existence of examples like (21a,b) is quite puzzling in a movement-based analysis or in a purely semantic approach.

Moreover, as shown in (22) to (24), scope of negation illustrates parallelism between the SPC pivots and elliptical answers (Higgins 1979, Bošković 1997, Den Dikken et al. 2000). Although (22a) is ambiguous between the readings in (22b) and (22c), the ambiguity does not occur in the SPC example in (23) and in the question-answer pairs in (24).

²It should be also noted that pied-piping is impossible in free relatives as well.

(i) *With whom he went to the cinema has just entered the room.

- (22) a. Jane does not believe that he will graduate. (*ambiguous*)
 b. Jane does not hold the belief that he will graduate.
 c. Jane holds the belief that he will not graduate.
- (23) ?What Jane does not believe is that he will graduate. (\neq 22c)
- (24) a. ??What Jane does not believe is [she does not believe that he will graduate] (\neq 22c)
 b. ?What does Jane not believe? That he will graduate. (\neq 22c)

The foregoing facts show that SPC pivots exhibit the same pattern as responses to questions with respect to negation scope. I take this to suggest that the Question-in-disguise theory has merits that can be adopted.

3.4 Anti-connectivity and a non-deletion-based QDT approach

One of the main obstacles for the existing QDT approaches is anti-connectivity. As mentioned in section 2, previous QDT approaches presuppose the occurrence of a full answer in the pivot. However, as Sharvit and Cecchetto observe, the connectivity observed in SPCs does not always coincide with that of question-full-answer pairs. Some examples of *anti-connectivity effects* are shown in (25) and (26).

- (25) a. What John thinks that Mary likes is himself.
 b. *John thinks that Mary likes himself.
 c. What does John think that Mary likes? Himself. (Schlenker 2003:203)
- (26) a. What some student admires is every teacher. (* $\forall\exists$)
 b. What some student admires is some student admires every teacher.
 c. What does some student admire? Every teacher. (* $\forall\exists$) (Cecchetto 2001:98-99)

In (25a), if a full answer appears in the pivot, as the proponents of the deletion-based approach claim, it should have a form in (25b). However, this is not possible because (25b) is an ungrammatical sentence. Therefore, the anti-connectivity effect in (25) cannot be explained in the deletion-based approach. It also posits a problem for the movement approach, because ungrammatical (25b) constitutes the LF representation of (25a).

Moreover, the deletion-based QDT approach (as well as the movement approach) cannot explain the absence of the wide scope reading of the universal quantifier in (26a). This is because, at SS and LF, (26a) will be of the form (26b), in which the pivot part should allow the wide scope reading of universal quantifier just as in the simple sentence *Some student admires every teacher*. (Cf. Cecchetto 2001)

On the other hand, as (25c) and (26c) exhibit, when we consider a context where short answers are used as responses to *wh*-questions, it becomes evident that SPC pivots correspond to such short answers. Thus parallelism holds between (25c) & (25a), and (26c) & (26a), respectively.

Accordingly, in our view, what is problematic with previous QDT approaches is the parallelism made between SPCs and question-full-answer pairs, which is accompanied by phonological deletion. We propose that the pivots in (25a) and (26a) be directly related to the short answers in (25c) and (26c) respectively. If we take into account *question-short-answer pairs*, the parallelism is more complete.

4 Proposed analysis

Now I will present a proposal based on a non-deletion-based QDT approach and the equative analysis of SPCS within the framework of HPSG. The first key to the analysis is the description of the copular *be*.

4.1 *Be-of-identity*

There have been a number of studies that have provided arguments for the analysis that specificational copular sentences are equatives, and the copular *be* in those sentences has the meaning of identity. (Partee 1986, Jacobson 1994, Sharvit 1999, Heycock & Kroch 1999, Schlenker 2003). Based on the arguments, we take SPCs to involve *be-of-identity*.

Now the question is how to equate the meaning of precopular elements with that of post-copular ones in HPSG representations. If we treat the precopular elements in SPCs as a *wh*-interrogative clause, its CONTENT would be of type *question*. However, in this case, the question meaning itself will not be identical to the meaning of the post-copular answer part.

What seems to be more appropriate is to say that it is the (resolving) answer to the precopular question that is equated with the post-copular element. This idea is incorporated in the lexical entry of *be* in (27).

(27) *be*

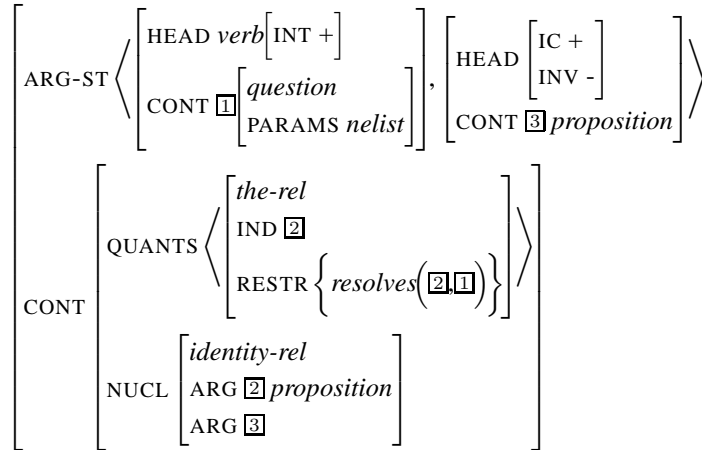

In (27), in order to represent the meaning of the precopular clause, I adopted and modified Ginzburg & Sag's (2000) coercion analysis for the interrogative complements of resolutive predicates such as the ones in (28).

(28) *Jane knows/discovered/forgot who passed the exam.*

In addition, I assume that indices can be employed for the representation of verbal projections as well as nominal ones (cf. Van Eynde 2000 and Sag & Wasow 1999). Thus the two arguments of *identity-rel* in (27) are expressed via propositional indices.

Now, given the entry in (27), let's consider how the analysis works.

1. First of all, since it is the (resolving) answer to the precopular question, not the question meaning itself that is equated with the post-copular element, the identity relation holds between two propositions without any type mismatch problem.
2. Second, as the semantic coercion of the pre-copular interrogative clause is stated in the lexical entry of *be*, it is consistent with Ginzburg & Sag's observation that interrogatives only manifest 'fact-denoting' behavior in embedded contexts.³
3. Third, since core properties of the construction are represented by the lexical entry of *be*, our analysis explains why a predicate of identity (i.e., the copula *be*) must be used in SPCs.
4. Next, the definite quantifier in the CONT of *be* is to accommodate the standard assumption that there exists a unique exhaustive answer to a question.

³While Ginzburg & Sag posit *fact* as a separate semantic object, in our analysis, both of Ginzburg & Sag's *fact* and *proposition* are represented by the type *proposition*.

Thus the CONT can be understood as expressing the meaning ‘The exhaustive (resolving) answer to the question represented by the first element in the ARG-ST is token-identical to the CONT of the second element’.⁴

5. Another consequence of the analysis is that it may rule out the occurrence of ‘indirect answers’ that are not allowed in the SPC pivot as in (32). While an ordinary question in (29a) may have either direct answers in (29b,c) or indirect answers in (30), SPC pivots allow only direct answers as shown in (31) and (32). This can be explained in my analysis, because the CONT of the pivot is required to be identical to that of the precopular clause. In the examples in (32), such identity does not hold between two propositions represented by pre- and post-copular elements.

- (29) a. What did John do?
 b. Buy a book.
 c. He bought a book.

- (30) a. I believe that he bought a book.
 b. I don’t know (what he did).
 c. BILL bought a book (... but I don’t know what John did).

- (31) a. [What John did] was [buy a book].
 b. [What John did] was [he bought a book].

- (32) a. *[What John did] was [I believe that he bought a book].
 b. *[What John did] was [I don’t know].
 c. *[What John did] was [BILL bought a book]. (Den Dikken et al. 2000:49)

6. Next, the second element in the ARG-ST is specified as [IC +] in order to represent that a short answer is a main-clause phenomena, although it appears in an embedded context in SPCs. (See section 4.2.)

7. In addition, the requirement that the second element in the *arg-st* be [IC +, INV -] indicates that the post-copular element should be an independent, noninverted clause (i.e., S or CP). Thus both a full clause or an elliptical clause that is [IC +] can appear in the SPC pivot.

⁴Although the two elements in the ARG-ST as is in (27) will appear as SUBJ and COMPS daughters respectively, we do not preclude the possibility of an alternative analysis wherein the first element is realized as a filler (i.e. as a topicalized phrase). See Hankamer 1974, Meinunger 1998, Den Dikken et al. 2000 for the latter position.

8. Finally, the requirement that the first ARG-ST element be [INT+] forces the precopular question to have an interrogative *wh*-phrase at the beginning, prohibiting the examples in (33). A more detailed discussion will be provided in section 4.3.

- (33) a. *[John bought what] is a book.
 b. *[To whom John gave a book] is to Jane.

4.2 SPC pivots as short answers

Now I will present the analysis of the SPC pivot. As mentioned, for ordinary SPCs, I take the post-copular part to correspond to the (elided) answer to a question. However, in contrast to Den Dikken et al. and Schlenker, it is not analyzed as involving phonological deletion. Instead, it will be analyzed in terms of *declarative-fragment-clause* (*decl-frag-cl*), which is proposed to handle short answers and reprise sluices in Ginzburg & Sag (2000).

In Ginzburg & Sag, *decl-frag-cl* is a subtype of the type *headed-fragment-phrase* (*hd-frag-ph*) and *decl-cl*.⁵ Following Ginzburg & Sag, the type constraints can be given as in (34) and (35).⁶

(34) *hd-frag-ph*:

$$\left[\begin{array}{l} \text{HEAD } verb[\text{VFORM } fin] \\ \text{SUBJ } < > \\ \text{SPR } < > \\ \text{CTXT|SAL-UTT } \left\{ \left[\begin{array}{l} \text{CAT } \boxed{1} \\ \text{CONT|IND } \boxed{2} \end{array} \right] \right\} \end{array} \right] \rightarrow \mathbf{H} \left[\begin{array}{l} \text{CAT } \boxed{1} \\ \text{CONT|IND } \boxed{2} \end{array} \right]$$

⁵For the type *hd-frag-ph*, we don't pose a restriction on the category of head daughter. This is different from Ginzburg & Sag, who limit the head daughter's category to nominal ones (i.e. nouns or prepositions).

⁶The QUANTS value of the clause is specified using a 'shuffle' relation. This permits a narrow scope interpretation of the quantifier(s) arising in the pivot with respect to the quantifiers present in the *wh*-clause.

(35) *decl-frag-cl*:

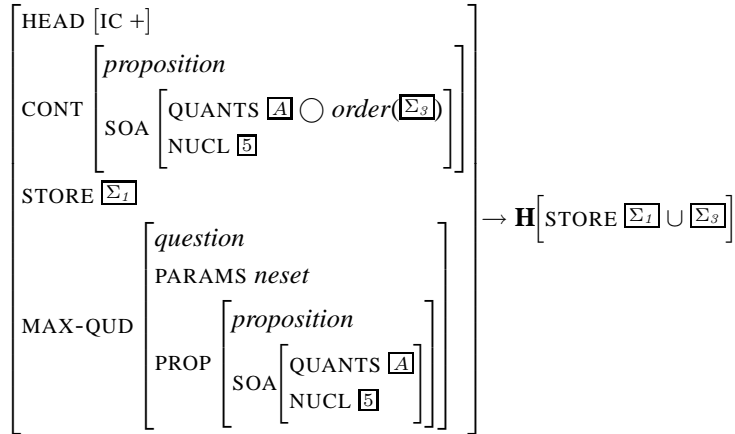

In Ginzburg & Sag, the CTXT is assumed to have two additional attributes, MAX-QUD and SAL(IENT)-UTT(ERANCE). The MAX-QUD is of type *question* and represents ‘the question currently under discussion’. On the other hand, the SAL-UTT, whose value is sets of type *local*, represents ‘the (sub)utterance that receives widest scope within MAX-QUD’, which is normally a *wh*-phrase.

The treatment of short answers is incorporated to my analysis of SPCs as in the following.

(36)

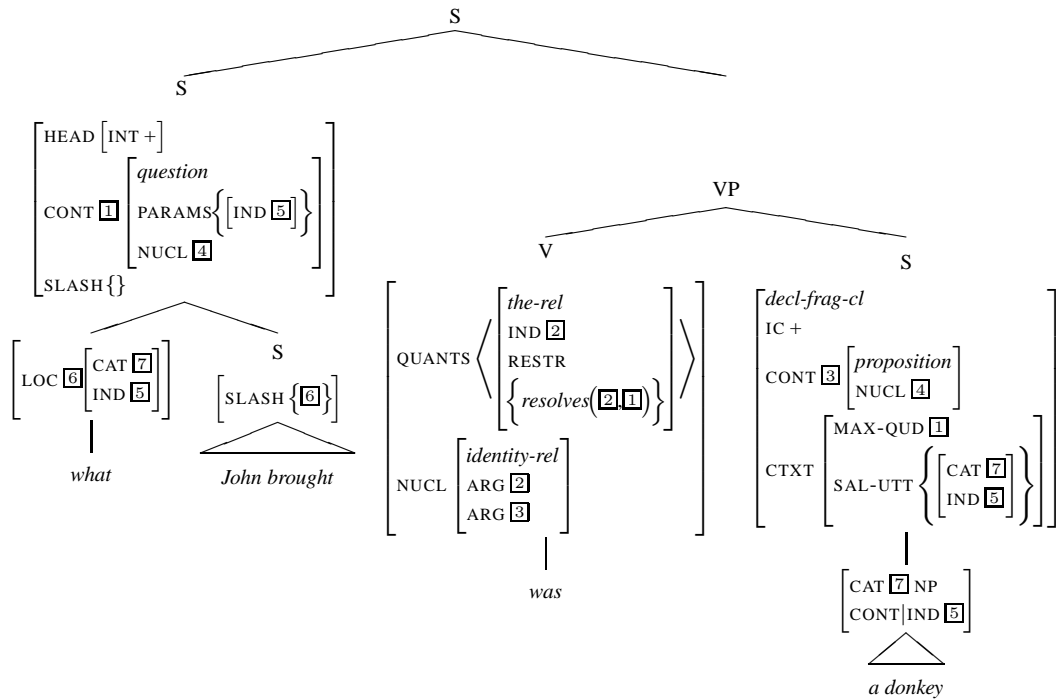

([4] = brought([8],[5]))

In (36), since the SAL-UTT value contains the category value of the initial *wh*-phrase, the category identity between the pivot and the initial *wh*-phrase can be accounted for.

4.3 On the interrogative analysis of SPC *wh*-clauses

In section 3.2, we have seen limited usage of *wh*-phrases and anti-pied-piping property of SPCs. In order to account for the restricted occurrence of interrogative *wh*-clauses in SPCs, I make a couple of assumptions. First, nouns, determiners, and adverbs are assumed to have an additional head feature INT, whose value of *wh*-interrogative words (e.g., *who*, *what*, *which*, *where*, and *how*) is [INT +]. Second, a new type of clause *p(seudo)c(left)-cl(ause)* is introduced as a subtype of *wh-int-cl*.

(37) *wh*-words in interrogatives:

$$\left[\text{HEAD} \left[\text{INT} + \right] \right]$$

(38) *p(seudo)c(left)-cl(ause)* (a subtype of *wh-int-cl*):

$$\left[\text{HEAD} \left[\text{INT} \boxed{\mathbb{1}} \right] \right] \rightarrow \left[\text{HEAD} \left[\text{INT} \boxed{\mathbb{1}} \right] \right], \mathbf{H}$$

I propose the constraint (38) for the type *p(seudo)-c(left)-cl(ause)*. Since *pc-cl* is a subtype of *wh-int-cl*, it obeys Ginzburg & Sag's constraints imposed on the types *inter-cl* and *wh-int-cl*.

(39) Interrogative Retrieval Constraint (Ginzburg & Sag 2000:227)

inter-cl:

$$\left[\begin{array}{l} \text{STORE} \boxed{\Sigma_1} \\ \text{CONT} \left[\text{PARAMS} \boxed{\Sigma_2} \right] \end{array} \right] \rightarrow \dots \mathbf{H} \left[\text{STORE} \boxed{\Sigma_1} \uplus \boxed{\Sigma_2} \right] \dots$$

(40) Filler Inclusion Constraint (Ginzburg & Sag 2000:228)

wh-int-cl:

$$\left[\text{CONT} \left[\text{PARAMS} \left\{ \boxed{\mathbb{1}} \right\} \uplus \text{set} \right] \right] \rightarrow \left[\text{WH} \left\{ \boxed{\mathbb{1}} \right\} \right], \mathbf{H}$$

Now let's look at how this can account for no pied-piping effects. As the lexical description of *be* in (27) specifies, the precopular clause is required to be [INT+]. Since the INT is a head feature, in an ordinary phrase, it is inherited from the head, not from a specifier or complement daughter. Consequently, by the Generalized Head Feature Principle in (41), the bracketed phrases in (42) is [INT-], thus not permitted as a precopular clause by (27).

(41) Generalized Head Feature Principle

hd-ph:

$$\left[\text{SYNSEM} / \boxed{\mathbb{1}} \right] \rightarrow \dots \mathbf{H} \left[\text{SYNSEM} / \boxed{\mathbb{1}} \right] \dots$$

- (42) a. *[[Which student] the teacher visited] was Jane.
 b. *[[About what] the student asked] was about music.

Therefore, it is explained why *wh*-clauses with *wh*-determiners cannot appear as in (17) and why pied-piped PP is not allowed as in (19).

In a *pc-cl*, the INT value is inherited from the filler daughter by (38), which involves non-default inheritance of HEAD information.⁷ Accordingly, the bracketed *wh*-clause in (43) is [INT +], obeying the relevant description in (27).

- (43) [[What] Jane found] was a pebble.

So far our analysis has assumed that nominal *wh*-words in (16), i.e., *who*, *where*, *how*, and *why* are all basically available in SPCs. On the other hand, for the speakers who do not accept (part of) the examples in (16), the current analysis can be slightly modified: we can posit a head feature PC (PSEUDOCLEFT) instead of INT, and lexically mark the *wh*-words as either [PC +] or [PC -], depending on their availability in pseudocleft constructions. Thus for instance, for speakers not accepting examples with *why*, e.g., (16d), *why* can be marked [PC -]. If this line of analysis is necessitated, the INT feature in (27) and (38) will have to be accordingly replaced by the PC feature.

5 Some remarks on connectivity effects

In this final section, I will briefly discuss the connectivity effects. Since my account is based on Ginzburg & Sag's analysis short answers, connectivity should be handled via the account of short answers. Although I think that there are a lot more work to be done, I'll sketch some possible accounts and remaining issues.

5.1 Possible accounts

First, as shown in (45), which analyzes the pivot of (44), bound variable readings in SPCs can be represented in the CONTENT of the pivot. In (45), the QUANTS and STORE values of the fragment clause are constrained by (35). More specifically, the two quantifiers in the QUANTS list come from the QUANTS of the question in the MAX-QUD and the head daughter's STORE value. The other order of the quantifiers in which the universal quantifier takes narrow scope is prohibited, because it yields an unbound variable in its interpretation.⁸

⁷Such non-default inheritance of certain HEAD information may occur in free relative constructions as well.

(i) [_{NP} [_{NP} Whomever]_{acc} he likes]_{nom} makes a big trouble. (Lee 2002:35)

⁸Alternatively, bound variable connectivity can be handled by Ginzburg & Sag's account of functional uses of *wh*-phrases and QPs.

(44) What everyone_i proved was his_i theory.

(45)

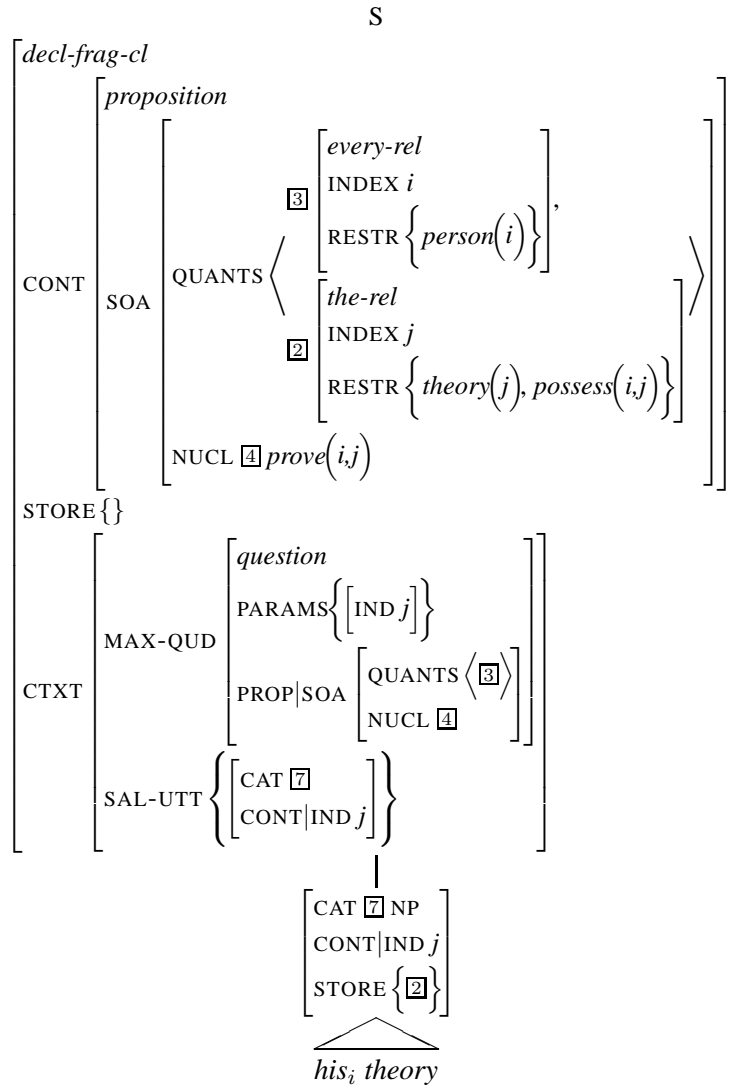

As for NPI connectivity, following Ladusaw (1979), we can make a simple assumption that *any* is an indefinite that is required to appear within the scope of a downward entailing operator in its interpretation (Sharvit 1999:310). If we allow negation to be represented by a negative quantifier, as in Ginzburg & Sag (2000:335), the CONT of the pivot phrase in (2b) can be described as in (47). In the following, (2b) is repeated as (46).

nomena, etc. If our analysis is on the right track, then binding principle connectivity should be handled via the analysis of short answers.

Another issue is how to account for anti-connectivity effects in (25) and (26). This also directly depend on the account of anti-connectivity in question-short-answer pairs. In (26), the quantifier originating from the pivot takes only narrow scope with respect to the quantifiers in the *wh*-clause, and this can be guaranteed by specifying a fixed order of quantifier scope in the type constraints of *decl-frag-cl*. However, it has to be looked at more carefully whether this kind of scope relation can be generalized in question-short-answer pairs and SPCs. I leave this issue for future research.

References

- [1] Akmajian, A. 1970. On deriving cleft sentences from pseudo-cleft sentences, *Linguistic Inquiry* 1, 149-168.
- [2] Boškovič Ž. 1997. Pseudoclefts. *Studia Linguistica* 51, 235-277.
- [3] Cecchetto, C. 2000. Connectivity and anti-connectivity in pseudoclefts. *NELS* 30, 137-151.
- [4] Cecchetto, C. 2001. Syntactic or semantic reconstruction? Evidence from pseudoclefts and clitic left dislocation. In *Semantic Interfaces*, eds. Cecchetto et al., 90-144. CSLI Publications.
- [5] Chierchia, G. 1993. Questions with quantifiers. *Natural Language Semantics* 1, 181-234.
- [6] Den Dikken, M, A. Meinunger, & C. Wilder. 2000. Pseudoclefts and ellipsis. *Studia Linguistica* 54, 41-89.
- [7] Hankamer, J. 1974. On the nature of *wh*-clefting. *Chicago Linguistic Society* 10. 221-286.
- [8] Heycock & Kroch. 1999. Pseudocleft connectedness: Implications for the LF interface level. *Linguistic Inquiry* 30, 365-397.
- [9] Heycock & Kroch. 2002. Topic, Focus, and Syntactic Representations. *WCCFL* 21, 101-125.
- [10] Ginzburg, J. & I.A. Sag. 2000. *Interrogative Investigation*. CSLI Publications.
- [11] Higgins, F.R. 1979. *The Pseudo-Cleft Construction in English*. Garland Press.
- [12] Jacobson, P. 1994. Binding connectivity in copular sentences. *SALT IV*, 161-178.
- [13] Ladusaw, W. 1979. *Polarity Sensitivity as Inherent Scope Relations*. PhD dissertation, University of Texas, Austin.
- [14] Lee, H. 2002. *English Free Relative Constuctions*. MA thesis, Seoul National University.
- [15] Meinunger, A. 1998. A monoclausal structure for (pseudo-)cleft sentences. *NELS* 28, 283-298.

- [16] Partee, B. 1986. Ambiguous pseudoclefts with unambiguous BE. *NELS* 16, 354-366.
- [17] Ross, H. 1985. The source of pseudocleft sentences. Handout of talk given at New York University, November 1985.
- [18] Ross, H. 1997. That is the question, paper presented at the University of Pennsylvania.
- [19] Ross, J.R. 1972. Act. In *Semantics of Natural Language*, eds., Davison et al., 70-126. Reidel.
- [20] Sag, I.A. & T. Wasow. 1999. *Syntactic Theory. A Formal Introduction*. CSLI Publications.
- [21] Schlenker, P. 1998. Pseudocleft connectivity and the structure of noun phrases. Ms., MIT.
- [22] Schlenker, P. 2003. Clausal Equations (A Note on the Connectivity Problem). *Natural Language and Linguistic Theory* 21, 157-214.
- [23] Sharvit, Y. 1999. Connectivity in specificational sentences. *Natural Language Semantics* 7, 299-339.
- [24] Van Eynde, F. 2000. A constraint-based semantics for tenses and temporal auxiliaries. In *Grammatical Interfaces in HPSG*, eds., Cann et al., 231-249. CSLI Publications.