

**Proceedings of the 11th International Conference on
Head-Driven Phrase Structure Grammar**

Center for Computational Linguistics, Katholieke Universiteit
Leuven

Stefan Müller (Editor)

2004

Stanford, CA: CSLI Publications

The papers are published under a CC-BY license:
<http://creativecommons.org/licenses/by/4.0/>

Contents

Editor's note	4
I Contributions to the Main Conference	5
Anne Abeillé, Olivier Bonami, Danièle Godard, Jesse Tseng: The syntax of French N' phrases	6
Doug Arnold: Non-restrictive relative clauses in Construction Based HPSG	27
John Beavers, Ivan A. Sag: Coordinate ellipsis and apparent non-constituent coordination	48
Robert D. Borsley: An approach to English comparative correlatives	70
Michael W. Daniels, W. Detmar Meurers: GIDL P: A grammar format for linearization-based HPSG	93
Henriette de Swart: A typology of negation in a constraint-based framework of syntax and semantics	112
Markus Egg: Mismatches at the syntax-semantics interface	119
Jean-Pierre Koenig, Anthony R. Davis: Raising doubts about Russian impersonals	140
Valia Kordoni: Between shifts and alternations: Ditransitive constructions	151
Takafumi Maekawa: Constituency, word order and focus projection	168
Ian Marshall, Eva Safar: Sign language generation in an ALE HPSG	189
Stefan Müller: An analysis of depictive secondary predicates in German without discontinuous constituents	202
Manfred Sailer: Propositional relative clauses in German	223
Melanie Siegel, Emily M. Bender: Head-initial constructions in Japanese	244
Jan-Philipp Soehn: License to COLL: How to bind bound words and readings to their contexts	261
Mehran A. Taghvaipour: An HPSG analysis of Persian relative clauses	274
Beata Trawinski: Towards licensing of adverbial noun phrases in HPSG	294

Frank Van Eynde: Pied piping is a local dependency	313
Shûichi Yatabe: A comprehensive theory of coordination of unlikes	335
II Contributions to the Workshop	356
Dorothee Beermann, Lars Hellan: A treatment of directionals in two implemented HPSG grammars	357
Berthold Crysmann: Underspecification of intersective modifier attachment: Some arguments from German	378
Anette Frank, Kathrin Spreyer, Witold Drozdzyński, Hans-Ulrich Krieger, Ulrich Schäfer: Constraint-based RMRS construction from shallow grammars	393
Petter Haugereid: Linking in constructions	414
Gerald Penn, Frank Richter: Lexical Resource Semantics: From theory to implementation	423
Anders Søgaard: A compound matrix	444

Editor's note

The 11th International Conference on Head-Driven Phrase Structure Grammar (2004) was held at the Center for Computational Linguistics, Katholieke Universiteit Leuven in Belgium.

The conference featured 3 invited talks, 20 papers, and 1 alternate paper, selected by the program committee (Gosse Bouma, Jonathan Ginzburg, Jong-Bok Kim, Tibor Kiss, Kordula de Kuthy, Bob Levine, Rob Malouf, Philip Miller, Paola Monachesi, Stefan Müller, John Nerbonne, Ivan Sag, Manfred Sailer, Frank Van Eynde, Eun-Jung Yoo, Kei Yoshimoto). A workshop on *Semantics in Grammar Engineering* was attached to the conference. It featured one invited talk and 7 papers, selected by the workshop program committee (Dorothee Beermann, Ash Asudeh, Mary Dalrymple, Markus Egg, Lars Hellan, Jean-Pierre Koenig, Valia Kordoni, Manfred Sailer).

In total there were 32 submissions to the main conference and 7 submissions to the workshop. We want to thank the respective program committees for putting this nice program together.

Thanks go to Frank van Eynde, who was in charge of local arrangements.

As in the past years the contributions to the conference proceedings are based on the five page abstract that was reviewed by the respective program committees, but there is no additional reviewing of the longer contribution to the proceedings. To ensure easy access and fast publication we have chosen an electronic format.

The proceedings include all the papers except those by Farrell Ackerman, Irina Nikolaeva, and Rob Malouf, Ann Copestake, Liv Ellingsen, Jonathan Ginzburg, Tibor Kiss, and Adam Przepiórkowski and Alexandr Rosen.

Part I

Contributions to the Main Conference

The syntax of French N' phrases

Anne Abeillé 

Universite Paris 7

Olivier Bonami 

Universite Paris 7

Danièle Godard 

Universite Paris 7

Jesse Tseng

Universite Paris 7

Proceedings of the 11th International Conference on
Head-Driven Phrase Structure Grammar

Center for Computational Linguistics, Katholieke Universiteit Leuven

Stefan Müller (Editor)

2004

Stanford, CA: CSLI Publications

pages 6–26

Abeillé, Anne, Olivier Bonami, Danièle Godard & Jesse Tseng. 2004. The syntax of French N' phrases. In Stefan Müller (ed.), *Proceedings of the 11th International Conference on Head-Driven Phrase Structure Grammar*, Center for Computational Linguistics, Katholieke Universiteit Leuven, 6–26. Stanford, CA: CSLI Publications. DOI: 10.21248/hpsg.2004.1. 

Abstract

Of all French functional elements, the form *de* has without question the widest variety of uses, and presents the greatest challenge for linguistic description and analysis. Historically a preposition, it still has a number of prepositional uses in modern French, but in many contexts it calls for an altogether different treatment. We begin by outlining a general distinction between “oblique” and “non-oblique” uses of *de*. We then develop a detailed account of constructions where *de* combines with an N' . We provide a unitary analysis of *de* in three constructions (quantifier extraction, “quantification at a distance”, and negative contexts) which have been not been considered to be related in previous accounts.

The aim of this article is to present a novel and unified analysis of structures of the form [*de* N'] in French. After giving an overview of the uses of the element *de* and establishing a partition of these uses corresponding to two distinct syntactic analyses for *de* (section 1), we provide a detailed description of the *de*- N' structures examined in the rest of the paper (section 2). Section 3 presents arguments for treating certain *de*- N' phrases as extraction sites, and section 4 provides the full HPSG analysis, with example structures.

1 Background: The dual syntactic nature of *de*

This section briefly motivates a two-way classification of the uses of *de* based on a number of syntactic criteria, and presents an HPSG account of the data. For a more complete presentation (including similar results for the element *à*), see Abeillé et al. (2003).¹

1.1 Oblique vs. non-oblique uses

First we can identify “oblique” uses of *de*, characterized by the following properties: nothing can be extracted from the phrase that *de* combines with (1), *de* can combine with a coordination of phrases (2), and the *de*-phrase cannot appear in subject position (3).

- (1) Je me souviens [de la fin de ce film].
'I remember the end of that film.'

↪ *un film dont je me souviens [de la fin ____]
'a film of which I remember the ending'

- (2) J'ai besoin [de [cette farine et cette levure]] .
'I need this flour and this yeast.'

[†]We would like to thank the participants of the group “Grammaire typologique des formes faibles” at Paris 7 University, in particular Denis Creissels and Anne Zribi-Hertz, and the audience of the HPSG Conference in Leuven, in particular Henriëtte de Swart and Frank Van Eynde, for their valuable comments on earlier presentations of this work.

¹Kupferman (2004) presents a related approach to partitioning the uses of *de*.

- (3) *[De mort] est la seule façon efficace de menacer ces gens.
 ‘With death is the only effective way to threaten these people.’

Using these tests, we find that oblique *de* appears in combination with NP and N’ (as in the preceding examples), and also with PP, AP, and AdvP (but never with VP):

- (4) a. Il surgit [de derrière le rideau].
 ‘He jumped out from behind the curtain.’
 b. quelque chose [de plus traditionnel]
 ‘something more traditional’
 c. deux jours [de plus]
 ‘two days more’

In “non-oblique” uses, *de* behaves very differently, allowing extraction out of its sister phrase (5), not taking wide scope over a coordination of phrases (6), and sometimes occurring in subject position (7).

- (5) a. Je n’ai pas lu [de livres de cet auteur].
 ‘I haven’t read any books by this author.’
 ~> un auteur dont je n’ai pas lu [de livres____]
 ‘an author of whom I haven’t read any books’
 b. Je ne me souviens pas [d’avoir lu ce livre].
 ‘I don’t remember having read that book.’
 ~> un livre que je ne me souviens pas [d’avoir lu____]
 ‘a book I don’t remember having read’
 (6) *On nous a apporté plein [de [pain et vin]] .
 ‘They brought us loads of bread and wine.’
 (7) [De sortir un peu] te ferait du bien.
 ‘Getting out a bit would do you some good.’

In addition to these examples containing N’ and infinitival VP, non-oblique *de* also combines with the definite article to give rise to the so-called “partitive article” (8a). This construction is in fact available with other demonstrative and possessive specifiers as well (8b) (Kupferman, 2004).

- (8) a. un courrier contenant [de la poudre blanche suspecte]
 ‘a letter containing suspicious white powder’
 b. acheter [de ce/son whisky]
 ‘buy some of that/his kind of whisky’

1.2 Analysis

The properties of oblique *de*-phrases can be accounted for in a straightforward manner if we analyze *de* as an ordinary preposition, satisfying the lexical description in (9). In French, PPs are extraction islands, hence the empty SLASH list for

all *prep-words* (10b).² And unlike their English counterparts, French PPs cannot be used as subjects (3,11).

(9) prepositional *de*: *prep-word* &

$$\left[\begin{array}{ll} \text{MARKING} & de \\ \text{COMPS} & \left\langle \left[\begin{array}{ll} \text{HEAD} & \neg verb \\ \text{COMPS} & \langle \rangle \end{array} \right] \right\rangle \end{array} \right]$$

(10) a. *une loi dont j’ai voté pour l’auteur
 ‘a law of which I voted for the author (whose author I voted for)’

b. $prep\text{-}word \rightarrow \left[\begin{array}{ll} \text{HEAD} & prep \\ \text{MARKING} & marked \\ \text{SLASH} & \{ \} \end{array} \right]$

(11) *Sous la table est une bonne cachette.
 ‘Under the table is a good hiding place.’

Non-oblique *de*-phrases, on the other hand, do not behave like PPs, but more like NPs or VPs. We propose that non-oblique *de* is a “weak head”—that is, a syntactic head that shares its HEAD value with its complement (Tseng, 2002). One lexical entry for the weak head *de*, used with nominal and verbal complements, is shown in Figure 1.

$$\left[\begin{array}{ll} \text{HEAD} & \boxed{1} \\ \text{MARKING} & de \\ \text{SUBJ} & \boxed{2} \\ \text{SPR} & \boxed{3} \\ \text{COMPS} & \left\langle \left[\begin{array}{ll} \text{HEAD} & \boxed{1} \\ \text{MARKING} & unmarked \\ \text{SUBJ} & \boxed{2} \\ \text{SPR} & \boxed{3} \\ \text{COMPS} & \langle \rangle \\ \text{CONT} & \boxed{4} \end{array} \right] \right\rangle \\ \text{CONT} & \boxed{4} \end{array} \right]$$

Figure 1: Weak head *de* #1

As an example, if the weak head *de* selects a verbal complement as in (7), the resulting [*de* VP] combination has the HEAD value [*verb*, VFORM *inf*] and

²This observation holds for standard varieties of European French. In other varieties, the constraint can be relaxed in certain contexts.

we expect it to have the properties of an infinitival VP with respect to distribution, extraction, and so on. In this case, *de* will also inherit the non-empty SUBJ list of its VP complement, which will then be visible on the dominating phrase (crucial for the analysis of raising and control). Note that in our analysis, all [*de* VP] structures involve the weak head of Figure 1, and never the preposition in (9):³

On the other hand, if the weak head *de* combines with a nominal complement as in *plein de pain* (6), the resulting [*de* NP] combination is correctly predicted to have the grammatical properties of an NP. Note that for “partitive” NPs as in (8), a distinct weak head entry for *de* is required, one that selects an NP complement introduced by a definite, demonstrative, or possessive specifier, and contributes the appropriate partitive/indefinite semantics.

Oblique and non-oblique *de* do share one crucial property: the MARKING value *de*, which then propagates to the phrases they project. This explains why all pronominalizable *de*-phrases alternate with the clitic *en*, despite their otherwise highly divergent grammatical properties (12). The principles governing *en*-cliticization refer only to the feature [MARKING *de*].

- (12) a. Je me souviens [de ce film]. (*oblique*)
 ‘I remember that film.’
 ↪ Je m’en souviens. ‘I remember it.’
 b. Je n’ai pas lu [de livres]. (*non-oblique*)
 ‘I haven’t read any books.’
 ↪ Je n’en ai pas lu. ‘I haven’t read any.’

The MARKING feature is also used to prevent iteration of the weak head *de*. As indicated in Figure 1, its complement must be *unmarked*, and so cannot already be a projection of *de*. Another consequence of the *unmarked* constraint is that the weak head cannot select a prepositional complement, because all prepositions introduce a *marked* specification, as shown in (10b). Prepositional *de* (9), on the other hand, can take a *marked* PP complement, as in (4a), or even a [MARKING *de*] complement headed by the weak head *de*:⁴

- (13) J’ai besoin de [beaucoup de farine].
 ‘I need a lot of flour.’

³This is in contrast, for example, to Huot 1981, who proposes either a PP or a VP analysis depending on the higher verb.

⁴See section 4.1 for details of the analysis of the bracketed *de*-phrase. Note that prepositional *de* cannot be immediately followed by another *de*:

- (i) *J’ai besoin de [de la farine].
 ‘I need (some) flour.’
 (ii) J’ai besoin de farine.

A full account of these “cacophony” effects (Gross, 1967) prohibiting adjacent occurrences of *de* must incorporate constraints referring to linear word order (e.g., the notion of “left edge”). The grammatical alternative to (i) is the so-called “haplology” construction (ii) with a single occurrence of *de* (and no definite article). A special prepositional entry for *de*, selecting an *N'* complement (with the appropriate semantics), is required for such examples.

De also displays some morphophonological idiosyncrasies: it always undergoes vowel elision ($de \rightsquigarrow d'$) conditioned by the following context, and contraction with the specifier forms *le* and *les* (giving rise to *du* and *des* respectively). The oblique vs. non-oblique status of *de* has no influence on its morphophonological behavior. Finally, we note that the partition into prepositional (oblique) and weak head (non-oblique) uses proposed here does not correlate with any semantic criteria. In particular, there are semantically empty prepositional uses of *de* and semantically potent weak head uses.

2 Nominal *de*-phrases

In the remainder of this paper, we focus on the various types of (non-oblique) nominal phrases of the form $de-N'$, which have restricted distribution and must always be licensed by other material. In (14), for instance, the *de*-phrase is not licensed, and the sentence is ungrammatical.

- (14) *J'ai lu [de livres].
'I read DE books.'

There are several ways in which example (14) can be extended to produce a grammatical sentence.⁵

2.1 Local quantification

In the simplest case, $de-N'$ can be licensed locally by a degree expression from a class including adverbs (*beaucoup*, *infiniment*, *combien*), nouns (*nombre*, *quantité*), or the invariable form *plein*. The resulting phrases of the form [Deg *de* *N'*] (e.g., *beaucoup de livres* 'a lot of books') have the distributional properties of ordinary NPs: they can appear as subject or complement of a verb, or as complement of a preposition.

- (15) a. Nous avons perdu [beaucoup de livres].
'We lost a lot of books.'
b. [Beaucoup de livres] ont été abîmés.
'A lot of books were damaged.'

⁵Cases not considered here include:

- (i) *de* as allomorphic variant of partitive *des* before pre-nominal modifier
J'ai lu [de très vieux livres].
'I read some very old books.'
- (ii) dislocated $de-N'$ (Milner, 1978)
J'en veux trois, de robes.
'I want three dresses.'
- (iii) rare occurrence in some negative polarity contexts (Gaatone, 1971, 1992; Muller, 1997)
A-t-on jamais publié de livre aussi mauvais ?
'Has such a bad book ever been published?'

- c. Il est parti avec [beaucoup de livres].
 ‘He left with a lot of books.’

Semantically, we have a mass/plural nominal expression with the degree element functioning as an intersective quantifier. For example, in *lire beaucoup de livres*, the quantity of books read is measured against some contextually determined scale and found to be ‘a lot’.

Note that a complete analysis of degree adverbs should be able to relate this use to occurrences of the same adverbs as verb modifiers—see (17a) below, for example. Abeillé and Godard (2003) propose treating degree adverbs uniformly as modifiers, even in the [Deg *de* N'] construction. While such an analysis is intuitively appealing, it faces problems at the syntax-semantics interface: [Deg *de* N'] has scopal properties typical of a quantified NP, as illustrated by the interaction with negation in (16). Thus the degree expression in [Deg *de* N'] does not behave semantically like a noun modifier, but more like a specifier.

- (16) a. Paul n’a pas emprunté beaucoup de livres.
 Most salient reading: ‘It is not the case that Paul borrowed a large number of books.’ (NEG > *beaucoup*)
- b. Beaucoup de livres n’ont pas été empruntés par Paul.
 Most salient reading: ‘There is a large number of books *x* such that it is not the case that Paul borrowed *x*.’ (*beaucoup* > NEG)

A more adequate way to relate the ad-verbal and ad-nominal uses is to assume that the relation between an entity and a scale associated with a degree expression is used to form an intersective modifier in the ad-verbal use, and to specify the size of the group which is also quantified over in the [Deg *de* N'] construction. In the semantic forms below, *S* represents a contextually-supplied standard degree scale.

- (17) a. Paul a beaucoup dormi.
 ‘Paul slept a lot.’
 $\exists e[\text{sleep}(e, p) \wedge \text{a-lot}(e, S)]$
- b. Beaucoup d’enfants dorment.
 ‘Many children are sleeping.’
 $\exists e \exists X[\text{children}(X) \wedge \text{sleep}(e, X) \wedge \text{a-lot}(X, S)]$

For the sake of brevity, we will treat the degree elements in [Deg *de* N'] phrases as atomic binary quantifiers.

2.2 Non-adjacent quantifier

There are two variants of *de-N'* licensed by degree quantification in which the degree element does not form a constituent with the *de-N'* phrase.

First, the licensing adverbial can be the filler in a filler-gap construction: either the interrogative *wh*-word *combien* ‘how much/how many’ (18a), or correlative

plus, moins ‘more, less’.⁶

(18) Quantifier extraction

- a. Combien as-tu lu [___ de livres en latin] ?
how many have you read DE books in Latin
‘How many books have you read in Latin?’
- b. Plus Paul veut lire [___ de livres], plus il va à la
more Paul wants read DE books more he goes to the
bibliothèque.
library
‘The more Paul wants to read books, the more he goes to the library.’

The split *combien ... de-N'* construction contrasts with interrogatives containing the NP [*combien de N'*], either in situ or in filler position:

- (19) a. Tu as lu [combien de livres en latin] ?
‘You’ve read how many books in Latin?’
- b. [Combien de livres en latin] as-tu lus ?
‘How many books in Latin have you read?’

Second, a subset of the degree expressions found in [Deg *de N'*] structures (*beaucoup, trop, assez, ...*) can “float” immediately to the left of an infinitive or past participle, giving rise to “quantification at a distance” (henceforth QAD).

- (20) Il va [beaucoup lire [de livres]] / Il a [beaucoup lu [de livres]].
he goes MANY read DE books / he has MANY read DE books
‘He’s going to read many books / He has read many books.’

In fact the degree adverb cannot be arbitrarily distant from the *de-N'* phrase it licenses; QAD is VP-bounded (21).

- (21) Paul m’a forcé [_{VP} à boire [beaucoup de pastis]] .
‘Paul forced me to drink a lot of pastis’
↪ *Paul m’a beaucoup forcé [_{VP} à boire [de pastis]] .

In contrast to the ambiguity observed for [Deg *de N'*] phrases (22a)⁷ the adverb in QAD systematically takes narrow scope (22b).

- (22) a. Paul recevra chaque étudiant qui a lu [beaucoup de livres]. (local Q, two readings)
 - (i) ‘Paul will meet every student who read a large number of books’ *or*
 - (ii) ‘There is a large number of books *x* such that Paul will meet every student who read *x*’

⁶See Borsley, 2004 for arguments in favor of treating correlative constructions as filler-gap structures.

⁷Recall also the the examples in (16). It should be noted that the wide scope reading (ii) in (22a) is not accepted by all speakers.

- b. Paul recevra chaque étudiant qui a beaucoup lu [de livres]. (QAD, reading (i) only)

Moreover, QAD is not semantically compatible with all predicates (23). According to Obenauer (1994) and Doetjes (1997), this indicates that the adverb quantifies over the predicate, and only indirectly over the nominal argument.

- (23) a. Jean a vu / apprécié [beaucoup de films]. (local Q)
 ‘Jean has seen/appreciated many films’
 b. Jean a beaucoup vu / ??apprécié [de films]. (QAD)

The data are quite tricky, however, and it is unclear how this general proposal can be implemented in a fully explicit semantics. For the purposes of this paper we treat QAD as quantification over individuals.

2.3 Negative contexts

Finally, *de-N'* phrases can be licensed by negation:⁸

- (24) Paul n’a pas lu [de livre].
 ‘Paul did not read any book.’

In such cases *de-N'* is interpreted as an existential quantifier in the immediate scope of the negation. This is in contrast to the ambiguity of example (25) involving the indefinite article *un*; sentence (24) has only the interpretation (i).

- (25) Paul n’a pas lu un livre.
 (i) ‘Paul read no book.’
 (ii) ‘There is a book that Paul didn’t read.’

There are a number of non-verbal negative licensers, including the preposition *sans* ‘without’ + VP[*inf*] (26), and left-adjoined negative adverbs (27):⁹

- (26) Il est parti sans donner [d’explications].
 ‘He left without giving any explanations.’
 (27) a. Pas [de problème] !
 ‘No problem!’
 b. Paul préfère une mauvaise solution à pas [de solution] du tout.
 ‘Paul prefers a bad solution to no solution at all.’

⁸The noun can be singular or plural, with no change in meaning.

(i) Je n’ai pas lu de journal / de journaux.
 ‘I did not read any newspaper / newspapers.’

⁹The preposition *sans* cannot license a *de-N'* phrase as its own complement; in this case, it takes a bare (*unmarked*) *N'* complement:

(i) Il est parti sans explications/*[d’explications].
 ‘He left without explanations.’

3 Autonomous *de-N'* phrases as extraction sites

We propose a unified treatment of “autonomous” *de-N'* phrases—that is, those that do not form a NP constituent with their licenser (an extracted quantifier, a QAD adverb, or negation).¹⁰ Our approach is motivated by the following observations.

3.1 Distribution

The *de-N'* can be a direct object (see examples (18), (20), and (24)), but never a pre-verbal subject or complement of a preposition (28–29). With quantifier extraction and negation, *de-N'* phrases can also be licensed in post-verbal (inverted) subject position (30).

- (28) a. *Combien dis-tu que [de clients] sont venus ?
'How many clients do you say came?'
b. *[De clients] sont beaucoup venus ce matin.
'Many clients came this morning.'
c. *[D'enfants] ne vont pas là-bas.
'No children go there.'
- (29) a. *Combien as-tu voté [_{PP} contre [de projets]] ?
'How many projects did you vote against?'
b. *Paul a beaucoup voté [_{PP} contre [de projets]] .
'Paul has voted against many projects.'
c. *Paul n'a jamais voté [_{PP} contre [de projet]] .
'Paul never voted against any project.'
- (30) a. Combien dis-tu que sont venus [de clients] ?
'How many clients do you say came?'
b. *un jour où sont beaucoup venus [de clients]
'a day when many clients came'
c. un endroit où ne vont pas [d'enfants]
'a place where no children go'

3.2 Unbounded dependency

Extracted quantifiers and negative licensers can be arbitrarily distant from the *de-N'* phrase:

- (31) a. Combien Paul voulait-il [que Marie lise [de livres]] ?
'How many books did Paul want Marie to read?'
b. Paul ne voulait pas [que Marie lise [de livres]].
'Paul did not want Marie to read books.'

QAD, on the other hand, is bounded, as we saw in (21).

¹⁰See Kayne (1981) for an early proposal along similar lines.

3.3 Island constraints

Quantifier extraction and, more surprisingly, licensing by negation obey the PP island constraint (29), the complex NP constraint (32), and the subject constraint (33). We show no results for QAD, which obeys these constraints vacuously, since all of the relevant contexts are already excluded by VP-boundedness.

- (32) a. *Combien connais-tu un scientifique [qui a [d'idées sur ce sujet]] ?
'You know a scientist who has how many ideas on this topic?'
- b. *Je ne connais pas un scientifique [qui ait [d'idées sur ce sujet]].
'I don't know a scientist who has any ideas on this topic.'
- (33) a. *Combien dis-tu que [lire [de livres]] t'a plu ?
'You say that reading how many books pleased you?'
- b. *[Que Paul ait lu [de livre]] ne m'a pas surpris.
'That Paul read a book did not surprise me.'

3.4 Coordinate structure constraint

Here, the results are less clear, with the CSC strictly enforced in quantifier extraction structures (34), but less so in cases of QAD (35) and negation (36).

- (34) a. Combien as-tu [lu de livres] et [feuilleté de magazines] ?
'How many books have you read and how many magazines have you leafed through?'
- b. *Combien as-tu [lu de livres] et [feuilleté un magazine] ?
'How many books have you read and leafed through a magazine?'
- (35) a. Paul a trop mangé [de pizza] et [de glace].
'Paul has eaten too much pizza and ice cream.'
- b. *Paul a trop mangé [de pizza] et [trois glaces].
'Paul has eaten too much pizza and two ice creams.'
- c. ?Paul a trop mangé de pizzas et ce genre de glace.
'Paul has eaten pizza, and this type of ice cream, on too many occasions.'
- (36) a. Paul n'a pas mangé de gâteau ou de cerises.
'Paul ate neither cake nor cherries.'
- b. *Paul n'a pas mangé de gâteau ou la pomme.
'Paul ate neither a piece of the cake nor the apple.'
- c. Paul ne veut pas écouter [de disque de Johnny] ou regarder [de film avec lui].
'Paul wants neither to listen to one of J's albums nor to watch a movie with him in it.'
- d. ?Paul ne veut pas écouter [de disque de Johnny] ou aller au cinéma ce soir.

‘Paul wants neither to listen to one of J’s albums nor to go the movies tonight.’

In (35) we see that in QAD, the *de-N'* phrase can be coordinated with an ordinary NP if the “floating” degree adverb is interpreted as an iterative modifier on the second conjunct. For negation (36), direct coordination of a *de-N'* with an ordinary NP is impossible, but intervening VP projections can improve grammaticality.

3.5 Proposed approach

The data presented above lead us to make the following proposals:

- In quantifier extraction examples (e.g., involving *combien*), the *de-N'* introduces a SLASH dependency, terminated by the filler-head structure (as standardly assumed).
- In negative contexts also, *de-N'* introduces a SLASH dependency, that terminates at the node where the negation is retrieved.
- QAD is a more restricted phenomenon (not long-distance), but we can adopt the same basic syntax for the *de-N'* phrase (including the introduction of a SLASH element) in order to capture the constraints on its distribution.

The CSC facts are not necessarily problematic: the CSC has been argued to be not a general property of extraction, but a property of some filler-gap constructions, conditioned moreover by the discourse relation that links the conjuncts (Kehler, 2002, pp. 101–142). If so, it is not very surprising that the CSC does not apply to *de-N'* in negative contexts, which do involve SLASH dependencies, but are not filler-gap constructions.

4 An HPSG analysis of *de-N'*

In this section, where we present our formal analysis of *de-N'* licensing, we assume the theory of extraction, quantifier store, and interrogative constructions of Ginzburg and Sag (2001), and the approach to negation at the syntax-semantics interface of de Swart and Sag (2002).

4.1 The basic case: [Deg *de N'*]

Phrases in which *de-N'* is licensed by an immediately adjacent degree element, as in *beaucoup de livres*, are treated as ordinary head-specifier phrases, where the specifier is a quantificational degree expression (Milner, 1978). The relevant lexical entry for *beaucoup* is given in Figure 2. We propose a typical specifier entry, except that *beaucoup* selects (via SPEC) a category bearing the feature [MARKING *de*]. Consequently, *beaucoup* can only combine with an *N'* headed by the weak head *de*. This excludes **beaucoup livres*, even though *beaucoup* can be on the SPR

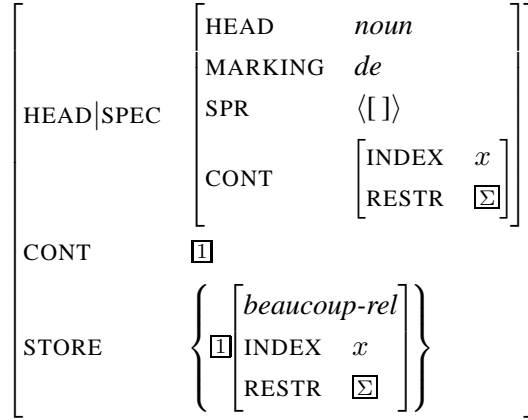

Figure 2: Lexical entry for *beaucoup* (specifier)

list of the common noun *livres*. The lexical entry of the weak head *de* in Figure 1 requires specifier-raising—e.g., the SPR requirement of *livres* becomes the SPR requirement of *de livres*. (Similarly, this entry requires subject-raising in the case of a VP[*inf*] complement.) The full analysis of the phrase *beaucoup de livres* can be seen in Figure 6 at the end of the paper.

4.2 *de-N'* and SLASH

As explained in section 3, we propose treating the licensing of autonomous *de-N'* phrases in terms of a SLASH dependency. We start by motivating a second lexical entry for the weak head *de*, distinct from the one in Figure 1.

We assume that the first argument of a common noun (i.e., its specifier) must be canonical (37). This accounts for the fact that specifiers of bare N's cannot be extracted (38).

$$(37) \quad cn-wd \rightarrow \left[\text{ARG-ST} \langle \textit{canon-ss} \rangle \oplus \textit{list}(\textit{synsem}) \right]$$

- (38) a. Quel livre as-tu lu ? ‘Which book did you read?’
b. *Quel as-tu lu livre ?

Given the SPR-list sharing indicated in the weak head entry in Figure 1, the combination of *de* and a common noun (e.g., *de livres*) always gives rise to a SPR-unsaturated nominal projection. We assume that such phrases are disallowed as the direct argument (subject or direct object) of a verb:¹¹

$$(39) \quad vb-wd \rightarrow \left[\text{ARG-ST} \textit{list} \left(\left[\text{SPR} \langle \rangle \right] \vee \left[\text{PRED} + \right] \right) \right]$$

¹¹This constraint does allow predicative nominal arguments to appear without a specifier, as in constructions like *devenir médecin* ‘become a doctor’ or *faire confiance* ‘trust’.

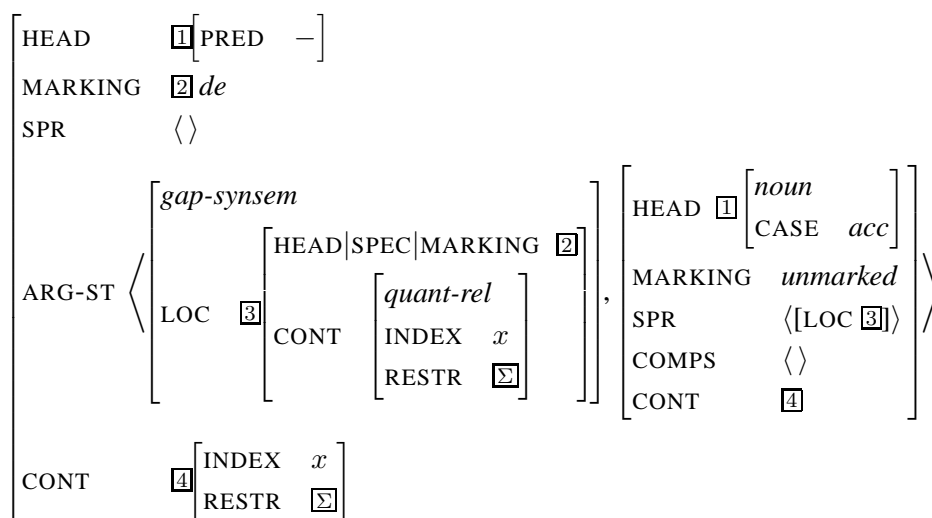

Figure 3: Weak head *de* #2, with slashed specifier

As a consequence of this constraint, a phrase like *de livres*, headed by the weak head in Figure 1, cannot be the direct argument of a verb (unless its SPR-requirement is satisfied by a degree expression like *beaucoup*).¹²

Those *de-N'* phrases that do occur autonomously must therefore be headed by a different weak head *de*, whose lexical entry is shown in Figure 3. The complement of this weak head (the second item on its ARG-ST list) is an unmarked, SPR-unsaturated nominal. Instead of inheriting the SPR requirement, like the weak head of Figure 1, this variant of *de* has an empty SPR list. This means that a phrase like *de livres*, headed by this weak head, can be used as a direct argument without violating constraint (39). The accusative case specification ensures that these *de-N'* phrases cannot be preverbal subjects¹³ or complements of a preposition (which bear *internal* case, Abeillé and Godard, 1999); recall the examples in (28–29) above. And the feature [PRED –] prevents the occurrence of predicative *de-N'* phrases in negative contexts.

(40) *Nous n'avons pas été [d'idiots]. 'We were no fools'

The most important aspect of the entry in Figure 3, however, is that the LOCAL value of the *N'* complement's unrealized specifier ends up in the SLASH set of *de* (as a result of SLASH Amalgamation applied to the ARG-ST list). The problem of licensing autonomous *de-N'* phrases thus becomes a matter of formulating the

¹²As it stands, the entry in Figure 1 allows *de* to combine with full NPs, incorrectly producing sentences like **Paul voit de Marie / de trois poissons* ('Paul sees DE Marie / DE three fish'). This can be excluded by further stating that the weak head must inherit a specifier (or a subject); more precisely, either SPR or SUBJ must be non-empty (but not both).

¹³They can appear as inverted subjects (30), which are accusative (Abeillé, 1997; Bonami et al., 1999).

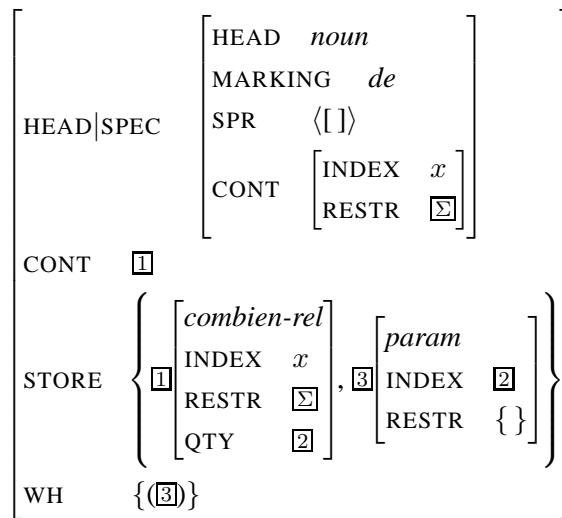

Figure 4: Lexical entry for *combien*

appropriate conditions for discharging the SLASH dependency introduced by the weak head. See Figure 7 at the end of the paper for the structure of the VP *lire de livres*; the SLASH set must somehow be emptied if this VP is to be part of a well-formed sentence.

4.3 Quantifier extraction

As an example of our treatment of quantifier extraction—see the data in (18)—we propose the lexical entry in Figure 4 for the specifier *combien*. This entry is syntactically similar to that of *beaucoup* in Figure 2, selecting an \bar{N} with the feature [MARKING *de*] via SPEC; after all, *combien* does appear in [Deg *de* \bar{N}] examples like (19), involving the first weak head *de* of Figure 1. In its semantic content, *combien* includes an extra argument for a quantity parameter, which is put on STORE, to be retrieved at the clause level and incorporated into a *question* semantic object (Ginzburg and Sag, 2001). Informally, this amounts to analyzing *Combien de livres a lus Paul ?* ‘How many books did Paul read?’ as asking for the number n such that Paul read n books.

In extraction constructions like (18a), where *combien* is split from the *de-N'* it licenses, the LOCAL value of *combien* is copied from the common noun’s SPR list into SLASH by the second weak head *de* of Figure 3. This SLASH element propagates to the clause level thanks to the standard NON-LOCAL feature principles (SLASH Amalgamation and Inheritance). At that point, *combien* is realized as the filler in a filler-head structure, binding off the element in SLASH (and thus licensing the *de-N'* phrase in which it originated).¹⁴

¹⁴In contrast, in examples like (19b) where the entire NP containing *combien* is extracted, the

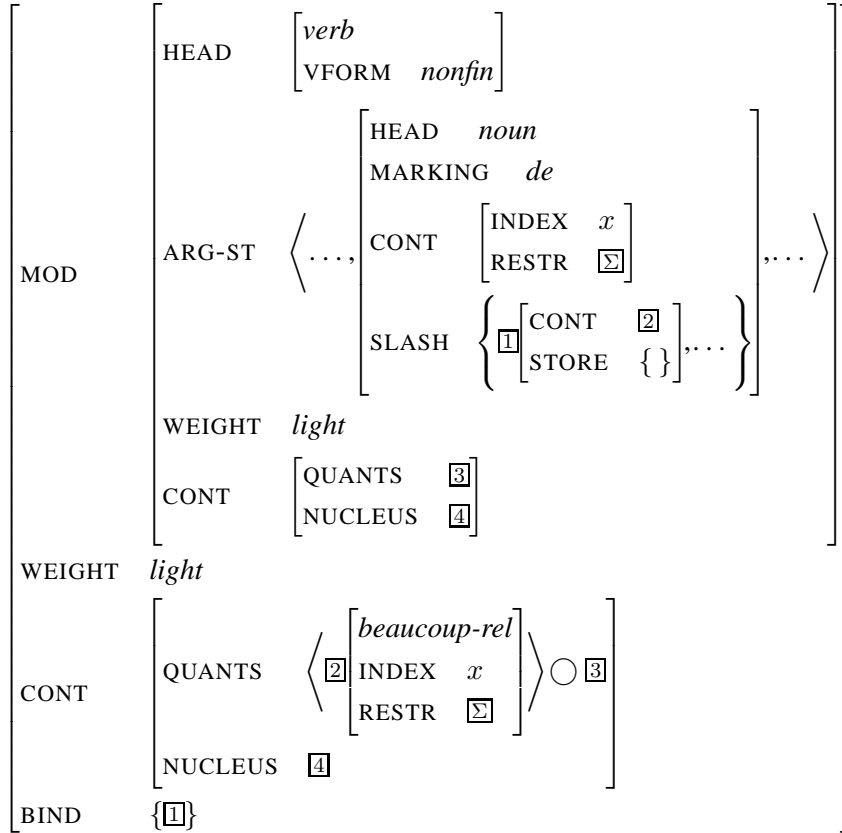

Figure 5: Lexical entry for *beaucoup* (QAD adverb)

4.4 QAD (Quantification at a distance)

To account for cases of QAD as in (20), we treat the “floating” adverb as a modifier adjoined to the non-finite verb. The relevant lexical entry for *beaucoup* is given in Figure 5. Via its MOD value, the adverb *beaucoup* selects a verb with a *de-N'* phrase on its argument structure (whose SLASH set contains a specifier). The specification [WEIGHT *light*] in the MOD value ensures that the modified category is a lexical verb (or a coordination of lexical verbs) and not a branching VP; the same WEIGHT specification on the adverb itself determines its linear position to the left of the modified verb (Abeillé and Godard, 2000).

The adverb binds the SLASH dependency lexically (licensing the autonomous *de-N'* phrase) and adds its own quantificational semantics to the QUANTS list inherited from the verb; recall that the semantic content shown here is a simplification that does not take into account the data in (23). Because the semantic contribution

weak head *de* of Figure 3 is not involved. The extracted NP is headed by the first weak head of Figure 1, which introduces no SLASH dependency. Such examples are straightforward cases of verbal argument extraction.

does not invoke the STORE mechanism, it is impossible for *beaucoup* to take any wider scope.¹⁵

4.5 Licensing of *de-N'* in negative contexts

Following de Swart and Sag (2002) and Godard (2004), we assume that French negative words (including the simple negation *pas*) are quantifiers which occur in STORE and are retrieved by a *ne*-marked verb, or by an inherently negative element like the preposition *sans*.¹⁶ Verb words are partitioned into two types, *neg-vb-wd* and *pos-vb-wd*; only *neg-vb-wd* verbs can retrieve the negative quantifiers in their STORE.

We propose that, in addition to retrieving negation, *ne*-marked verbs can also license *de-N'* phrases (bearing a non-empty SLASH). The combined constraint on *neg-vb-wd* is given here:

(41) *neg-vb-wd* →

$$\left[\begin{array}{l} \text{CONT|QUANTS} \left[\left(\text{list}(\text{quant-rel}) \circ \langle \text{neg-quant-rel} \rangle \right) \oplus \langle \underline{1}, \dots, \underline{n} \rangle \right] \\ \text{STORE} \quad \text{list}(\text{pos-quant-rel} \vee \text{param}) \\ \text{BIND} \quad \left\{ \left[\begin{array}{l} \text{HD|SPEC|MARKING } de \\ \text{CONT} \quad \underline{1} \text{ exist-rel} \\ \text{STORE} \quad \{ \} \end{array} \right], \dots, \left[\begin{array}{l} \text{HD|SPEC|MARKING } de \\ \text{CONT} \quad \underline{n} \text{ exist-rel} \\ \text{STORE} \quad \{ \} \end{array} \right] \right\} \end{array} \right]$$

The *neg-vb-wd* retrieves all stored negative quantifiers (there must be at least one). The verb can also bind specifiers that have been introduced into SLASH by *de-N'* phrases; these elements can be identified by the feature [HEAD|SPEC|MARKING *de*]. For each of these specifiers, the verb adds an existential quantifier scoping over the corresponding *de-N'* phrase to the end of its QUANTS list. (The weak head entry in Figure 3 ensures that the INDEX and RESTR of the specifier in SLASH are identified with those of the specified *N'*.) These existential quantifiers are scoped below the ordinary quantifiers retrieved from STORE, in accordance with the observations in (24–25).¹⁷

¹⁵We assume that adjuncts can modify both the NUCLEUS and QUANTS of the verb. This is independently necessary if we are to account for modal, habitual, and frequency adverbs, which can all outscope quantifiers. We must also assume that non-local features (SLASH, STORE) are amalgamated by left-adjoined adverbs and pass from non-head daughter to mother in these head-adjunct phrases.

¹⁶Here we focus on retrieval of negation by verbs. See Godard (2004) for a fuller discussion of possible negation retrieval sites in French.

¹⁷The constraint in (41) states that specifiers introduced by *de-N'* phrases are the only SLASH elements that can be bound lexically; a more elaborate constraint would be needed to make the present analysis compatible with the treatment of *en*-cliticization out of NPs proposed in Miller and Sag (1997).

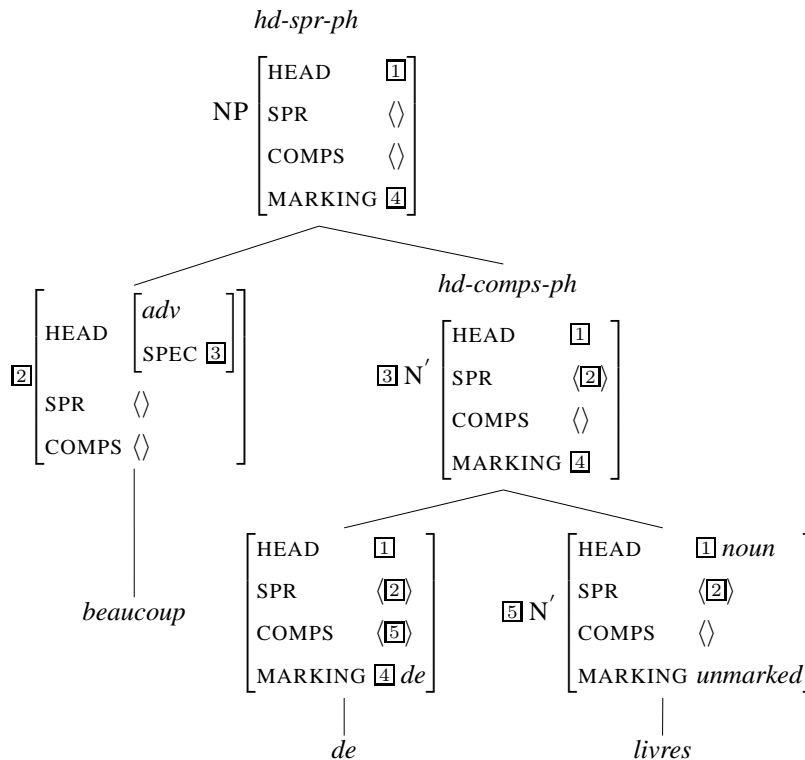

Figure 6: Local quantification [Deg *de* N'] (see section 4.1)

5 Final remarks

The proposals presented here rely heavily on the notion of weak head, an alternative to the category *marker* of standard HPSG (Tseng, 2002).¹⁸ French *de* cannot be analyzed as a marker, because it has to be able to introduce its own valence requirements—recall the lexical entry in Figure 3—and semantics, in the case of partitive *de* as in (8), for instance.

For similar reasons, the recent proposals of Van Eynde (2004) cannot be applied directly to *de*: his “functor” elements primarily contribute a new MARKING value, much like standard HPSG markers. Unlike markers, functors can make a semantic contribution, but they still cannot modify the valence of their sister category. Furthermore, Van Eynde’s treatment of specifiers as functors is also incompatible with the crucial idea in our analysis of *de*-N’ licensing: specifiers must be extractable arguments.

Van Eynde’s notion of “minor category” could be useful for capturing the functional restrictions that characterize *de*—e.g., it cannot be modified by or conjoined

¹⁸The weak head approach has also been used in the analysis of coordinating conjunctions (Abeillé, 2003).

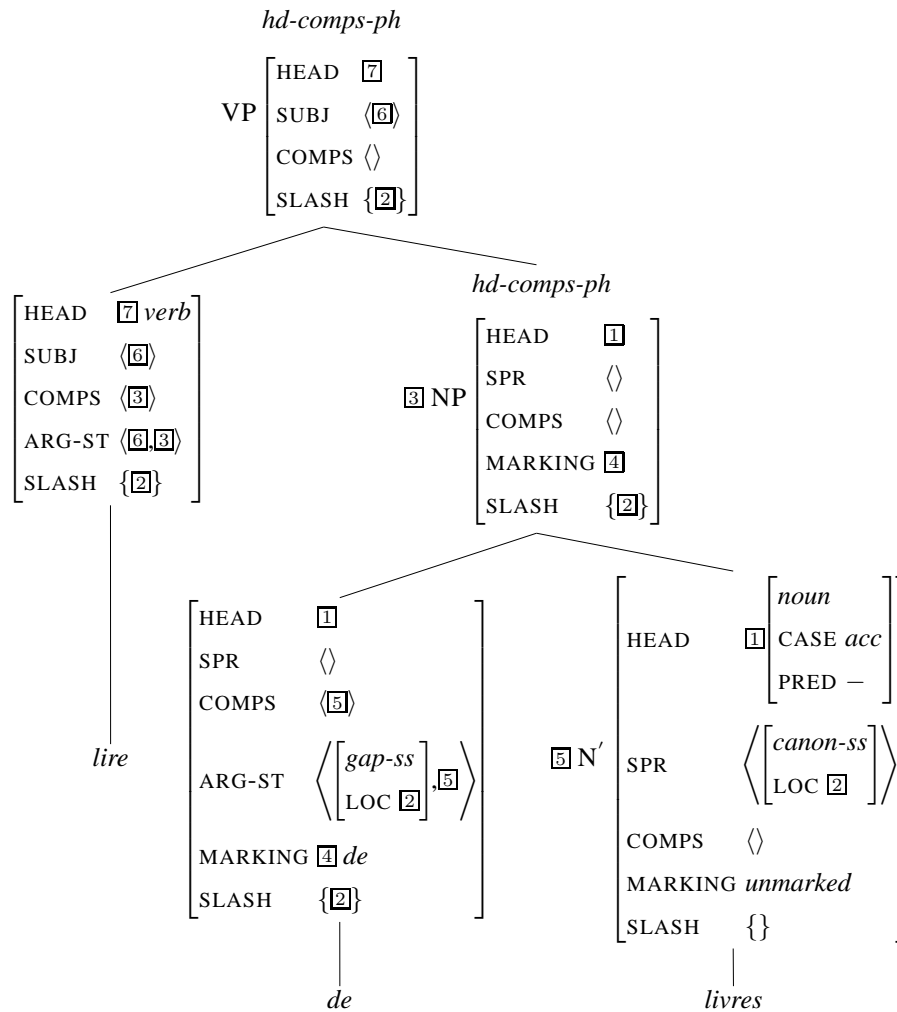

Figure 7: Autonomous *de*-N' in need of licenser (see section 4.2)

with another element, or used in isolation. But these restrictions apply to all uses of *de*, including oblique (i.e., prepositional) uses that would clearly be “major” in Van Eynde’s system. It is possible that the details of the major/minor dichotomy could be adapted; alternatively these properties of *de* could be analyzed as part of the theory of syntactic weight (Abeillé and Godard, 2000).

References

- Abeillé, Anne. 1997. Fonction ou position objet ? Deuxième partie. *Le gré des langues* 12, 8–33.
- Abeillé, Anne. 2003. A lexicalist and construction-based approach to coordination. In Stefan Müller (ed.), *Proceedings of the 10th International HPSG Conference*, pages 5–25, Stanford, CA: CSLI Publications.
- Abeillé, Anne and Godard, Danièle. 1999. A Lexical Approach to Quantifier Floating in French. In Gert Webelhuth, Jean-Pierre Koenig and Andreas Kathol (eds.), *Lexical and Constructional Aspects of Linguistic Explanation*, pages 81–96, Stanford, CA: CSLI Publications.
- Abeillé, Anne and Godard, Danièle. 2000. French Word Order and Lexical Weight. In Robert D. Borsley (ed.), *The Nature and Function of Syntactic Categories*, volume 32 of *Syntax and Semantics*, pages 325–360, San Diego: Academic Press.
- Abeillé, Anne and Godard, Danièle. 2003. The Syntactic Flexibility of Adverbs: French Degree Adverbs. In Stefan Müller (ed.), *Proceedings of the 10th International Conference on HPSG*, pages 26–46, Stanford, CA: CSLI Publications.
- Abeillé, Anne, Godard, Danièle, Bonami, Olivier and Tseng, Jesse. 2003. The syntax of French *à* and *de*: An HPSG analysis. In Patrick Saint-Dizier (ed.), *Proceedings of the ACL-SIGSEM Workshop on the linguistic dimensions of prepositions and their use in computational linguistics formalisms and applications*, pages 133–144, Toulouse: IRIT.
- Bonami, Olivier, Godard, Danièle and Marandin, Jean-Marie. 1999. Constituency and word order in French subject inversion. In Gosse Bouma, Erhard Hinrichs, Geert-Jan Kruijff and Richard T. Oehrle (eds.), *Constraints and Resources in Natural Language Syntax and Semantics*, pages 21–40, Stanford, CA: CSLI Publications.
- Borsley, Robert D. 2004. An approach to English comparative correlatives, paper presented at the 11th International HPSG Conference, Leuven, August 2004.
- de Swart, Henriëtte and Sag, Ivan A. 2002. Negation and negative concord in Romance. *Linguistics and Philosophy* 25, 373–417.
- Doetjes, Jenny. 1997. *Quantifiers and Selection. On the distribution of quantifying expressions in French, Dutch and English*. Ph.D.thesis, Holland Institute of Generative Linguistics, Leiden University, published by Holland Academic Graphics.
- Gaetone, David. 1971. *Etude descriptive du système de la négation*. Geneva: Droz.

- Gaatone, David. 1992. *De négatif entre syntaxe et sémantique ; Réflexions sur quelques propriétés du déterminant de*. *Langue française* 94, 93–102.
- Ginzburg, Jonathan and Sag, Ivan A. 2001. *Interrogative Investigations: The Form, Meaning and Use of English Interrogatives*. Stanford, CA: CSLI Publications.
- Godard, Danièle. 2004. French Negative Dependency. In Francis Corblin and Henriëtte de Swart (eds.), *Handbook of French Semantics*, Stanford, CA: CSLI Publications.
- Gross, Maurice. 1967. Sur une règle de cacophonie. *Langages* 7, 105–119.
- Huot, Hélène. 1981. *Constructions infinitives du français : le subordonnant de*. Geneva: Droz.
- Kayne, Richard S. 1981. ECP Extensions. *Linguistic Inquiry* 12, 93–133.
- Kehler, Andrew. 2002. *Coherence, Reference, and the Theory of Grammar*. CSLI Publications.
- Kupferman, Lucien. 2004. *Domaines prépositionnels et domaines quantificationnels : Le mot de*. Paris: Duculot.
- Miller, Philip H. and Sag, Ivan A. 1997. French Clitic Movement without Clitics or Movement. *Natural Language and Linguistic Theory* 15, 573–639.
- Milner, Jean-Claude. 1978. *De la syntaxe à l'interprétation*. Paris: Le Seuil.
- Muller, Claude. 1997. *De partitif et la négation*. In Danielle Forget, Paul Hirschbühler, France Martineau and María-Luisa Rivero (eds.), *Negation and Polarity*, pages 251–270, John Benjamins.
- Obenauer, Hans-Georg. 1994. *Aspects de la syntaxe A-barre. Effets d'intervention et mouvements des quantifieurs*. Thèse d'état, Université Paris 8.
- Tseng, Jesse. 2002. Remarks on Marking. In Frank van Eynde, Lars Hellan and Dorothee Beermann (eds.), *Proceedings of the 8th International HPSG Conference*, pages 267–283, Stanford, CA: CSLI Publications.
- Van Eynde, Frank. 2004. Minor Adpositions in Dutch. *Journal of Comparative Germanic Linguistics* 7, 1–58.

Non-restrictive relative clauses in Construction Based HPSG

Doug Arnold 

University of Essex

Proceedings of the 11th International Conference on
Head-Driven Phrase Structure Grammar

Center for Computational Linguistics, Katholieke Universiteit Leuven

Stefan Müller (Editor)

2004

Stanford, CA: CSLI Publications

pages 27–47

Arnold, Doug. 2004. Non-restrictive relative clauses in Construction Based HPSG.
In Stefan Müller (ed.), *Proceedings of the 11th International Conference on Head-Driven Phrase Structure Grammar*, Center for Computational Linguistics, Katholieke Universiteit Leuven, 27–47. Stanford, CA: CSLI Publications. DOI: 10.21248/hpsg.2004.2.



Abstract

This paper presents an account of English non-restrictive (‘appositive’) relative clauses (NRCs) in the framework of ‘construction based’ HPSG. Specifically, it shows how the account of restrictive relative clause constructions presented in Sag (1997) can be extended to provide an account of the syntax and semantics of NRCs and of the main differences between NRCs and restrictive relatives. The analysis reconciles the semantic intuition that NRCs behave like independent clauses with their subordinate syntax. A significant point is that, in contrast with many other approaches, it employs only existing, independently motivated theoretical apparatus, and requires absolutely no new structures, features, or types.

1 Introduction

Though superficially similar, English non-restrictive (‘appositive’) relative clauses (NRCs), as in (1a), differ phonologically, structurally, and semantically from restrictive relatives (RRCs), as in (1b).*

- (1) a. Kim has three pets, which a neighbour looks after. [NRC]
b. Kim has three pets which a neighbour looks after. [RRC]

Phonologically, NRCs are set off prosodically (with ‘comma intonation’ in speech, and actual commas in writing). Semantically, the most obvious difference is that RRCs are interpreted restrictively, i.e. as intersective modifiers. So, for example, the RRC in (1b) is interpreted as restricting the set of pets under consideration to a particular subset (those which the neighbour looks after). This intersective interpretation is presumably related to the fact that RRCs are incompatible with proper nouns, which are unproblematic with NRCs:

- (2) a. Kim, who has three pets, lives round the corner. [NRC]
b. *Kim who has three pets lives round the corner. [RRC]

A common effect of the intersective interpretation is to introduce an implicit ‘contrast set’, which can be accessed subsequently by anaphors like *the others*, as in (3a). In contrast, NRCs are interpreted as simply adding information about their antecedents, and have a ‘totality’ interpretation. So (1a) implies that the neighbour looks after *all* Kim’s pets. Consequently there is no possible antecedent for *the others* in (3b).

- (3) a. Kim has three pets, which a neighbour looks after. #The others fend for themselves. [NRC]

*I have presented material related to this paper to the Syntax Group at Essex, UFRL at the University of Paris 7 and the LAGB, as well as at HPSG04. I am grateful to participants at these events, and anonymous referees from the HPSG04 programme committee, for criticism and comments. Special thanks are due to Olivier Bonami, Bob Borsley, Annabel Cormack, Anette Frank, Danièle Godard, Ruth Kempson, Bob Levine, Kathleen O’Connor, Peter Sells and Henriette de Swart. Of course, I am solely responsible for remaining errors and unclaritys.

- b. Kim has three pets which a neighbour looks after. The others fend for themselves. [RRC]

Syntactically, there are two main differences. First, NRCs are always finite and +WH (hence they do not permit *that* or zero relative pronouns):

- (4) a. *He is looking for Kim, about whom to spread rumours.
b. *Kim, (for us) to talk to, has just arrived.
c. *Kim, (that) I admire, has just arrived.

Second, while RRCs are always nominal modifiers, NRCs take a much wider range of antecedents:

- (5) Kim was a skeptic/really nice/in a bad mood, which I didn't think she would be. (NP/AP/PP)
(6) Kim won the race, which was a relief/I didn't think she could. (S/VP)

Previous accounts of the differences between NRCs and RRCs have often involved giving them radically different structures (e.g. Ross, 1967; Emonds, 1979), sometimes involving major theoretical innovations, including novel kinds of grammatical operation and structure (McCawley, 1988), new levels of representation (Safir 1986; Fabb, 1990), or entirely new conceptions of grammatical structure (Espinal, 1991; Burton-Roberts, 1999). This paper will present a very different view. I will present an account of the syntax and semantics of NRCs that uses only existing, independently motivated, apparatus: essentially, just the syntax that is required for RRCs, and the semantics and pragmatics required for the interpretation of normal anaphora. Specifically, I will show how the 'construction based' account of the syntax of RRCs presented in Sag (1997) can be extended straightforwardly to provide an empirically adequate account of the syntax and semantics of NRCs, including some phenomena that appear not to have been previously noted.¹

The paper is structured as follows. Section 2 will look in more detail at the semantics of NRCs, focusing on the differences between NRCs and RRCs, and will provide an analysis which accounts for some novel phenomena. Section 3 will summarize the key ideas of Sag (1997)'s syntactic analysis of RRC, and present data that motivate a similar approach to the syntax of NRCs. I will then show how this account can be integrated with the semantic analysis and adapted to capture the syntactic differences between RRCs and NRCs. Section 4 provides a conclusion.

¹Space precludes a systematic review of the literature (but see Vries (2002), especially Chpt 6, for an excellent overview). Analyses which assume that NRCs and RRCs have broadly similar syntactic structures include those of Jackendoff (1977), Perzanowski (1980), and Kempson (2003). Within the framework of HPSG, the only work on this or related constructions that I am aware of is Holler (2003)'s account of German non-integrated Wh-clauses, which differs from this analysis in being framed in the non-construction based approach of Pollard and Sag (1994), and in suggesting the need for extra theoretical apparatus.

2 Semantics

A very widespread and appealing view of the semantics of NRCs is that non-restrictive relative pronouns are like normal anaphoric pronouns, and NRCs are interpreted like independent clauses, outside the scope of sentential operators (i.e. with ‘wide scope’). In this section, I will exploit an insight due to Sells (1985, 1986) to provide a semantics for NRCs which is consistent with this ‘discourse anaphora’ view, and with some apparently contradictory data which suggest that NRCs have, paradoxically, both wide and narrow scope *simultaneously*.

The underlying intuition here can be seen by comparison of examples involving NRCs, like (1a), and an example like (7). These have very similar interpretations. Notice, for example, that both normal pronouns and non-restrictive relative pronouns show the ‘totality’ interpretation:

- (7) Kim has three pets. A neighbour looks after them. #The others fend for themselves.

Likewise, compatibility with a wide range of antecedents is reminiscent of normal pronouns. Compare (6) with (8):²

- (8) Kim won the race. It was a relief/I didn’t think she could do it.

In fact, as with normal anaphoric pronouns, the antecedent of a non-restrictive relative pronoun need not be a grammatical constituent at all. In (9a) *which* has a ‘split’ antecedent. In (9b), *which* is interpreted as something like “the fact that the person I was put in touch with had the same first name as me”:

- (9) a. Kim bought Sandy *a book*, and Sam bought her *a pen*, which they gave her for Christmas.
b. They put me in touch with someone with the same name first name as me, which I thought was a good omen.

The similarity can also be seen in the contrast in (10), which shows that an ‘idiom part’ like *headway* can be associated with an RRC, but not an NRC (Vergnaud, 1974). As (11) shows, pronominal anaphora is similarly impossible.

- (10) a. *The headway, which the students made last week, was amazing. [NRC]
b. The headway which the students made last week was amazing. [RRC]
- (11) *The headway was amazing. The students made it last week.

One aspect of the ‘wide scope’ behaviour of NRCs is that they can have independent illocutionary force (Peterson, 2004). For example, (12a) shows an NRC with the force of an assertion embedded in a question, (12b) has an assertion embedded in a denial. Someone who utters (12c) will be taken to have made an

²No normal pronoun takes the same range of antecedents as *which*, so no single pronoun can be used to paraphrase all of (5), cf *Kim was nice. I did not think she would be (*it)*.

assertion, and also a bet for £50.

- (12) a. Are linguists, who use the IPA, invariably clever people?
b. Linguists, who use the IPA, are not invariably clever people.
c. If United win today, which I bet you £50 they won't, they will be top of the league.

Other evidence of wide scope interpretation comes from the interaction of NRCs with VP ellipsis, propositional attitude verbs, negation, and negative polarity items.

Unlike RRCs, NRCs do not give rise to strict/sloppy ambiguity with VP ellipsis (McCawley, 1988). The RRC example (13a) is ambiguous, depending on whether *her* in the elided VP *recognized the man who took her wallet* is interpreted as referring to *Sandy* or *Kim*. The NRC example (13b) is unambiguous: the elided VP in (13b) is interpreted as *saw the man*, as though the content of the NRC was not part of the VP at all.

- (13) a. Kim recognized the man who took her wallet, and so did Sandy. [RRC]
b. Kim recognized the man, who took her wallet, and so did Sandy. [NRC]

NRCs are typically interpreted outside the scope of propositional attitude verbs. The most natural reading of (14a) attributes to Kim a belief about linguists in general, and is consistent with her having no beliefs at all about the IPA. By contrast, the most natural reading of (14b) requires that Kim has beliefs about the IPA and linguists who use it. In fact, the NRC in (14a) is interpreted as an assertion of the speaker's. It is as if the content of the NRC is not part of the clause that contains it.

- (14) a. Kim believes that linguists, who use the IPA, are clever. [NRC]
b. Kim believes that linguists who use the IPA are clever. [RRC]

Similarly, NRCs are naturally interpreted outside the scope of sentence negation. In (12b) above, the main clause is a denial, but the NRC it contains is interpreted as an assertion. Likewise, while it is possible to focus negation on part of an RRC, this is not possible with an NRC (Jackendoff, 1977):

- (15) a. *We didn't talk to the man, who married SUSAN. [NRC]
b. We didn't talk to the man who married SUSAN. [RRC]

NRCs cannot contain 'externally licensed' negative polarity items (NPIs). The ungrammaticality of (16a) suggests that the NRC is outside the scope of the negative quantifier; (17a) suggest the NRC is outside the scope of the interrogative operator. Notice that NPIs in the corresponding RRCs are unproblematic.

- (16) a. *No one, who had anything to drink, suffered ill effects. [NRC]
b. No one who had anything to drink suffered ill effects. [RRC]
- (17) a. *Did Sam interview a witness, who saw anything incriminating? [NRC]
b. Did Sam interview a witness who saw anything incriminating? [RRC]

So far, the picture is rather consistent. It has often been claimed that this extends to the interaction of NRCs and quantification: specifically, that NRCs take wide scope with respect to quantified NPs, and so cannot attach to, or contain pronouns bound by, external quantifiers. Data like the following seem to support this claim (Ross, 1967):

- (18) a. *Every/No plane, which has an engine in its tail, is a failure. [NRC]
b. Every/No plane which has an engine in its tail is a failure. [RRC]

Unfortunately, the claim is false. Sells (1985, 1986) points out examples like (19a), with an indefinite in the scope of *every*:

- (19) a. Every chess set comes with a spare pawn, which you will find taped to the top of the box.
b. Every American film producer pays the lead actress, who hates his guts, a fortune. [Kamp and Reyle (1993, 255)]

The following summarizes a number of cases of NRCs attached to, and apparently in the scope of, a variety of quantified NPs:

- (20) a. Many/Most/Few/No/At least 10 candidates, all/some/three of whom have sent in their CVs, have agreed to a face to face interview.

In fact, NRCs can attach to *any* quantified NP. Consider the following, paralleling (18a) but entirely natural.

- (21) Every/No modern plane, which may or may not have an engine in its tail, is prone to this sort of problem.

It is not obvious how this can be reconciled with the observations about wide scope above. One suggestion would be that NRCs normally have wide scope, but can under certain circumstances take narrow scope. This is what Sells (1985) seems to suggest. However, this will not do, because NRCs can exhibit wide and narrow scope *simultaneously* (this seems not to have been previously noticed).

Consider (22a). This has several readings, but the most natural have *a spare pawn* in the scope of *every* (i.e. it is a possibly different spare pawn for each chess set), and both NPs in the scope of *believes*. This is summarized in (22b), using > for ‘outscopes’.³

- (22) a. Sam believes every chess set comes with a spare pawn, which Kim thinks is usually taped to the top of the box with its base uppermost.
b. believes > every chess set > a spare pawn

Notice that the NRC is in the scope of the indefinite *a spare pawn* (it contains the pronoun *its* which is bound by the indefinite). The ‘outscopes’ relation is transitive,

³Giving *every chess set* and *a spare pawn* scope wider than *believes* would give an interpretation that one might paraphrase as “Every chess set is associated with a spare pawn. Sam believes they come together”. This reading requires that the speaker herself believes that every chess set has an associated spare pawn. While clearly a possible reading, it is not the most salient.

so we would expect the NRC to be in the scope of *believes*:

(23) *believes* > every chess set > a spare pawn > NRC

But this does not reflect what (22a) means. To put it simply, (22a) says something about what Kim thinks, it is not about what Sam believes Kim thinks. To put it another way, (22a) does *not* entail (24a). The NRC is *not* in the scope of *believes*.

(24) a. Sam believes [Kim thinks it (the spare pawn) is usually taped to the top of the box with its base uppermost].
b. *believes* $\not>$ NRC.

The same point can be made (perhaps more simply) in relation to (25), which also demonstrates that this phenomenon is not just a reflection of some property of propositional attitude verbs like *believe*.

(25) No properly trained linguist, who would have come across this issue during her training, would have made that mistake.

Here the relative pronoun (and the pronoun *her*) are apparently bound by the negatively quantified NP *no properly trained linguist*, so the NRC must be in the scope of the NP.

(26) *No properly trained linguist* > NRC

Normally, such an NP will license an NPI such as *ever* in its scope, as in the following RRC:

(27) No properly trained linguist that had **ever** come across this issue during her training would have made that mistake.

But this does not happen in the NRC. Not surprisingly given the impossibility of externally licensed NPIs described above, putting *ever* in (25) leads to ungrammaticality:

(28) *No properly trained linguist, who would **ever** have come across this issue during her training, would have made that mistake.

Thus, we conclude (29), directly contradicting (26):

(29) *No properly trained linguist* $\not>$ NRC.

There seems to be a genuine paradox here. However, while the actual treatment proposed in Sells (1985) cannot deal with it, Sells' central insight about what is going on seems to be correct, and provides the basis for a solution. What Sells observed is that this apparently inconsistent behaviour of having wide scope and taking quantified NP antecedents is not unique to NRCs. The same thing occurs with normal anaphoric pronouns in independent clauses. For example, just as we have (30a), we get (30b):

(30) a. Every chess set comes with a spare pawn, which you will find taped to the top of the box.

- b. Every chess set comes with a spare pawn. You will find it taped to the top of the box.

Moreover, the conditions under which this is possible are similar. Broadly speaking, they are conditions where there is some signal of discourse continuity which triggers the kind of accommodation process known as ‘telescoping’ or ‘modal subordination’ (e.g. (Roberts, 1989, 1996), Poesio and Zucchi (1992)).⁴

Thus, where (31a/b) are both bad because the antecedent of the pronoun is in the scope of negation, the choice of irrealis tense which makes (32a) acceptable also works for an NRC, making (32b) acceptable.

- (31) a. *Sam doesn’t own a car. She drives it too fast.
b. *Sam doesn’t own a car, which she drives too fast.
- (32) a. Sam doesn’t own a car. She wouldn’t be able to drive it anyway.
b. Sam doesn’t own a car, which she wouldn’t be able to drive anyway.

Likewise, the unacceptability of (18a), repeated here as (33a), is paralleled by that of (33b). The acceptability of the examples in (21), repeated as (34a), is paralleled by that of (34b).

- (33) a. *No/Every plane, which has an engine in its tail, is a failure.
b. *No/Every plane is a failure. It has an engine in its tail.
- (34) a. Every/No modern plane, which may or may not have an engine in its tail, is prone to this sort of problem.
b. Every/No modern plane is prone to this sort of problem. It may or may not have an engine in its tail.

This extends to the ‘paradoxical’ cases: (35a) and (35b) have the same interpretation, the same ‘paradoxical’ combination of wide and narrow scope-like properties. In (36a) and (36b) we see the same combination of an illicit NPI in the same clause as a pronoun bound by a negative quantifier.

- (35) a. Sam believes every chess set comes with a spare pawn, which Kim thinks is usually taped to the top of the box with its base sticking up.
b. Sam believes every chess set comes with a spare pawn. Kim thinks it is usually taped to the top of the box with its base sticking up.
- (36) a. No properly trained linguist, who would have (*ever) come across this issue during her training, would have made that mistake.
b. No properly trained linguist would have made that mistake. She would have (*ever) come across this issue during her training.

This insight provides a way of giving a Discourse Representation Theory (DRT, Kamp and Reyle, 1993) style semantics for NRCs that accounts for the semantic

⁴I will have nothing to say here about what these conditions are: all that matters is that they are essentially the same in NRCs and discourse anaphora.

differences between NRCs and RRCs and resolves the apparent narrow/wide scope paradox.

First, consider the interpretation of a restrictive relative such as the following, and the associated Discourse Representation Structure (DRS):⁵

(37) Sam_s doesn't own a car_c which_c she_y can drive.

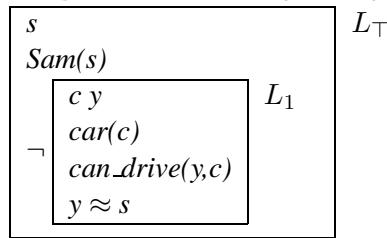

In words, this says that there is an individual s , named *Sam*, and it is not the case that there are individuals c and y , where c is a car and y is anaphorically related to the individual s , such that y can drive c . Intersective semantics and narrow scope arise because the discourse variables (c and y) and conditions from the RRC and the noun *car* appear in the same box, in the scope of negation. Consistent with most analyses (including, e.g. Pollard and Sag, 1994) I assume that the grammar co-indexes *car* and the relative pronoun (which therefore contributes neither a discourse variable nor conditions).

Now consider an example with an NRC such as (32b), or an example with an independent clause like (32a), both repeated here:

- (38) a. Sam doesn't own a car, which she wouldn't be able to drive (anyway).
 b. Sam doesn't own a car. She wouldn't be able to drive it (anyway).

Suppose that these are treated exactly alike.⁶ In particular, suppose that the content of the NRC goes into the 'top box' just as though it was the content of an independent clause (notice that proper nouns and indexicals are also treated in this way); and suppose the relative pronoun introduces a discourse variable (w), and a condition ($w \approx c$) associating it with its antecedent, just as if it was a normal pronoun. The resulting DRS is given in (40), where, for readability, the content of the NRC is shown below a dotted line.

- (39) a. Sam_s doesn't own a car_c, which_w she_y wouldn't be able to drive.
 b. Sam_s doesn't own a car_c. She_y wouldn't be able to drive it_w.

⁵For readability, I have put discourse variables as subscripts in the sentence. This, and following, DRSs are non-standard in giving 'labels' like L_{\top} , L_1 to DRSs. The role of these labels will be clarified below.

⁶The approach predicts that not all cases will be exactly alike. For example, if an NRC is associated with a non-final NP, it may introduce material which can be picked up by later anaphora. Compare:

- a. I loaned Kim, who is very fond of Dickens_i, a copy of his_i best novel.
 b. #I loaned Kim a copy of his_i's best novel. She is very fond of Dickens_i.

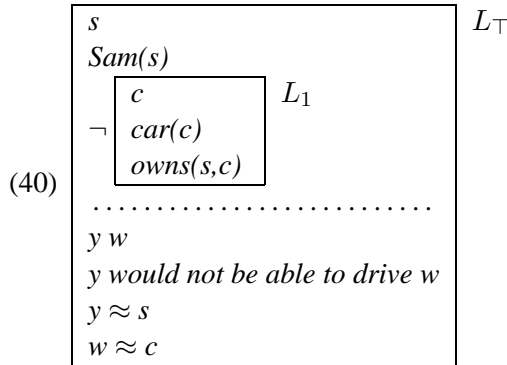

The final condition, $w \approx c$, which associates the discourse variable of *which* (or *it*) to its antecedent (the discourse variable associated with *car*), is problematic for the rules of DRS interpretation. Because the discourse variable c was introduced in a subordinate DRS, it is not accessible to this condition. So (40) is *improper*. This is what explains the deviance of examples like (31a,b) (*Kim doesn't have a car. *She drives it too fast*).

We can explain why (38a/b) are *not* problematic if we assume that some kind of accommodation process (modal subordination) occurs, whereby the hearer creates an appropriate accessible antecedent that will render the DRS proper. One way of thinking about this is as putting the content of the NRC in (38a) (and the second clause in the case of (38b)) into the consequent of a conditional, whose antecedent χ can be thought of as a kind of anaphor (Poesio and Zucchi, 1992). See (41).

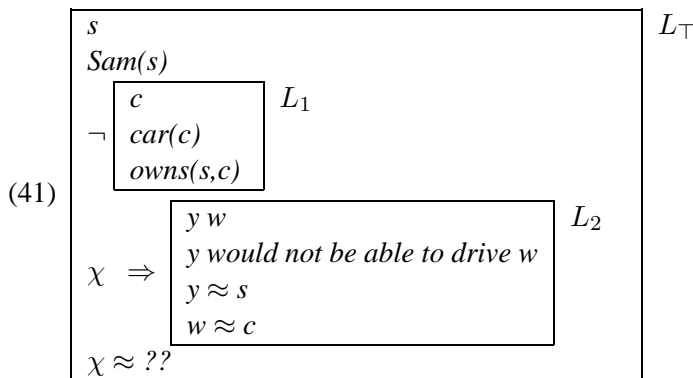

Interpreting this DRS involves finding an antecedent for χ — resolving the condition ' $\chi \approx ??$ '. The simplest resolution, based on conditions associated with the element that produced the need for accommodation (c), will be derived from L_1 — something like (42a) or (42b), corresponding to *a car that Sam owns*, and *a car that she owns*, respectively.

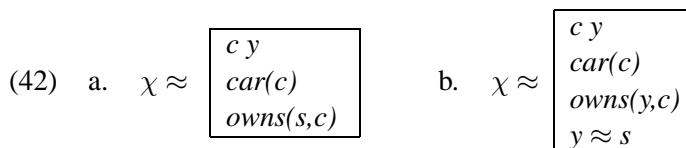

In either case the accessibility requirements will be satisfied and a proper DRS will be produced. If χ is resolved as (42a), (41) is equivalent to (43), whose truth conditions are essentially those of (44) — the correct interpretation for these examples.⁷

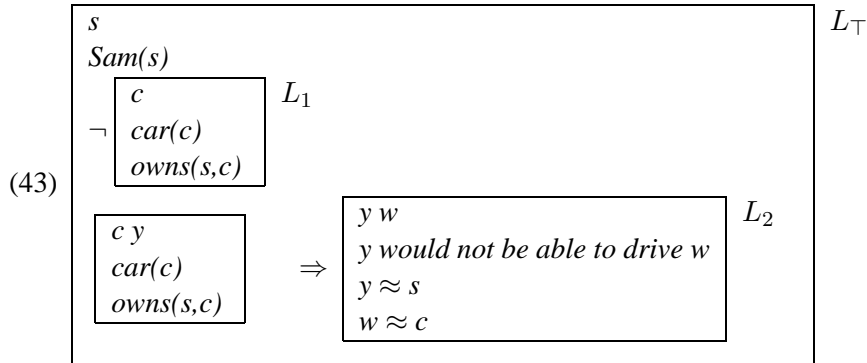

(44) Sam doesn't own a car. If Sam owned a car she wouldn't be able to drive it.

In summary, the idea is that RRCs are interpreted compositionally, in the normal way, but NRCs are interpreted non-compositionally, essentially as independent clauses, so their content goes into the 'top box'. This accounts for all the 'wide scope' phenomena described above. Notice that this does not require any novel theoretical apparatus (apart from independent clauses, 'top box' attachment is independently required for the interpretation of other proper names and indexicals). Moreover, relative pronouns in NRCs are essentially normal anaphoric pronouns. As such, their interpretation may, under certain circumstances trigger accommodation processes that appear to bring them under the scope of their antecedents, thus accounting for the possibility of narrow scope with respect to quantifiers, and the apparently paradoxical mixture of simultaneous wide and narrow scope described above. Notice again that no novel theoretical apparatus is involved: everything required is independently needed for normal anaphora.

3 Syntax: HPSG Analysis

In this section, I will provide a treatment of the syntax of relative clauses which captures the syntactic differences between RRCs and NRCs and is compatible with the semantics described above. Specifically, I will argue that Sag (1997)'s syntax for RRCs is also appropriate for NRCs, and show how it can be interfaced with the semantics presented in Section 2 and how it can be adapted to capture the special syntactic properties of NRCs.

The main features of Sag (1997)'s treatment of RRCs can be seen in (46), which represents the italicized part of (45).

⁷The occurrences of c in L_1 are independent of those in the conditional structure L_2 . For example, c could be replaced with x everywhere in L_1 without affecting things. But using different names would complicate the presentation.

(45) Sam does not own *a car which she cannot drive*.

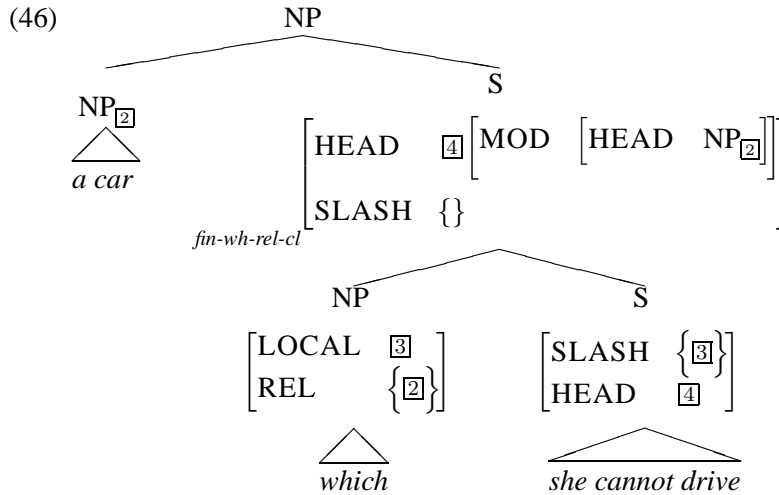

RRCs are the adjunct daughters in *head-adjunct* structures headed by NP.⁸ Accordingly, they are specified as HEAD | MOD | HEAD NP. Apart from this, they are essentially normal *head-filler* structures, whose daughters are the phrase containing the relative pronoun (the filler) and a sentence with a gap in it (the head). As usual, the LOCAL value of the filler appears in the SLASH value of the head daughter — so it will be passed down, eventually satisfying part of the subcategorization requirement of *drive*. The effect is as if the relative clause was ‘reconstructed’ as ‘*she cannot drive which*’. The only other significant point is that the index of the modified NP (*a car*), written as the subscript [2] on the NP, is an element of the REL value of the filler daughter of the relative clause. The lexical entry for the relative pronoun identifies this REL element with its index. Putting this together, the argument structure and indexation is along the lines of *a car*_{[2] (*such that*) she can drive which}_[2].

Sag’s analysis is *construction-based*, in the sense of allowing grammatical properties to be associated directly with constructions, rather than requiring that they are projected from lexical or grammatical formatives. Constructions are organized in type or sort hierarchies, where constraints on higher sorts are inherited by lower ones. For example, constraints which require relative clauses to be subordinate clauses and nominal modifiers are associated with a sort *rel-cl*. A subsort of this, *wh-rel-cl*, bears the constraint that identifies the index of the modified nominal with an element of the REL value of the filler daughter of the clause. A further subsort, *fin-wh-rel-cl*, imposes a finiteness requirement (*inter alia*). Taken together with other, orthogonal, constraints relating to the classification of constructions as

⁸This is a simplification: according to Sag, only WH-relatives are adjoined to NP, non-WH relative clauses (e.g. *everyone she trusts*, *someone to talk to*) are sisters of N’. Nothing hangs on this here. In particular, though the analysis presented here gives RRCs and NRC identical syntactic structures, it is compatible with RRCs attaching to N’, and NRCs attaching to NP, as proposed by Jackendoff (1977).

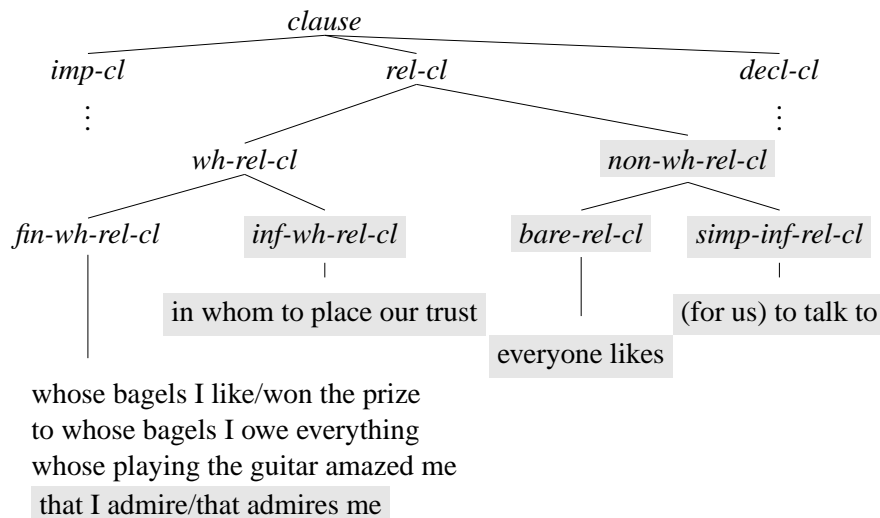

Figure 1: Classification of relative clauses according to Sag (1997). Subtypes of *rel-cl* which cannot function as NRCs are ‘greyed out’. Notice that possible NRCs all lie on the left branch under *rel-cl*.

head-filler or *head-adjunct*, etc., these constraints mean that the relevant part of (45) has the structure given in (46). The various sorts that Sag discusses imply a classification of RRCs as in Figure 1.⁹

Despite the differences between them, there is good motivation for assuming that NRCs and RRCs have essentially the same structure.

First notice that, like RRCs, NRCs appear to form constituents with their antecedents. Syntactic operations such as topicalization, raising, etc. invariably treat NRCs as though they form a constituent with their antecedents. It is impossible to topicalize (etc) the antecedent of an NRC without also topicalizing (etc) the NRC:

- (47) a. Sandy, who I’m sure you remember, I see Δ regularly.
 b. *Sandy, I see, Δ , who I’m sure you remember, regularly. [Topicalization]

- (48) a. Sandy, who I’m sure you remember, always seems Δ helpful.
 b. *Sandy always seems Δ , who I’m sure you remember, helpful. [Raising]

Notice that this is not just the result of some kind of surface adjacency requirement for NRCs and their antecedents, because there is no such requirement. For example, (49a) contains an NRC with a VP antecedent; in (49b) Heavy NP shift has moved the complement complement of the verb over the NRC — essentially

⁹Relative clauses are a kind of clause (imperatives and declaratives are other kinds), *clause* is a subset of *phrase*, and hence *sign*. There are two simplifications in Figure 1: (a) I ignore reduced relatives (*red-rel-cl*, e.g. *overlooking the park*), which are an immediate subset of *rel-cl*; (b) given the treatment of extraction in Bouma et al. (2001) there is no need for the distinction Sag makes between subtypes of *wh-rel-cl* involving subject and non-subject extraction.

putting the NRC *inside*, rather than adjacent to, the antecedent:¹⁰

- (49) a. ... noticing the cyst, which he hadn't for a long time ...
b. ... noticing, which he hadn't for a long time, the purple cyst that grew out of Horace's forehead ...

The assumption that NRCs and RRCs have the same syntactic structure predicts that NRCs should extrapose and stack in the same way as RRCs. This prediction is confirmed:¹¹

- (50) a. I saw someone yesterday that I hadn't seen for years. [RRC]
b. I saw Kim yesterday, who I hadn't seen for years. [NRC]
- (51) a. We tried to talk to footballers who are successful who (also) have good family lives. [RRC]
b. We tried to talk to Michael Owen, who is successful, who (also) has a good family life. [NRC]

Finally, consider the way possessive marking applies to NPs with NRCs and RRCs. Possessive 's always attaches to the extreme right edge of its host NP:

- (52) a. The King of England's mother left early.
b. *The King's of England mother left early

As one would expect, it also attaches after an RRC, as in (53a). Significantly, it also attaches after an NRC:¹²

- (53) a. The child *that ruined the party's* mother left early. [RRC]
b. Prince Alphonso, *who ruined the party's*, mother left early. [NRC]

Notice it is quite impossible to put the possessive before the relative in either case:

- (54) a. *The child's *that ruined the party* mother left early. [RRC]
b. *Prince Alphonso's – *who ruined the party* – mother left early. [NRC]

This follows automatically if the structures are similar: in both the possessive marker will be inside the NP, not on its the right edge. It is not obvious how the ungrammaticality of (54b) can be explained otherwise.

Turning now to the semantics, the conclusion that NRCs and RRCs have essentially the same structure poses a challenge, given the very different semantic analyses proposed for them in Section 2.

As regards the RRCs, there is very little difficulty: all that is necessary is that the semantic conditions associated with the relative clause go into the same 'box' as the conditions associated with the noun, producing the intersective interpreta-

¹⁰This is based on an attested example, cited by Potts (2002, p85, note 21).

¹¹Extrapolation and stacking are also evidence against a surface adjacency constraint (in the case of stacking, only the first NRC in a stack would satisfy such a constraint).

¹²Some speakers find examples like (53b) less than perfect, presumably because of some difficulty placing 's after an intonation break (the same effect occurs after any pause).

tion. This is just normal compositional interpretation and will be unproblematic in almost any framework. However, getting the content of NRCs into the ‘top box’ will be a problem for many frameworks, including that of Pollard and Sag (1994), where the Semantics Principle operates in a broadly compositional fashion (the CONTENT of a mother is derived from that of the daughters in the manner determined by the semantic head daughter). Notice that neither of the two ‘semi-compositional’ devices, BACKGROUND projection and Quantifier-Storage (using the QSTORE feature) can be used here. The former is inappropriate because the content of NRCs is not presupposed (e.g. it is often asserted, and cannot be canceled).¹³ The latter would not guarantee wide scope, since it would, wrongly, allow NRCs to take scope in the same way as quantifiers. In particular, it would allow them to appear inside the scope of items such as NPI licensors, propositional attitude verbs, etc.

However, the desired result can be achieved straightforwardly in the framework of Minimal Recursion Semantics (MRS, Bouma et al., 2001) or Underspecified DRT (UDRT, Frank and Reyle, 1995).

In these approaches, DRS conditions are associated with *labels* — intuitively, conditions with the same label belong to the same DRS box (cf. the examples in Section 2, which have labels on the boxes). Embedding relations between boxes are represented as relations between labels. The intersective interpretation of an RRC arises because the label on the nominal’s conditions is identified with the label on RRC’s conditions. A wide scope interpretation arises if the conditions on the NRC are assigned the label on the top box (L_{\top}). See Figure 2.¹⁴

From a theoretical point of view, this means that an additional mode of semantic combination for *head-adjunct* structures must be recognized. In addition to intersective combination (used for RRCs and other intersective modifiers) and scopal combination (lexically selected by modal adverbs like *probably* and non-intersective adjectives like *alleged*, etc), the theory must allow *head-adjunct* structures to be associated with a ‘top-level’, ‘global scope’ form of interpretation (like proper names and indexicals).

Of course, with English relative clauses RRCs and NRCs are subject to different syntactic restrictions, so the choice of intersective vs global scope semantics is not totally free. The remaining task is to account for these restrictions.

As regards RRCs, the main restriction is that they must attach to NP. NRCs

¹³The following contrast demonstrates that NRC content cannot be canceled:

- a. Kim did not regret that she resigned. She didn’t resign.
- b. #We met Kim, who resigned. She didn’t resign.

The content of the complement of *regret* is presupposed, so (a) presupposes “she (=Kim) left”. This is the same as the content of the NRC in (b). The second clause in (a) just cancels the presupposition, and (a) is felicitous. The content of the NRC cannot be canceled in this way, hence (b) is bizzare.

¹⁴In MRS terms, the value of CONTENT|HOOK|LABEL on an RRC is identified with CONTENT|HOOK|LABEL of the head noun, with NRCs it is identified with CONTENT|HOOK|GTOP.

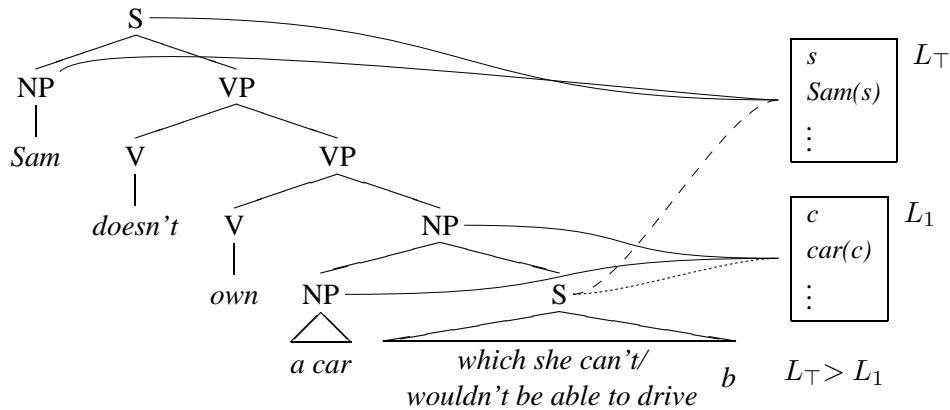

Figure 2: Alternative Semantic Interpretations for Relative Clauses: Lines link syntactic nodes with the associated DRS boxes. NRC content goes into the ‘top’ box (L_T) as indicated by the dashed line. RRC content goes into the same box as the content of the NP it modifies (L_1 , the dotted line). L_1 is subordinate to L_T .

must be WH- and finite, and cannot have *that* or zero relative pronouns. So the following are excluded:

- (55) a. *Kim, everyone likes, has just arrived. (-WH, finite, zero)
 b. *Kim, (for us) to talk to, has just arrived. (-WH, non-finite)
 c. *Kim, that I admire, has just arrived. (-WH, finite, *that*)
 d. *He is looking for Kim, about whom to spread rumours. (+WH, non-finite)

In terms of Sag’s classification, this means we must exclude: *inf-wh-rel-cl*, subtypes of *non-wh-rel-cl*, and relative clauses introduced by *that* as NRCs:

- (56) a. *Kim, everyone likes, has just left. (*bare-rel-cl*)
 b. *Kim, (for us) to talk to, has just left. (*simp-inf-rel-cl*)
 c. *Kim, that I admire has just left. (a subtype of *fin-wh-rel-cl*)
 d. *Kim, in whom to place our trust, has just left. (*inf-wh-rel-cl*)

That is, in terms of Figure 1, we have to exclude everything that is not on the left branch under *fin-wh-rel-cl* (and under *fin-wh-rel-cl* we must exclude *that* relatives).

One obvious approach might be to simply introduce NRCs as a subtype of *fin-wh-rel-cl* (and nowhere else). Non-finite NRCs would automatically be excluded. However, there would then be no place in the sort hierarchy where the distinctive properties of RRCs (especially, the intersective semantics) could be stated. In particular, associating these properties with *wh-rel-cl* or *rel-cl* would mean they would be, wrongly, inherited by NRCs as well as RRCs. Instead, we would have to leave these higher types unspecified for the NRC/RRC distinction, and associate ‘RRC-properties’ with at least two nodes in the hierarchy (*inf-wh-rel-cl* and *non-wh-rel-cl*). This is undesirable.

Fortunately, a more radical approach is possible. To begin with, suppose we assume (counter-factually) that any relative may function either restrictively or non-restrictively. This can be expressed as the constraint in (57).

(57) $rel-cl \rightarrow (intersective-semantic \vee global-scope-semantic)$

(in words: relative clauses can be intersective or non-restrictive). While this will lead to over-generation as regards NRCs, it correctly allows any kind of relative to function intersectively.

Next, suppose also that we remove the ‘HEAD | MOD | HEAD *noun*’ requirement that Sag associates with *rel-cl*. Either kind of relative will in principle then be allowed to modify anything. This will also lead to a certain amount of over-generation. However, we can immediately fix this, because though the requirement is incorrect for relatives in general, it is still correct for *restrictive* relatives, so we can restore its intended effect by (58):

(58) $(rel-cl \wedge intersective-sem) \rightarrow [HEAD | MOD | HEAD \textit{ noun}]$

(in words: restrictive relatives are always nominal modifiers).

As things stand, NRCs can attach to anything. This is perhaps too liberal. The following data suggests they should perhaps only adjoin to ‘maximal projections’ (i.e. outside complements):

- (59) a. ?Kim kicked, which I wish she hadn’t, Sandy.
 b. Kim kicked Sandy, which I wish she hadn’t.

The following constraint fixes this (this would also be an appropriate place to specify ‘comma intonation’ via a restriction on the PHON attribute):

(60) $(rel-cl \wedge global-scope-sem) \rightarrow [HEAD | MOD | HEAD [COMPS <>]]$

(in words: NRCs can only attach ‘outside’ complements)

The problem now is that we have overgeneration of NRCs because we have not dealt with the special restrictions on their syntax. Specifically, nothing excludes examples like (56), repeated here, as NRCs.

- (61) a. *Kim, everyone likes, has just left. (*bare-rel-cl*)
 b. *Kim, (for us) to talk to, has just left. (*simp-inf-rel-cl*)
 c. *Kim, that I admire has just left. (a subsort of *fin-wh-rel-cl*)
 d. *Kim, in whom to place our trust, has just left. (*inf-wh-rel-cl*)

Intuitively, excluding bare relatives (*bare-rel-cl*) is equivalent to allowing only relative clauses which are head-filler constructions (in a *bare-rel-cl* like *someone everyone likes* there is no filler for the missing object of *likes*, compare the filler *who* in *someone who everyone likes*). Excluding non-finite relative clauses (*inf-wh-rel-cl* and *simp-inf-rel-cl*) is the same as allowing only finite relative clauses. In fact, Sag already has a type *fin-head-filler-phrase* which combines these require-

ments.¹⁵ Thus, we can exclude (60a,b,d) by the following stipulation (presumably a reflection of more abstract principles, e.g. the finiteness restriction is surely related to the fact that NRCs are interpreted as essentially independent clauses):

$$(62) (rel-cl \wedge global-scope-sem) \rightarrow fin-head-filler-phrase$$

(in words, roughly: NRCs must be finite, and have preposed wh-phrases)

It remains to exclude NRCs with *that* such as (61c). This requires a little more work. Of course, the problem only arises because Sag analyzes *that* as a relative pronoun. If this is wrong, and it is not a relative pronoun, then there is nothing more to say: *that*-relatives will not be filler-head phrases, and so will be excluded by (62). However, as Sag observes, the grammaticality of (63) in some dialects suggests that *that* is a relative pronoun in at least those dialects.¹⁶

$$(63) \text{ This is the pencil that's lead is broken. [Hudson (1990)]}$$

First, consider the difference in CONTENT between relative pronouns in RRCs and NRCs. Recall the assumption above that relative pronouns in RRCs contribute nothing to the semantics (i.e. they have no role other than ensuring correct variable binding), whereas relative pronouns in NRCs are genuine anaphoric pronouns, which contribute at least a condition of the form $x \approx y$.

Now consider the nature of REL values, which are the distinguishing attribute of relative pronouns (and whose percolation is responsible for pied-piping effects in relative clauses). It is normally assumed that REL values are sets of indices, reentrant with CONTENT | INDEX values in relative pronouns. This is different from QUE values, which perform a similar function in interrogatives. QUE values are sets of *npros* — that is, intuitively, CONTENT values: indices with associated RESTR(iction)s. Compare the lexical entries for relative and interrogative *who* in (64), based on Pollard and Sag (1994):

$$(64) \quad \begin{array}{ll} \textit{who} \text{ (relative)} & \textit{who} \text{ (interrogative)} \end{array}$$

$$\left[\begin{array}{ll} \text{CAT} & \text{NP} \\ \text{CONT} & \left[\text{INDEX } \boxed{1} \right] \\ \text{REL} & \left[\begin{array}{l} \textit{npro} \\ \{ \boxed{1} \} \end{array} \right] \end{array} \right] \quad \left[\begin{array}{ll} \text{CAT} & \text{NP} \\ \text{CONT} & \left[\begin{array}{l} \boxed{1} \left[\text{INDEX } \boxed{2} \right] \\ \text{RESTR } \{ \textit{person}(\boxed{2}) \} \end{array} \right] \\ \text{QUE} & \left[\begin{array}{l} \textit{npro} \\ \{ \boxed{1} \} \end{array} \right] \end{array} \right]$$

Suppose this assumption about REL values is wrong. Suppose instead that they are sets of *npros*, just like QUE values. The implication is that the REL values of non-restrictive relative pronouns will have non-empty RESTRs, whereas in restrictives the corresponding values will be empty. This can be expressed as

¹⁵Sag defines a *fi n-head-fi ller-phrase* as a *head-fi ller-ph* whose head daughter is a saturated finite clause, i.e. HD-DTR | HEAD | VFORM *fi n* and HD-DTR | SUBJ <>.

¹⁶It is also possible that *that* NRCs should not be excluded, see e.g. Quirk et al. (1972, p871).

(65a) and (65b).

- (65) a. $(rel-cl \wedge global-scope-sem) \rightarrow$
[NON-HD-DTR | REL { [RESTR *ne-set*] }]
b. $(rel-cl \wedge intersective-sem) \rightarrow$
[NON-HD-DTR | REL { [RESTR *e-set*] }]

The exclusion of *that* from NRCs will then follow from the assumption that it has empty RESTRs, expressing the fact that, though it is a relative pronoun, it is not a ‘real’ (anaphoric) pronoun.

This proposal is not unmotivated. Consider the analysis of ‘epithet’ relative expressions like *which beverage* in (66).

- (66) a. Kim refused a drink of beer, which beverage she never touches.
b. Kim threatened to resign, which offer were were happy to accept.
c. Kim is always optimistic, which property I have always admired.

A natural analysis of these is as a kind of ‘derived relative pronoun’. Since the content of such expressions will certainly have non-empty RESTRictions (at least a restriction of *which beverage* to beverages), the current proposal predicts they should be in complementary distribution with *that* in relative clauses. This prediction is confirmed. Where *that* is excluded from NRCs, ‘epithet’ relative expressions can appear in NRCs like (66), but are excluded from RRCs:

- (67) a. *Kim refused a drink of beer which beverage she never touches. [RRC]

This section has argued that the kind of syntax that Sag (1997) provides for RRCs is also appropriate for NRCs. It has shown how Sag’s treatment can be combined with the semantics introduced in Section 2 to provide an account of the syntactic properties of NRCs, and the differences between NRCs and RRCs. A notable feature of the treatment is that, apart from the modification to REL values suggested to deal with ‘*that*-relatives’, it has required absolutely no new structures, features, types or operations.

4 Conclusion

This paper has provided an account of English NRCs which deals with their main syntactic and semantic properties, and captures the similarities and differences between NRCs and RRCs. The essence of the analysis is that NRCs are syntactically subordinate but behave semantically like independent clauses. The key ingredients of the analysis are, from the syntactic side, Sag (1997)’s treatment of restrictive relatives, and, from the semantic side (i) the idea of NRCs as having wide-scope, hence being introduced (like proper names and indexicals) into the ‘top box’ of the discourse structure, and (ii) the idea that pronouns in NRCs work like normal pronouns, triggering accommodation processes under appropriate conditions. The

analysis exploits a variety of devices in a novel way, but (modification of REL values apart) it has employed only existing, independently motivated, structures, features, and types. This seems a significant result considering the radical innovations that have sometimes been thought necessary.

References

- Bouma, Gosse, Malouf, Robert and Sag, Ivan A. 2001. Satisfying constraints on extraction and adjunction. *Natural Language and Linguistic Theory* 19(1), 1–65.
- Burton-Roberts, Noel. 1999. Language, Linear Precedence and parentheticals. In Peter Collins and David Lee (eds.), *The Clause in English*, volume 45 of *Studies in Language Companion Series*, pages 33–51, Amsterdam: John Benjamins.
- Emonds, J. 1979. Appositive relatives have no properties. *Linguistic Inquiry* 10, 211–242.
- Espinal, M.T. 1991. The Representation of Disjunct Constituents. *Language* 67, 726–762.
- Fabb, Nigel. 1990. The Difference Between English Restrictive and Non-Restrictive Relative Clauses. *Journal of Linguistics* 26, 57–78.
- Frank, Anette and Reyle, Uwe. 1995. Principle based semantics for HPSG. In *Proceedings of 7th Conference of the European Chapter of the Association for Computational Linguistics*, pages 9–16, Dublin.
- Holler, Anke. 2003. An HPSG Analysis of the Non-Integrated Wh-Relative Clauses in German. In Stefan Müller (ed.), *Proceedings of the HPSG-2003 Conference, Michigan State University, East Lansing*, pages 222–235, Stanford: CSLI Publications.
- Hudson, R. 1990. *English Word Grammar*. Oxford: Basil Blackwell.
- Jackendoff, R. 1977. *X-bar Syntax: a Study of Phrase Structure*. Cambridge, Mass: MIT Press.
- Kamp, H. and Reyle, U. 1993. *From Discourse to Logic*. Dordrecht: Kluwer Academic Publishers.
- Kempson, Ruth. 2003. Nonrestrictive Relatives and Growth of Logical Form. In *Proceedings of the West Coast Conference on Formal Linguistics*, volume 22, pages 301–314.
- McCawley, J.D. 1988. Parentheticals and Discontinuous Constituent Structure. *Linguistic Inquiry* 13, 91–106.

- Perzanowski, D. 1980. Appositive Relatives Do Have Properties. In *Proceedings of the 10th Northeast Linguistic Society Meeting (NELS X)*, pages 355–368, Ottawa.
- Peterson, Peter. 2004. Non-Restrictive Relatives and Other Non-Syntagmatic Relations in an LF Framework. In *Proceedings of LFG 2004*, Christchurch, NZ.
- Poesio, Massimo and Zucchi, Alessandro. 1992. On Telescoping. In C. Barker and D. Dowty (eds.), *Proceedings of the Conference on Semantics and Linguistic Theory II*, Columbus, Ohio.
- Pollard, Carl J. and Sag, Ivan A. 1994. *Head-Driven Phrase Structure Grammar*. Chicago: University of Chicago Press.
- Potts, Christopher. 2002. The Syntax and Semantics of *As*-Parentheticals. *Natural Language and Linguistic Theory* 20(3), 623–689.
- Quirk, R., Greenbaum, S., Leech, G. and Svartvik, J. 1972. *A Grammar of Contemporary English*. London: Longman.
- Roberts, Craige. 1989. Modal Subordination and Pronominal Anaphora in Discourse. *Linguistics and Philosophy* 12(6), 683.
- Roberts, Craige. 1996. Anaphora in Intensional Contexts. In Shalom Lappin (ed.), *The handbook of Contemporary Semantic Theory*, pages 215–246, Oxford: Blackwell.
- Ross, J.R. 1967. *Constraints on Variables in Syntax*. Ph.D.thesis, MIT, (published 1986, as *Infinite Syntax*, Norwood, Ablex Publishing Corp).
- Safir, K. 1986. Relative Clauses in a Theory of Binding and Levels. *Linguistic Inquiry* 17, 663–698.
- Sag, Ivan A. 1997. English Relative Clause Constructions. *Journal of Linguistics* 33(2), 431–484.
- Sells, P. 1986. Coreference and Bound Anaphora: a Restatement of the Facts. In J.-W. Choe S. Berman and J. McDonough (eds.), *Proceedings of NELS 16*, University of Massachusetts.: GSLA Department of Linguistics.
- Sells, Peter. 1985. Restrictive and Non-Restrictive Modification. Technical Report CSLI-85-28, Stanford University. Center for the Study of Language and Information.
- Vergnaud, J-R. 1974. *French Relative Clauses*. Ph.D.thesis, MIT, Cambridge, Mass.
- Vries, M. de. 2002. *The Syntax of Relativization*. Ph. D.thesis, University of Amsterdam, published by LOT, Utrecht (LOT, Vol 53).

Coordinate ellipsis and apparent non-constituent coordination

John Beavers 
University of Texas

Ivan A. Sag
Stanford University

Proceedings of the 11th International Conference on
Head-Driven Phrase Structure Grammar

Center for Computational Linguistics, Katholieke Universiteit Leuven

Stefan Müller (Editor)

2004

Stanford, CA: CSLI Publications

pages 48–69

Beavers, John & Ivan A. Sag. 2004. Coordinate ellipsis and apparent non-constituent coordination. In Stefan Müller (ed.), *Proceedings of the 11th International Conference on Head-Driven Phrase Structure Grammar*, Center for Computational Linguistics, Katholieke Universiteit Leuven, 48–69. Stanford, CA: CSLI Publications. DOI: 10.21248/hpsg.2004.3. 

Abstract

Within the tradition of Categorical Grammar, so-called ‘non-constituent’ coordination (‘argument cluster’ coordination and ‘right node raising’) has been analyzed in terms of the coordination of nonstandard constituents produced by the operations of type raising and composition. This highly successful research has expanded the domain of data that modern analyses of coordination must take into account. Recent HPSG work by Yatabe (2002) and Crysmann (2003) provides an interesting alternative approach to this problem in terms of the coordination of familiar, but ‘elliptical’ constituents. We argue that this approach is empirically superior to the Categorical Grammar analysis, both in terms of empirical coverage and cross-linguistic predictions. We reassess the relevant English data in small but important ways, and develop our own ellipsis analysis, building on Yatabe’s and Crysmann’s insights.

1 Introduction

In this paper we examine various coordination constructions, including constituent coordination (1a,b) as well as non-constituent coordination (NCC) phenomena such as argument cluster coordination (ACC) (1c,d), right node raising (RNR) (1e), and combinations of RNR and ACC (1f).

- (1) a. [We gave Jan a cake] and [we gave Yo a book]. (Constituent Coordination)
- b. We [gave Jan a cake] and [gave Yo a book]. (Constituent Coordination)
- c. We gave [Jan a cake] and [Yo a book]. (ACC)
- d. We visited [Jan on Monday] and [Yo on Tuesday]. (ACC)
- e. [Jan visited and Yo refused to visit] my stepmother’s father. (RNR)
- f. [Kim told Pat that Jan visited] and [Sandy that Yo refused to visit] [my stepmother’s father] (ACC+RNR)

Phenomena such as ACC and RNR have been taken as providing strong evidence for some form of Combinatory Categorical Grammar (CCG), which allows coordination of non-standard constituents. Typical CCG analyses of NCC (Dowty, 1988; Steedman, 1989, 1996, 2000) are based on the notions of type raising (**T**) and function composition (**B**). An example analysis of ACC is given in (2), where the argument NPs of the verb *give* are type raised to function categories and combine to form larger constituents via function composition. The resulting constituents

[†]Part of this work was supported by several grants from the University of Edinburgh under the Edinburgh-Stanford Link as well as the LinGO project at CSLI, Stanford University. We would like to thank the following people for helpful discussions and/or useful suggestions: Anne Abeillé, Bob Borsley, Rui Chaves, Berthold Crysmann, Dan Flickinger, Jonathan Ginzburg, Bob Levine, Mark Steedman, and Shūichi Yatabe. Sag would also like to acknowledge a decade of discussions of these issues with Jim Blevins, whose ideas have contributed immensely to our own. Of course, we alone are responsible for any errors, inaccuracies, distortions, or misrepresentations.

are coordinated following a general coordination schema, and the coordinated constituent takes the verb *give* and the subject NP as its arguments via function application, producing a sentence:

$$\begin{array}{ccccccc}
 (2) & \text{We} & \text{gave} & \text{Jan} & \text{a record} & \text{and} & \text{Yo} & \text{a book} \\
 & \overline{NP} & \overline{DTV} & \overline{NP} & \overline{NP} & \overline{CONJ} & \overline{NP} & \overline{NP} \\
 & & & \overline{TV \setminus DTV} <T & \overline{VP \setminus TV} <T & & \overline{TV \setminus DTV} <T & \overline{VP \setminus TV} <T \\
 & & & \overline{VP \setminus DTV} <B & & & \overline{VP \setminus DTV} <B & \\
 & & & & & & \overline{VP \setminus DTV} <\Phi> & \\
 & & & & & & \overline{VP} < & \\
 & & & & & & \overline{S} < & \\
 & & & & & & \text{(where } VP = (S \setminus NP), TV = (VP \setminus NP), \text{ and } DTV = (TV \setminus NP)) &
 \end{array}$$

Type raising and function composition are the same two mechanisms that independently license unbounded dependency constructions (UDCs) in CCG. In (3) the direct object of *likes* is left-dislocated and assigned a special topicalization category, and the subject NPs *Yo* and *Jan* undergo type raising. The non-topicalized constituents compose to produce a phrase of category S/NP , which serves as the argument of the topicalized NP to produce a sentence:

$$\begin{array}{ccccccc}
 (3) & \text{Bagels,} & \text{Yo} & \text{said} & \text{that} & \text{Jan} & \text{likes!} \\
 & \overline{S/(S/NP)} & \overline{S/\overline{VP}} >T & \overline{VP/S} & \overline{S/S} & \overline{S/\overline{VP}} >T & \overline{VP/NP} \\
 & & & & & \overline{S/NP} >B & \\
 & & & & & \overline{S/NP} >B & \\
 & & & & & \overline{VP/NP} >B & \\
 & & & & & \overline{S/NP} >B & \\
 & & & & & \overline{S} > &
 \end{array}$$

Since type raising and function composition are central to the CCG analysis of UDCs, and furthermore generate NCC structures more or less for free, proponents of CCG argue for its superior explanatory power on the grounds that the existence of coordinations like (1) is a direct consequence of the existence of extraction dependencies.

In this paper, we offer evidence that UDCs and NCC are best understood as independent and should not be reduced to a single underlying mechanism. We make this argument on the basis of constraints that distinguish UDCs from NCC, as well as typological data suggesting that it is not always the case that UDCs and NCC go hand in hand. We argue instead (following previous work by Yatabe 2002 and Crysmann 2003) that there is evidence that NCC should be treated instead as a form of ellipsis, something that can be captured in a straightforward manner via the linearization machinery first proposed by Mike Reape (see, for example, Reape 1994). In addition, we reassess certain generalizations about the data considered in

previous approaches to NCC in an effort to streamline the ellipsis-based analysis and expand it to a broader base.

2 Isolating NCC from Extraction

We begin by providing evidence that NCC and UDCs are two separate phenomena that should not be reduced to one another. The first piece of evidence comes from island constraints. Unlike leftward extraction, RNR fails to show island constraint effects (Wexler and Culicover, 1980). For example, in (4a) the NP *those pictures of Qaddafi* has been extracted out of a complex NP in the conjoined main clause, violating the Complex NP Constraint and thus reducing its acceptability. However, if this NP is right node raised as in (4b) the resultant sentence is unexceptional:

- (4) a. ??Those unflattering pictures of Qaddafi, Yo knows several men who buy __ and Jan knows several men who sell __ .
 b. Yo knows several men who buy __ , and Jan knows several men who sell __ , those unflattering pictures of Qaddafi.

This suggests that the two phenomena are subject to different constraints, a fact that is not predicted if they are the direct result of a single mechanism. It should be noted, of course, that island constraints themselves involve tenuous data, and acceptability of UDCs from various adjuncts depends to a large degree on context and processing factors (see, for example, Kluender 1992). But the relative ease with which the NP in (4b) can be right node raised nonetheless suggests an asymmetry between this and the extraction illustrated in (4a).

A second, and more serious criticism of the reduction of NCC to UDCs comes from typological considerations. CCG approaches make a very strong prediction about language types: since type raising and function composition are central to CCG analyses of UDCs and in turn always produce the possibility of NCC, then CCG predicts that any language that has UDCs should likewise have NCC. But there is significant evidence suggesting that this is not the case. Koutsoudas (1971), in his survey of ‘conjunction reduction’ (NCC, in our terms), lists fifteen languages that systematically lack ACC, RNR, and Verb/Verb coordination. Of these fifteen languages, nine are SVO. And of these nine, at least two are known to have unbounded leftward extraction: Hausa (Davis, 1992; Newman, 2000) and Indonesian (Chung, 1976).

Let us focus on Hausa for the moment. Hausa is an SVO, *pro*-drop language with relatively little scrambling. But it does exhibit a variety of leftward extraction phenomena, including topicalization, a number of focus operations, clefting, and *wh*-extraction:

- (5) a. gaa mootocin da su kee duubaawaa da gyaaraawaa
 here are cars+DL Rel 3pl,Rcnt inspecting and repairing
 ‘Here are the cards that they’re inspecting and repairing.’

- b. mee suka karantaa kuma suka rubuutaa
 what 3pl,Rpf read also 3pl,Rpf write
 ‘What did they read and did they write?’ (Davis, 1992, (15))

However, according to Koutsoudas and Davis, Hausa systematically lacks any type of coordination other than S, NP, and PP coordination (see also Newman 2000). If leftward extraction is the result of type raising and function composition, whose very existence in a language entails that NCC must also exist, then CCG erroneously predicts that Hausa and languages like it must have NCC.

One possible counterproposal (following Davis’s own HPSG analysis of coordination in Hausa) might be that the CCG coordination category/schema for Hausa be restricted only to ‘maximal projections’, which in CCG would correspond to the S, NP, and PP categories. However, this proposal, which would rule out the higher type function categories necessary for NCC, would also rule out across-the-board (ATB) extraction, which necessarily involves coordination of function categories (e.g. verbs). But as the examples in (5) demonstrate, Hausa definitely allows ATB extraction. Hence, no proposal to eliminate function category coordination from the grammar of Hausa seems tenable since in general it does not appear that any natural restriction on coordination in Hausa will simultaneously allow the various observed extraction phenomena (including ATB extraction), but rule out NCC.¹ These observations suggest that ACC and RNR should not be tied directly to extraction. Now that we have argued that extraction and NCC are separate phenomena, in the next section we present evidence that the correct analysis for NCC should be ellipsis-based.

3 Positive Evidence for an Ellipsis-Based Account of NCC

In addition to the criticisms raised above, the data in (6) are also problematic for the CCG account of ACC.

- (6) a. Jan travels to Rome tomorrow, to Paris on Friday, and will fly to Tokyo on Sunday.
 b. Jan wanted to study medicine when he was 11, law when he was 13, and to study nothing at all when he was 18.
 c. Yo either visits Jan on Monday, Pat on Tuesday, or else will visit them both at the end of the week. (cf. Milward 1994)

Assuming (with CCG) that all conjuncts are constituents and that only constituents of like category can coordinate, then the constituent status of the second conjunct in the non-parallel coordination examples in (6) (e.g. *to Paris on Friday* in (6a)) is paradoxical, since unlike its two fellow conjuncts, it is not a VP. One solution to this would be to assume, following Collins (1996, 1997) and Hockenmaier

¹We hope to further pursue the cross-linguistic issues raised here in future research.

(2003), that the commas should be treated as conjunctions. From this assumption, one could analyze (6a) in CCG along the following lines:²

$$\begin{array}{ccccccc}
 (7) & \text{travels} & \text{to Rome tomorrow} & \text{to Paris on Friday} & \text{and} & \text{will fly to Tokyo Sunday} & \\
 & \frac{VP/PP}{VP/PP} & \frac{VP \setminus (VP/PP)}{VP \setminus (VP/PP)} & \frac{VP \setminus (VP/PP)}{VP \setminus (VP/PP)} & \frac{CONJ}{CONJ} & \frac{VP}{VP} & \\
 & & & & & & \\
 & & & \frac{VP \setminus (VP/PP)}{VP \setminus (VP/PP)} < \Phi > & & & \\
 & & & \frac{VP}{VP} < & & & \\
 & & & & & & \frac{VP}{VP} < \Phi >
 \end{array}$$

In this analysis, the constituents *to Rome tomorrow* and *to Paris on Friday* are formed via type raising and function composition and are coordinated independently of the third conjunct *and will fly to Tokyo on Sunday*. This crucially requires the first comma to be a coordinator on a par with *and* (or else just the possibility of null coordination of some sort). However, such a proposal falls short on two fronts. First, while it seems initially plausible for English, allowing free null coordination will massively overgenerate. The factors that govern null coordination in English appear to be pragmatic, stylistic, and perhaps processing-based, rather than grammatical:

- (8) a. i. Life... liberty... happiness. That's what we want.
 ii. ??Life, liberty, happiness is what we want.
 iii. *Life, liberty is what we want.
- b. i. We want life... liberty... happiness...
 ii. ??We want life, liberty, happiness.
 iii. *We want life, liberty.
- c. i. Jan walks... talks... chews gum...
 ii. ??Jan walks, talks, chews gum.
 iii. *Jan walks, chews gum.

In (8) the acceptability of null coordination seems inversely proportional to how many conjuncts there are, where null coordination of two conjuncts is plainly ungrammatical. This is a serious problem for the analysis in (7), since that analysis crucially involves binary coordination. Furthermore, significant pauses dramatically improve the acceptability of null coordination, regardless of how many conjuncts are involved, suggesting that this phenomenon may be best analyzed in terms of replanned sentences, rather than as instances of grammatical coordination. By contrast, the sentences in (6) are perfectly acceptable with fluid intonation, a fact that speaks against an analysis in terms of replanned sentences.

Second, if the sentences in (6) did involve two coordinations, then this would make certain semantic predictions as well, since the two coordinations would be independent of one another and thus should not bear any necessary semantic inter-relationship. For example, there is no reason in principle why the sentence in (9)

²Thanks to Mark Steedman for suggesting this analysis; see also the LFG approach of Maxwell and Manning (1996) which assumes something similar.

could not have an analysis where the lower (null) coordination is conjunctive and the upper (overt) coordination is disjunctive:

- (9) Jan wanted to study medicine when he was 11, law when he was 13, or to study nothing at all when he was 18.

However, no such reading exists – the only acceptable reading is that Jan wanted to study medicine when he was 11, or law when he was 13, or nothing at all when he was 18. Thus on both syntactic and semantic grounds, there appears to be little evidence to suggest that the analysis in (7) will account for the data in (6) (see also Borsley (to appear) for arguments against null coordination in other contexts).

An alternative analysis, which we advocate, involves treating (6) as standard VP coordination in which the second and third conjuncts form a coordinate VP which is subject to left-peripheral ellipsis under identity with the first conjunct:

- (10) Jan [[travels to Rome tomorrow], [~~travels~~ to Paris on Friday], and [will fly to Tokyo on Sunday]].

This eliminates null coordinators and preserves an identical structure for both constituent coordination and NCC. Right node raising is likewise amenable to this analysis, albeit with right-peripheral ellipsis within the left conjunct:

- (11) Mary cooked a ~~pizza~~ and Bill ate a pizza.

Of course, regular constituent coordination is handled by an ellipsis mechanism – it is the limiting case where no material has been elided. The question is whether there is any corroborating evidence for an ellipsis-based approach. Here we think there are a number of suggestive pieces of evidence. First, the analysis in (10) captures the essential insight that the examples in (6) are semantically instances of regular VP coordination, i.e. that there are three traveling events in (6a). This is of course one of the essential insights of the CCG analysis (captured for example in terms of type raising to S-rooted categories for ACC with ditransitive verbs) which is preserved in the ellipsis-based alternative. Second, certain evidence from the coordination of unlikes also suggests an ellipsis-based account. Examples like (12), for example, are more straightforwardly analyzed as instances of left-peripheral ellipsis of the copula:

- (12) a. Jan [[is a Republican] and [~~is~~ proud of it]].
b. Jan [[wanted another doughnut] and [~~wanted~~ to leave Boston by five sharp]].

Previous HPSG proposals (e.g. Sag 2002) have analyzed (12a) in terms of features (e.g. PRED) whose values are neutralized in coordination. Likewise, in CCG it would be assumed that all predicative phrases have an (S\NP) category for predicative constructions, assigned lexically or via a metarule (see Carpenter 1992;

Beavers 2004). In both cases this involves additional construction-specific machinery. Our approach treats both this example and (12b) as simple VP coordination without additional features or category assignment. If nothing further is said, our analysis will not assign constituent status to sequences like *a Republican and proud of it*.

At first blush, it might appear that examples like the following, cited as fully grammatical by (Munn, 2000) and Yatabe (this volume), provide support for some variant of the neutralized category analysis which recognizes strings like *a demagogue and proud of it* as constituents:

- (13) a. ?Stupid or a liar is what Pat is __ .
 b. ?What he was __ was a demagogue and proud of it.

If *stupid or a liar* doesn't form a constituent in a sentence like *Pat is stupid or a liar* then one would expect it not to be extractable, an expectation seemingly contradicted by (13a). However, these examples do have analyses via ellipsis, and such analyses involve no neutralized categories, as sketched in (14):

- (14) a. Stupid ~~is what Pat is~~ __ or a liar is what Pat is __ .
 b. What he was __ was a demagogue and ~~what he was~~ __ was proud of it.

Here right- or left-peripheral material is elided under identity with similar material in the other conjunct, producing examples that only appear to involve the extraction of neutralized categories. Furthermore, certain facts about the acceptability of these data may actually provide further support for an ellipsis-based analysis. In particular, UDCs of this type tend to be less acceptable than their non-coordinate counterparts:

- (15) a. ?What he was __ was [a demagogue and proud of it].
 (cf. What he was __ was a demagogue. What he was __ was proud of it.)
 b. ??...and [a demagogue and angry], he was __ !
 (cf. ...and angry, he was __ !; ...and a demagogue, he was __ !)
 c. ??It was [a demagogue and angry] that he appeared to be __ .
 (cf. It was a demagogue that he appeared to be __ .
 It was angry that he appeared to be __ .)

An account in which coordinated unlikes form neutralized constituents would predict that these constituents should be as extractable as each conjunct would be alone. However, in an ellipsis-based analysis it is possible to understand this reduced acceptability in terms of various processing factors and competing constraints. First, the simultaneous presence of (SLASH-based) extraction and ellipsis yields a sentence whose analysis is more complex than that of sentences without

ellipsis or extraction. Furthermore, the interaction between extraction and ellipsis in these examples involves constraints that are rather at odds with one another, since in each case an extraction site has been elided, thus ‘stranding’ a filler without an overtly recoverable gap (despite the existence of a parallel non-elided gap). In addition, in the case of (14a), there is non-optimal focus placement since the unelided material in the right conjunct is ordinarily focused in RNR. Thus a combination of competing factors in the ellipsis-based analysis may actually explain the reduced acceptability of these examples, which remain rather difficult to explain in approaches based on neutralization.

Ellipsis-based analyses also predict the possibility of NCC of unlikes:

- (16) John gave Mary a book and to Peter a record. (Crysmann 2003, citing Bob Levine.)

In CCG the composed categories *Mary a book* and *to Peter a record* would not be acceptable candidates for coordination since they have two related but distinct categories $(S \setminus NP) \setminus (S \setminus NP / NP / NP)$ and $(S \setminus NP) \setminus (S \setminus NP / NP / PP)$ respectively. But an ellipsis-based approach again reduces these to simple VP (or S) coordination, predicting their acceptability.

Ellipsis-based analyses are further supported in nominal domains:

- (17) a. Every man and woman was upset by the Enron scandal.
 b. Old men and women are eligible for this benefit.

These examples are technically ambiguous between two readings: a pragmatically bizarre hermaphrodite interpretation and a full quantifier phrase interpretation (synonymous with, e.g. *every man and every woman*). On an ellipsis-based approach, this semantic ambiguity can be understood as deriving from a syntactic ambiguity between \bar{N} -coordination and an elliptical NP-coordination (where the quantifier/adjective in the second NP is elided):

- (18) a. Every [man and woman] was upset by the Enron scandal.
 b. [Every man] and [~~every~~ woman] was upset by the Enron scandal.

In sum, an ellipsis-based approach has several advantages. First, it unifies the analyses of NCC, constituent coordination, and coordination of unlikes. Second, it allows for the apparent extraction of neutralized coordinations while potentially explaining their reduced acceptability. Third, it eliminates the need for null coordinators and potentially ad hoc analyses of unlike coordination. And fourth, it preserves the essential insight of CCG that NCC is head-category coordination, e.g. that the ACC examples cited above are instances of coordination of verbal categories.

4 An Ellipsis-Based Analysis of NCC

We collapse our analyses of ACC, RNR, and constituent coordination into a general coordination schema that produces binary branching n -ary coordinate structures.³ This schema is outlined in (19), where A , B_i , C , D are strings, C is a coordinator, and the conjuncts are all of the form AB_iD , where A and D are token identical material in each conjunct and the B_i material is in each case unique:

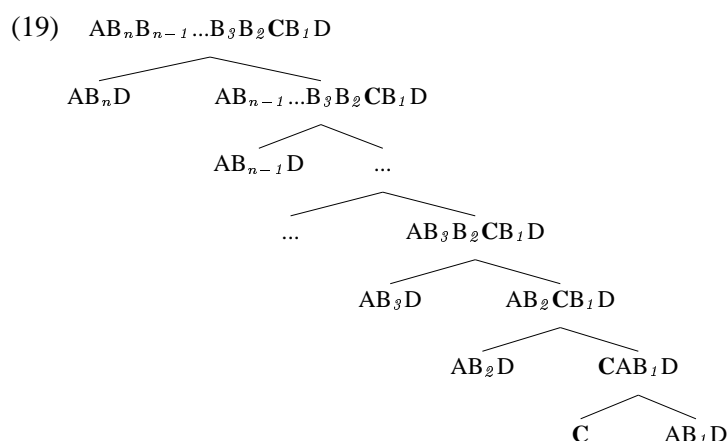

That is to say, a coordination construction takes a coordinator C and various elements of the form AB_iD and coordinates them to produce a structure of the form $AB_n\dots B_2CB_1D$, where the A and D material is preserved once in the mother and all of the unique B_i material is preserved for each conjunct. The various types of coordination fall out of this schema dependent on which parts of the strings are elided under identity, i.e. which of A and D are empty strings:

- (20)
- Constituent Coordination: $A = \epsilon$, $D = \epsilon$ (*John, Bill, and Mary*)
 - Argument Cluster Coordination: $A \neq \epsilon$ (*gave a dog a bone and a policeman a flower*)
 - Right Node Raising: $D \neq \epsilon$ (*Sandy cooked, and Mary ate, a pizza*)
 - Both Argument Cluster Coordination and Right Node Raising: $A \neq \epsilon$ and $D \neq \epsilon$ (*John told Mary that Bill, and Kim that Pat, was a die-hard fan of Gillian Welch*)

To formulate this schema in HPSG, we follow earlier proposals by Yatabe (2001) on RNR and Crysmann (2003) on ACC, employing the DOM list machinery motivated by work in linearization theory (e.g. Reape 1994). Yatabe and Crysmann show it is possible to formulate HPSG constructions (= ‘schemata’ = ‘rules’) that allow some elements in the daughters’ DOM lists to be absent from the mother’s

³However, the reader should consult Borsley (to appear) for arguments against at least some forms of binary branching coordination analyses.

DOM list. In this paper we provide such an analysis of coordination that encompasses all of the types in (20); we also reassess various details of previous analyses with regard to agreement and the range of possible semantic interpretations.

Before outlining our ellipsis-based analysis, we first establish some background assumptions. We assume a theory of constructions like that sketched by Sag (2001) and Sag et al. (2003, Ch. 16). On this approach, *signs* are feature structures whose domain includes PHON, FORM, SYN, SEM, and CNTXT, but not DTRS:

$$(21) \quad \left[\begin{array}{l} \textit{sign} \\ \text{PHON} \quad \dots \\ \text{FORM} \quad \langle \dots \rangle \\ \text{SYN} \quad \left[\begin{array}{l} \text{HEAD} \quad \dots \\ \text{GAP} \quad \langle \dots \rangle \end{array} \right] \\ \text{SEM} \quad \dots \\ \text{CNTXT} \quad \dots \end{array} \right]$$

Constructs, by contrast, are feature structures whose domain includes MOTHER (MTR) and DTRS. Constructions thus define constraints on types of constructs:

$$(22) \quad \text{a.} \quad \left[\begin{array}{l} \textit{phrasal-ct} \\ \text{MTR} \quad \left[\begin{array}{l} \textit{phrase} \\ \dots \end{array} \right] \\ \text{DTRS} \quad \langle \textit{sign}_1 \dots \textit{sign}_n \rangle \end{array} \right] \quad \text{b.} \quad \begin{array}{c} \textit{phrase} \\ \swarrow \quad \downarrow \quad \searrow \\ \textit{sign}_1 \quad \dots \quad \textit{sign}_n \end{array}$$

Finally, the well-formedness of a given *sign* is determined by the principle in (23).

- (23) **Sign Principle:** A *sign* is well-formed only if (1) it satisfies some lexical entry or (2) it is the mother of some construct licensed by one of the grammar's constructions.

On this approach, constructions themselves are not *signs*, but merely constraints that license configurations (*constructs*) as the mother *signs* within them.

4.1 Head-Marking

We assume that conjunctions are a type of marker (following Sag et al. 1985). We posit a binary feature CRD that is used to distinguish *signs* that are non-initial daughters in a (binary branching) coordinate structure ([CRD +]) from all others ([CRD –]). A conjunction combines with a [CRD –] element to form a constituent that preserves that element's MARKING value but which is specified as [CRD +]. Both these specifications are inherited from the marker daughter, whose lexical entry obeys the following constraint:

$$(24) \quad \textit{conj-lxm} \Rightarrow \left[\begin{array}{l} \text{SYN} \quad \left[\begin{array}{l} \text{MARKING} \quad \boxed{} \\ \text{SPEC} \quad \left[\begin{array}{l} \text{SYN} \quad \left[\begin{array}{l} \text{MARKING} \quad \boxed{} \end{array} \right] \\ \text{CRD} \quad - \end{array} \right] \end{array} \right] \end{array} \right] \\ \text{CRD} \quad + \end{array} \right]$$

While other markers (e.g. *that*) supply a MARKING value distinct from that of the elements they mark, a *cnj-lxm* passes the MARKING value of the marked element to its mother. This ensures that coordinations of items with non-trivial MARKING values (e.g. *that Sandy left and that Kim stayed*, where each constituent is specified as [MARKING *that*]) behave categorially like their conjunct daughters in the relevant respects. Marking constructions themselves are headed by the marked element and preserve the CRD and MARKING values of the marker while concatenating the DOM lists of the daughters:⁴

$$(25) \quad hd\text{-}mk\text{-}cxt \Rightarrow \left[\begin{array}{l} \text{MTR} \left[\begin{array}{l} \text{SYN} \left[\text{MARKING } \boxed{3} \right] \\ \text{CRD } \boxed{2} \\ \text{DOM } \boxed{A} \oplus \boxed{B} \end{array} \right] \\ \text{DTRS} \left\langle \begin{array}{l} \text{SYN} \left[\begin{array}{l} \text{HD} \quad \textit{mark} \\ \text{SPEC} \quad \boxed{1} \\ \text{MARKING} \quad \boxed{3} \end{array} \right] \\ \text{CRD } \boxed{2} \\ \text{DOM } \boxed{A} \end{array} \right\rangle, \boxed{1} \left[\text{DOM } \boxed{B} \right] \right\rangle \end{array} \right]$$

(26) is an instantiation of the head-marker construction with a conjunction as marker:

$$(26) \quad \left[\begin{array}{l} \text{FORM} \langle \textit{and, that, she, left} \rangle \\ \text{DOM} \langle \boxed{0} \left[\text{FORM} \langle \textit{and} \rangle \right], \boxed{1} \left[\text{FORM} \langle \textit{that} \rangle \right], \boxed{2} \left[\text{FORM} \langle \textit{she} \rangle \right], \boxed{3} \left[\text{FORM} \langle \textit{left} \rangle \right] \rangle \\ \text{SYN} \left[\begin{array}{l} \text{MARKING } \boxed{4} \textit{that} \\ \text{HEAD } \boxed{5} \textit{verb} \end{array} \right] \\ \text{CRD } \boxed{6} + \end{array} \right]$$

$$\left[\begin{array}{l} \text{FORM} \langle \textit{and} \rangle \\ \text{DOM} \langle \boxed{0} \rangle \\ \text{SYN} \left[\begin{array}{l} \text{MARKING } \boxed{4} \\ \text{HEAD } \textit{coord} \end{array} \right] \\ \text{CRD } \boxed{6} \end{array} \right]$$

$$\left[\begin{array}{l} \text{FORM} \langle \textit{that, she, left} \rangle \\ \text{DOM} \langle \boxed{1}, \boxed{2}, \boxed{3} \rangle \\ \text{SYN} \left[\begin{array}{l} \text{MARKING } \boxed{4} \\ \text{HEAD } \boxed{5} \end{array} \right] \\ \text{CRD} - \end{array} \right]$$

With this analysis of coordinator lexemes in place, we turn next to the syntactic constraints on ellipsis in coordination.

4.2 Syntactic Constraints on *cnj-cxt*

We posit a single coordination construction that encodes the schema in (19):

⁴For more on markers, see Pollard and Sag (1994).

(27) *cnj-cxt* \Rightarrow

$$\left[\begin{array}{l} \text{MTR} \left[\begin{array}{l} \text{DOM } \boxed{A} \oplus \boxed{B_1} \oplus \boxed{C} \oplus \boxed{B_2} \oplus \boxed{D} \\ \text{SYN } \boxed{0} \end{array} \right] \\ \\ \text{DTRS} \left\langle \begin{array}{l} \text{DOM } \boxed{A} \left\langle \left[\begin{array}{l} \text{FRM } \boxed{F_1} \\ \text{HD } \boxed{H_1} \end{array} \right] \dots \left[\begin{array}{l} \text{FRM } \boxed{F_n} \\ \text{HD } \boxed{H_n} \end{array} \right] \right\rangle \oplus \\ \boxed{B_1} \text{ne-list} \oplus \left\langle \left[\begin{array}{l} \text{FRM } \boxed{G_1} \\ \text{HD } \boxed{I_1} \end{array} \right] \dots \left[\begin{array}{l} \text{FRM } \boxed{G_m} \\ \text{HD } \boxed{I_m} \end{array} \right] \right\rangle, \\ \text{SYN } \boxed{0} \\ \text{CRD } - \end{array} \right\rangle \\ \\ \left\langle \begin{array}{l} \text{DOM } \boxed{C} \left\langle \left[\text{SYN } \textit{cnj} \right] \right\rangle \oplus \left\langle \left[\begin{array}{l} \text{FRM } \boxed{F_1} \\ \text{HD } \boxed{H_1} \end{array} \right] \dots \left[\begin{array}{l} \text{FRM } \boxed{F_n} \\ \text{HD } \boxed{H_n} \end{array} \right] \right\rangle \oplus \\ \boxed{B_2} \text{ne-list} \oplus \boxed{D} \left\langle \left[\begin{array}{l} \text{FRM } \boxed{G_1} \\ \text{HD } \boxed{I_1} \end{array} \right] \dots \left[\begin{array}{l} \text{FRM } \boxed{G_m} \\ \text{HD } \boxed{I_m} \end{array} \right] \right\rangle \\ \text{SYN } \boxed{0} \\ \text{CRD } + \end{array} \right\rangle \end{array} \right] \\ \text{for } n, m \geq 0
 \end{array}$$

The domain of the mother begins with the (potentially empty) material \boxed{A} from the left conjunct, but the corresponding material in the right conjunct's DOM list is elided, i.e. not preserved in the mother's DOM list. The mother's DOM list next contains some unique material $\boxed{B_1}$ from the left conjunct, the right conjunct's coordinator, if present (\boxed{C}), some unique material $\boxed{B_2}$ from the right conjunct, and finally some material \boxed{D} from the right conjunct (where the corresponding domain elements from the end of the left conjunct's DOM list are elided). The various coordination types fall out as in (20): if \boxed{A} is the empty list, there is no ACC. If \boxed{D} is the empty list, there is no RNR. If both are empty, this is constituent coordination. Note that the left daughter is here required to be [CRD -]. This ensures that the left daughter is not itself marked for coordination, ruling out phrases like *[*and John*] [*and Mary*]. The mother's CRD value is unspecified, allowing it to be either a right daughter ([CRD +]) in a larger coordinate structure or else a free-standing *sign* ([CRD -]) which can also appear as a left daughter in a larger coordinate structure. This provides an account of contrasts like the following:

- (28) a. Jan [walks [talks and [chews gum]]].
 b. Jan [[walks and talks] [or [walks and [chews gum]]]].
 c. *Jan [walks [chews gum]].

Our use of the F(O)RM value ensures that elided elements involve the same morphological forms as their licensing counterparts. For example, homophonous words (e.g. *lie* 'speak falsely' vs. *lie* 'be in horizontal position') involve distinct forms but may have identical phonological realizations. We assume (following recent work by Penn 1999, Klein 2000, and Haji-Abdolhosseini 2003), that HPSG PHON values should exhibit internal organization, corresponding to hierarchical

prosodic structures. In the next section we discuss certain semantic issues in NCC, in particular the interpretation of elided quantifier phrases, taking as our departure point previous work by Crysmann (2003).

5 Semantic Constraints on NCC

Crysmann proposes a distinction between heads and dependents in ACC. On his approach, overt and elided heads do not share their semantics (i.e. their CONT values are not identified), since this would also unify argument information:

- (29) We gave Jan a record and Yo a book.

If *gave* and its elided counterpart were semantically identified, then the indices of their arguments would also be identified, incorrectly requiring (minimally) *Jan* to be coindexed with *Yo* and *a record* to be coindexed *a book*. However, Crysmann argues that semantics of dependents *must* be shared, based on data such as (30):

- (30) a. I gave few men a book on Friday and a record on Saturday.
b. \rightarrow I gave few men a book on Friday and I gave few men a record on Saturday. (Crysmann, 2003, (12))

The argument is that *few men* and its elided counterpart must share CONT values in order to capture these judgments, since this would ‘merge’ the quantifiers of the two NPs, and thus prevent interpretations with multiple quantifiers. But if the semantics of elided NPs *must* be merged with that of their nonelliptical licensors, then data such as (31) are not allowed:

- (31) a. Mary sent a letter to Bill on Friday and to Peter on Saturday.
b. ?A letter was posted from Gozo last Saturday and from Tunis this week. (Crysmann, 2003, (21))

Crysmann suggests that in (31), while the letters need not be physically identical, they must at least have identical content. But data such as (32) suggest otherwise:

- (32) a. Stanford sent a letter to Bill informing him he was accepted and to Jake informing him he was rejected.
b. They found a thesis topic for Jan on Sunday and for Yo on Wednesday.

The only possible interpretation of (32) is that the letters/thesis topics are altogether different. Non-identified readings are also possible in sentences like (33):

- (33) I gave a couple of books to Pat on Monday and to Sandy on Tuesday.

Here again the reading where Pat and Sandy received different books (with different contents) is acceptable, although the merged reading is also available (like-wise for (31)). Comparing this again to (30), it indeed appears that (30) is less acceptable than (32) and (33) on a disjoint quantifier reading. One could suppose that

monotone decreasing quantifiers prefer quantifier merger more than other quantifiers, although it is not clear why this should be the case. Regardless, a broader base of evidence than that examined by Crysmann suggests that independent quantification is in general an available option. Furthermore, in both ACC and RNR this optional identification is allowed only with quantifier phrases:

- (34) a. The waiter managed to evict the customers through the front door and the staff through the back door.
 b. [The waiter forced the customers] and [the manager persuaded the staff] to leave quietly.

In both examples, identification of the semantics of the elided infinitival VPs with that of the non-elided ones would lead to the same problems noted above regarding the semantic identification of heads. Thus we conclude that Crysmann's account of dependent semantics is too strong and should instead be only an option for quantifier phrases. We propose the constraint in (35):

(35) **Optional Quantifier Merger:**

For any elided phrase denoting a generalized quantifier in the domain of either conjunct, the semantics of that phrase may optionally be identified with the semantics of its non-elided counterpart.

This constraint is encoded into the *cnj-cxt* as shown in (36). Note that (36) is meant to be read in conjunction with (27); the \overline{P} s and \overline{Q} s range over the \overline{F} s, \overline{G} s, \overline{H} s, and \overline{I} s from (27) (we state these as separate AVMs for expository purposes):

(36) *cnj-cxt* \Rightarrow

$$\left[\begin{array}{l} \text{MTR} \mid \text{SEM} \mid \text{RELS } \overline{X}_1 \oplus \dots \oplus \overline{X}_i \oplus \overline{Y} \oplus \overline{Z} \\ \left. \begin{array}{l} \text{DOM} \left\langle \begin{array}{l} \text{FRM } \overline{P}^j \\ \text{HD } \overline{Q}^j \\ \text{SEM } \overline{S}_j \left[\begin{array}{l} \text{IND ref-index} \\ \text{RELS } \overline{X}_j \end{array} \right] \end{array} \right\rangle \dots \left. \begin{array}{l} \text{FRM } \overline{P}^i \\ \text{HD } \overline{Q}^i \\ \text{SEM } \overline{S}_i \left[\begin{array}{l} \text{IND ref-index} \\ \text{RELS } \overline{X}_i \end{array} \right] \end{array} \right\rangle \circ \text{ne-list} \\ \text{DTRS} \left\langle \begin{array}{l} \text{SEM} \mid \text{RELS } \overline{X}_1 \circ \dots \circ \overline{X}_m \circ \overline{Y} \\ \text{DOM} \left\langle \begin{array}{l} \text{FRM } \overline{P}^j \\ \text{HD } \overline{Q}^j \\ \text{SEM } \overline{S}_j \left[\begin{array}{l} \text{IND ref-index} \\ \text{RELS } \overline{X}_j \end{array} \right] \end{array} \right\rangle \dots \left. \begin{array}{l} \text{FRM } \overline{P}^i \\ \text{HD } \overline{Q}^i \\ \text{SEM } \overline{S}_i \left[\begin{array}{l} \text{IND ref-index} \\ \text{RELS } \overline{X}_i \end{array} \right] \end{array} \right\rangle \circ \text{ne-list} \\ \text{SEM} \mid \text{RELS } \overline{X}_1 \circ \dots \circ \overline{X}_i \circ \overline{Z} \end{array} \right. \end{array} \right]$$

where $\forall j, \langle \overline{P}^j, \overline{Q}^j \rangle \in \{ \langle \overline{F}_1, \overline{H}_1 \rangle, \dots, \langle \overline{F}_n, \overline{H}_n \rangle, \langle \overline{G}_1, \overline{I}_1 \rangle, \dots, \langle \overline{G}_m, \overline{I}_m \rangle \}$

In other words, among the elements that are elided (i.e. the elements which share a FRM and HD value with a previous constituent as in (27)), some subset

of these may also share their SEM values. The RELS list of the mother includes all non-identified material from the RELS lists of each conjunct plus one copy of the identified quantifiers. For convenience, we treat the combinatoric semantics of coordinate constructions in terms of the ancillary feature CONJ, whose value we will take to be a (maximally singleton) list of relations introduced by a coordinator lexeme. The relevant constraint is the following:

$$(37) \quad \text{conj-}cxt \Rightarrow \left[\begin{array}{l} \text{MTR} \quad \left[\begin{array}{l} \text{LTOP} \quad \boxed{0} \\ \text{CONJ} \quad \langle \boxed{2} \rangle \end{array} \right] \\ \text{DTRS} \quad \left\langle \left[\begin{array}{l} \text{LTOP} \quad \boxed{1} \end{array} \right], \left[\begin{array}{l} \text{LTOP} \quad \boxed{0} \\ \text{CONJ} \quad \langle \boxed{2} \text{JUNCTS} \boxed{1} \rangle \end{array} \right] \right\rangle \end{array} \right]$$

We are assuming that a conjunction is analyzed as a boolean relation that takes only one argument – its JUNCTS argument. This corresponds intuitively to the set of semantic objects that is the argument of an *and_rel* or *or_rel*. More precisely, the conjuncts, each of which has an LTOP (‘local top’) corresponding to its top-level semantics, are introduced one at a time, always on the left branch of a binary branching coordinate structure. The construction in (37) identifies the LTOP of each conjunct with the conjunction’s JUNCTS argument. From this it follows that the LTOPs of all the conjuncts are merged. Since handle merger in MRS is analogous to set formation, the resulting semantics correctly predicates *and_rel* or *or_rel* of the set that is the union of the semantics of all the conjuncts. Our analysis produces SEM values like the following:

$$(38) \quad \left[\begin{array}{l} \text{FORM} \quad \langle \text{walk, hop, and run} \rangle \\ \text{CRD} \quad - \\ \text{CONJ} \quad \langle \boxed{2} \rangle \\ \text{SEM} \quad \left[\begin{array}{l} \text{LTOP} \quad h_0 \\ \text{RELS} \quad \left\langle \left[\begin{array}{l} \text{walk_rel} \\ \text{LBL} \quad h_1 \\ \text{WALKER} \quad i \end{array} \right], \left[\begin{array}{l} \text{hop_rel} \\ \text{LBL} \quad h_1 \\ \text{HOPPER} \quad i \end{array} \right], \left[\begin{array}{l} \text{and_rel} \\ \text{LBL} \quad h_0 \\ \text{JUNCTS} \quad h_1 \end{array} \right], \left[\begin{array}{l} \text{run_rel} \\ \text{LBL} \quad h_1 \\ \text{RUNNER} \quad i \end{array} \right] \right\rangle \end{array} \right] \end{array} \right]$$

This AVM represents a conjunction over three separate predications of walking, hopping, and running, respectively.

6 Summative Agreement

We now turn briefly to the topic of agreement patterns in RNR. Yatabe (2002) discusses and analyzes examples like the following (due to Postal 1998):

- (39) The pilot claimed that the first nurse, and the sailor proved that the second nurse, **were** spies. (Yatabe, 2002, (2))

In these sentences the plural agreement on *were* is not predicted by an ellipsis-based account, which would predict that the overt copula should agree with the right-most subject (and likewise that the elided copula is singular as well). Following Yatabe, we refer to the phenomenon illustrated in (39) as summative agreement, since the copula appears to be agreeing with an aggregate entity composed of the two entities introduced by the overt singular subjects. Yatabe's work with native speaker informants reveals that such sentences are of intermediate acceptability (only 7 of the 23 subjects he studied found this sentence to be perfectly acceptable). Despite Postal's claims to the contrary, we assume (with Yatabe) that the corresponding example with a RNRed singular VP is fully grammatical:

- (40) The pilot claimed that the first nurse, and the sailor proved that the second nurse, **was** a spy.

Because he assumes examples such as (39) are grammatical, Yatabe presents an analysis with significantly complicated agreement constraints. We suggest instead that, while singular agreement as in (40) is always grammatical, summative agreement as in (39) is, strictly speaking, ungrammatical. It is instead explicable as a performance phenomenon, i.e. as a kind of semi-sentence (Katz, 1964; Pullum and Scholz, 2003). Performance-based plural agreement is in fact widely attested, as in the following examples:

- (41) a. One of the children **are** not feeling well.
 b. Every one of the guests **are** here
 c. The pump as well as the motor **are** defective.
 d. The helicopter for the flights over the canyon **were**....
 e. Filling in for Mike and John on the weekends **are** among Stan's favorite duties.
 f. First and foremost, work from both summers **are** to be presented at two international conferences in August of this year.

Solomon and Pearlmutter (to appear) explain the frequent occurrence of such examples in terms of **semantic integration**, the degree to which two elements (e.g. helicopters and flights) are linked at the 'message level' during production. We may interpret this as near-grammatical variants likely to arise in production due to incrementally constructed aggregate entities. Furthermore, a more systematic view of Yatabe's data reveals that the acceptability of summative agreement examples for his subjects varies depending to some degree on how pragmatically plausible it is to suppose the existence of an aggregate subject:

- (42) a. The pilot claimed that the first nurse, or the sailor proved that the second nurse, was a spy/?*were spies. [Disjunction]
 b. The pilot claimed that the nurse from the United States, and the sailor also claimed that the nurse from the United States, was a spy/?*were spies. [Coreferential subjects]

- c. The pilot claimed that the nurse from the United States, and the sailer claimed that no one, was a spy/?*were spies. [Negative quantifier] (Yatabe, 2001, (7)-(9))

For the examples in (42), Yatabe's subjects rated these sentences as consistently lower in acceptability than (39). Notably, however, in each case the possibility of forming an aggregate entity is confounded by pragmatic factors. Disjunctions as in (42a) in general disprefer aggregate readings, as would the coreferentiality of the two subjects in (42b) and the negative quantification in (42c), where there isn't necessarily a second entity to form an aggregate with the nurse from the United States. Thus one can argue that part of the licensing of summative agreement is pragmatic in nature. Putting these observations together, treating examples such as (39) and (41) as semi-sentences whose acceptability is based on performance factors such as local context (e.g. preceding plural NPs) and the possibilities of semantic integration explains their frequent occurrence and decreased acceptability. Thus the analysis of NCC we propose in §4-§5 needs no modification for summative coordination. It predicts, correctly we believe, that singular agreement is the only truly grammatical alternative, leaving the explanation of relatively less acceptable versions of summative agreement to extra-grammatical factors.⁵

7 Double Coordinators

One possible objection to an ellipsis-based analysis of NCC is the behavior of double coordinators, which appear inconsistent with treating ACC as VP or S coordination. The French data in (43) are particularly telling (Anne Abeillé, p.c.).

- (43) a. Jean donnera et un livre à Paul et un disque à Marie.
Jean give.FUT and a book to Paul and a record to Marie
'Jean will give a book to Paul and a record to Marie.'
- b. *Jean et donnera un livre à Paul et un disque à Marie.
Jean and give.FUT a book to Paul and a record to Marie
'Jean will give a book to Paul and a record to Marie.'
- c. *Et Jean donnera un livre à Paul et un disque à Marie.

Assuming that the coordinator must immediately precede the coordinated elements, this data suggests that the coordination is not VP or S coordination (otherwise we would expect the conjunction to appear before the verb in the left conjunct or else before the entire sentence). Note similar data in English (Bob Borsley, p.c.):

- (44) John gave either a book to Mary or a record to Sandy.

⁵One might propose a similar analysis of examples like *John hummed and Mary sang, the same tune*, first noted by Vergnaud (1974) (see also Jackendoff 1977). These longstanding problems for any theory of RNR share a number of the properties just discussed with respect to summative agreement. For example, the disjunctive *John hummed or Mary sang, the same tune* is seriously degraded.

These examples suggest that the overt verb is outside of the domain of coordination. However, an alternative generalization is that the first conjunction is marking the edge of non-elided material, i.e. it occurs canonically marking the boundaries between elided and non-elided material:

- (45) a. Jan [either **gave a book to Yo on Sunday**] [or **gave a record to Sandy on Friday**].
 b. Jan [gave_i either **a book to Yo on Sunday**] [\emptyset_i or **a record to Sandy on Friday**].
 c. Jan [gave_i a book_j either **to Yo on Sunday**] [\emptyset_i \emptyset_j or **to Sandy on Friday**].

In this case, the coordinators do not determine the edge of the domain of coordination. This is not an unreasonable assumption, since in fact in English (unlike French) the first coordinator may occur before the verb:

- (46) a. Jan [gave either **a book to Yo**] [or **a record to Sandy**].
 b. Jan [either gave **a book to Yo**] [or **a record to Sandy**].
 c. [Either Jan gave **a book to Yo**] [or **a record to Sandy**].

These data all follow if we assume that the first coordinator may optionally float to the left in English, but not in French. We thus have further evidence that conjunction position does not determine constituent structure, and on these grounds we assume that the data presented here do not speak against our analysis. In fact, they present a further challenge to any analysis in the style of CCG, which assumes that all instances of ACC are instances of constituent coordination.

8 Conclusion

A number of residual issues remain, of which we mention three here. First, there is the matter raised in §5 regarding the constraints on the application of optional quantifier merger. Assuming that quantifier merger is optional, our analysis (like most treatments of coordination) does not account for the apparent lack of ambiguity of well-worn examples like:

- (47) a. No book is explicit and easy to read.
 b. \nrightarrow No book is explicit and no book is easy to read.
 (48) a. Few people read the *WSJ* and vote Communist.
 b. \nrightarrow Few people read the *WSJ* and few people vote Communist.

In these data the subject NPs steadfastly resist interpretations with duplicate quantifiers, instead preferring quantifier merger. We tentatively suggest that this can be regarded simply as a preference for constituent coordination. This conclusion is supported by the observation that subject quantifier duplication is possible when more material is elided:

(49) ?A letter was posted from Gozo last Saturday and from Tunis this week.
(Crysmann, 2003, (21d))

(50) Three men died in Baghdad on Tuesday and in Tikrit on Friday night.

However, these data, along with those in §5 on the behavior of monotone decreasing quantifiers and quantifier merger, require more careful examination in future work.

Second, linearization-based approaches require that phrases must be allowed to remain uncompact (or at least partially uncompact), in order to permit long-distance RNR, e.g.:

(51) Merle knew the relatives wanted to visit, and Bo knew that we were going to have to let them visit, [Aunt and Uncle Leslie, who lived in Corsica].

The consequences of this also require further investigation.

Finally, as currently defined, the system we outline here also allows long-distance ACC like the following:

(52) ?We found a book that was about a Civil War hero on Monday and a WWI hero on Tuesday

The status of such examples is somewhat unclear, though it seems that they become acceptable with strong supporting contexts, such as the following:

(53) A: Were you successful last week in finding books about war heroes?
B: We found a book that was about a Civil War hero on Monday and a WWI hero on Tuesday

In sum, though there are unresolved issues, the approach presented here, incorporating key insights of Yatabe and Crysmann, divorces UDCs from coordination on syntactic and typological grounds. It also unifies three kinds of coordination (constituent coordination, RNR, ACC) into one overarching schema, with enough flexibility to state independent constraints on each kind. Our analysis clarifies previous accounts of the semantics of ACC and interacts with independently observed performance-based properties to accommodate summative agreement in RNR.

References

- Beavers, John. 2004. Type-inheritance Combinatory Categorical Grammar. In *Proceedings of COLING 2004*, Geneva.
- Borsley, Robert D. To appear. Against ConjP. *Linguistics*.
- Carpenter, Bob. 1992. Lexical and Unary Rules in Categorical Grammar. In Bob Levine (ed.), *Formal Grammar: Theory and Implementation*, Oxford University Press.

- Chung, Sandra. 1976. On the Subject of Two Passives in Indonesian. In Charles N. Li (ed.), *Subject and Topic*, pages 57–98, New York: Academic Press.
- Collins, Michael. 1996. A New Statistical Parser Based on Bigram Lexical Dependencies. In *Proceedings of the 34th Annual Meeting of the ACL*, Santa Cruz.
- Collins, Michael. 1997. Three Generative, Lexicalised Models for Statistical Parsing. In *Proceedings of the 35th Annual Meeting of the ACL*, Madrid.
- Crysmann, Berthold. 2003. An Asymmetric Theory of Peripheral Sharing in HPSG: Conjunction Reduction and Coordination of Unlikes. In *Formal Grammar 2003*, <http://cs.haifa.ac.il/~shuly/fg03/>.
- Davis, Anthony. 1992. Empty Heads and Missing Subjects: Underspecification in Hausa VPs. In *Proceedings of CLS 28*, University of Chicago.
- Dowty, David R. 1988. Type-raising, Functional Composition, and Nonconstituent Coordination. In Richard Oehrle, Emmon Bach and Dierdre Wheeler (eds.), *Categorial Grammars and Natural Language Structures*, pages 153–198, Dordrecht: Kluwer Academic Publishers.
- Haji-Abdolhosseini, Mohammad. 2003. A Constraint-Based Approach to Information Structure and Prosody Correspondence. In Stefan Müller (ed.), *Proceedings of the 2003 HPSG Conference*, Stanford, CA: CSLI Publications.
- Hockenmaier, Julia. 2003. *Data and Models for Statistical Parsing with Combinatory Categorial Grammar*. Ph. D.thesis, School of Informatics, the University of Edinburgh, Edinburgh.
- Jackendoff, Ray. 1977. *X̄ Syntax: A Study of Phrase Structure*. Cambridge, MA: MIT Press.
- Katz, Jerrold J. 1964. Semi-sentences. In Jerrold Fodor and Jerrold J. Katz (eds.), *The Structure of Language*, Englewood Cliffs, NJ: Prentice Hall.
- Klein, Ewan. 2000. Prosodic Constituency in HPSG. In Ronnie Cann, Claire Grover and Philip Miller (eds.), *Grammatical Interfaces in HPSG*, pages 169–200, Stanford, CA: CSLI Publications.
- Kluender, Robert. 1992. Deriving Island Constraints from Principles of Predication. In Helen Goodluck and Michael Rochemont (eds.), *Island Constraints: Theory, Acquisition, and Processing*, pages 223–258, Dordrecht: Kluwer Academic Publishers.
- Koutsoudas, Andreas. 1971. Gapping. *Foundations of Language* 7(3), 337–386.
- Maxwell III, John T. and Manning, Christopher D. 1996. A Theory of Non-Constituent Coordination Based on Finite-State Rules. In Miriam Butt and Tracy Holloway King (eds.), *Proceedings of the First LFG Conference*, Stanford, CA: CSLI Publications.
- Milward, David. 1994. Non-Constituent Coordination: Theory and Practice. In *Proceedings of COLING 1994*, Kyoto.
- Munn, Alan. 2000. Three Types of Coordination Asymmetries. In Kerstin Schwabe and Ning Zhang (eds.), *Ellipsis in Conjunction*, pages 1–22, Tübingen: Niemeyer.
- Newman, Paul. 2000. *The Hausa Language*. New Haven: Yale University Press.
- Penn, Gerald. 1999. An RSRL Formalization of Serbo-Croatian Second Posi-

- tion Clitic Placement. In Valia Kordoni (ed.), *Tübingen Studies in Head-Driven Phrase Structure Grammar, No. 132*, pages 177–197, Universität Tübingen.
- Pollard, Carl and Sag, Ivan A. 1994. *Head-Driven Phrase Structure Grammar*. Chicago, IL: The University of Chicago.
- Postal, Paul. 1998. *Three Investigations of Extraction*. Cambridge, MA: MIT Press.
- Pullum, Geoffrey K. and Scholz, Barbara. 2003. Foundations of Model-Theoretic Syntax. Vienna: ESSLLI, <http://www.folli.uva.nl/CD/2003/Foundational/PullumScholz/Pullum-Scholz.pdf>.
- Reape, Michael. 1994. Domain Union and Word Order Variation in German. In John Nerbonne, Klaus Netter and Carl Pollard (eds.), *German Grammar in HPSG*, pages 151–197, Stanford: CSLI Publications.
- Sag, Ivan A. 2001. Dimensions of Locality in Natural Language. Invited Presentation, 2001 HPSG Conference, NTNU, Trondheim, Norway.
- Sag, Ivan A. 2002. Coordination and Underspecification. In Jong-Bok Kim and Stephen Wechsler (eds.), *Proceedings of the 2002 HPSG Conference*, Stanford, CA: CSLI Publications.
- Sag, Ivan A., Gazdar, Gerald, Wasow, Thomas and Weisler, Steven. 1985. Coordination and How to Distinguish Categories. *Natural Language and Linguistic Theory* (3), 117–171.
- Sag, Ivan A., Wasow, Thomas and Bender, Emily. 2003. *Syntactic Theory: A Formal Introduction*. Stanford, CA: CSLI Publications, second edition.
- Steedman, Mark. 1989. Constituency and Coordination in Combinatory Grammar. In Mark Baltin and Anthony Kroch (eds.), *Alternative Conceptions of Phrase Structure*, Chicago: University of Chicago Press.
- Steedman, Mark. 1996. *Surface Structure and Interpretation*. Cambridge, Mass: MIT Press.
- Steedman, Mark. 2000. *The Syntactic Process*. Cambridge, Mass: MIT Press.
- Vergnaud, Jean-Roger. 1974. *French Relative Clauses*. Ph. D.thesis, MIT.
- Wexler, Kenneth and Culicover, Peter. 1980. *Formal Principles of Language Acquisition*. Cambridge, MA: MIT Press.
- Yatabe, Shûichi. 2001. The Syntax and Semantics of Left-Node Raising in Japanese. In Daniel Flickinger and Andreas Kathol (eds.), *Proceedings of the 2001 HPSG Conference*, Stanford, CA: CSLI Publications.
- Yatabe, Shûichi. 2002. A Linearization-Based Theory of Summative Agreement in Peripheral-Node Raising Constructions. In Jong-Bok Kim and Stephen Wechsler (eds.), *Proceedings of the 2002 HPSG Conference*, Stanford, CA: CSLI Publications.
- Yatabe, Shûichi. 2004. A Comprehensive Theory of Coordination of Unlikes. In Stefan Müller (ed.), *Proceedings of the 2004 HPSG Conference*, Stanford, CA: CSLI Publications.

An approach to English comparative correlatives

Robert D. Borsley 

University of Essex

Proceedings of the 11th International Conference on
Head-Driven Phrase Structure Grammar

Center for Computational Linguistics, Katholieke Universiteit Leuven

Stefan Müller (Editor)

2004

Stanford, CA: CSLI Publications

pages 70–92

Borsley, Robert D. 2004. An approach to English comparative correlatives. In Stefan Müller (ed.), *Proceedings of the 11th International Conference on Head-Driven Phrase Structure Grammar*, Center for Computational Linguistics, Katholieke Universiteit Leuven, 70–92. Stanford, CA: CSLI Publications. DOI: 10.21248/hpsg.2004.4.



Abstract

Recent syntactic theory has highlighted the importance of peripheral constructions such as the comparative correlative construction. This construction involves a pair of filler-gap constructions with unusual properties, where the first is a subordinate clause and the second a main clause. The construction has a number of related constructions. A version of HPSG, which assumes hierarchies of phrase types, can provide satisfactory analyses both for the comparative correlative construction and for the related constructions. The two clauses in the construction can be analysed as non-standard head-filler phrases differing from standard head-filler phrases in certain respects. The construction as a whole can be analyzed as a non-standard head-adjunct phrase, in which the head and the phrase have different categories.

1. Introduction

A notable feature of recent work in syntactic theory is a new interest in the periphery of language.[†] Particularly important here is the detailed discussion in Culicover (1999). Culicover emphasizes the size of the periphery and argues that there is ‘a continuum along which a full spectrum of possibilities can be found, from very idiosyncratic to very general’ (1999: vi). If this is right, it is not possible for theories of syntax to ignore peripheral constructions. Rather, they must find ways of accommodating them, and how well a framework can accommodate such constructions is potentially an important matter. As Fodor (2001) notes, it is reasonable to suppose that peripheral constructions may help to choose between theories of syntax. Therefore, it is important to consider what sorts of analyses various theoretical frameworks can provide for such constructions.

In this paper I will look at one specific peripheral construction, the comparative correlative (CC) construction (also known as the comparative conditional construction), discussed *inter alia* by Ross (1967, 6.1.2.6), McCawley (1988) and Culicover and Jackendoff (1999). (1) is a typical example.

(1) The more books I read, the more I understand.

I will argue that HPSG and especially the version of HPSG developed in Ginzburg and Sag (2000) can provide a fairly straightforward account of the facts.

[†] Some of the ideas in this paper were included in a paper presented at the Spring Meeting of the Linguistics Association of Great Britain at the University of Sheffield in April 2003 and in another presented at FASL-12 at the University of Ottawa in May 2003. I have benefited from comments from and/or discussion with Anne Abeillé, Doug Arnold, John Beavers, Peter Culicover, Danièle Godard, Claudia Felser, Gereon Müller, Adam Przepiórkowski, Andrew Radford, Ivan Sag, Peter Sells and Nick Sobin. Any bad bits are my responsibility.

The fact that the framework can provide a satisfactory account of this one construction might be seen as not very significant. However, it is likely that HPSG could accommodate the other constructions discussed by Culicover (1999) equally well. Thus, there may be some important evidence here for HPSG.

2. Data and basic conclusions

The CC construction apparently contains two clausal constituents, each with an initial constituent containing *the* and a comparative word of some kind. In other words, it seems to have the following form:

(2) [[*the* comparative ...] ...] [[*the* comparative ...] ...]

I will call the clauses *the*-clauses and the initial constituents *the*-phrases. I will look first at the structure of the clauses and then consider the relation between them. Then I will look at some related constructions.

2.1. *The*-clauses

The first point to note about *the*-clauses is that *the*-phrases can be a number of categories. In the first clause in (1) the *the*-phrase is an NP. It can also be an AP, as in (3), or an AdvP, as in (4).

- (3) The more careful we are, the more we will find.
- (4) The more carefully we look, the more we will find.

Within HPSG assumptions it is doubtful whether either *the* or *more* is the head of the phrase in (1), (3) and (4). Consider also the following:

- (5) The more hostages' stories I hear, the more confused I am.

This seems to have an interpretation in which *the more hostages'* is a possessive modifier of *stories*. On this interpretation, neither *the* nor *more* is the head of the whole initial constituent within any framework.

Culicover and Jackendoff (1999: 559) note that correlative *the* cannot be preceded by a pied piped preposition. Thus, while (6a) is fine, (6b) is ungrammatical.

- (6) a. The more people Kim talks to, ...
- b. *To the more people Kim talks, ...

This contrasts with the situation in *wh*-questions, as the following illustrate:

- (7) a. How many people did Kim talk to?
- b. To how many people did Kim talk?

The ungrammaticality of (6b) might lead one to think that *the*-clauses do not allow a PP in initial position. However, as Andrew Radford has pointed out to me, this is what we seem to have in the following examples:

- (8) a. The more out of breath I am, ...
b. The more under the weather he is, ...

It seems that the real restriction is that *the* must appear in first position within the *the*-phrase.¹ Independent evidence for this comes from the following:

- (9) a. The more politicians I read articles about, ...
b. *Articles about the more politicians I read, ...

Here both examples have an NP in initial position but only (9a) has *the* in first position within the NP.

The-phrases are associated with a gap. This may be in complement position, as in the first clause of (1) and (3), adjunct position, as in the first clause of (4), or subject position, as in the following:

- (10) The more books they think are written, ...

Both Ross (1967) and Culicover and Jackendoff (1999) show that the relation between the *the*-phrase and the gap obeys island constraints. It seems, then, that the two clauses are filler-gap constructions broadly similar to *wh*-interrogatives, exclamatives and *wh*-relatives. However, they are different in some respects.

One unusual feature of *the*-clauses, noted by Culicover and Jackendoff (1999: 546), is the possibility of *that* after the *the*-phrase, illustrated by (11).

- (11) The more books that I read, the more that I understand.

This is unlike the situation in *wh*-interrogatives, exclamatives and relative clauses, as the following show:

- (12) a. I wonder how much (*that) he read.
b. I am surprised how smart (*that) he is.
c. the books which (*that) he read

Since Chomsky and Lasnik (1977) a great deal of effort has been devoted to explaining why a filler constituent cannot be followed by an overt complementizer in English. Examples like those in (12) show that this is normally impossible, but examples like (11) show that it is not always impossible.²

¹ This idea was originally suggested to me by Peter Sells.

² Another type of example in which a filler constituent appears to be followed by an overt complementizer is exemplified by the bracketed constituent in the following:

- (i) [Clever though Kim is], he couldn't solve the problem.

Another unusual feature of *the*-clauses, highlighted by Culicover and Jackendoff (1999: 554), is that they allow the omission of a copula under certain circumstances. It seems that it is possible to omit the copula if: (a) its complement is fronted, (b) it is the main verb of the construction, and (c) *that* is not present. All three conditions are met in (13), but (14a) violates the first, (14b) and (14c) violate the second, and (14d) violates the third.

- (13) The more intelligent the students, the better the marks.
(14) a. *The more intelligent the students, the more marks given.
b. *The more intelligent the students, the better the marks will.
c. *The more intelligent the students, the better it seems that the marks.
d. *The more intelligent that the students, the better that the marks.

The subject must also have a non-specific interpretation. Among other things, this means that it may not be a pronoun, as (15) demonstrates.

- (15) *The more intelligent they, the more pleased we.

Obviously, it is not normally possible to omit the copula even if it is a main verb and its complement is fronted. Hence the following are ungrammatical:

- (16) a. *The students very intelligent.
b. *How intelligent the students?

It seems, then, that the *the*-clauses are filler-gap constructions with some unusual properties. These properties are one reason why the construction might be seen as peripheral.

2.2. The relation between the two clauses

The CC construction contains two similar clauses. There is evidence, however, that the first clause is a subordinate clause and the second a main clause.

Culicover and Jackendoff (1999: 549-550) show that the second clause influences and reflects the external environment of the construction in ways that suggest that it is a main clause. First, it is possible to have a tag question which reflects the second clause but not one which reflects the first clause.

- (21) The more we eat, the angrier you get, don't you?
(22) *The more we eat, the angrier you get, don't we?

Second, in the right context, the verb in the second clause may have subjunctive morphology, but this is not possible with the verb in the first clause.

Here *clever* appears to be a filler constituent and *though* appears to be a complementizer. I am grateful to Danièle Godard for bringing such examples to my attention.

- (23) $\left\{ \begin{array}{l} \text{It is imperative that} \\ \text{I demand that} \end{array} \right\} \left\{ \begin{array}{l} \text{the more John eats, the more he pay} \\ \text{* the more John eat, the more he pays} \end{array} \right\}$

Culicover and Jackendoff also note (1999: 559) that subject-auxiliary inversion is possible in the second clause but not the first. Thus, (24a) seems acceptable, but not (24b).

- (24) a. ?The more Bill smokes, the more does Susan hate him.
 b. *The more does Bill smoke, the more Susan hates him.

Given that subject-auxiliary inversion does not normally occur in subordinate clauses but occurs in various types of main clause, this seems to provide further evidence that the first clause is a subordinate clause and the second a main clause.

It seems, then, that the CC construction consists of a subordinate clause and a main clause. However, the subordinate clause is obligatory although it is not a complement of some lexical head. Hence, (25) is not possible.

- (25) *The more I understand.

On the other hand, it cannot appear with an ‘ordinary’ main clause.

- (26) a. *The more books I read, I understand philosophy.
 b. *The more books I read, I go to sleep.
 c. *The more books I read, it’s a nice day.

This is another reason why one might see the construction as peripheral.

2.3. Related constructions

There are a number of constructions with which the CC construction shares certain properties. One is what McCawley (1988) calls the reversed CC construction, exemplified by the following:

- (27) I understand more, the more I read.

Here the second clause is a *the*-clause and the first clause contains a bare in-situ comparative element. The first clause can vary in form in ways that show clearly that it is a main clause. The following illustrate:

- (28) I expect him to understand more, the more he reads.
 (29) I am impressed by his understanding more, the more he reads.
 (30) Does he understand more, the more he reads?
 (31) How much more does he understand, the more he reads?

An important fact about this construction, noted by McCawley (1988), is that the main clause need not contain a comparative element.³ All that is required is that it has a certain kind of comparative semantics. Thus, (32) and (33) are acceptable, but not (34)

- (32) My knowledge increases, the more I read.
- (33) My grades improve, the more I work.
- (34) *My grades are good, the more I work

Unlike in the CC construction, the main clause can appear without the subordinate clause, as (35) shows.

- (35) I understand more.

Notice, however, that this has a broader range of interpretations than when it appears in the reversed construction. (35) can mean ‘I understand more than X’, where X is some individual given by the context, whereas the main clause in (27) can only mean something like ‘I understand more than previously’. Thus, while (36) is fine, (37) is very odd.

- (36) Kim understands a lot, but I understand more.
- (37) *Kim understands a lot, but I understand more, the more I read

The reversed construction seems to be simpler than the standard CC construction. It is quite like various constructions in which a main clause combines with an adjunct clause. All that is special about it is that the main clause is required to have a certain kind of semantics and the subordinate clause cannot be ‘fronted’, as (38) shows.

- (38) *The more I read, I understand more.

More like the CC construction in some ways are the *if-then* construction, also highlighted by McCawley (1988), and the *as-so* construction, highlighted by den Dikken (2003). The following illustrate:

- (39) If I read more, then I understand more.
- (40) As I read more, so I understand more.

In both cases it is fairly clear that the first clause is a subordinate clause, but in both cases this clause is obligatory although it is not a complement of some lexical head. Thus, the following are not possible unless *then* and *so* have some different interpretation:

- (42) *Then I understand more.
- (42) *So I understand more.

³ In earlier work, e.g. Borsley (2004), I assumed that the main clause must contain a comparative element and used the feature that I use to handle *the*-phrases for this purpose.

Both constructions have simpler related constructions, as the following illustrate:

- (43) I understand more if I read more.
 (44) I understand more as I read more.

These are quite like the reversed CC construction. The subordinate clauses are optional adjuncts like the *the*-clause in reversed construction. However, unlike a *the*-clause they can be fronted, as the following show:

- (45) If I read more, I understand more.
 (46) As I read more, I understand more.

To summarize, it seems that we have three constructions, which we might call correlative clauses, and that each has a related construction, in which a main clause combines with an adjunct clause. Thus, we have the following situation:

Correlative clause	S + adjunct construction
Standard CC construction	Reversed CC construction
<i>If-then</i> construction	S + <i>if</i> -clause
<i>As-so</i> construction	S + <i>as</i> -clause

This classification suggests that the term ‘reversed CC construction’ is not an ideal one. However, I will continue to use it.

3. An HPSG analysis

I will now show that it is not too difficult to provide an analysis of the standard CC construction and the related constructions within the version of HPSG developed in Ginzburg and Sag (2000), in which grammars include hierarchies of phrase types, subject to various constraints. I will look first at *the*-clauses and then consider the CC construction and the related constructions as a whole.

3.1. *The*-clauses

A satisfactory analysis of *the*-clauses requires an analysis of *the*-phrases, so I will consider *the*-phrases first.

The-phrases are rather like *wh*-phrases, but whereas *wh*-phrases are required to contain just one element, a *wh*-word, *the*-phrases are required to contain two elements, *the* and a comparative word. A NONLOCAL feature ensures that a *wh*-phrase contains a *wh*-word. An obvious approach to *the*-phrases is to use a NONLOCAL feature to ensure that one of the necessary elements appears and to let this element require the appearance of the other. To implement this idea I will assume that correlative *the* and constituents that are required to contain it have the value *the* for a NONLOCAL feature FILLERFORM (FFORM for short) and that

all other constituents have the value *none* for this feature.⁴ Some languages have two different elements corresponding to *the*. One example is Polish, which has examples like the following:

- (47) Im więcej książek czytam, tym więcej rozumiem.
IM more books I-read TYM more I-understand
'The more books I read, the more I understand.'

In such a language FFORM will have two values apart from *none*. The evidence that FFORM is a NONLOCAL feature is not strong. However, some motivation for this assumption comes from the fact that speakers do not generally allow an in-situ *the*-phrase. If FFORM is a NONLOCAL feature, filler and gap will not have the same value for FFORM, and we can say that non-filler positions are [FFORM *none*], thus excluding an in-situ *the*-phrase. There is an alternative view of FFORM that one might consider. Some work in HPSG, e.g. Tseng (2003), has employed EDGE features, which always appear at the edge of a phrase. FFORM behaves like an EDGE feature when it has the value *the*. However, there is at least one language, Polish, where FFORM cannot be an EDGE feature. Polish has sentences in which a counterpart of English *the* is not in initial position, for example the following:

- (48) Z im dawniejszych epok pochodzi próbka badana tą
from IM earlier epochs comes sample investigated this.INS
metoda, tym błąd jest większy.
method.INS TYM error is greater
'The earlier the origin of the sample examined by this method, the greater is the error.'

I will assume, then, that FFORM is a NONLOCAL feature subject to a special linear precedence (LP) constraint, formulated below, when it has the value *the*.

If *the*-phrases are [FFORM *the*] and correlative *the* is the only word that is [FFORM *the*], *the*-phrases will necessarily contain correlative *the*. To ensure that they also contain a comparative word of some kind we can assume that correlative *the* can only appear as a specifier of a comparative word. Given these assumptions, the *the*-phrase in (1) will have something like the following structure:

⁴ In earlier work, e.g. Borsley (2004), I used the name CORREL for this feature. It now seems better to me to use this name for a feature which distinguishes *the*-clauses from other sorts of clauses.

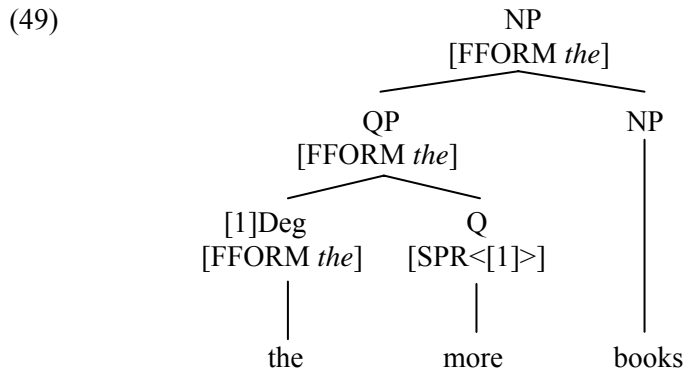

To allow such phrases, we will need a lexical description like that in (50) for *the*, and lexical descriptions of the form in (51) for a comparative word which combines with *the*.

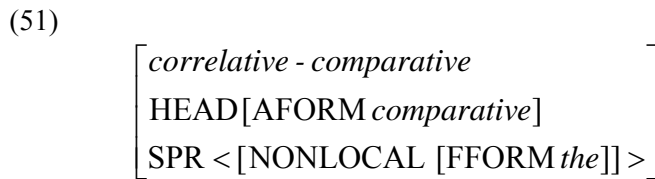
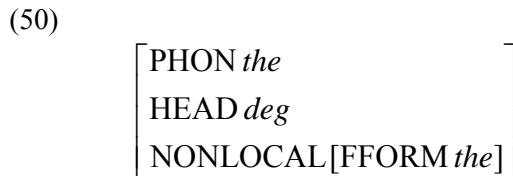

An ordinary comparative word will have a rather different lexical description, not allowing a specifier but allowing a *than* phrase or clause. The two descriptions can be analyzed as different ways of fleshing out a basic, partially specified lexical description, and only the latter need appear in the lexicon.

We can now consider *the*-clauses. One thing we need is some feature specification to distinguish such clauses from all other types of clause. As I will show below, we cannot use the feature specification which identifies *the*-phrases for this purpose. Therefore we need some other feature specification. It is in fact standard within HPSG for filler-gap constructions to be identified by a different feature specification from that which identifies their filler constituent. Thus, in Ginzburg and Sag's (2000) analysis, *wh*-interrogatives are identified by their semantic properties while their fillers are identified by the WH feature. Similarly, in Sag's (1997) analysis, relative clauses are identified by having a certain value for MOD but when they contain a filler it is identified by the REL feature. It seems unlikely that *the*-clauses can be distinguished by their semantic properties or by the value of MOD. At least some *the*-clauses will presumably have a value for the MOD feature which indicates that they modify a clause with what we might call an implicit comparison interpretation. However, other sorts of adjunct

clause will have the same value for MOD when they modify a clause with the relevant semantic properties. The *if*-clause in (43) is a relevant example. I will assume, therefore, that *the*-clauses, and also *if*-, *then*-, *as*-, and *so*-clauses, are identified by an appropriate value for a CORREL(ative) feature. (Other sorts of clause will be [CORREL *none*].) Assuming this feature, we can propose the following structure for the subordinate *the*-clause in (1):

(52)

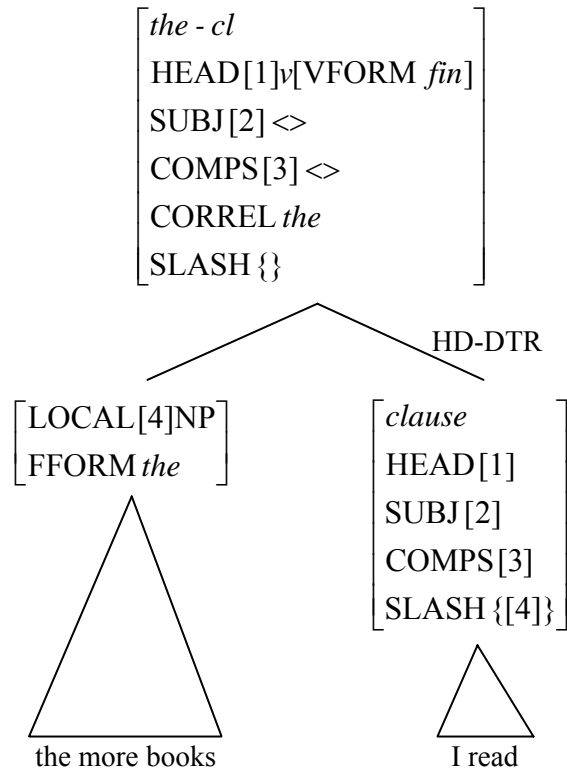

Here and subsequently, I ignore the fact that all the features are part of the value of CATEGORY and the fact that FFORM and SLASH are part of the value of NONLOCAL. I am also ignoring the possibility that the clause should have a MOD feature, something to which I return. The main *the*-clause in (1) will have essentially the same structure. For the subordinate *the*-clause in (11), we can propose the structure in (53). This is identical to (52) except that the value of HEAD in the phrase and its head is *c*[VFORM *fin*] rather than *v*[VFORM *fin*].

(53)

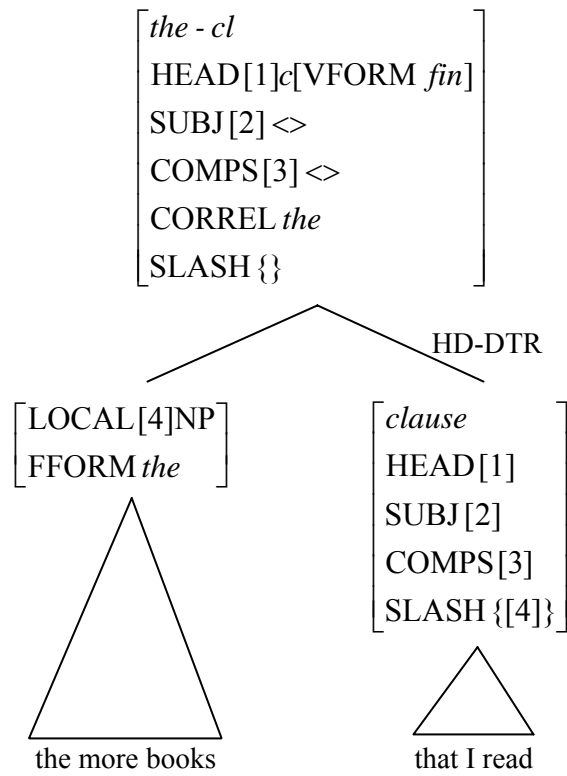

These are complex structures, but their various properties can be attributed to a small number of constraints.

Before we can present the necessary constraints, we need some phrase types. I will assume the following:

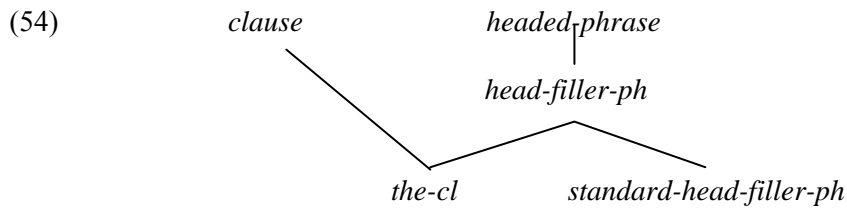

This indicates that a *the*-clause is both a clause and a head-filler-phrase, the latter being one type of headed phrase. It also indicates that a standard-head-filler-phrase is another type of head-filler phrase.

The first constraint that we need is the following:

(55)

$$clause \rightarrow \left[\begin{array}{l} \text{HEAD } verbal \\ \text{SUBJ } list(noncanon - ss) \\ \text{COMPS } \langle \rangle \end{array} \right]$$

This ensures that a clause is a verbal constituent which is either ‘saturated’, i.e. contains a full set of dependents, or has an unexpressed subject. Following Ginzburg and Sag (2000: 24), *verbal* is a type with the subtypes *verb* and *c* (complementizer). *Verb* in turn has the subtypes *v* (pure verb) and *g* (gerund). Thus we have the following situation:

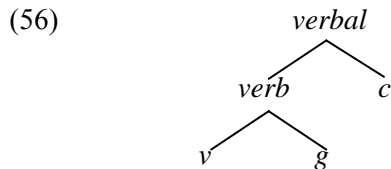

Given this, it follows from (55) that a clause may be headed by a pure verb, a gerund or a complementizer. In (52) we have a *the*-clause headed by a pure verb and in (53) we have a *the*-clause headed by a complementizer.

(55) accounts for some basic properties of (52) and (53). Some others are accounted for by the Generalized Head Feature Principle of Ginzburg and Sag (2000: 33), which we can formulate as follows:

(57)

$$hd-ph \rightarrow \left[\begin{array}{l} \text{SYNSEM} / [1] \\ \text{HD - DTR} [\text{SYNSEM} / [1]] \end{array} \right]$$

This is a default statement, as indicated by the slash notation. It requires a headed phrase and its head-daughter to have the same syntactic and semantic properties unless some other constraint requires a difference.

The differences between the phrase and its head daughter in (52) and (53) are a consequence of the following constraint:

(58)

$$head-filler-ph \rightarrow \left[\begin{array}{l} \text{SLASH} \{ \} \\ \text{DTRS} < [\text{LOC} [1]], [2] \left[\begin{array}{l} \textit{phrase} \\ \text{SLASH} \{ [1] \} \end{array} \right] > \\ \text{HD - DTR} [2] \end{array} \right]$$

This ensures that a head-filler-phrase is SLASH {} and has a head daughter which is a phrase and a non-head daughter, whose LOCAL value is the local feature structure within the value of SLASH on the head daughter. It accounts for some of the main properties of (52) and (53). (58) imposes no constraints on the HEAD value of the head daughter. Hence, it may be a complementizer-headed phrase, as in (53). Obviously, most head-filler constructions cannot be headed by a complementizer. We can assume that this is because they are instances of the type *standard head-filler-phrase*, which is subject to the following constraint:

(59) *standard-head-filler-ph* \rightarrow [HD-DTR [HEAD *v*]]

This requires a standard-head-filler-phrase to have a head-daughter which is [HEAD *v*]. It accounts for the impossibility of *that* in the examples in (12).

The main distinctive properties of English *the*-clauses can be accounted for by the following constraint:

(60)

$$the-cl \rightarrow \left[\begin{array}{l} \text{HEAD}[\text{VFORM } fin] \\ \text{CORREL } the \\ \text{DTRS} \langle [\text{FFORM } the], [] \rangle \end{array} \right]$$

This ensures that a *the*-clause is finite, is [CORREL *the*] and has a non-head daughter which is [FFORM *the*]. One consequence of this constraint is that a *the*-clause cannot be a gerund.

We need one further constraint to ensure that *the* appears in first position in the initial constituent. We can propose the following informal LP constraint here:

(61) [FFORM *the*] < [FFORM *none*]

I have not included [FFORM *none*] in any of the trees that I have presented above, but I assume that constituents which are not correlative *the* or required to contain correlative *the* are [FFORM *none*]. The ungrammatical examples in (6b) and (9b) both contain a [FFORM *none*] constituent before a [FFORM *the*] constituent. Hence they violate this constraint. A consequence of the constraint is that we cannot use [FFORM *the*] to identify *the*-clauses. If *the*-clauses were marked as [FFORM *the*], the reversed construction would violate the constraint.

We have now accounted for the properties of *the*-clauses. They have some properties because they are clauses, some because they are headed phrases, some because they are head-filler-phrases, some because they are *the*-clauses, and some because they contain a [FFORM *the*] constituent. Most of their properties are shared with other constructions of one kind or another. Only those embodied in (60) and (61) are specific to *the*-clauses.

3.2. The constructions

We can now consider the constructions as a whole. We suggested at the end of section 2 that the standard CC construction is one of three correlative constructions, each of which has a related S + adjunct construction. I will look first at the latter and then consider the former.

An S + adjunct construction is one type of head-adjunct-phrase, in which an adjunct combines with an expression of some kind to form a larger expression of the same kind. If we assume that what kind of expression an adjunct combines with is encoded by the MOD feature, (24) will have something like the following structure:

(62)

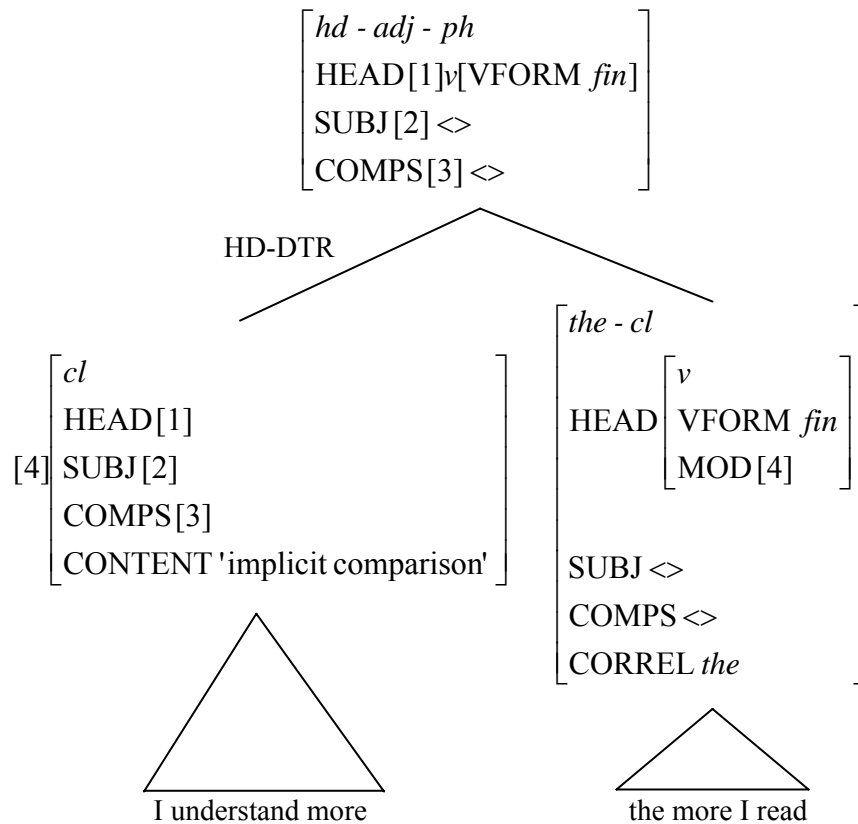

Given such structures, a *the*-clause must be able to have an appropriate value for the MOD feature, which I will represent as 'S[imp-comp]'. I will assume that *the*-clauses which are non-heads have this value but that a *the*-clause which is a head is [MOD *none*]. This means that the constraint in (60) must be replaced by something like the following:

(63)

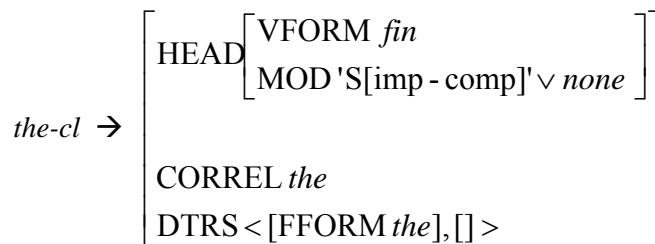

Whereas *the*-clauses combine with a clause with certain semantic properties, *if*-clauses and *as*-clauses combine with more or less any clause. It follows that they will have a MOD feature which does not restrict the CONTENT of the clause with which they combine. They will also have different values for CORREL, *if* and *as*, respectively. (43) will have something like the following structure:

(64)

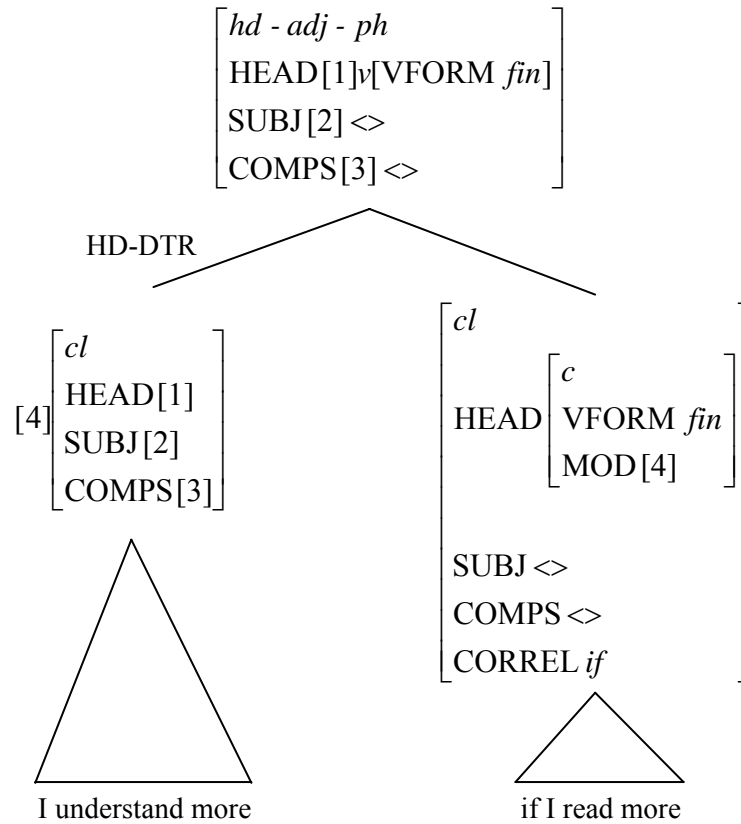

(44) will have a similar structure. I assume that the MOD and CORREL features of *if*- and *as*-clauses are inherited from *if* and *as*, respectively, which are presumably complementizers. If this is right, there is no need for any special phrase types here.

These analyses require appropriate restrictions on head-adjunct-phrases. We can assume something like the following constraint:

(65)

$$hd-adj-ph \rightarrow \left[\begin{array}{l}
 DTRS \langle [1][SS[2]], [HEAD[MOD[2]]] \rangle \\
 HD - DTR [1]
 \end{array} \right]$$

This poses no restrictions on the phrase itself, only on its daughters. It follows from the Generalized Head Feature Principle that head-adjunct phrases are the same type of phrase as their head. It follows from this that this type of phrase must be licensed in other positions and hence that adjuncts are optional. As we have seen, this is the case in the three S + adjunct constructions.

We noted in 2.3 that the *the*-clause in the reversed CC construction cannot be fronted. We can ensure this with the following LP constraint:

$$(66) [DTRS \langle [1][CORREL \textit{none}], [2][CORREL \textit{the}] \rangle] \rightarrow [1] \langle [2]$$

We can now consider the correlative constructions. They differ from the corresponding S + adjunct constructions in that the main clause has some distinctive marking and cannot appear on its own. I assume that the distinctive marking is a reflection of the value of CORREL and that this is why these clauses cannot appear on their own. I assume that the constructions are [CORREL *none*] like most clauses. Thus, what we have here are non-standard head-adjunct-phrases, in which the phrase and its head differ in certain respects. Given these assumptions, (1) will have something like the following structure:

(67)

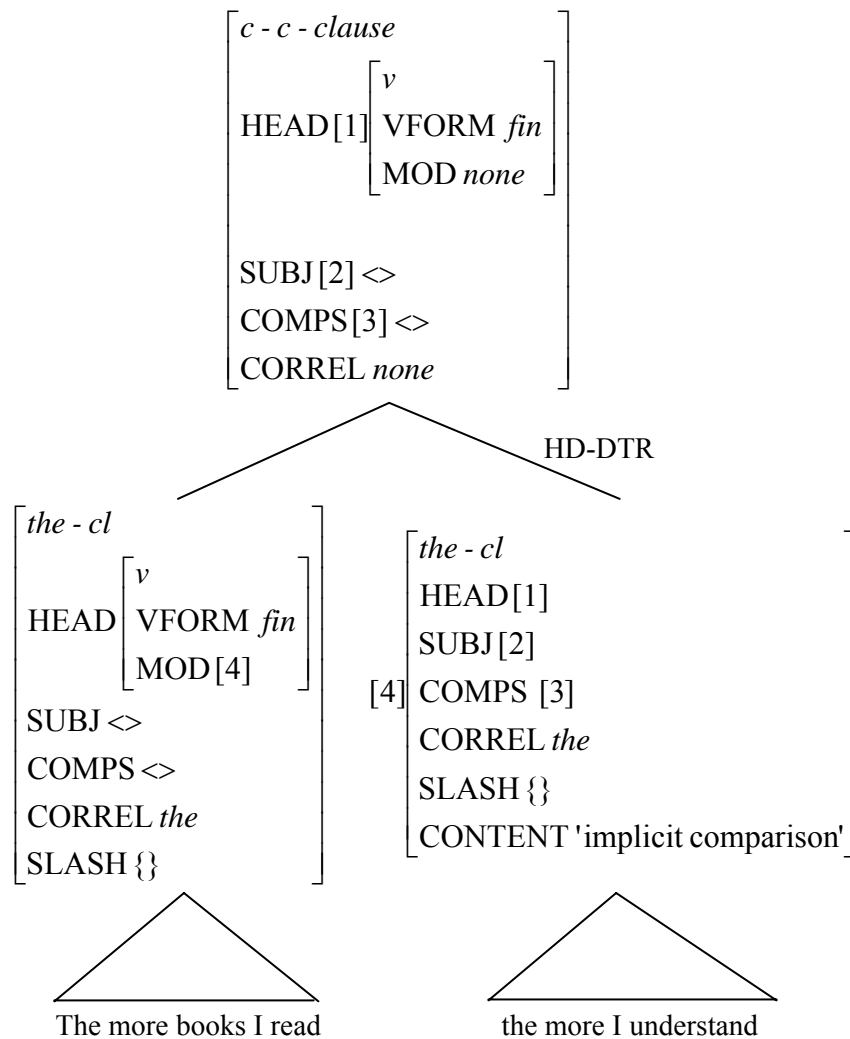

For the *if-then* construction we can propose the structure in (68).

(68)

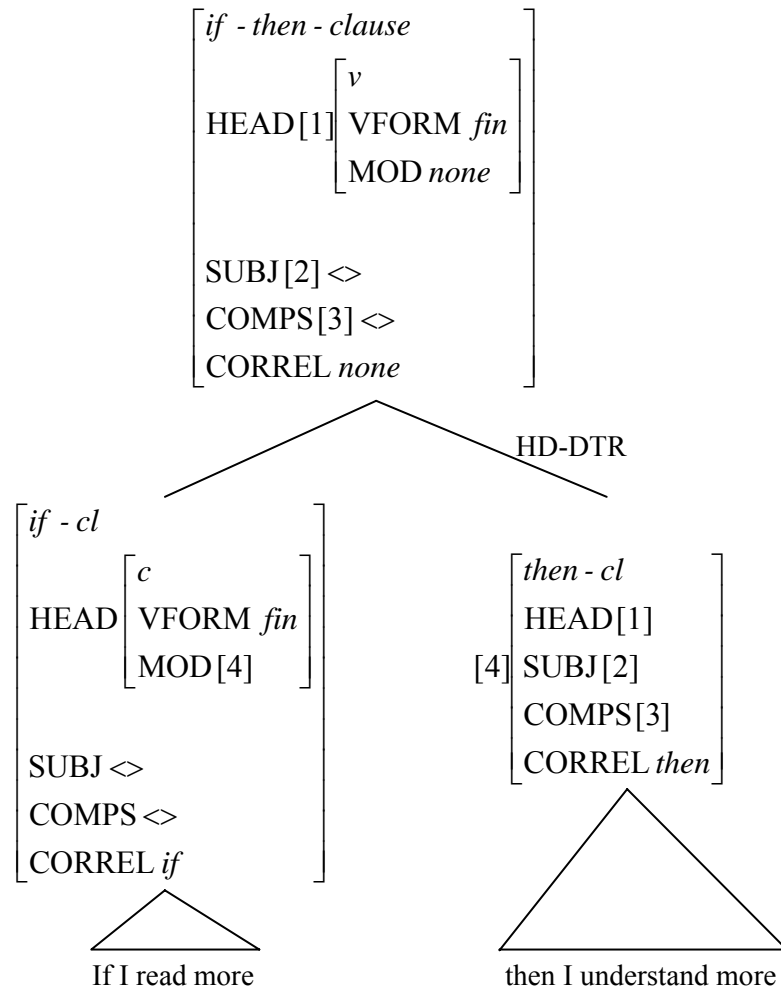

The *as-so* construction will have a very similar structure. I will not try to decide what the internal structure of *then-* and *so-*clauses is.⁵

To provide an account of the constructions, we need some further phrase types as follows:

⁵ One complication, brought to my attention by Anne Abeillé, is that *then-*clauses are relatively unconstrained. For example, they can be both interrogatives and imperatives.

- (i) If you see Kim, then what will you say?
- (ii) If you see Kim, then ask him about the project.

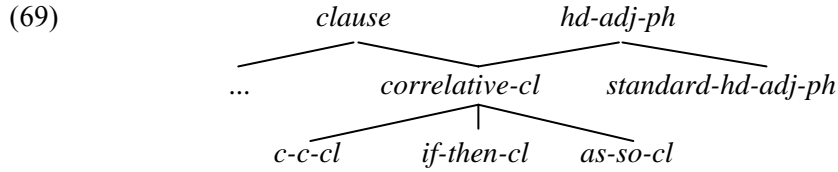

Here we have a type *correlative-clause*, which is a subtype of *clause* and *head-adjunct-phrase* and has the subtypes *c-c-clause*, *if-then-clause* and *as-so-clause*. We also have a type *standard-head-adjunct-phrase*.

Again, various properties of the constructions follow from (55) and (57). Others follow from the following constraint:

(70)

$$\text{correlative-cl} \rightarrow \left[\begin{array}{l} \text{HEAD } \nu \\ \text{CORREL } \textit{none} \\ \text{DTRS } \langle [1][\text{MOD } \textit{none}], [] \rangle \\ \text{HD - DTR } [1] \end{array} \right]$$

This ensures that a correlative clause is [HEAD ν] and [CORREL *none*], and has a head daughter, which is [MOD *none*], and a non-head daughter. It is fairly clear that we must require the construction to be [CORREL *none*] and the head to be [MOD *none*], but one might wonder if the [HEAD ν] stipulation is necessary. However, in an example like (11) the head daughter is [HEAD *c*], but the construction should presumably be [HEAD ν]. If this is right, the [HEAD ν] stipulation is necessary.

We can account for the distinctive properties of the three subtypes of correlative-clause with the following constraints:

- (71) a. *c-c-cl* \rightarrow [DTRS \langle [CORREL *the*], [CORREL *the*] \rangle]
 b. *if-then-cl* \rightarrow [DTRS \langle [CORREL *then*], [CORREL *if*] \rangle]
 c. *as-so-cl* \rightarrow [DTRS \langle [CORREL *so*], [CORREL *as*] \rangle]

We also need to ensure that the main clause comes second in these constructions. Here we can propose the following constraint:

(72) [DTRS \langle [1][CORREL \neg *none*], [2][CORREL \neg *none*] \rangle] \rightarrow [2] \langle [1]

This ensures that where two sisters have a value other than *none* for the feature CORREL, the non-head comes first.

We saw in 2.2 that, it is possible to have a tag question which reflects the second clause of the CC construction but not the first clause and that in the right context, the verb in the second clause but not the verb in the first clause may have subjunctive morphology. These facts follow from the fact that the second clause is the head with the same syntactic and semantic properties as the construction except where some constraint requires a difference.

We also saw in 2.2 that subject-auxiliary inversion is possible in a main *the*-clause. If we don't say anything special, it will be possible. We need, however, to say something to prevent subject-auxiliary inversion in subordinate *the*-clauses. We can propose the following constraint here:

$$(73) \quad \left[\begin{array}{l} \textit{the-cl} \\ \text{MOD} \neg \textit{none} \end{array} \right] \rightarrow [\text{INV} -]$$

Notice that we cannot say that subject-auxiliary inversion is impossible in all adjunct clauses given the possibility of counterfactual conditionals like that in (74)

(74) Had he been there, we would have seen him.

What about the other clauses that we are concerned with here? If *if* and *as* are complementizers, there is no need to specify a value for INV on *if*-clauses and *as*-clauses. Whether it is necessary to mark the *then* and *so* clauses as [INV -] will depend on how *then* and *so* are analysed, a matter which I am not considering here.

I suggested earlier that the main clause in a correlative construction cannot appear on its own because of the value it has for the CORREL feature. The idea here is that root clauses are [CORREL *none*]. In fact with the exception of the adjunct position in a head-adjunct-phrase and the two daughters in a correlative-clause all clausal positions must be [CORREL *none*]. I will not try to decide how this restriction should be imposed, but as long as it is imposed, it will be impossible for the main clause in a correlative construction to appear on its own.

We now have an account of the main properties of the standard CC construction and the other correlative constructions. They have some properties because they are clauses and headed phrases, some because they are correlative-clauses, some because they are one of the subtypes of correlative-clause, and some because of the daughters they contain. Only the constraints in (71a) and (73) are specific to the standard CC construction.

3.3. Copula omission

We must now consider how copula-omission might be accommodated. I will suggest that it is the result of the special properties of one verb, *be*, and one construction, the head-filler-phrase.

I propose that head-filler phrases but not other types of phrase can have a null head and that only *be* has a phonologically null form. Assuming that phonologically null forms are [NULL +], we can propose the lexical description in (75) for the null form of *be*, which will give structure in (76) for the first clause in (13).

(75)

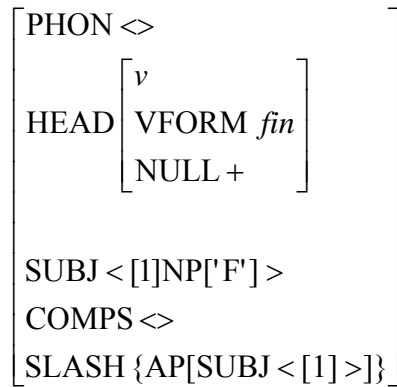

(76)

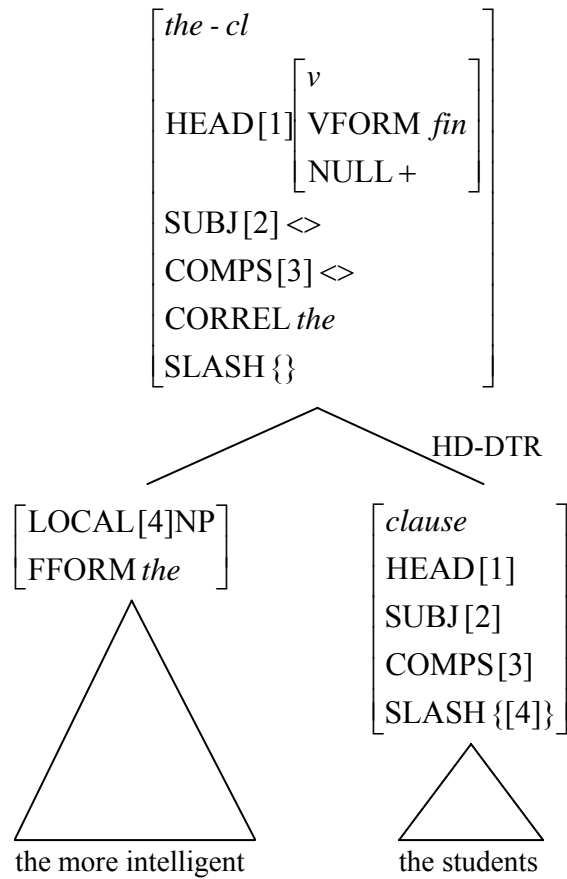

I use 'F' here to stand for whatever restrictions need to be placed on the subject. The important features of (75) are the [NULL +] feature, the COMPS feature, which ensures that this form does not have an in-situ complement, and the

SLASH feature, which ensures that it has a fronted complement.⁶ (76) is just like (52) except that the construction and hence its head is [NULL +]. Assuming that only head-filler-phrases can have a null head, the ungrammatical examples in (14) are ruled out. In (14a) the null copula has an in-situ complement, which is not allowed by (75). In (14b), (14c) and (14d) the null copula is not the head of a head-filler-phrase. In (14b) *will* is the head of the head-filler-phrase, in (14c) *seems* is, and in (14d) *that* is.

5. Concluding remarks

In this paper I have provided an HPSG analysis of the CC construction and related constructions. I have treated *the*-clauses as non-standard head-filler phrases, similar in some ways to standard head-filler-phrases but with some distinctive properties, and I have treated the standard CC construction as a non-standard head-adjunct-phrase, similar in some ways to standard head-adjunct-phrases but with some distinctive properties. The analysis captures both the distinctive properties of the construction and the properties it shares with other constructions. This is not really surprising, given that hierarchies of phrase-types are designed to allow constraints of any level of generality from the very general to the very specific. Thus, they can accommodate the peculiar properties of peripheral constructions without missing generalizations. It seems likely that they will be able to accommodate other peripheral phenomena equally well. There may well be some important support for HPSG here.

References

- Borsley, Robert D. 2004. On the periphery: Comparative correlatives in Polish and English. In *Proceedings of Formal Approaches to Slavic Linguistics* 12.
- Chomsky, Noam and Lasnik, Howard 1977. Filters and control. *Linguistic Inquiry* 8: 425-504.
- Culicover, Peter W. 1999. *Syntactic Nuts: Hard Cases, Syntactic Theory and Language Acquisition*. Oxford: Oxford University Press.
- Culicover, Peter W. and Jackendoff, Ray S. 1999. The view from the periphery: The English comparative correlative. *Linguistic Inquiry* 30: 543-571.
- Dikken, Marcel den. 2003. Comparative correlatives comparatively. Unpublished paper, CUNY (<http://web.gc.cuny.edu/dept/lingu/dendikken/papers.html>).

⁶ The null copula is not the only English verb that does not allow an in-situ complement. Another is illustrated by the following:

- (i) a. What he may do is go home
- b. * He may do go home
- (ii) a. What he is doing is going home
- b. * He is doing going home

- Fodor, Janet Dean. 2001. Parameters and the periphery: Reflections on *Syntactic Nuts*. *Journal of Linguistics* 37: 367-392.
- Ginzburg, Jonathan and Sag, Ivan A. 2000. *Interrogative Investigations: The Form, Meaning and Use of English Interrogatives*. Stanford: CSLI Publications.
- McCawley, James D. 1988. The comparative conditional construction in English, German and Chinese. In *Proceedings of the Fourteenth Annual Meeting of the Berkeley Linguistics Society*, 176-187.
- Ross, John Robert. 1967. *Constraints on Variables in Syntax*. Ph.D. dissertation, MIT.
- Sag, Ivan A. 1997. English relative clauses. *Journal of Linguistics* 33, 431-483.
- Tseng, Jesse. 2003. EDGE features and French liaison. In *Proceedings of the 9th International Conference on Head-Driven Phrase Structure Grammar*, 313-33.

GIDL_P: A grammar format for linearization-based HPSG

Michael W. Daniels

Ohio State University

W. Detmar Meurers 

Ohio State University

Proceedings of the 11th International Conference on
Head-Driven Phrase Structure Grammar

Center for Computational Linguistics, Katholieke Universiteit Leuven

Stefan Müller (Editor)

2004

Stanford, CA: CSLI Publications

pages 93–111

Daniels, Michael W. & W. Detmar Meurers. 2004. GIDL_P: A grammar format for linearization-based HPSG. In Stefan Müller (ed.), *Proceedings of the 11th International Conference on Head-Driven Phrase Structure Grammar, Center for Computational Linguistics, Katholieke Universiteit Leuven*, 93–111. Stanford, CA: CSLI Publications. DOI: 10.21248/hpsg.2004.5. 

Abstract

Linearization-based HPSG theories are widely used for analyzing languages with relatively free constituent order. This paper introduces the Generalized ID/LP (GIDL) grammar format, which supports a direct encoding of such theories, and discusses key aspects of a parser that makes use of the dominance, precedence, and linearization domain information explicitly encoded in this grammar format. We show that GIDL grammars avoid the explosion in the number of rules required under a traditional phrase structure analysis of free constituent order. As a result, GIDL grammars support more modular and compact grammar encodings and require fewer edges in parsing.

1 Introduction

Within the framework of Head-Driven Phrase Structure Grammar (HPSG), the so-called linearization-based approaches have argued that constraints on word order are best captured within domains that extend beyond the local tree. A range of analyses for languages with relatively free constituent order have been developed on this basis (see, for example, Reape 1993; Kathol 1995; Müller 1999a; Donohue and Sag 1999; Bonami et al. 1999) so that it is attractive to exploit these approaches for processing languages with relatively free constituent order.

This paper introduces a grammar format that supports a direct encoding of linearization-based HPSG theories. The Generalized ID/LP (GIDL) format explicitly encodes the dominance, precedence, and linearization domain information and thereby supports the development of efficient parsing algorithm making use of this information. We make this concrete by discussing key aspects of a parser for GIDL grammars that integrates the word order domains and constraints into the parsing process.

2 Linearization-based HPSG

The idea of discontinuous constituency was first introduced into HPSG in a series of papers by Mike Reape (see Reape 1993, and references therein).¹ The core idea is that word order is determined not at the level of the local tree, but at the newly introduced level of an *order domain*, which can include elements from several local trees. We interpret this in the following way: Each terminal has a corresponding

*This paper includes material from (Daniels and Meurers 2004). The authors would like to thank Stefan Müller and the anonymous reviewers for HPSG04 and COLING04, as well as the HPSG04 and COLING04 audiences for advice and helpful comments.

¹Apart from Reape's approach, there have been proposals for a more complete separation of word order and syntactic structure in HPSG (see, for example, Richter and Sailer 2001; Penn 1999), an option outside the scope of this paper.

order domain, and just as constituents combine to form larger constituents, so do their order domains combine to form larger order domains.

Following Reape, a daughter's order domain enters its mother's order domain in one of two ways. The first possibility, *domain union*, forms the mother's order domain by shuffling together its daughters' domains. The second option, *domain compaction*, inserts a daughter's order domain into its mother's. Compaction has two effects:

- **Contiguity:** The terminal yield of a compacted category contains all and only the terminal yield of the nodes it dominates; there are no holes or additional strings.
- **LP Locality:** Precedence statements only constrain the order among elements within the same compacted domain. In other words, precedence constraints cannot look into a compacted domain.

Note that these are two distinct functions of domain compaction: defining a domain as covering a contiguous stretch of terminals is in principle independent of defining a domain of elements for LP constraints to apply to. In linearization-based HPSG, domain compaction encodes both aspects.

Later work (Kathol and Pollard 1995; Kathol 1995; Yatabe 1996) introduced the notion of *partial compaction*, in which only a portion of the daughter's order domain is compacted; the remaining elements are domain unioned.

3 Processing linearization-based HPSG

Formally, a theory in the HPSG architecture consists of a set of constraints on the data structures introduced in the signature. As such, word order domains are just additional structures, and the constraints on word order domains are no different from constraints on any other structure, and so the incorporation of linearization into a linguistic theory creates no formal difficulties. On the computational side, however, most systems employ parsers to efficiently process HPSG-based grammars organized around a phrase structure backbone. Phrase structure rules encode immediate dominance (ID) and linear precedence (LP) information in local trees, so they cannot directly encode linearization-based HPSG, which posits word order domains that can extend the local trees.

The ID/LP grammar format (Gazdar et al. 1985) was introduced to separate immediate dominance from linear precedence, and several proposals have been made for direct parsing of ID/LP grammars (see, for example, Shieber 1984). However, the domain in which word order is determined still is the local tree licensed by an ID rule, which is insufficient for a direct encoding of linearization-based HPSG.

The LSL grammar format as defined by Suhre (1999) (based on (Götz and Penn 1997)) allows elements to be ordered in domains that are larger than a local tree; as a result, categories are not required to cover contiguous strings. Linear precedence

constraints, however, remain restricted to local trees: elements that are linearized in a word order domain larger than their local tree cannot be constrained. The approach thus provides valuable worst-case complexity results, but it is inadequate for encoding linearization-based HPSG theories, which crucially rely on the possibility to express linear precedence constraints on the elements within a word order domain.

In sum, no grammar format is currently available that adequately supports the encoding of a processing backbone for linearization-based HPSG grammars. As a result, implementations of linearization-based HPSG grammars have taken one of two options. Some simply do not use a parser, such as the work based on Control (Götz and Meurers 1997); as a consequence, the efficiency and termination properties of parsers do not (automatically) transfer to such approaches.

The other approaches use a minimal parser that can only take advantage of a small subset of the requisite constraints. Such parsers are typically limited to the general concept of resource sensitivity – every element in the input needs to be found exactly once – and the ability to require certain categories to dominate a contiguous segment of the input. Some of these approaches (Johnson 1985; Reape 1991) lack word order constraints altogether. Others (van Noord 1991; Ramsay 1999) have the grammar writer provide a combinatory predicate (such as concatenate, shuffle, or head-wrap) for each rule specifying how the string coverage of the mother is determined from the string coverages of the daughter. In either case, the task of constructing a word order domain and enforcing word order constraints in that domain is left out of the parsing algorithm; as a result, constraints on word order domains either cannot be stated or are tested in a separate clean-up phase following the generate-and-test paradigm.

4 Defining GIDL P Grammars

To develop a grammar format for linearization-based HPSG, we take the syntax of ID/LP rules and augment it with a means for specifying which daughters form compacted domains. A Generalized ID/LP (GIDL P) grammar consists of four parts: a start declaration, a set of lexical entries, a set of grammar rules, and a set of global order constraints. We begin by describing the first three parts, which are reminiscent of context-free grammars (CFGs), and then address order constraints in section 4.1.²

- The **start declaration** has the form $start(S, L)$ and states the start symbol S of the grammar and any linear precedence constraints L constraining the start domain.

²We base the discussion in this paper on simple term categories; nothing hinges on this, and when using the formalism to encode linearization-based HPSG grammars, one will naturally use the feature descriptions known from HPSG as categories.

- **Lexical entries** have the form $A \rightarrow t$ and link the pre-terminal A to the terminal t , just as in CFGs.
- **Grammar rules** have the form $A \rightarrow \alpha; C$. They specify that a non-terminal A immediately dominates a list of non-terminals α in a domain where a set of order constraints C holds.
- **Global LP constraints**, as described in section 4.1.1.
- **Global compaction statements**, as described in section 4.1.2.

Note that in contrast to CFG rules, the order of the elements in α does not encode immediate precedence or otherwise contribute to the denotational meaning of the rule. Instead, the order can be used to generalize the head marking used in grammars for head-driven parsing (Kay 1990; van Noord 1991) by additionally ordering the non-head daughters; this is discussed further in section 6.

If the set of order constraints is empty, we obtain the simplest type of rule, exemplified in (1).

(1) $S \rightarrow NP, VP$

This rule says that an S may immediately dominate an NP and a VP , with no constraints on the relative ordering of NP and VP . If no other rule in the grammar imposes additional constraints, the lexical material dominated by NP may appear before, after, or intermingled with the material dominated by VP ; material from other constituents not dominated by S may also intervene.

4.1 Order Constraints

GIDL grammar include two types of order constraints: LP constraints and compaction statements.

4.1.1 Linear Precedence Constraints

All LP constraints enforce the intuitive idea that any instance of the LHS of the constraint must precede any instance of the RHS within the same context: individual rules (as *rule-level* constraints) or word order domains (as *domain-level* constraints). Domain-level constraints can also be specified as *global* order constraints, which has the effect that they are specified for each single domain.

The formal definition of precedence is as follows: consider all pairs of elements in a context where the first completely precedes the second. If any of these pairs jointly matches³ the pair description $\langle B, A \rangle$, the constraint is violated.⁴

³The precise definition of ‘match’ will depend on the nature of A and B . For instance, matching involves an identity test when categories are atomic and a subsumption test when categories are feature structures.

⁴This definition is due to (Kasper et al. 1995) and is intended to deal with cases where the nature of the match between the first element and A will influence whether or not the second element matches B , and vice versa.

LP constraints may optionally require that there be no intervening material between the two elements: this is referred to as immediate precedence. LP constraints are notated as follows:

- **Weak precedence:** $A < B$.
- **Immediate precedence:** $A \ll B$.

The symbols A and B may be *descriptions* or *tokens*. A constraint involving descriptions applies to any pair of elements in any domain in which the described categories occur; it thus can also apply more than once within a given rule or domain. Tokens, on the other hand, can only occur in rule-level constraints and refer to particular RHS members of a rule. In this paper, tokens are represented by numbers referring to the subscripted indices on the RHS categories.

In (2) we see an example of a rule-level linear precedence constraint.

$$(2) A \rightarrow NP_1, V_2, NP_3; 3 < V$$

This constraint specifies that the token 3 in the rule's RHS (the second *NP*) must precede any constituents described as V occurring in the same domain (this includes, but is not limited to, the V introduced by the rule).

4.1.2 Compaction Statements

As with LP constraints, compaction statements exist as rule-level and as global order constraints; they cannot, however, occur within other compaction statements. A rule-level compaction statement has the form $\langle \alpha, A, L \rangle$, where α is a list of tokens, A is the category representing the compacted domain, and L is a list of domain-level precedence constraints. Such a statement specifies that the constituents referenced in α form a compacted domain with category A , inside of which the order constraints in L hold. As specified in section 2, a compacted domain must be contiguous (contain all and only the terminal yield of the elements in that domain), and it constitutes a local domain for LP statements.

It is because of partial compaction that the second component A in a compaction statement is needed. If only one constituent is compacted, the resulting domain will be of the same category; but when multiple categories are fused in partial compaction, the category of the resulting domain needs to be determined so that LP constraints can refer to it.

The rule in (3) illustrates compaction: each of the S categories forms its own domain. In (4) partial compaction is illustrated: the V and the first NP form a domain named VP to the exclusion of the second NP .

$$(3) S \rightarrow S_1, \text{Conj}_2, S_3; 1 \ll 2, 2 \ll 3, \langle [1], S, \langle [] \rangle \rangle, \langle [3], S, \langle [] \rangle \rangle$$

$$(4) VP \rightarrow V_1, NP_2, NP_3; \langle [1, 2], VP, \langle [] \rangle \rangle$$

One will often compact only a single category without adding domain-specific LP constraints, so we introduce the abbreviatory notation of writing such a compacted category in square brackets. In this way (3) can be written as (5).

(5) $S \rightarrow [S_1], \text{Conj}_2, [S_3]; 1 \ll 2, 2 \ll 3$

A final abbreviatory device is useful when the entire RHS of a rule forms a single domain, which Suhre (1999) refers to as “left isolation”. This is denoted by using the token 0 in the compaction statement if linear precedence constraints are attached, or by enclosing the LHS category in square brackets, otherwise. (See rules (23d) and (23j) in section 8 for an example of this notation.)

The formalism also supports *global compaction statements*. A global compaction statement has the form $\langle A, L \rangle$, where A is a description specifying a category that always forms a compacted domain, and L is a list of domain-level precedence constraints applying to the compacted domain.

4.2 Examples

We start with an example illustrating how a CFG rule is encoded in GIDL format. A CFG rule encodes the fact that each element of the RHS immediately precedes the next, and that the mother category dominates a contiguous string. The context-free rule in (6) is therefore equivalent to the GIDL rule shown in (7).

(6) $S \rightarrow \text{Nom V Acc}$

(7) $[S] \rightarrow V_1, \text{Nom}_2, \text{Acc}_3; 2 \ll 1, 1 \ll 3$

In (8) we see a more interesting example of a GIDL grammar.

- (8)
- a) start($A, []$)
 - b) $A \rightarrow B_1, C_2, [D_3]; 2 < 3$
 - c) $B \rightarrow F_1, G_2, E_3$
 - d) $C \rightarrow E_1, D_2, I_3; \langle [1,2], H, \langle [] \rangle \rangle$
 - e) $D \rightarrow J_1, K_2$
 - f) Lexical entries: $E \rightarrow e, \dots$
 - g) $E < F$

(8a) is the start declaration, stating that an input string must parse as an A ; the empty list shows that no LP constraints are specifically declared for this domain. (8b) is a grammar rule stating that an A may immediately dominate a B , a C , and a D ; it further states that the second constituent must precede the third and that the third is a compacted domain. (8c) gives a rule for B : it dominates an F , a G , and an E , in no particular order. (8d) is the rule for C , illustrating partial compaction: its first two constituents jointly form a compacted domain, which is given the name H . (8e) gives the rule for D and (8f) specifies the lexical entries (here, the preterminals

just rewrite to the respective lowercase terminal). Finally, (8g) introduces a global LP constraint requiring an E to precede an F whenever both elements occur in the same domain.

Now consider licensing the string **efjekgikj** with the above grammar. The parse tree, recording which rules are applied, is shown in (9). Given that the domains in which word order is determined can be larger than the local trees, we see crossing branches where discontinuous constituents are licensed.

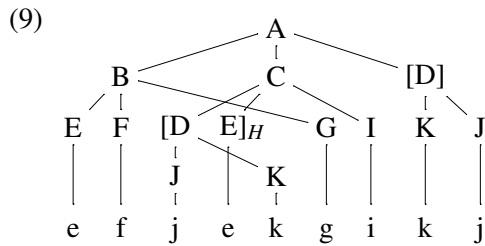

To obtain a representation in which the order domains are represented as local trees again, we can draw a tree with the compacted domains forming the nodes, as shown in (10).

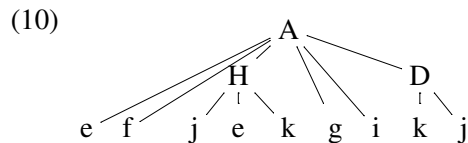

There are three non-lexical compacted domains in the tree in (9): the start A , the compacted D , and the partial compaction of D and E forming the domain H within C . In each domain, the global LP constraint $E < F$ must be obeyed. Note that the string is licensed by this grammar even though the second occurrence of E does not precede the F . This E is inside a compacted domain and therefore is not in the same domain as the F , so that the LP constraint does not apply to those two elements. This illustrates the property of LP locality: domain compaction acts as a ‘barrier’ to LP application.

The second aspect of domain compaction, contiguity, is also illustrated by the example, in connection with the difference between total and partial compaction. The compaction of D specified in (8b) requires that the material it dominates be a contiguous segment of the input. In contrast, the partial compaction of the first two RHS categories in rule (8d) requires that the material dominated by D and E , taken together, be a continuous segment. This allows the second e to occur between the two categories dominated by D .

Finally, the two tree representations above illustrate the separation of the combinatorial potential of rules (9) from the flatter word order domains (10) that the GIDL format achieves. It would, of course, be possible to write phrase structure rules that license the word order domain tree in (10) directly, but this would amount to replacing a set of general rules with a much greater number of flatter

rules corresponding to the set of all possible ways in which the original rules could be combined without introducing domain compaction. Müller (2004) discusses the combinatorial explosion of rules that results for an analysis of German if one wants to flatten the trees in this way. If recursive rules such as adjunction are included – which is necessary since adjuncts and complements can be freely intermixed in the German Mittelfeld – such flattening will not even lead to a finite number of rules. We will return to this issue in section 8.

4.3 The Formal Definition of a GIDL Grammar

The formal definition of a GIDL grammar arises from the intuition behind the formal definition of a context-free grammar:

A *context-free grammar* G is a quadruple (V, Σ, R, S) , where V is an alphabet, Σ (the set of *terminals*) is a subset of V , R (the set of *rules*) is a finite subset of $(V - \Sigma) \times V^*$, and S (the *start symbol*) is an element of $V - \Sigma$. The members of $V - \Sigma$ are called *nonterminals*. For any $A \in V - \Sigma$ and $u \in V^*$, we write $A \rightarrow_G u$ whenever $(A, u) \in R$. For any strings $u, v \in V^*$, we write $u \Rightarrow_G v$ if and only if there are strings $x, y \in V^*$ and $A \in V - \Sigma$ such that $u = xAy$, $v = xv'y$, and $A \rightarrow_G v'$. The relation \Rightarrow_G^* is the reflexive, transitive closure of \Rightarrow_G . Finally, $L(G)$, the *language generated by G* , is $\{w \in \Sigma^* : S \Rightarrow_G^* w\}$; we also say that G *generates* each string in $L(G)$ (Lewis and Papadimitriou 1998).

In particular, just as a context-free derivation is expressed as a series of strings over the corresponding alphabet, a GIDL derivation will need to be expressed in terms of a series of domain objects that may contain categories and other domain objects.

A **GIDL grammar** is a quintuple $\langle T, N, R, L, G \rangle$ where T is a set of terminals, N is a set of nonterminal categories,⁵ R is the start domain object (defined below), L a relation from $T \rightarrow N$ (the lexicon), and G a set of grammar rules (the grammar).

A **grammar rule** is a triple $\langle A, \alpha, C \rangle$ where $A \in N$ is the left-hand side category of the rule, α is a string of category-token pairs $\langle a, b \rangle$, where $a \in N$ and $b \in \mathbb{N}$, and/or domain objects (the right-hand side of the rule), and C is a set of LP constraints.

A **domain object** is a triple $\langle A, \alpha, C \rangle$ where $A \in N$ is the result category of the domain, α is a string of nonterminals and/or domain objects, and C is a set of LP constraints.

An **LP constraint** is a triple $\langle a, b, t \rangle$ where $a, b \in (N \cup \mathbb{N})$ and $t \in \{w, i\}$ (representing weak and immediate precedence, respectively). Such an LP constraint is **satisfied** by a domain object when, for all pairs of distinct domain elements x, y such that x precedes y , it must be the case that x, y does not match the pair description b, a . In addition, if $t = i$, then for all pairs of distinct domain elements x, y

⁵The definitions in this section are intended to be independent of the nature of the elements of N ; the only requirement is that the operation of pairwise-matching is defined. This allows the definitions to work with both atomic categories and feature structure categories.

such that x does not immediately precede y , it must be the case that x, y does not match the pair description a, b .

Now let A be the domain object $\langle a, \alpha A \beta, C_d \rangle$ and A' the domain object $A' = \langle a, \gamma, C_d \rangle$. If there is a rule $r \in G$ such that $r = \langle A, \delta, C_r \rangle$ and γ is a permutation of $\alpha \cdot \delta \cdot \beta$ such that, for all $c \in (C_d \cup C_r)$, γ satisfies c , then we say that $A \Rightarrow A'$ (read **A derives A' in one step**). In effect, γ represents a valid insertion of δ into $\alpha\beta$.

The transitive closure of \Rightarrow is denoted \Rightarrow^* ; when $A \Rightarrow^* A'$, we say **A derives A'** , and A' is derived from A . Finally, let a **preterminal string** s of a terminal string t with length n be a string of length n such that for all $0 \leq i < n$, $\langle t_i, s_i \rangle \in L$. Then a string of terminals is **recognized** by a grammar if there exists a corresponding preterminal string that can be derived from the start domain object of the grammar.

As an example, the grammar in (8) is formally described in (11) (for clarity, rule RHSs are given in terms of categories only instead of category-token pairs).

(11)

$$\begin{aligned}
T &= \{e, f, g, i, j, k\} \\
N &= \{A, B, C, D, E, F, G, H, I, J, K\} \\
R &= \langle A, [A], \{\langle E, F, w \rangle\} \rangle \\
L &= \{\langle e, E \rangle, \langle f, F \rangle, \dots\} \\
G &= \{ \langle A, [B, C, \langle D, [D], \{\langle E, F, w \rangle\} \rangle], \langle 2, 3, w \rangle \rangle, \\
&\quad \langle B, [F, G, E], \emptyset \rangle, \\
&\quad \langle C, [\langle H, [D, E], \{\langle E, F, w \rangle\} \rangle], I, \emptyset \rangle, \\
&\quad \langle D, [J, K], \emptyset \rangle \}
\end{aligned}$$

Note that, aside from the fact that the compaction statements appear ‘inside’ the rules, (8) and (11) only differ in the absence of global order statements; these are merely an abbreviatory device for grammar writers. The derivation of the string *efjekgikj* is given in (12).

(12)

$$\begin{aligned}
&\langle A, [A] \rangle \\
&\Rightarrow \langle A, [B, C, \langle D, [D] \rangle] \rangle \\
&\Rightarrow \langle A, [B, C, \langle D, [D] \rangle] \rangle \\
&\Rightarrow \langle A, [E, F, G, C, \langle D, [D] \rangle] \rangle \\
&\Rightarrow \langle A, [E, F, \langle H, [D, E] \rangle, G, I, \langle D, [D] \rangle] \rangle \\
&\Rightarrow \langle A, [E, F, \langle H, [J, E, K] \rangle, G, I, \langle D, [D] \rangle] \rangle \\
&\Rightarrow \langle A, [E, F, \langle H, [J, E, K] \rangle, G, I, \langle D, [K, J] \rangle] \rangle
\end{aligned}$$

5 A Parsing Algorithm for GIDL

We have developed a GIDL parser based on Earley’s algorithm for context-free parsing (Earley 1970). In Earley’s original algorithm, each edge encodes the interval of the input string it covers. With discontinuous constituents, however, that is no longer an option. In the spirit of Johnson (1985) and Reape (1991), and following Ramsay (1999), we represent edge coverage with bitvectors, stored as integers. For instance, 00101 represents an edge covering words one and three of a five-word sentence.⁶

Our parsing algorithm begins by seeding the chart with passive edges corresponding to each word in the input and then predicting a compacted instance of the start symbol covering the entire input; each final completion of this edge will correspond to a successful parse.

As with Earley’s algorithm, the bulk of the work performed by the algorithm is borne by two steps, *prediction* and *completion*. Unlike the context-free case, however, it is not possible to anchor these steps to string positions, proceeding from left to right. In order for the parser to operate as efficiently as possible, it must be possible for the prediction step to intelligently take word order constraints into account. Once a daughter of an active edge has been found, the other daughters should only be predicted to occur in string positions which are compatible with the word order constraints of the active edge. For example, consider the edge in (13).

$$(13) A \rightarrow B_1 \bullet C_2 ; 1 < 2$$

This notation represents the point in the parse during which the application of this rule has been predicted, and a B has already been located. Assuming that B has been found to cover the third position of a five-word string, two facts are known. From the LP constraint, C cannot precede B , and from the general principle that the RHS of a rule forms a partition of its LHS, C cannot overlap B . Thus C cannot cover positions one, two, or three.

5.1 Compiling LP Constraints into Bitmasks

We can now discuss the integration of GIDL word order constraints into the parsing process. A central insight of our algorithm is that the same data structure used to describe the coverage of an edge can also encode restrictions on the parser’s search space. This is accomplished with two classes of bitvectors: *negative masks* (n-masks) and *positive masks* (p-masks). Efficient bitvector operations (Daniels and Meurers 2002) can then be used to compute, manipulate, and test the encoded constraints.

Negative Masks The n-mask constrains the set of possible coverage vectors that could complete the edge. The 1-positions in a masking vector represent the positions that are masked out: the positions that cannot be filled when completing this

⁶Note that the first word is the rightmost bit.

edge. The 0-positions in the negative mask represent positions that may potentially be part of the edge’s coverage. For the example above, the coverage vector for the edge is 00100 since only the third word *B* has been found so far. Assuming no restrictions from a higher rule in the same domain, the n-mask for *C* is 00111, encoding the fact that the final coverage vector of the edge for *A* must be either 01000, 10000, or 11000 (that is, *C* must occupy position four, position five, or both of these positions). The negative mask in essence encodes information on where the active category cannot be found.

Positive Masks The p-mask encodes information about the positions the active category **must** occupy. This knowledge arises from immediate precedence constraints. For example, consider the edge in (14).

$$(14) D \rightarrow E_1 \bullet F_2 ; 1 \ll 2$$

If *E* occupies position one, then *F* must at least occupy position two; this would be represented by a p-mask of 00010.

Thus in the prediction step, the parser considers each rule in the grammar that provides the symbol being predicted, and for each rule, it generates bitmasks for the new edge, taking both rule-level and domain-level order constraints into account. The resulting masks are checked to ensure that there is enough space in the resulting mask for the minimum number of categories required by the rule.⁷

Then, as part of each completion step, the parser must update the LP constraints of the active edge with the new information provided by the passive edge. As edges are initially constructed from grammar rules, all order constraints are initially expressed in terms of either descriptions or tokens. As the parse proceeds, these constraints are updated in terms of the actual locations where matching constituents have been found. For example, a constraint like $1 < 2$ (where 1 and 2 are tokens) can be updated with the information that the constituent corresponding to token 1 has been found as the first word, i.e. as position 00001.

In summary, compiling LP constraints into bitmasks in this way allows the LP constraints to be integrated directly into the parser at a fundamental level. Instead of weeding out inappropriate parses in a cleanup phase, LP constraints in this parser can immediately block an edge from being added to the chart.

6 Beyond Head-driven Parsing

As described in the GIDL grammar format defined above, the order of the RHS of a grammar rule does not encode the terminal order of the daughters. Instead, it expresses the order in which the parser will search for these elements.

⁷This optimization only applies to epsilon-free grammars. Further work in this regard can involve determining the minimum and maximum yields of each category; some optimizations involving this information can be found in Haji-Abdolhosseini and Penn (2003).

For a simple example of a construction where ordering the non-head daughters is useful, consider a grammar covering raising verbs in Icelandic as discussed in (Sag et al. 1992). Many verbs in Icelandic assign “quirky case” (i.e. non-nominative) to their subjects; these case assignments persist when the subject is raised to be the subject or object of a matrix verb. This is illustrated by the data in (15) – (20).

- (15) Hana virðist vanta peninga
her. seems to-lack money
'She seems to lack money.'
- (16) Barninu virðist hafa batnað veikin
the-child. seems to-have recovered-from the-disease
'The child seems to have recovered from the disease.'
- (17) Verkjanna virðist ekki gæta
the-pains. seem not to-be-noticeable
'The pains don't seem to be noticeable.'
- (18) Hann telur mig vanta peninga
he. believes me. to-lack money
'He believes that I lack money.'
- (19) Hann telur barninu hafa batnað veikin
he believes the-child. to-have recovered-from the-disease
'He believes the child to have recovered from the disease.'
- (20) Hann telur verkjanna ekki gæta
he believes the-pains. not to-be-noticeable
'He believes the pains to be not noticeable.'

In other words, the fact that the subject in (15) and (18) is accusative is a reflection of the embedded verb ‘lack’ rather than the matrix verbs ‘seem’ or ‘believe’; the same situation holds for the dative [(16), (19)] and genitive [(17), (20)] examples. In all other respects, however, the matrix verb is still the head of its clause (it must agree in number with the subject, for example). Thus from a parsing perspective, the embedded verb must be known before it can be determined whether a given noun phrase is an acceptable subject for the matrix verb.

Consider a head-driven parser (van Noord 1997): a variant of a phrase-structure parser in which a designated element (the head) is parsed before any other complement; the non-head daughters that occur to the right of the head are then parsed in the usual left-to-right order. With such a parser, the grammar writer would write a rule like (21) to license the matrix clause.

- (21) $S \rightarrow NP_{\text{subj}} V^{\text{head}} VP_{\text{inf}}$

With such a rule, the parser will first locate the head (here, the *V*), then the *NP*, and finally the *VP*. As a consequence, the constraints in the *VP* on the case of the subject will not be known until after the subject has been found. The parser will therefore try all possible *NPs* as subjects, and then see which the embedded verb phrase rejects.

With the GIDL_P formalism, in contrast, the grammar writer could specify the rule as (22) to avoid this generate-and-test pattern.

$$(22) S \rightarrow V^1, VP_{\text{inf}}^2, NP_{\text{subj}}^3$$

Now the parser will not look for the subject of the clause until the embedded verb phrase has been located, and so only *NPs* with the appropriate case will even be considered.

7 Computational Complexity

Suhre (1999) shows that the membership problem for his LSL grammar formalism (a subset of the GIDL_P formalism; thus comparable results for GIDL_P grammars could be no better) is NP-complete, both when considering the grammar plus the string as input (general membership problem) as well as when only the string is considered as input (fixed membership problem). It has been known since Huynh (1983) that the general membership problem for unordered context-free grammars (ID/LP grammars without LP statements) is also NP-complete, so Suhre's first result is not surprising. That the fixed membership problem for LSL grammars is also NP-complete is less straightforward; fortunately, Suhre (1999, 61ff) demonstrates that it stems from the potential for recursive growth of discontinuities. As a result, when the parser can assume an upper bound on the number of discontinuities in any given constituent, the fixed membership problem becomes polynomial. Formally, this can be achieved by requiring that the number of discontinuities introduced by a recursive non-terminal is bounded by some constant.

Interestingly, a related practical proposal based on linguistic argumentation is discussed by Müller (1999b). He proposes a continuity constraint for linearization-based HPSG which requires saturated phrasal elements (that is, maximal projections) to be continuous.⁸ Müller shows that adding his continuity constraint results in a significant reduction in the number of passive edges and thereby significant improvements in parsing performance. This continuity constraint is weaker than Suhre's condition in that recursion on the level of adjunction is not restricted. It is, however, interesting to note in this context that a grammar incorporating the \bar{X} -schema (Jackendoff 1977) will require all non-head constituents to be maximal projections. In sum, Müller's result strongly suggests that further research on linguistically-motivated continuity constraints can result in efficient parsing of those GIDL_P grammars which include such constraints.

⁸If extraposition is handled via discontinuous constituents, a more complex constraint is required.

8 Evaluation

As discussed at the end of section 4.2, it is possible to take a GIDL P grammar and write out the discontinuity. All non-domain introducing rules must be folded into the domain-introducing rules, and then each permitted permutation of a RHS must become a context-free rule on its own – generally, at the cost of a factorial increase in the number of rules.

This construction indicates the basis for a preliminary assessment of the GIDL P formalism and its parser. The grammar in (23) recognizes a very small fragment of German, focusing on the free word order of arguments and adjuncts in the so-called *Mittelfeld* that occurs to the right of either the finite verb in yes-no questions or the complementizer in complementized sentences.⁹

- (23)
- a) start(s, [])
 - b) $s \rightarrow s(\text{cmp})_1$
 - c) $s \rightarrow s(\text{que})_1$
 - d) $s(\text{cmp}) \rightarrow \text{cmp}_1, \text{clause}_2; \langle [0], s(\text{cmp}), \langle \text{cmp} \langle _ , _ \rangle \langle v(_) \rangle \rangle$
 - e) $s(\text{que}) \rightarrow \text{clause}_1; \langle [0], s(\text{que}), \langle v(_) \langle _ \rangle \rangle$
 - f) $\text{clause} \rightarrow \text{np}(\text{n})_1, \text{vp}_2$
 - g) $\text{vp} \rightarrow v(\text{ditr})_1, \text{np}(\text{a})_2, \text{np}(\text{d})_3$
 - h) $\text{vp} \rightarrow \text{adv}_1, \text{vp}_2$
 - i) $\text{vp} \rightarrow v(\text{cmp})_1, s(\text{cmp})_2$
 - j) $[\text{np}(\text{Case})] \rightarrow \text{det}(\text{Case})_1, \text{n}(\text{Case})_2; 1 \ll 2$
 - k) $v(\text{ditr}) \rightarrow \textit{gab}$ o) $\text{n}(\text{acc}) \rightarrow \textit{Buch}$ s) $\text{det}(\text{acc}) \rightarrow \textit{das}$
 - l) $\text{comp} \rightarrow \textit{dass}$ p) $\text{adv} \rightarrow \textit{dort}$ t) $\text{n}(\text{dat}) \rightarrow \textit{Frau}$
 - m) $\text{det}(\text{dat}) \rightarrow \textit{der}$ q) $v(\text{cmp}) \rightarrow \textit{denkt}$ u) $\text{adv} \rightarrow \textit{gestern}$
 - n) $\text{n}(\text{nom}) \rightarrow \textit{Mann}$ r) $\text{det}(\text{nom}) \rightarrow \textit{der}$

The basic idea of this grammar is that domain compaction only occurs at the top of the head path, after all complements and adjuncts have been found. When the grammar is converted into a CFG, the effect of the larger domain can only be mimicked by eliminating the clause and vp constituents altogether.

As a result, while this GIDL P grammar has 10 syntactic rules, the corresponding flattened CFG has 201 rules (with the number of adverbs artificially limited to two). In an experiment, the four sample sentences in (24)¹⁰ were parsed with both our prototype GIDL P parser (using the GIDL P grammar) as well as a vanilla Earley CFG parser (using the CFG); the results are shown in (25).

⁹The symbol $_$ is used to denote the set of all categories.

¹⁰The grammar and example sentences are intended as a formal illustration, not a linguistic theory; because of this, we have not provided glosses.

- (24) a) *Gab der Mann der Frau das Buch?*
 b) *dass das Buch der Mann der Frau gab.*
 c) *dass das Buch gestern der Mann dort der Frau gab.*
 d) *Denkt der Mann dass das Buch gestern der Mann dort der Frau gab?*

(25)

Sentence	Active Edges		Passive Edges	
	GIDL	CFG	GIDL	CFG
a)	18	327	16	15
b)	27	338	18	16
c)	46	345	27	27
d)	75	456	36	24

Averaging over the four sentences, the GIDL grammar requires 89% fewer active edges.¹¹ It is important to keep in mind that the GIDL grammar is more general than the CFG: in order to obtain a finite number of CFG rules, we had to limit the number of adverbs. When using a grammar capable of handling longer sentences with more adverbs, the number of CFG rules (and active edges, as a consequence) increases factorially.

Timings have not been included in (25); it is generally the case that the GIDL parser/grammar combination was slower than the CFG/Earley parser. This is an artifact of the use of atomic categories, however. For the large feature structures used as categories in HPSG, we expect the larger numbers of edges encountered while parsing with the CFG to have a greater impact on parsing time, to the point where the GIDL grammar/parser is faster.

9 Summary

In this paper, we have introduced a grammar format that can be used as a processing backbone for linearization-based HPSG grammars that supports the specification of discontinuous constituents and word order constraints on domains that extend beyond the local tree. We have presented a prototype parser for this format illustrating the use of order constraint compilation techniques to improve efficiency. Future work will concentrate on additional techniques for optimized parsing as well as the application of the parser to feature-based grammars. We hope that the GIDL grammar format will encourage research on such optimizations in general, in support of efficient processing of relatively free constituent order languages using linearization-based HPSG.

¹¹It also generates additional passive edges corresponding to the extra non-terminals *vp* and *clause*.

References

- Bonami, Olivier, Godard, Danièle and Marandin, Jean-Marie. 1999. Constituency and word order in French subject inversion. In Gosse Bouma, Erhard W. Hinrichs, Geert-Jan M. Kruijff and Richard T. Oehrle (eds.), *Constraints and Resources in Natural Language Syntax and Semantics*, Studies in Constraint-Based Lexicalism, pages 21–40, Stanford, CA: CSLI.
- Daniels, Michael W. and Meurers, W. Detmar. 2002. Improving the efficiency of parsing with discontinuous constituents. In Shuly Wintner (ed.), *Proceedings of NLULP-02: The Seventh International Workshop on Natural Language Understanding and Logic Programming*, pages 49–68, Roskilde University, Computer Science Department, Copenhagen, Denmark.
- Daniels, Michael W. and Meurers, W. Detmar. 2004. A grammar formalism and parser for linearization-based HPSG. In *Proceedings of the 20th International Conference on Computational Linguistics (COLING 2004)*, pages 169–175, Geneva, Switzerland.
- Donohue, Cathryn and Sag, Ivan A. 1999. Domains in Warlpiri. In *Abstracts of the Sixth Int. Conference on HPSG*, pages 101–106, Edinburgh: University of Edinburgh.
- Earley, Jay. 1970. An Efficient Context-Free Parsing Algorithm. *Communications of the ACM* 13(2), 94–102, also in Grosz et al. (1986).
- Gazdar, Gerald, Klein, Ewan, Pullum, Geoffrey K. and Sag, Ivan A. 1985. *Generalized Phrase Structure Grammar*. Cambridge, MA: Harvard UP.
- Götz, Thilo and Meurers, Walt Detmar. 1997. The ConTroll System as Large Grammar Development Platform. In *Proceedings of the Workshop “Computational Environments for Grammar Development and Linguistic Engineering (ENVGRAM)” held at ACL/EACL*, pages 38–45, Association for Computational Linguistics, Madrid: Universidad Nacional de Educación a Distancia.
- Götz, Thilo and Penn, Gerald. 1997. A Proposed Linear Specification Language. Volume 134 in *Arbeitspapiere des SFB 340*, Universität Tübingen.
- Grosz, Barbara, Jones, Karen Sparck and Webber, Bonnie Lynn (eds.). 1986. *Readings in Natural Language Processing*. Los Altos, CA: Morgan Kaufmann.
- Haji-Abdolhosseini, Mohammad and Penn, Gerald. 2003. ALE Reference Manual. Manuscript, University of Toronto. http://www.ale.cs.toronto.edu/docs/ref/ale_ref.pdf.
- Huynh, Dung T. 1983. Commutative Grammars: The Complexity of Uniform Word Problems. *Information and Control* 57(1), 21–39.

- Jackendoff, Ray. 1977. *X-Bar Syntax: A Study of Phrase Structure*. Cambridge, Mass.: MIT Press.
- Johnson, Mark. 1985. Parsing with discontinuous constituents. In *Proceedings of the 23rd Annual Meeting of the Association for Computational Linguistics*, pages 127–132, Chicago.
- Kasper, Robert, Kathol, Andreas and Pollard, Carl. 1995. A relational interpretation of linear precedence constraints, the Ohio State University.
- Kathol, Andreas. 1995. *Linearization-Based German Syntax*. Ph.D.thesis, The Ohio State University.
- Kathol, Andreas and Pollard, Carl. 1995. Extraposition via Complex Domain Formation. In *Proceedings of ACL*, pages 174–180.
- Kay, Martin. 1990. Head-Driven Parsing. In Masaru Tomita (ed.), *Current Issues in Parsing Technology*, Dordrecht: Kluwer, previously published in the proceedings of the International Workshop on Parsing Technologies, 1989.
- Lewis, Harry R. and Papadimitriou, Christos H. 1998. *Elements of the Theory of Computation*. Upper Saddle River, NJ: Prentice-Hall, second edition.
- Müller, Stefan. 1999a. *Deutsche Syntax deklarativ. Head-Driven Phrase Structure Grammar für das Deutsche*. Linguistische Arbeiten, No. 394, Tübingen: Niemeyer.
- Müller, Stefan. 1999b. Restricting Discontinuity. Verbmobil Report 237, DFKI, Saarbrücken, also published in the Proceedings of GLDV 99 (Frankfurt/Main).
- Müller, Stefan. 2004. Continuous or discontinuous constituents? A comparison between syntactic analyses for constituent order and their processing systems. *Research on Language and Computation, Special Issue on Linguistic Theory and Grammar Implementation 2(2)*, 209–257.
- Penn, Gerald. 1999. Linearization and WH-extraction in HPSG: Evidence from Serbo-Croatian. In Robert D. Borsley and Adam Przepiórkowski (eds.), *Slavic in HPSG*, pages 149–182, Stanford, CA: CSLI.
- Ramsay, Allan M. 1999. Direct parsing with discontinuous phrases. *Natural Language Engineering 5(3)*, 271–300.
- Reape, Mike. 1991. Parsing bounded discontinuous constituents: Generalisations of some common algorithms. In Mike Reape (ed.), *Word Order in Germanic and Parsing*, pages 41–70, DYANA R1.1.C, ESPRIT BR 3175.
- Reape, Mike. 1993. *A Formal Theory of Word Order: A Case Study in West Germanic*. PhD thesis., Univ. of Edinburgh.

- Richter, Frank and Sailer, Manfred. 2001. On the left periphery of German finite sentences. In Detmar Meurers and Tibor Kiss (eds.), *Constraint-Based Approaches to Germanic Syntax*, Studies in Constraint-Based Lexicalism, pages 257–300, Stanford, CA: CSLI.
- Sag, Ivan, Karttunen, Lauri and Goldberg, Jeffrey. 1992. A Lexical Analysis of Icelandic Case. In Ivan Sag and Anna Szabolcsi (eds.), *Lexical Matters*, pages 302–318, Stanford, CA: CSLI.
- Shieber, Stuart M. 1984. Direct Parsing of ID/LP Grammars. *Linguistics and Philosophy* 7, 135–154.
- Suhre, Oliver. 1999. *Computational Aspects of a Grammar Formalism for Languages with Freer Word Order*. Diplomarbeit, Department of Computer Science, University of Tübingen, published 2000 as Volume 154 in Arbeitspapiere des SFB 340.
- van Noord, Gertjan. 1991. Head corner parsing for discontinuous constituency. In *Proceedings of the 29th Annual Meeting of the Association for Computational Linguistics*, pages 114–121.
- van Noord, Gertjan. 1997. An Efficient Implementation of the Head-Corner Parser. *Computational Linguistics* 23(3).
- Yatabe, Shuichi. 1996. Long-distance scrambling via Partial Compaction. In Masatoshi Koizumi, Masayuki Oishi and Uli Sauerland (eds.), *Formal Approaches to Japanese Linguistics* 2, pages 303–317, Cambridge, MA: MITWPL.

A typology of negation in a constraint-based framework of syntax and semantics

Henriette de Swart

Universiteit Utrecht

Proceedings of the 11th International Conference on
Head-Driven Phrase Structure Grammar

Center for Computational Linguistics, Katholieke Universiteit Leuven

Stefan Müller (Editor)

2004

Stanford, CA: CSLI Publications

pages 112–118

de Swart, Henriette. 2004. A typology of negation in a constraint-based framework of syntax and semantics. In Stefan Müller (ed.), *Proceedings of the 11th International Conference on Head-Driven Phrase Structure Grammar*, Center for Computational Linguistics, Katholieke Universiteit Leuven, 112–118. Stanford, CA: CSLI Publications. DOI: 10.21248/hpsg.2004.6.



0. Abstract

Negation and negative indefinites raise problems for the principle of compositionality of meaning, because we find both double and single negation readings in natural languages. De Swart and Sag (2002) solve the compositionality problem in a polyadic quantifier framework. All negative quantifiers are collected into an N-store, and are interpreted by means of iteration (double negation) or resumption (negative concord) upon retrieval. This paper extends the earlier analysis with a typology of negation and negative indefinites using bi-directional optimality theory (OT). The constraints defined are universal, but their ranking varies from one language to the next. In negative concord languages, the functional motivation for the marking of ‘negative variables’ wins out. Double negation languages value first-order iteration. The bi-directional set-up is essential, for syntactic and semantic variation go hand in hand.¹

1. Introduction

Languages generally have ways to express negation, i.e. something that corresponds to the first-order logic connective \neg . In English this would be *not*. Many languages also have pronominal expressions negating the existence of individuals having a certain property, i.e. something that corresponds to $\neg\exists x$. In English, this would be *nobody*, *nothing*. If we assume that knowledge of first-order logic is part of human cognition, we would seem to predict that negation and negative quantifiers behave alike across languages. From empirical research by typologists and theoretical linguists, we know that this is not the case. In particular, differences arise in the way languages express $\neg\exists x \exists y \exists z$. The variables y and z here indicate ‘negative variables’ in the sense of Corblin and Tovena (2003: 326). They correspond to arguments that must be interpreted within the scope of negation. The simplest way to realize such arguments would be to use (plain) indefinite pronouns. We find this case in Dutch:

- (1) a. *Niemand* heeft *iets* gezien. [Dutch]
Nobody has something seen. ‘Nobody saw anything’

But many languages treat (plain) indefinite pronouns like positive polarity items, and use a special class of negative polarity items within the scope of negation. English is a case at hand. (2a) is not ungrammatical, but it does not express the meaning $\neg\exists x \exists y$:

- (2) a. *#Nobody* saw *something*. [English]
b. Nobody saw *anything*.

Languages like Romance, Slavic, Greek, etc. use so-called ‘n-words’, rather than negative polarity items (cf. Haspelmath 1997 for an overview):

- (3) a. A: *Qué viste?* B: *Nada* [Spanish]
A: What did you see? B: Nothing
b. *Nessuno mangia.* [Italian]
Nobody ate.
c. *No vino nadie.* [Spanish]
Not came nobody. = Nobody came
d. *Nadie miraba a nadie*
Nobody looked at nobody. = Nobody looked at anybody

¹ Many thanks for helpful comments and feedback from audiences at Utrecht University, Radboud University, the University of Amsterdam, Georgetown University, the University of California at Santa Cruz, Hopkins University, and the University of Leuven. All remaining errors are of course my own. The financial support of the Netherlands Organization for Scientific Research (grant 051-02-070 for the cognition project ‘Conflicts in Interpretation’) is hereby gratefully acknowledged.

Negative polarity items do not contribute a semantic negation, and require a licenser, whereas n-words can provide a semantic negation in elliptical answers (3a), and in sentences in which no other expression contributes a semantic negation (3b) (cf. Ladusaw 1992, Vallduví 1994). This paper is concerned with n-words, not with negative polarity items.

2. An HPSG analysis of double negation and negative concord.

The main semantic claims made by de Swart and Sag (2002) are that n-words are inherently negative, and that both double negation and negative concord involve polyadic quantification. Double negation involves iteration (function application), and is first-order definable. Negative concord is interpreted in terms of resumption:

- Resumption of a k-ary quantifier (Keenan and Westerståhl 1997).
 $Q'_E{}^{A1, A2, \dots, Ak} (R) = Q_{Ek}{}^{A1x A2x \dots Ak} (R)$.

A sequence of k quantifiers Q' binding just one variable each and taking a k -ary relation R as its scope is interpreted as one quantifier Q binding k variables predicating over R . E.g. a sequence of quantifiers *No* x , *No* y , *No* z predicating over a three-place relation $R(x,y,z)$ is interpreted as $No_{x,y,z} R(x,y,z)$, claiming that no triple $\langle x,y,z \rangle$ satisfies the relation R . At the first-order level, the resumptive quantifier is equivalent to $\neg \exists x \exists y \exists z R(x,y,z)$, so we obtain the NC reading, as desired.

The syntax-semantics interface defines how we obtain the DN and NC readings from the syntax. HPSG uses a notion of Cooper storage in which all quantifiers are collected into a store, and interpreted upon retrieval from the store (cf. Manning, Iida and Sag 1999). This mechanism is generally used to account for scope ambiguities, but de Swart and Sag (2002) extend it to account for polyadic quantification. All negative (anti-additive) quantifiers are collected into an N-store. Interpretation upon retrieval from the store is by means of iteration (leading to DN) or by resumption (leading to NC). The formal definition of retrieve is as follows:

- Retrieve: Given a set of generalized quantifiers Σ and a partition of Σ into two sets Σ_1 and Σ_2 , where Σ_2 is either empty or else $\Sigma_2 = \{NO_{\sigma_1}{}^{R1}, \dots, NO_{\sigma_2}{}^{R2}\}$,
 $Retrieve(\Sigma) =_{\text{def}} \text{iteration}(\Sigma_1 \cup \text{res}(\Sigma_2))$.

So the grammar does not decide between DN and NC. This is what we need for a language like French, in which both readings are available. Consider the ambiguity of the following sentence in the HPSG analysis of de Swart and Sag (2002):

- (4) *Personne n'aime personne.* [French]
- (a) Arg-St<[Store { $NO_{\{x\}}^{\{Person(x)\}}$ }}, [Store { $NO_{\{y\}}^{\{Person(y)\}}$ }}]>
 Content Quants < $NO_{\{x\}}^{\{Person(x)\}}$, $NO_{\{y\}}^{\{Person(y)\}}$ >
 Nucleus *Love(x,y)*
 Semantic interpretation: $NO(\text{HUM}, \{x | NO(\text{HUM}, \{y | x \text{ loves } y\})\})$
 In first-order logic: $\neg \exists x \neg \exists x \text{ Love}(x,y)$ [DN]
- (b) Arg-St<[Store { $NO_{\{x\}}^{\{Person(x)\}}$ }}, [Store { $NO_{\{y\}}^{\{Person(y)\}}$ }}]>
 Content Quants < $NO_{\{x,y\}}^{\{Person(x), Person(y)\}}$ >
 Nucleus *Love(x,y)*
 Semantic interpretation: $NO_{E2}^{\text{HUM} \times \text{HUM}}(\text{LOVE})$
 In first-order logic: $\neg \exists x \exists y \text{ Love}(x,y)$ [NC]

(4a) and (4b) are identical as far as the argument structure, the storing mechanism, and the interpretation of the *love* relation is concerned. The difference resides in the interpretation of the polyadic quantifier: iteration in (4a), resumption in (4b). The main insights of this analysis

are the following. The HPSG grammar assumes no lexical difference between negative quantifiers and n-words, so in the rest of this paper we use the term ‘neg expression’ to generalize over both. The analysis works for n-words in argument and adjunct position alike (so *nobody*, *nothing*, as well as *never*, *nowhere*). Finally, it does not involve empty elements or ‘hidden’ negations in the syntactic structure. These are major advantages of this proposal.

The OT analysis comes in when we try to relate the HPSG analysis to languages that do not allow double negation and negative concord as freely as French does. In general, the combination of two negative quantifiers in English leads to a double negation reading, and resumption is only marginally available as an interpretive strategy. On the other hand, Spanish, Greek, Polish, and many other languages are typically negative concord languages, which hardly ever realize the iteration version of the polyadic quantifier analysis. The analysis proposed by de Swart and Sag (2002) does not predict cross-linguistic variation where it arises (Spanish vs. English, for example). The aim of this paper is extend the earlier analysis with a bi-directional OT component in order to define a typology of negation.

3. A typology of negation within Optimality Theory

We need to study negation from two perspectives: the generation perspective (how does a speaker express a negative meaning in a particular language?) and the interpretation perspective (how does the hearer interpret a sentence with a sequence of negative expressions in a particular language?). In order to allow for variation in the answers to these questions, we use the framework of Optimality Theory (OT). OT uses universal, but violable constraints, and allows variation in the ranking of the constraints from one language to the next. In an OT syntax, the input is a meaning (a first-order formula), the set of candidates generated by GEN is a set of possible forms, and a ranked set of violable constraints selects the optimal form for the given meaning. In OT semantics, the input is a form (a well-formed sentence), the set of candidates is a set of possible meanings (first-order formulae), and a ranked set of violable constraints selects the optimal interpretation for the given form. Bi-directional OT looks at balanced (‘harmonic’) pairs of form and meaning.

The starting point of the analysis is the observation that negative sentences are formally and interpretationally marked with respect to affirmative sentences. This means that we expect to see the negative meaning reflected in the syntax, and the negative syntax to be reflected in the meaning. The constraint FaithNeg (Faith negation) accounts for this intuition:

- ◆ **FaithNeg**
Reflect the non-affirmative nature of the input in the output.

FaithNeg is a faithfulness constraint, i.e. a constraint that aims at a faithful reflection of input features in the output. Since negation is marked in all languages, we take FaithNeg to be universally ranked at the top. In OT, faithfulness constraints are balanced by markedness constraints, which are output oriented. The markedness constraint that plays a role in negative statements is *Neg:

- ◆ ***Neg**
Avoid negation in the output

*Neg is obviously in conflict with FaithNeg. Such conflicting constraints are characteristic of OT style analyses. FaithNeg and *Neg play a role in OT syntax as well as in OT semantics. In addition, we need two maximizing constraints, one aimed at the syntax (MaxNeg), the other one aimed at the semantics (IntNeg):

- ◆ **MaxNeg**
Mark ‘negative variables’ (i.e. the arguments that are interpreted within the scope of negation)

- ◆ IntNeg
Force Iteration (i.e. every neg expression in the form contributes a semantic negation at the first-order level in the output)

The functional motivation for the marking of negative variables (Haspelmath 1997, Corblin and Tovena 2003) explains why the use of n-words is widespread among natural languages. However, the use of n-words is not universal: languages like Dutch, English, Turkish, etc. do not use n-words. This suggests that MaxNeg is not a hard constraint, and its position in the constraint ranking is not the same for every language. We can account for the difference between languages with and without n-words by changing the position of MaxNeg relative to *Neg. If *Neg is ranked higher than MaxNeg, the optimal way to express the meaning $\neg\exists x_1\exists x_2\dots\exists x_n$ is by means of indefinite pronouns. If MaxNeg is ranked higher than *Neg, n-words are used to express indefinites under negation. The following OT syntactic tableaux reflect this for the binding of two variables:

Tableau 1 (generation of indefinite, for Dutch, Turkish, etc.)

Meaning	Form	FaithNeg	*Neg	MaxNeg
$\neg\exists x_1\exists x_2$	Indef+indef	*		
☞	neg+indef		*	*
	neg + neg		**	

Tableau 2: (generation of n-word for Greek, Romance, Slavic, etc.)

Meaning	Form	FaithNeg	MaxNeg	*Neg
$\neg\exists x_1\exists x_2$	indef+indef	*		
☞	neg+indef		*	*
	neg + neg			**

The top ranking of FaithNeg makes it impossible to express indefinites under negation by indefinites exclusively (in the absence of a marker of sentential negation). In tableaux 1 and 2, the candidates that we need to compare are those that mark negation somehow in the output. This invariably leads to a violation of *Neg. Two neg expressions are ‘worse’ than one, so the combination of two neg expressions incurs two violations of *Neg.

As far as generation is concerned, we conclude that languages that allow indefinites under negation (Dutch, Turkish, etc.), and languages that use n-words (Romance, Slavic, Greek, etc.) differ in their ranking of the two constraints MaxNeg and *Neg. This approach immediately raises the question of the interpretation of the expressions involved. In isolation, we cannot determine whether a particular expression is a negative quantifier or an n-word, because they both contribute the meaning $\neg\exists$ (cf. 3a, b). Following de Swart and Sag (2002), I assume that this question is decided in the grammar, not in the lexicon. The use of neg expressions in a generative OT system means that we run into the recoverability problem: from the expressions generated, we can derive multiple interpretations, not only the intended one. Recoverability is assured by the way the generation of negative sentences hangs together with their interpretation. So we need an OT semantic component.

In the interpretive system, FaithNeg outranks all the other constraints as usual. MaxNeg is a purely syntactic constraint that does not play a role in interpretation. So the constraints that need to be ordered are *Neg and IntNeg. If *Neg is ranked higher than IntNeg in the OT semantics, a sequence of multiple Neg expressions leads to a single negation meaning by resumption. If IntNeg is ranked higher than *Neg, a series of Neg expressions is interpreted as multiple negation by forcing iteration. The following tableaux illustrate the two possible rankings and their optimal output:

Tableau 3: double negation (interpretation of Dutch, English, etc.)

Form	Meaning	FaithNeg	IntNeg	*Neg
neg + neg	$\exists x_1 \exists x_2$	*	**	
	$\neg \exists x_1 \exists x_2$		*	*
\wp	$\neg \exists x_1 \neg \exists x_2$			**

Tableau 4: negative concord (interpretation of Romance, Slavic, Greek, etc.)

Form	Meaning	FaithNeg	*Neg	IntNeg
neg + neg	$\exists x_1 \exists x_2$	*		
\wp	$\neg \exists x_1 \exists x_2$		*	*
	$\neg \exists x_1 \neg \exists x_2$		**	

The top ranking of FaithNeg implies that we cannot interpret a statement involving two neg expressions without a reflection of the non-affirmative meaning. As a result, the relevant candidates we compare have at least one negation in the output, and always incur a violation of *Neg. The combination of two neg expressions leads to a double negation reading in languages like Dutch and English, for the constraint IntNeg is ranked higher than *Neg in tableau 3. Because *Neg outranks IntNeg in tableau 4, single negation readings win over double negation readings in NC languages such as Spanish, Italian, Greek, Polish, etc.

Collapsing the generation and interpretation perspective, we derive the following two rankings for negative concord and double negation languages:

Bidirectional grammar

- Negative concord languages: FaithNeg >> MaxNeg >> *Neg >> IntNeg
- Double negation languages: FaithNeg >> IntNeg >> *Neg >> MaxNeg

In the full paper, I argue that only rankings where MaxNeg and IntNeg are distributed on either side of *Neg reflect viable options for a linguistic system that balances generation and interpretation of negative statements. In sum:

- **Negative Concord:** if you mark ‘negative variables’ (MaxNeg >> *Neg in syntax), then make sure you do not force Iteration (*Neg >> IntNeg in semantics).
- **Double Negation:** if you force Iteration, (IntNeg >> *Neg in semantics), then make sure you do not mark ‘negative variables’ (*Neg >> MaxNeg in syntax).

4. Concluding remarks.

A bi-directional version of Optimality Theory offers new perspectives on the range of variation we find in natural language for the expression and interpretation of negation. Patterns that are frequently found in natural language, but do not display absolute tendencies can be fruitfully described in a framework that formulates universal constraints, but allows these constraints to be violable. Bi-directionality is a central feature of our analysis, because it relates the semantic compositionality problems raised by negative concord to the functional tendencies to formally mark the scope and focus of negation, in accordance with the view on compositionality advanced by Blutner, Hendriks and de Hoop (2003).

Many further questions arise in the domain of negative concord languages. As we know from French, double negation readings do arise in negative concord languages, and this requires the possibility of overlap between interpretive constraints. Furthermore, NC languages vary in their interaction between n-words and the marker of sentential negation. Slavic languages, Greek, Afrikaans, etc. always require the presence of a marker of sentential negation in negative sentences. Languages such as Spanish, Italian, Portuguese display an asymmetry between pre-verbal and postverbal n-words. The different subclasses can be

accounted for with the help of two extra constraints (NegFirst and MaxSN), which are discussed in the full paper. These constraints only play a role in the OT syntax, they do not affect the interpretive system. This paper thus supports the conclusions from de Swart and Sag (2002), who argue that the grammar is responsible for the differences between negative concord and double negation languages by means of the interpretation mechanisms for polyadic quantification. The position and distribution of the marker of sentential negation in negative concord is relevant for syntax, but does not affect the semantics.

Selected References

- Blutner, R. (2000). Some aspects of optimality in natural language interpretation, *Journal of Semantics* 17: 189-216.
- Blutner, R., P. Hendriks and H. de Hoop (2003). A new hypothesis on compositionality, *Proceedings of ICCS 2003*, Sidney.
- Boersma P. (1998). *Functional phonology*, PhD diss. University of Amsterdam.
- Corblin, F. and L. Tovenà (2003). L'expression de la négation dans les langues romanes, in: D. Godard (ed). *Les langues romanes: problème de la phrase simple*, Paris: CNRS Editions, 279-342.
- Corblin, F., V. Déprez, H. de Swart and L. Tovenà (2004). Negative concord, in: F. Corblin and H. de Swart (eds.). *Handbook of French Semantics*, Stanford: CSLI Publications.
- Haspelmath, M. (1997). *Indefinite pronouns*, Oxford: Clarendon Press.
- Herburger, E. (2001). The negative concord puzzle revisited, *Natural Language Semantics* 9, 289-333.
- Horn, L. (1989). *A natural history of negation*, Chicago: University of Chicago Press.
- Jespersen, O. (1917). *Negation in English and other languages*, Copenhagen: A.F. Høst. Reprinted in: *Selected writings of Otto Jespersen* (1962), London: George Allen and Unwin, 3-151.
- Keenan, E. and D. Westerståhl (1997). Generalized quantifiers in linguistics and logic, in: J. van Benthem and A. ter Meulen (eds.). *Handbook of Logic & Language*, Amsterdam: Elsevier, 837-893.
- Ladusaw, W. (1992). Expressing negation, *Proceedings of SALT 2*, Columbus: Ohio State University, 237-259.
- Manning, C., I. Sag and M. Iida (1999). The lexical integrity of Japanese causatives, *Nordic Journal of Linguistics* 21, 107-144.
- Swart, H. de and I. Sag (2002). Negation and negative concord in Romance, *Linguistics and Philosophy* 25: 373-417.
- Vallduví, E. (1994). Polarity items, n-words and minimizers in Catalan and Spanish, *Probus* 6: 263-294.
- Zanuttini, R. (1991). *Syntactic properties of sentential negation*, PhD. Diss. University of Pennsylvania.
- Zeevat, H. (2000). The asymmetry of optimality theoretic syntax and semantics, *Journal of Semantics* 17: 243-262.

Mismatches at the syntax-semantics interface

Markus Egg 

Universität Saarbrücken

Proceedings of the 11th International Conference on
Head-Driven Phrase Structure Grammar

Center for Computational Linguistics, Katholieke Universiteit Leuven

Stefan Müller (Editor)

2004

Stanford, CA: CSLI Publications

pages 119–139

Egg, Markus. 2004. Mismatches at the syntax-semantics interface. In Stefan Müller (ed.), *Proceedings of the 11th International Conference on Head-Driven Phrase Structure Grammar*, Center for Computational Linguistics, Katholieke Universiteit Leuven, 119–139. Stanford, CA: CSLI Publications. DOI: 10.21248/hpsg.2004.7.



Abstract

Recent analyses of mismatches at the syntax-semantics interface investigate e.g. modification of agentive nouns (Larson, 1998), modification of quantifying pronouns (Abney, 1987), or recursive modification (Kasper, to appear). Each of these analyses is tailored to a specific set of data, and it is not immediately obvious how they could be generalised to cover a larger set of data.

I propose a unified analysis for these mismatches that attempts to bring out their common ground. This analysis shares some of its basic intuitions with the one of Kasper, but is more general because the mismatches are handled locally in the `CONT` feature. Its pivot is an elaborate syntax-semantics interface that is based on a surface-oriented syntactic analysis. This analysis generalises easily to the mismatches at the morphology-semantics interface for German separable-prefix verbs that were discussed in Müller (2003).

1 Introduction

Semantic scope of constituents often depends on their syntactic constellation.¹ In this respect, the syntax-semantics interface (SSI) is *iconic*: Configurational asymmetries of syntactic tree structures are mapped onto semantic asymmetries. The crucial notion here is (unilateral) *c-command*: If a constituent C_1 *c-commands* a constituent C_2 (but not vice versa), C_1 has wide scope over C_2 .²

Evidence for this iconicity can be found e.g. in cases of multiple modification by scope-bearing modifiers. Here the syntactic order of the modifiers determines their scope. Consequently, switching the order of modifiers around in such cases of multiple modification has an impact on their meaning. Consider e.g. (1a) and (1b), which differ in the order of the modifiers:

- (1) (a) a former apparent politician
(b) an apparent former politician

Their meanings are different, ‘a person who used to resemble a politician’ for (1a) and ‘a person who resembles someone who used to be a politician’ for (1b), respectively. This semantic difference is due to the fact that the preceding modifier M_1 *c-commands* the following modifier M_2 , but not vice versa. Following Kiss (1995) I assume that the *Mittelfeld* of German sentences is binary-branching, too. The relevant part of the syntactic structure in (1a) und (1b) can then be rendered schematically by (2):

¹Scope relations of nominal quantifiers among themselves are a well-known exception here.

²*C-command* relates nodes in a syntax tree. A node A *c-commands* a node B iff (a) A and B are dominated by the same branching nodes in the tree, (b) A does not dominate B or vice versa, and (c) $A \neq B$.

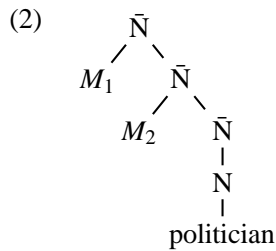

However, in many modification structures there is no such iconicity, because the syntactic asymmetry does not directly map onto a semantic one. In these cases, the modifier has scope (optionally or obligatorily) only over a *part* of the expression it modifies.

As a first example, consider (3). Its preferred reading can be approximately rendered as ‘person who usually dances beautifully’.³

(3) beautiful dancer

The preferred reading can be derived in two steps. First, we break down the semantics of agentive nouns like *dancer* in the stem and the affix meaning, where the stem semantics emerges as an argument of the functor which is the semantic contribution of the affix:

(4) $\underbrace{\text{‘person who usually’}}_{\text{affix meaning}} \dots \underbrace{\text{‘dances’}}_{\text{stem meaning}}$

Second, we then let the adjective pertain to the *verb stem* only, which means that it ends up in the scope of the affix *-er*. This follows directly from applying the affix meaning ‘person who usually *X-es*’ (where *X* is the meaning of the scope domain of the affix) to the meaning of the stem only *after* modification by the adjective.

In addition, (3) also has a reading ‘beautiful person who usually dances’. Here the adjective pertains semantically to the modified noun as a whole, hence, semantic construction for this reading is trivial.

Examples like (5), where an ‘indefinite’ pronoun like *everyone* or *something* is modified, are equally anti-iconic, because their modifiers pertain semantically only to the *restriction* of the quantification as introduced in the pronoun semantics (e.g., for *everyone*, the property of being a person). I.e., while the semantics of *everyone* is ‘set of properties such that every person has them’, the meaning of (5a) is ‘set of properties such that every person *in this room* has them’. In a similar fashion, the meaning of (5b) emerges: The meaning of the modified pronoun is ‘set of properties such that at least one thing has them’, hence, by pertaining the semantic contribution of the modifier to the restriction of the quantification we obtain the meaning of (5b) as ‘set of properties such that at least one blue thing has them’.

³I do not attempt to reconstruct the semantics of these agentive nominals fully, since for the line of argumentation in the present paper the exact spellout of the affix semantics is not relevant. All that matters is that it comprises an operator that has the verb stem semantics in its scope.

- (5) (a) everyone in this room
(b) something blue

(3) differs from (5) in that the latter have only the anti-iconic reading while (3) is ambiguous between the sketched anti-iconic reading and the iconic reading ‘beautiful person characterised by dancing’. This is due to the fact that an application of the modifier semantics to the semantic contribution of the modified expression as a whole is feasible for (3), but not for (5).

Some conclude from such syntax-semantics mismatches that semantic structure reflects (and is iconic to) a not directly visible layer of syntactic structure like *Logical Form*. This layer may differ considerably from syntactic surface structure, but in this way the iconicity of syntax and semantics could be upheld. In particular, generative grammarians propose such analyses of this kind for data like (3) and (5) (Larson 1998 and Abney 1987, respectively).⁴ However, the analysis proposed in this paper assumes only a surface-oriented syntactic structure.

Kasper (to appear) has pointed out that the modification of modifiers is yet another puzzle for semantic construction. The challenge is to derive their semantic representation in a way that models the fact that the scope of the modifier of a modifier *M* may only extend over *M* but not over the expression modified by *M*. E.g., the intensionalisation expressed in *potentially* in (6) relates only to the adjective but not to the noun modified by the full AP. Thus, (6b) refers to abstract items whose being a plan is undisputed, but whose controversiality is not:

- (6) (a) potentially controversial
(b) potentially controversial plan

While this puzzle seems to be unrelated to the phenomena discussed so far, I will show that in Kasper’s analysis modification of modifiers emerges as yet another instance of the syntax-semantics anti-iconicity exhibited by (3) and (5).

The structure of the paper is the following. After giving a more formal account of the data in section 2, I will discuss competing approaches, in particular, Kasper’s analysis, in section 3. After a brief introduction to the formalism on which my analysis is based and its implementation as the semantic component of an HPSG grammar (Pollard and Sag, 1994) in section 4, I will present my own analysis (section 5). In the outlook section 6 I will point out that this analysis is easily extendable to other problematic issues of relating the semantics of a larger constituent to the semantic contributions of its parts, with a focus on the ‘bracketing paradox’ as noted by Lüdelling (2001) and analysed by Müller (2003) for German nominalisations like *Losgerenne*, which refers to a repeated beginning of a running.

⁴See also Sag (1997) and Kathol (1999) for further discussion of Abney’s analysis of (5).

2 Formalisation of the data

The goal of this section is to make the argument of the paper more transparent by reformulating the data in terms of expressions of the λ -calculus. Their reformulation will follow the order in which they were presented in the preceding section.

2.1 Agentive nouns

First comes the modification of agentive nouns. If we ignore issues of argument binding for the purposes of this paper, the semantics of the agentive affix *-er* can be defined as in (7a) as a function from the verb semantics P to the set of individuals that are identical to an individual x such that when x participates in an eventuality⁵ e (this is expressed by the relation **in**), then e is usually a P -eventuality where x is the agent. Here ‘ \vec{y} ’ is shorthand for a sequence of zero or more individual arguments of the verb.

The definition (7b) of the generic quantifier GEN is (one version of) the quantifier as discussed in Krifka et al. (1995):

- (7) (a) $\lambda P \lambda z. \text{GEN}[e, x](x \text{ in } e \wedge z = x, \exists \vec{y}. P(x, \vec{y})(e))$
 (b) $\text{GEN}[e, x](R(x)(e), C(x)(e))$ iff $R(x)(e)$ usually entails $C(x)(e)$

The meaning of *dancer* is then (8a), the set of people such that when they are participating in an eventuality, it is usually an eventuality of them dancing. Here the semantic contribution of the verb stem is underlined. If we now pertain the semantics of the adjective to only this underlined part, we obtain the representation (8b) for the preferred reading of (3). Here the adjective semantics is in the scope of GEN, thus, the expression refers to people who are usually dancing beautifully. Its other reading is represented by (8c), which refers to beautiful people who are usually dancing:

- (8) (a) $\lambda y. \text{GEN}[e, x](x \text{ in } e \wedge y = x, \underline{\text{dance}}'(x)(e))$
 (b) $\lambda y. \text{GEN}[e, x](x \text{ in } e \wedge y = x, \underline{\text{dance}}'(x)(e) \wedge \text{beautiful}'(e))$
 (c) $\lambda y. \text{GEN}[e, x](x \text{ in } e \wedge y = x, \underline{\text{dance}}'(x)(e) \wedge \text{beautiful}'(y))$

2.2 Indefinite pronouns

For *something blue*, the semantic representations are (9a) for the modified expression (set of properties that some thing has), and (9b), for the whole expression (set of properties that some blue thing has). Once more one can derive the semantics for the whole expression by pertaining the modifier semantically only to a part of the semantics of the modified expression, viz., the restriction of the quantifier, which is

⁵This term refers to states of affairs of all kinds; following Davidson (1967), verbs and their projections have an additional eventuality arguments in their semantics.

underlined in (9a). In fact, there is no other alternative, since the modifier semantics is a function from individual sets to individual sets and the pronoun semantics, a set of individual sets. (5a) works analogously.

- (9) (a) $\lambda P \exists x. \underline{\text{thing}}'(x) \wedge P(x)$
 (b) $\lambda P \exists x. \text{thing}'(x) \wedge \text{blue}'(x) \wedge P(x)$

2.3 Modifiers

Next, I will show that Kasper's analysis is just another instance of this syntax-semantics mismatch. The semantics of *potentially* is (10a), which maps properties P on the property of being potentially P . Here $\diamond p$ is true in a world w iff p is true in some possible world. Following Kasper, this modifier of the adjective does not pertain to the whole ('attributive') semantics of the adjective (10b), a function from properties P to the intersection of P with the property of being controversial, but only to its 'predicative' part (the underlined property **controversial'**). This returns the desired semantic representation (10c) for (6a), a functor intersecting properties P with the property of being potentially controversial. Note that in this representation the $\hat{\lambda}$ -abstracted property P (which eventually emerges as the semantics of the noun modified by *potentially controversial* as in (6b)) is outside the scope of the diamond operator \diamond .

- (10) (a) $\lambda P \lambda x. \diamond (\wedge P(x))$
 (b) $\lambda P \lambda x. \underline{\text{controversial}}'(x) \wedge P(x)$
 (c) $\lambda P \lambda x. \diamond (\wedge \text{controversial}'(x)) \wedge P(x)$

The goal of this section was to outline my claim that the presented phenomena are all instances of the same syntax-semantics mismatch. The next section is devoted to previous approaches to these phenomena.

3 Previous analyses of the data

This section discusses previous approaches to the three phenomena outlined in the previous sections. These approaches concentrated on one phenomenon in isolation each and did not attempt to generalise the proposed analyses.

3.1 Agentive nouns: Larson (1998)

The modification of agentive nouns was discussed in Larson (1998). He accounts for agentive modification in terms of a suitable underlying syntactic structure. (11) is assigned the semantic representation (12) in his analysis:

- (11) Olga is a beautiful dancer

(12) $\Gamma e[\text{Con}(\text{olga}', e) \wedge \text{dance}'(\text{olga}', e)] [\text{beautiful}'(e)]$

' Γe ' is a generic quantifier for eventualities, 'Con' holds for an individual x and an eventuality e iff e is contextually relevant and contains x . In prose, (12) means that usually contextually relevant eventualities where Olga dances are beautiful.

The derivation of (12) is based on the syntactic structure (13):

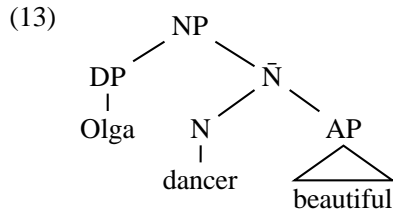

(13) is only a part of Larson's syntax tree for (11), viz., the main part of the complement of *be*. As the subject of the predicate nominal *dancer*, *Olga* occupies SpecN (Chomsky, 1995). To receive case and to agree with the finite verb and the adjective, it moves to the specifier position of the AgrSP. (AgrS is the functional head for subject-verb agreement.) Attributive adjectives follow their head nouns.

(12) is derived from (13) in the style of Diesing's (1992) *Mapping Hypothesis*, where the scope of a strong quantifier is determined by lower material in a syntax tree, its restriction, by higher material: The scope of the generic quantifier (which is contributed by *dancer*) is determined by the AP, and its restriction, by the rest of the syntax tree, which yields (12). I.e., the semantics of *dancer* comprises both $\text{Con}(x, e)$ and $\text{dance}'(x, e)$. (*Olga* is an argument of *dancer*, hence, in the derivation of (12) the meaning of *dancer* applies to the meaning of *Olga*.)

But this begs the question of how Larson would derive the semantic representation (15) for (14) from the syntax tree (16). His interpretation of (14) is that usually contextually relevant eventualities (where Olga is a participant) are eventualities where Olga dances:

(14) Olga is a dancer

(15) $\Gamma e[\text{Con}(\text{olga}', e)] [\text{dance}'(\text{olga}', e)]$

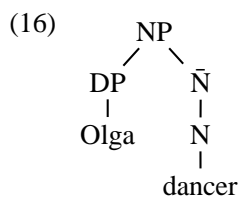

It is unclear how to derive (15) from (16) by the Mapping Hypothesis. In particular, it seems difficult to derive the fact that in this example, the semantics of the noun must provide both the restriction and the scope for the generic quantifier.

3.2 Indefinite pronouns: Abney (1987)

For the case of the indefinite pronouns, several *movement analyses* have been proposed, e.g., Kishimoto (2000) und Abney (1987), the latter of which will be sketched in the following. Abney puts down these pronouns to an *incorporation* of a nominal head (*-body, -thing* etc.) into a determiner head as the result of head-to-head movement. The nominal head can be modified just like any other noun but is enclitic, i.e., must find itself a host to attach to. E.g., he gives the following syntactic structure for (5b):

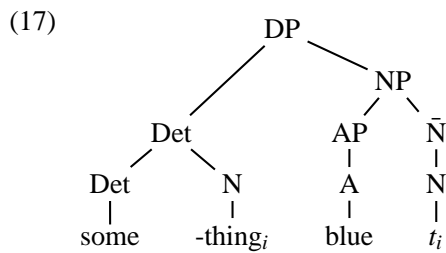

If we assume that the structure before movement is relevant for semantic construction, the desired semantic representation of (5b) follows immediately.

A potentially problematic prediction of this analysis is that it presupposes *morphological transparency* of the pronoun, which works out for English, but not for languages like German, whose indefinite pronouns (e.g., *jemand* ‘someone’ or *etwas* ‘something’) are morphologically opaque. In addition, the analysis must stipulate that words like *one* or *body* are ambiguous between a free and a bound variant with considerably different interpretations.

3.3 Modifiers: Kasper (to appear)

Finally, I will discuss Kasper’s analysis of the modification of modifiers. He divides the attributive meaning of a modifier into its predicative meaning (‘inherent content’, IC) and the rest (‘combinatorial semantics’, CS). Modifiers lexically determine the semantics *S* of the head-adjunct phrase in which they are the head of the adjunct: Their CS specifies the way in which *S* is composed from the semantic contributions of head and adjunct (e.g., for *controversial*, in an intersective fashion).

However, their own semantic contribution (their IC) cannot fully determine the semantics *S* of the adjunct as a whole, since the adjunct might be a head-adjunct phrase itself, as in (6b). Here the IC is not the one of its head *controversial*, instead, it is the one of *potentially*.

A modifier *M* of a modifier *M* should now affect only the IC of *M*. This happens in the usual fashion in that the semantics of *M'* is also the semantics of this local head-adjunct structure. E.g., for *potentially controversial*, the semantics is the one of *potentially*. In contrast, the CS of *M* must percolate to the phrase headed by *M*. Thus, the CS of *potentially controversial* is the one of *controversial*.

The implementation of this analysis relegates the CS of a modifier to a MOD feature ECONT, while its IC is the value of its CONT feature. In addition, the semantics S of the phrase headed by M shows up in a MOD feature ICONT. The ‘traditional’ MOD feature is now MOD|ARG. For instance, the relevant part of the lexical entry for *controversial* is (18):

$$(18) \left[\begin{array}{l} \text{HEAD|MOD} \\ \text{CONT} \end{array} \left[\begin{array}{l} \text{ARG|CONT} \left[\begin{array}{l} \text{INDEX } \boxed{1} \\ \text{RESTR } \boxed{2} \end{array} \right] \\ \text{ICONT|RESTR } \boxed{3} \\ \text{ECONT} \left[\begin{array}{l} \text{INDEX } \boxed{1} \\ \text{RESTR } \boxed{2 \cup 3} \end{array} \right] \\ \text{INDEX } \boxed{1} \\ \text{RESTR } \left\{ \left[\begin{array}{l} \text{RELN } \text{ controversial} \\ \text{INST } \boxed{1} \end{array} \right] \right\} \end{array} \right] \right]$$

The ECONT value is specified lexically, but the ICONT value is not. In particular, it is not equated with M 's semantic contribution as specified in its own CONT value. Being head features, ECONT and ICONT percolate from M to the phrase headed by M . This percolation is not affected by modification of M itself, which may only replace the CONT value of M by its own CONT value.

The semantics principle then determines the meaning of a head-adjunct phrase as the adjunct's CS by coindexing the CONT value of the phrase with the MOD|ECONT value of the adjunct. In addition, the MOD|ICONT value of the adjunct is coindexed with its CONT value. I.e., once a modifier has been projected to a full phrase (a precondition for its function as an adjunct in a head-adjunct structure), its current CONT value is identical to the semantics of the whole phrase (the ICONT value), because the phrase cannot be extended any further.

Kasper's analysis of (6b) is sketched in a slightly adapted form in (19):

(19)

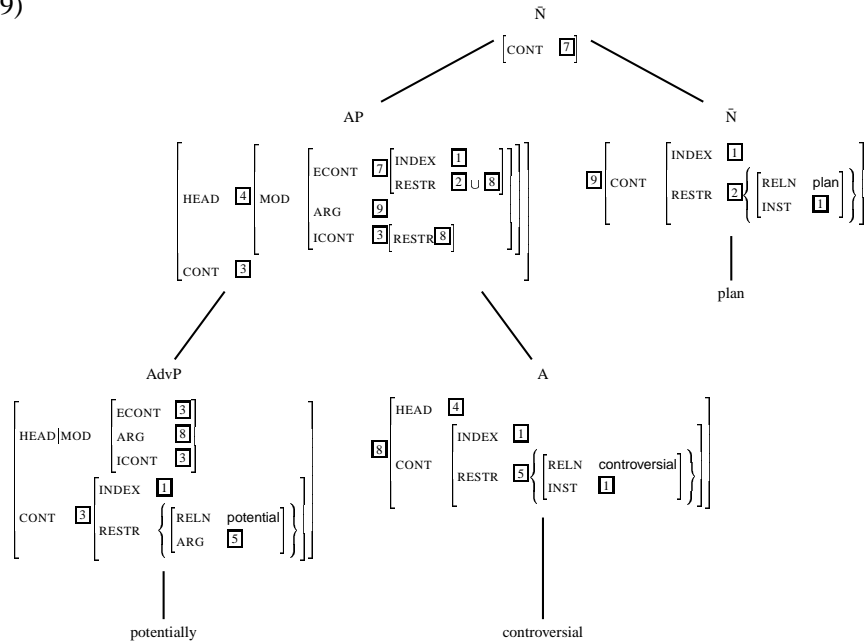

The semantics principle applies twice in this derivation, once for either head-adjunct structure. Its first application determines the \bar{N} semantics as the ECONT value [7] of the AP. The restriction of this ECONT value is defined in the head feature [4] of the lexical entry for *controversial* as the union of the restrictions of the modified noun [2] and of the semantic contribution [8] of the AP as a whole (as specified in its ICONT value [3]), respectively. The first application of the semantics principle also identifies the AP's ICONT and CONT values [3].

The second application of the semantics principle defines the AP's CONT value [3] as the ECONT value of the adverbial. Since the adverbial takes scope over the expression it modifies, its ECONT and ICONT values are identical. Due to the second application of the semantics principle, the ICONT value of the adverbial is equated with its CONT value. Thus, [8] is identified as the adverbial's restriction, where the potential-relation has the CONT|RESTR value [5] of the adjective as its argument.

In sum, the semantics [7] of the whole expression emerges as an intersection of the noun semantics and the semantics of the *adverbial*, the adjective semantics is the argument of the adverbial semantics.

There are two points worth noting for Kasper's analysis. First, it predicts that if a modifier may pertain semantically to only part of the expression it modifies syntactically, it must do so. But cases like (3) differ in this respect, i.e., the analysis cannot be generalised to capture the common ground between (3) and (6). Second, Kasper's interface machinery is designed for modification of modifiers, as it heavily uses the MOD feature. This begs the question of how to extend the scope of the analysis to the other phenomena presented in the preceding sections. In section

5, I will propose an analysis of the mismatch that is more flexible than Kasper’s yet preserves his insights. Here the mismatch is handled locally within the CONT feature of linguistic signs.

4 The semantic representation formalism

This section introduces the representation formalism in which my own analysis of the presented syntax-semantic mismatches is cast. The semantic description of these mismatches calls for a suitable *underspecification formalism*, e.g., UDRT (Reyle, 1993), MRS (Copestake et al., 2003), or Constraint Language for Lambda Structures (Egg et al., 2001) (used in an abbreviated form here). Expressions of such a formalism are *constraints* that describe a set of semantic representations (here, λ -terms), one for each reading of a structurally ambiguous expression. Constraints are underspecified in that they deliberately abstract away from the differences between their solutions (in particular, w.r.t. scope relations between the fragments). These formalisms allow an adequate representation of structural ambiguity and, what is more, they provide the necessary flexibility in the SSI.

Representations described by (or compatible with) a constraint are its *solutions*. Here we only need *constructive* solutions consisting of the material explicitly mentioned in the constraint. In this case, constraints can be regarded as a kind of jigsaw puzzle: Parts of a semantic representation are given together with some instructions on how to put them together. Any possible way of putting them together yields one of the solutions of the constraint.

I will now outline the proposed solution with the semantic representation and construction for (6a) in the simplified form of CLLS employed in this paper. The constraint for its meaning is (20). In such constraints, ‘[[C]]’ indicates the main fragment of a constituent C and ‘[[C_S]]’, the secondary fragment of C. ‘[[C]]:F’ expresses that the main fragment of C is defined as fragment F:

$$(20) \quad \begin{array}{ccc} & & \text{[[AP]]} : \square \\ & \text{[[AP_S]]} : \lambda P \lambda x. \square.(x) \wedge P(x) & \lambda x. \diamond (\wedge \square(x)) \\ & & \text{controversial!} \end{array}$$

(20) comprises the three ingredients out of which the simplified CLLS expressions are constructed, viz., fragments of λ -terms, not yet known parts of these fragments, indicated by ‘holes’ (\square), and *dominance relations* (depicted by dotted lines) that relate fragments to holes. When a fragment is dominated by a hole it is an (im-)proper part of whatever the hole stands for. Dominance relations model scope. Structures like (20) are called *dominance diamonds*. (They are characteristic for quantifier scope ambiguities, too, see section 5 below.)

To paraphrase (20), we do not know what the structure as a whole stands for

(thus, there is only a hole on top) but both the semantic contribution of the modifier (the right fragment) and the combinatorial semantics of the adjective (the left fragment) are its immediate parts. In addition, the adjective's inherent content (the bottom fragment) has narrowest scope, as it is dominated by the other two fragments.

Resolving the ambiguity in constraints is modelled as adding information monotonically, in particular, by strengthening dominance relations between holes and fragments to *identity*. For (20), there are in principle two choices: Identifying the CS fragment with the top hole, the modifier fragment, with the hole in the CS fragment, and the IC fragment, with the hole in the modifier fragment yields (10c). The other choice (starting this procedure with the modifier fragment) is blocked due to the types of the involved fragments: The hole in the modifier fragment cannot be identified with the CS fragment. I.e., there is no danger of unwanted overgeneration for the cases of modification of modifiers (neither for indefinite pronoun cases like (5)), while for ambiguous cases like (3) both choices would return a solution of the constraint. See the bottom of section 5 for the semantic representations of these cases.

5 The proposed analysis

The pivot of my analysis is the syntax-semantics interface. It models the discussed anti-iconic structures as *potential scope ambiguities*. The basic assumption is that the semantic contribution of a (lexical or complex) constituent *C* breaks down into a *secondary part* (which ends up in the scope of all constituents that unilaterally c-command *C*) and a *main part*, whose scope is determined differently. The rules of the syntax-semantics interface can handle *both kinds* of fragments, therefore the analysis can be based on a very *surface-oriented* syntactic structure. Thus, when *C* is modified, the modifier outscopes *C*'s secondary part semantically, but the scope between the modifier and *C*'s main part is deliberately left open. E.g., for *controversial* its inherent content constitutes the secondary, and its combinatorial semantics, the main part of its semantic contribution. Consequently, in the semantics of *potentially controversial*, the adverbial outscopes the IC of *controversial*, but the scope of its CS and the adverbial is open. Wide scope of the former is possible, which yields the desired interpretation (10c) for (6a).

The resulting expressions of the semantic formalisms thus look just like the expressions that model sentences with two scopally ambiguous quantifying NPs. Here the bottom fragment of the dominance diamond comprises the verb that syntactically subcategorises for the scope-bearing NPs. The two NPs contribute the two scopally ambiguous fragments of the diamond. See Egg et al. (2001) or Reyle (1993) for details.⁶

⁶Note that the kind of elaborated syntax-semantics interface that is needed to derive the semantic representations for the phenomena which are analysed in this paper is also required to derive these representations for quantifier scope ambiguities. I.e., the proposed treatment of these phenomena

5.1 The syntax-semantics interface

The interface derives the constraint (20) from the syntactic structure for (6a), which is (21):

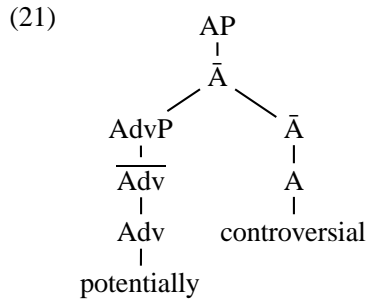

Deriving constraints like (20) uses lexical entries as the one of *controversial*. Here the inherent content of the adjective, which modifiers might pertain to exclusively, is set off in a fragment $[[A_S]]$ of its own. The combinatorial semantics of the adjective constitutes the $[[A]]$ fragment:

(22)

$$\begin{array}{l}
 [[A]] : \lambda P \lambda x. \Box(x) \wedge P(x) \\
 \vdots \\
 [[A_S]] : \text{controversial}'
 \end{array}$$

This kind of semantic information is encoded in the *CONT* feature of linguistic signs. Its value, a feature structure of type *cont*, has a list-valued feature *CONSTR* for the constraint itself. Two auxiliary features *FST* and *SND* identify main and secondary fragment of a constituent among the fragments appearing in *CONSTR* (fragments can be modelled by feature structures, too):

(23)

$$\text{cont} \left[\begin{array}{ll}
 \text{FST} & \boxed{1} \\
 \text{SND} & \boxed{2} \\
 \text{CONSTR} & \langle \dots \boxed{1} \dots \boxed{2} \dots \rangle
 \end{array} \right]$$

First of all, a constituent inherits the constraints Con_1 and Con_2 of its immediate constituents C_1 and C_2 . The interface rules specify for each constituent C how Con_1 and Con_2 are combined into a new constraint Con for C . Rules are implemented as phrases that may themselves contribute to Con . They combine Con_1 and Con_2 via the *FST* and *SND* values of C_1 and C_2 and determine these features for C . This kind of semantic construction is familiar e.g. from semantic construction in MRS (Copestake et al., 2003).

As an introduction to the way in which these rules are written, consider the (trivial) rule that nonbranching \bar{X} constituents inherit their fragments from their

does not introduce additional complexity into the syntax-semantics interface.

heads. Recall that ‘[[C]]’ stands for the main and ‘[[C_S]]’, for the secondary fragment of a constituent C; ‘[[C]]:F’ indicates that the main fragment of C is defined as F:

$$(24) \quad [\bar{x} \bar{x}] \quad \xRightarrow{\text{(SSS)}} \quad [[\bar{x}]] : [[x]] \quad [[\bar{x}_S]] : [[x_S]]$$

The modification interface rule is (25): The emerging constituent \bar{x}_1 inherits its main fragment $[[\bar{x}_1]]$ from the modified expression. Its secondary fragment $[[\bar{x}_{1S}]]$ is defined as the modifier fragment $[[\text{Mod}]]$ applied to a hole that dominates the secondary fragment $[[\bar{x}_{2S}]]$ of the modified expression. This makes $[[\text{Mod}]]$ and $[[\bar{x}_1]]$ scopally ambiguous and yields the bottom half of a dominance diamond. Recall that $[[\bar{x}_2]]$ dominates $[[\bar{x}_{2S}]]$ (they are fragments of the same constituent) and is equal to $[[\bar{x}_1]]$. Equating the modifier fragments ($[[\text{Mod}]] : [[\text{Mod}_S]]$) is not necessary, but facilitates reading.

$$(25) \quad [\bar{x}_1 \text{Mod} \bar{x}_2] \quad \xRightarrow{\text{(SSS)}} \quad \begin{array}{c} [[\bar{x}_{1S}]] : [[\text{Mod}]](\square) \\ \vdots \\ [[\bar{x}_{2S}]] \end{array}$$

$$[[\text{Mod}]] : [[\text{Mod}_S]] \quad [[\bar{x}_1]] : [[\bar{x}_2]]$$

Finally, the rule that constructs the upper half of the dominance diamond corresponds to the syntax rule that \bar{x} constituents may by themselves constitute XPs of their own. The main fragment of XP is only a hole that dominates both fragments of the \bar{x} constituent:

$$(26) \quad [_{XP} \bar{x}] \quad \xRightarrow{\text{(SSS)}} \quad \begin{array}{c} [[XP]] : \square \\ \vdots \\ [[XP_S]] : [[\bar{x}]] \end{array} \quad \dots \quad [[\bar{x}_S]]$$

5.2 Analyses of the syntax-semantics mismatches

Semantic construction for *potentially controversial* now uses the lexical entries for *controversial* (22) and *potentially* (27) and the rules (24)-(26) to derive the diamond in (20) on the basis of (21).

$$(27) \quad [[\text{Adv}]], [[\text{Adv}_S]] : \lambda P \lambda x. \diamond (\wedge P(x))$$

In the lexical entry for *potentially*, both fragments are identical; according to (24), this carries over to *potentially* as $\bar{\text{adv}}$ constituent. Following (26), the constraint for the AdvP *potentially* is (28):

$$(28) \quad \begin{array}{c} [[\text{AdvP}]] : \square \\ \vdots \\ [[\text{AdvP}_S]] : \lambda P \lambda x. \diamond (\wedge P(x)) \end{array}$$

Next, (25) combines (22) and (28) into (29), the bottom half of a diamond for the meaning of the \bar{A} constituent *potentially controversial*, before (26) transforms (29) into the full diamond (20).

$$(29) \quad \begin{array}{ccc} \llbracket \bar{A} \rrbracket : \lambda P \lambda x. \Box(x) \wedge P(x) & & \llbracket \bar{A}_S \rrbracket : \lambda x. \diamond (\wedge \Box(x)) \\ & \text{controversial}' & \end{array}$$

The semantics of *beautiful dancer* is derived analogously. It is based on the lexical entry for the semantics of *dancer* (30)⁷ and a simple lexical entry for *beautiful*, which is given in (31):⁸

$$(30) \quad \begin{array}{c} \llbracket N \rrbracket : \lambda y. \text{GEN}[e, x](x \text{ in } e \wedge y = x, \Box(e)) \\ \vdots \\ \llbracket N_S \rrbracket : \mathbf{dance}'(x) \end{array}$$

$$(31) \quad \llbracket A \rrbracket, \llbracket A_S \rrbracket : \lambda P \lambda x. P(x) \wedge \mathbf{beautiful}'(x)$$

The resulting dominance diamond (32) has *two solutions*, viz., (8b) and (8c).

$$(32) \quad \begin{array}{ccc} & \llbracket NP \rrbracket : \Box & \\ & \vdots & \\ \llbracket NP_S \rrbracket : \lambda y. \text{GEN}[e, x](x \text{ in } e \wedge y = x, \Box(e)) & & \lambda y. \Box(y) \wedge \mathbf{beautiful}'(y) \\ & \mathbf{dance}'(x) & \end{array}$$

Finally, the dominance diamond for the indefinite pronoun cases emerges from lexical entries for these pronouns where the restriction of the quantification constitutes the secondary fragment of the determiner, e.g., for *something*:

$$(33) \quad \begin{array}{c} \llbracket D \rrbracket : \lambda P \exists x. \Box(x) \wedge P(x) \\ \vdots \\ \llbracket D_S \rrbracket : \mathbf{thing}' \end{array}$$

With the rules (24)-(26) and a simple lexical entry for *blue* (in analogy to (31)) we can derive the semantic representation (34) for *something blue*:

⁷This twopartite semantic structure can be derived by a rule of the morphology-semantics interface which combines the stem and the affix semantics. This rule is described as (41) in section 6 below.

⁸Here and in the following the distinction between the combinatorial semantics and the inherent content of the adjective is of no avail, hence, neglected.

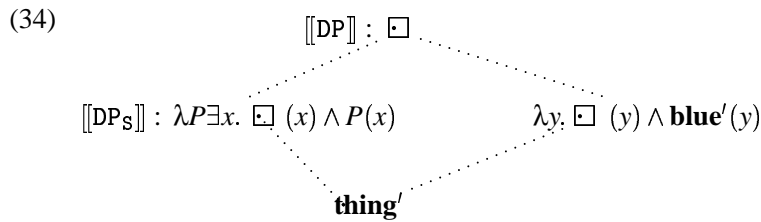

Just like for the case of the modification of modifiers, the scope ambiguity as expressed in the dominance diamond is only a potential one, because the fragments can only be put together in one specific way. In (34) the right fragment can be identified with the hole in the left fragment but not the other way round, which yields as the sole solution the desired λ -term (9b). I.e., once again the analysis does not lead to unwanted overgeneration.

This concludes the presentation of the proposed analysis, whose goal was a uniform semantic construction for mismatches at the syntax-semantics interface on the basis of a surface-oriented syntactic structure.

6 Conclusion and outlook

Syntax-semantics mismatches in modification structures that involve agentive nouns, indefinite pronouns, or modifiers that are modified themselves, have been analysed in terms of *potential scope ambiguities*. This analysis can be extended to capture additional, seemingly unrelated phenomena. In the remainder of the paper I will show that the morphosemantic mismatches noted by Lüdelling (2001) and discussed by Müller (2003) under the heading of ‘bracketing paradoxes’ can be analysed as one more instance of the mismatch, though, this time, the mismatch affects the morphology-semantics and not the syntax-semantics interface.

Consider e.g. separable prefix verbs like *losrennen*:

- (35) los- renn -en
start run infinitive
 ‘to start running’

In nominalisations of these verbs by the *Ge...e* circumfix, which expresses iteration semantically, only the verb stem shows up within the circumfix (thus, for *losrennen* the nominalisation is (36)). In the gloss, the two parts of the circumfix are distinguished by subscripts:

- (36) Los- ge- renn -e
start iter_nom₁ run iter_nom₂
 ‘iteration of events of starting to run’

This suggests a morphological structure in which the verb stem combines with the circumfix *before* the prefix is attached: In the other option (combining the

circumfix x with the prefixed verb stem) the prefixation would have to be undone again in order to get the position of the circumfix x around the verb stem only right.

But if we assume that the order of morphological combination fixes the semantic scope of the operators, the prefix x should have scope over the circumfix x . However, this prediction is not borne out, the scope of the affixes is exactly the other way round, which constitutes a morphology-semantics mismatch. I.e., in the case of *Losgerenne* the prefix x is in the scope of the circumfix x , thus, the nominalisation refers to iterations of eventualities of starting to run (and not the start of an iteration of running eventualities).

This problem is yet another instance of the sort of mismatch discussed in this paper. To see this, consider the following reformulation of the problem: The semantics of *Gerenne* is (37a), in prose, the set of eventualities e such that e is an iteration of eventualities where some x runs. From this semantic representation we can obtain the semantics of *Losgerenne* by pertaining the prefix x meaning (mostly, the change-of-state operator BECOME) not to the semantics of the base (37a) as a whole, but only to that part of it that is contributed by the verb stem (plus argument binding), which is underlined in (37a). The resulting (37b) stands for the set of iterations of eventualities where some x starts to run:

- (37) (a) $\lambda e. \text{ITER}(\lambda e' \exists x. \underline{\text{run}}'(x)(e'))(e)$
 (b) $\lambda e. \text{ITER}(\text{BECOME}(\lambda e' \exists x. \underline{\text{run}}'(x)(e')))(e)$

The two operators ITER and BECOME in (37) are defined in the following way. ITER relates properties of eventualities P to eventualities e if e is the convex union (i.e., including anything in between) of a set of eventualities E , each of whose elements is a P -eventuality. In addition, e itself may not be a P -eventuality (38a). The definition of BECOME in (38b) is basically the one of Dowty (1979):

- (38) (a) $\forall P \forall e. \text{ITER}(P)(e) \leftrightarrow \exists E. \forall e'. e' \in E \rightarrow P(e') \wedge \bigcup E = e \wedge \neg P(e)$
 (b) $\text{BECOME}(P)(e)$ iff e is preceded by an eventuality for which $\neg P$ holds and is succeeded by a P -eventuality and there is no smaller eventuality e' that also fulfills the first two conditions

Müller's solution analyses prefixes like *los-* as *subcategorised modifiers*. First, a lexical rule maps an ordinary verb stem like run_1 (the suffix is used for expository reasons) onto a stem run_2 , which subcategorises for a separable prefix as a modifier. The prefix semantics becomes the semantics of the resulting stem run_2 . It specifies how the semantic contributions of the prefix and the stem run_1 are combined into the semantics of the stem run_2 . Thus, the semantics of the stem run_2 can be paraphrased as 'prefix semantics (whatever that may be) applied to the semantics of run_1 '. The semantics of run_1 is lexically given.

Next run_2 undergoes nominalisation by circumfixing $Ge \dots e$, which yields *Gerenne*. But in this noun, the subcategorisation for the prefix remains. The paraphrase of the semantics of *Gerenne* is 'ITER applied to run_2 semantics' (i.e., 'ITER

applied to the prefix semantics (whatever that may be) applied to *run*₁ semantics’). The final step then is the determination of the prefix semantics to the operator BECOME after the subcategorisation for a prefix has been saturated by *los*-.

However, as soon as one would try to generalise this solution to modification in general (something which Müller doesn’t do, but which might be one way of capturing the common ground between his examples and the data discussed in the main part of this paper), the result would be massive ambiguity in the lexicon. E.g., *dancer* would have to be ambiguous between the standard reading and another reading that subcategorises for a modifier. (This subcategorisation would be inherited from a reading of *dance* that is derived from Müller’s lexical rule.) This second reading of *dancer* would have the following semantics, where the λ -abstracted property *P* is eventually identified with the modifier semantics:

$$(39) \quad \lambda P \lambda y. \text{GEN}[e, x](x \text{ in } e \wedge y = x, \mathbf{dance}'(x)(e) \wedge P(e))$$

But instead of trying to generalise Müller’s solution to the other data presented in this paper, I will implement the insight that this morphology-semantics mismatch can be analysed in analogy to the account of the syntax-semantics mismatches advocated in this paper.

The implementation follows the crucial observation sketched in (37), viz., that the semantic effect of prefixation resembles the effect of modification in examples like (3) and (5). This suggests handling prefixation at the morphology-semantics interface in a fashion close to the (syntax-semantics) interface rule (25).

The rule that builds the semantic representations for affixed nouns, e.g., (40) [= (30)] for *dancer*, is given as (41):

$$(40) \quad \llbracket \mathbf{N} \rrbracket : \lambda y. \text{GEN}[e, x](x \text{ in } e \wedge y = x, \square(e))$$

$$(41) \quad \llbracket \mathbf{X} \text{ Bs Aff} \rrbracket \xrightarrow{\text{morph}} \begin{array}{c} \llbracket \mathbf{N}_S \rrbracket : \mathbf{dance}'(x) \\ \llbracket \mathbf{X} \rrbracket : \llbracket \mathbf{Aff} \rrbracket(\lambda \vec{y}. \square) \\ \llbracket \mathbf{X}_S \rrbracket : \llbracket \mathbf{Bs}_S \rrbracket(\vec{y}) \end{array}$$

In close analogy to the modification rule (25), (41) assigns affixed expressions a structured semantic representation where the main fragment of the affix dominates the secondary fragment of its base. Scope between the main fragments of base and affix is in principle open; for bases that are roots it is fixed, however, when the main and secondary fragments coincide for these roots. (40) is constructed by (41) from the semantic contribution (7a) of the affix and the semantics of *dance* (\mathbf{dance}' , which relates eventualities and individuals).

However, the analogy between (25) and (41) is not complete in that (41) defines the main fragment of the affix as the main fragment of the resulting word and the secondary fragment of the base as the resulting word’s secondary fragment.

What is more, interface rules for affixation must take into account *argument binding*. The fact that affixes may bind arguments of their base is anticipated in rule (41) in that the individual arguments of the stem are λ -abstracted in the main fragment, which allows binding by the affix. It is then the task of the affix to determine how many arguments are bound; while *-er* binds everything but the agentive argument and *Ge...e*, every argument of its base, semantically transparent prefixes like *los-* inherit all individual arguments from their bases. (See the corresponding semantic representations of the affixes (7a), (42), and (45).)

Note that in (41) the category of the base ('Bs') and of the resulting expression ('x') are left open. In addition, the rule does not predict the ordering of affix and base. This kind of information must be supplied by the affixes themselves, it is not part of the interface rule. E.g., *Ge...e* and *-er* map verbal bases to nouns, while *los-* maps nominal or verbal bases to expressions of the same category.

I will now outline the derivation of the semantics of *Losgerenne*. First, the semantics of the circumfix *Ge...e* maps n -ary relations P between an eventuality and $n - 1$ individuals to the property of being an iteration of P - eventualities (with possibly different participants):

$$(42) \quad \lambda P \lambda e . \text{ITER}(\lambda e' \exists \vec{x} . P(\vec{x})(e'))(e)$$

Semantic construction for *Gerenne* builds on (42) and a simple lexical entry for the verbal root *renn-* 'run':

$$(43) \quad \llbracket \text{V} \rrbracket , \llbracket \text{V}_S \rrbracket : \lambda x \lambda e . \text{run}'(x)(e)$$

(42) and (43) are combined into the semantic representation (44) for *Gerenne* by rule (41):⁹

$$(44) \quad \llbracket \text{N} \rrbracket : \lambda e . \text{ITER}(\lambda e' \exists x . \boxed{}(e'))(e)$$

\vdots
 $\llbracket \text{N}_S \rrbracket : \lambda e . \text{run}'(x)(e)$

Another application of rule (41) builds the semantics of *Losgerenne* from the semantics of *los-* (45) and (44). (45) maps n -ary relations P onto the n -ary relation which involves the same individual arguments and the begin of a P -eventuality.

$$(45) \quad \lambda P \lambda \vec{x} \lambda e . \text{BECOME}(P(\vec{x}))(e)$$

$$(46) \quad \llbracket \text{N} \rrbracket : \lambda e . \text{BECOME}(\boxed{})(e) \qquad \lambda e . \text{ITER}(\lambda e' \exists x . \boxed{}(e'))(e)$$

\vdots
 $\llbracket \text{N}_S \rrbracket : \lambda e'' . \text{run}'(x)(e'')$

⁹Note that the semantic representation (44) for *Gerenne* is also adequate as the input for the semantic construction of *schnelles Gerenne* in terms of rule (25), which may refer to iterations of fast runnings, i.e., the iteration itself need not be fast. This interpretation, where the modifier pertains only to the stem of its modified expression, is adequately captured by pertaining the modifier *schnell* to the embedded fragment of the semantic of *Gerenne* (which comprises the stem semantics).

Affixation of *Gerenne* by *los-* introduces an additional fragment for *los-* (with the change-of-state operator BECOME) that dominates the verb stem semantics but not the fragment for the circumfix on the right. I.e., narrow scope of BECOME with respect to ITER is possible according to (46).

Finally, we have to explain why narrow scope of BECOME is not only possible but indeed necessary. Here my intuition on the semantics of (productive and semantically transparent) *los-* is that it requires its argument to refer to an eventuality that involves a *maximal axis* in the sense of Lang (1990). For instance, *los-* attaches easily to movement verbs (*loslaufen* ‘start walking’, *losrollen* ‘start rolling’ [intransitive]) or even weather verbs that involve movement (*loshageln* ‘start hailing’, *losregnen* ‘start raining’) in contrast to other weather verbs (**losfrieren* ‘start freezing’). Since an iteration of running eventualities as opposed to these eventualities themselves does not involve such a maximal axis, the sole resolution of (46) is the one where the right fragment receives widest scope, which yields the desired semantic representation (37b) for *Losgerenne*.

In sum, the goal of this paper has been to substantiate my claim that there is considerable common ground between the syntax-semantics mismatches that were presented in this paper. This common ground calls for a unified analysis, which was then presented in the paper within a version of the syntax-semantics interface that is implemented as the CONT feature of HPSG signs. Finally, I motivated and sketched an extension of the analysis to a morphology-semantics mismatch for German separable-prefix verbs.

References

- Abney, Steve. 1987. *The English noun phrase in its sentential aspect*. Ph. D.thesis, MIT.
- Chomsky, Noam. 1995. *The minimalist program*. Cambridge: MIT Press.
- Copestake, Ann, Flickinger, Daniel, Pollard, Carl and Sag, Ivan. 2003. Minimal Recursion Semantics. An introduction, MS (revised version), CSLI Stanford.
- Davidson, Donald. 1967. The logical form of action sentences. In Nicholas Rescher (ed.), *The logic of decision and action*, pages 81–95, Pittsburgh: Pittsburgh University Press.
- Diesing, Molly. 1992. *Indefinites*. Cambridge: MIT Press.
- Dowty, David. 1979. *Word meaning and Montague grammar*. Dordrecht: Reidel.
- Egg, Markus, Koller, Alexander and Niehren, Joachim. 2001. The constraint language for lambda-structures. *Journal of Logic, Language, and Information* 10, 457–485.

- Kasper, Robert. to appear. The semantics of recursive modification. *Journal of Linguistics* .
- Kathol, Andreas. 1999. Restrictive modification and polycategorial NPs in English. In Gousse Bouma, Erhard Hinrichs, Geert-Jan Kruijff and Richard Oehrle (eds.), *Constraints and resources in natural language syntax and semantics*, pages 83–100, Stanford: CSLI Publications.
- Kishimoto, Hideki. 2000. Indefinite pronouns and overt N-raising. *Linguistic Inquiry* 31, 557–566.
- Kiss, Tibor. 1995. *Merkmale und Repräsentationen*. Westdeutscher Verlag.
- Krifka, Manfred, Pelletier, Francis, Carlson, Gregory, ter Meulen, Alice, Chierchia, Gennaro and Link, Godehard. 1995. Genericity: an introduction. In Gregory Carlson and Francis Pelletier (eds.), *The generic book*, pages 1–124, Chicago: University of Chicago Press.
- Lang, Ewald. 1990. Primary perceptual space and inherent proportion schema. *Journal of Semantics* 7, 121–143.
- Larson, Richard. 1998. Events and modification in nominals. In Devon Strolovitch and Aaron Lawson (eds.), *Proceedings from SALT VIII*, pages 145–168, Cornell University, Ithaca.
- Lüdeling, Anke. 2001. *On particle verbs and similar constructions in German*. Stanford: CSLI Publications.
- Müller, Stefan. 2003. The morphology of German particle verbs: solving the bracketing paradox. *Journal of Linguistics* 39, 275–325.
- Pollard, Carl and Sag, Ivan. 1994. *Head-driven Phrase Structure Grammar*. CSLI and University of Chicago Press.
- Reyle, Uwe. 1993. Dealing with ambiguities by underspecification: construction, representation, and deduction. *Journal of Semantics* 10, 123–179.
- Sag, Ivan. 1997. English relative clause constructions. *Journal of Linguistics* 33, 431–484.

Raising doubts about Russian impersonals

Jean-Pierre Koenig 

University at Buffalo, The State University of New York

Anthony R. Davis 

StreamSage, Inc.

Proceedings of the 11th International Conference on
Head-Driven Phrase Structure Grammar

Center for Computational Linguistics, Katholieke Universiteit Leuven

Stefan Müller (Editor)

2004

Stanford, CA: CSLI Publications

pages 140–150

Koenig, Jean-Pierre & Anthony R. Davis. 2004. Raising doubts about Russian impersonals. In Stefan Müller (ed.), *Proceedings of the 11th International Conference on Head-Driven Phrase Structure Grammar*, Center for Computational Linguistics, Katholieke Universiteit Leuven, 140–150. Stanford, CA: CSLI Publications. DOI: 10.21248/hpsg.2004.8. 

Abstract

The Russian data presented in Perlmutter and Moore (2002) seem to call into question the standard analysis of raising within Head-driven Phrase Structure Grammar (HPSG): In Russian, the case marking of the raising target and raising pivot does not seem to be shared. In this paper, we show that the phenomena described by Perlmutter and Moore can receive another analysis, fully compatible with HPSG's theory of raising. We argue in addition that our account leads to a slightly simpler model of the Russian data than Perlmutter and Moore's. Crucially, our analysis is only available if we avail ourselves of a rich network of language-specific constructional schemata, a stance recently advocated within HPSG, following the lead of Construction Grammar.

The Head-driven Phrase Structure Grammar analysis of raising, as presented in Pollard and Sag (1994), differs from other constraint-based lexicalist frameworks (e.g., Construction Grammar or Lexical-Functional Grammar)¹ in distinguishing between raising and control structures. In the case of control, only the index of the controller is identified with the index of the control target (making control an instance of binding). In the case of raising, the entire *synsem* of the raised NP or raising pivot is identical to the embedded predicate's subject argument's *synsem* or raising target. Thus, in Figure 1, which represents part of the lexical entry of raising verbs, the first member of the ARG-ST list (corresponding to the subject in Nominative-Accusative languages) is identified with the first member of the argument structure of the second member of the ARG-ST (the verbal complement), as indicated by \square . As a consequence, the case value of these two *synsems* must be identical (what we informally represented through an identically named variable x).

One advantage of this hypothesized difference between raising and control is that it immediately accounts for the transmission to the raising pivot of the quirky case assigned to the raising target by the embedded verb in languages like Icelandic (see Sag *et al.* (1992)). However, the Russian data presented in a recent paper (Perlmutter and Moore (2002)) seem to call this analysis into question. In Russian, the case marking of the raising target and raising pivot does not seem to be shared, contra the standard Head-driven Phrase Structure Grammar analysis (henceforth, HPSG). In this paper, we show that the phenomena described by Perlmutter and Moore can receive another analysis, fully compatible with HPSG's theory of raising. We argue in addition that our account leads to a slightly simpler model of the Russian data than Perlmutter and Moore's. Crucially, this analysis is only available if we avail ourselves of a rich network of language-specific constructional schemata, a stance recently advocated within HPSG, following the lead of Construction Grammar (see Sag (1997), Ginzburg and Sag (2001), and Kathol (2001), among others).

¹This is not true, though, of Categorical Grammar (e.g., Jacobson (1990) and work based on it), which aims to account for the same kinds of differences that the HPSG account focuses on.

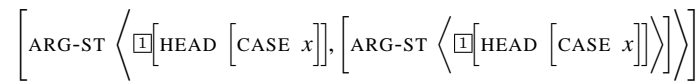

Figure 1: The (simplified) argument structure of a subject-to-subject raising verb

In the following section we present the Russian data from Perlmutter and Moore’s paper. We then present our analysis. In the conclusion we compare it with Perlmutter and Moore’s account, and speculate about which other phenomena typically treated in terms of lexical requirements might be more amenable to a constructional account.

1 The Russian data

Perlmutter and Moore’s paper is concerned primarily with the interaction of infinitival and impersonal constructions in Russian. Russian raising structures are only discussed to the extent they provide evidence for Perlmutter and Moore’s theory of zero expletives. But their analysis of raising, if correct, would challenge HPSG’s theory of raising structures. Perlmutter and Moore provide convincing evidence for the following generalizations about Russian:

- a. The subjects of infinitival clauses are datives. (Comrie (1974))
- b. Infinitival clauses must have an expressed subject.
- c. Impersonal clauses have a silent expletive subject.
- d. This subject must be in the nominative case.

Sentence (1) below illustrates the claim that the subject of infinitival clauses is dative (see Perlmutter and Moore’s paper for a list of infinitival clauses and their functions in Russian and Moore and Perlmutter (2000) for compelling evidence that the dative pronoun *mne* is indeed the subject of the infinitival verb). The sentences in (2) show that the complement of an *infinitival* purpose clause cannot leave its subject (here, *nam*) unexpressed, in contrast to that of *finite* purpose clauses (here, *my*). Finally, the contrast between sentences (3-a) and (3-b) shows that the expletive subject of impersonal clauses must be silent.

- (1) Mne ne sdat’ èkzamen
me-DAT NEG pass-INF exam-ACC
‘It’s not (in the cards) for me to pass the exam.’
- (2) a. čtoby (my) uexali na vokzal
in.order we-NOM go.out-SUBJUNCT to railway-station
‘in order that we go out to the railway station’

- b. čtoby *(nam) uexat' na vokzal
 in.order us-DAT go.out-INF to railway-station
 'in order for us to go out to the railway station'
- (3) a. Na Gavajax ne morozit.
 in Hawaii NEG freeze-3SG
 'It doesn't freeze in Hawaii.'
- b. *Na Gavajax ono ne morozit.
 in Hawaii it.NOM NEG freeze-3SG
 'It doesn't freeze in Hawaii.'

These four facts together entail that impersonal clauses cannot be infinitival, since the expletive subject of impersonals must be nominative and the subject of infinitival clauses must be dative. Interestingly, though, impersonal infinitival phrases *can* felicitously serve as complements of raising predicates, provided the “surface position” of the raised expletive is the subject of a finite clause (and hence receives nominative case). Sentence (4) illustrates this case. The raising verb *načalo* ‘begin’ takes a nominative subject, as is generally the case for finite forms of verbs. Since the raised expletive is now in a “position” in which it receives nominative case, generalization d. is not violated and the sentence is grammatical.

The grammaticality of example (4) contradicts the predictions of HPSG’s analysis of raising, at least if we adopt Perlmutter and Moore’s analysis of the Russian data. The case of the (unexpressed) expletive raising pivot is nominative, as is required of the subjects of impersonal clauses by generalization d. The case of the raising target must be dative, by generalization a. The *synsem* values of the raising pivot and target cannot therefore be structure-shared, as the HPSG analysis demands, because the values of their CASE attributes conflict.

- (4) Borisa načalo tošnit'.
 Boris-ACC began-NEUT nauseate-INF
 'Boris began to feel nauseous.'

2 It is not so bad, after all

Perlmutter and Moore’s data is not as damaging for the standard HPSG treatment of raising as it seems. As we show in this section, their analysis of the Russian data relies on an implicit assumption regarding the structure of Russian clauses. We show that a theoretically articulated theory of clause structure need not (in fact, should not) espouse this assumption.

2.1 Changing the underlying assumptions

The Russian data are entirely compatible with the HPSG analysis of raising, provided we do not subscribe to Perlmutter and Moore’s assumption that the infinitive

complement of raising verbs is a *clause* and that we restrict generalization a. to the *expressed* subjects of infinitival verbs. Generalization a., as Perlmutter and Moore express it, refers to an intuitive notion of clause, not spelled out in detail. It amounts to grouping together, as members of this pretheoretical notion of clause constructs of type *head-subject-phrase* (root clauses, questions, purpose and temporal clauses) and VPs with unexpressed subjects (complements of raising predicates and obligatorily controlled complements). Although many claim that these two classes of construct form a natural class (see Chomsky (1981) for a defense of this view), this hypothesis has been disputed by advocates of constraint-based lexicalist theories since at least Bresnan and Kaplan (1982) and Gazdar *et al.* (1985). Under this alternative, controlled complements are treated as subjectless XCOMPS or VPs. Independently of this general theoretical difference as to whether these two kinds of constructions are both instances of the category of clause, there is Russian-internal evidence that the two behave differently, as Perlmutter and Moore themselves implicitly admit. First, the (unexpressed) subject of the controlled VP sometimes takes the case of the controller. Sentence (5) illustrates this pattern. The secondary predicate *sam* ‘alone’ agrees in case with the controller of the unexpressed subject of the VP *pojti na večerinku*, namely *Ivan*.

- (5) Ivan xočet [PRO pojti na večerinku sam]
 Ivan.M.NOM want PRO to.go to party alone.M.NOM
 ‘Ivan wants to go to the party alone.’ (From Franks (1995))

Second, the subject of the VP complement of the raising predicate takes the case of the raising pivot, as sentence (4) illustrates.

To reflect the difference between the two kinds of infinitival “clauses” Perlmutter and Moore discuss, we modify generalization a. as a’ below, and add the hypothesis in e. Under our alternative analysis, descriptive generalization b. receives a different interpretation than that of Perlmutter and Moore. We model generalization b. as the effect of a constraint on the type *head-subject-phrase*, not as a property of all maximal projections headed by an infinitival verb.

- a’. The *expressed* subjects of infinitival clauses are datives.
 e. Root, question, purpose, and temporal clauses are *head-subject-phrases*; the complement of raising verbs is a VP, i.e. either a *head-complement-phrase* or a *head-adjunct-phrase* (standard HPSG fare).

As the next section demonstrates, this revised, narrower generalization is all that is needed to bring the Russian data in compliance with the HPSG analysis of raising.

2.2 The technical details

We model the Russian data with three constraints, which account for generalizations a’ through e. above.

Constraint (6) models generalization c.² It says that any impersonal verb (a member of the category of lexemes denoted by the type *impersonal-verb*) subcategorizes for an unexpressed expletive subject (i.e. a subject whose semantic CONTENT is *expletive* or not referential) and bears on all verbs that participate in an impersonal argument structure. (We assume, following Miller and Sag (1997) and Ginzburg and Sag (2001) that *pro* subjects are modeled through a particular kind of non-canonical *synsem*, as indicated in (6) by the type *pro-ss* of the sole *synsem* member of the SUBJECT list.)

$$(6) \quad \textit{impersonal-verb} \Rightarrow \left[\text{SUBJ} \left\langle \left[\begin{array}{l} \textit{pro-ss} \\ \text{CONTENT } \textit{expl} \end{array} \right] \right\rangle \right]$$

Constraint (7) models generalizations a'. and b. It requires of a structure that is an infinitival *head-subject-phrase* that its subject be dative. The constructional nature of this constraint (i.e., the fact that it pertains to a category of phrase-structural configurations) properly restricts generalization a. to *expressed* subjects, as in our revised generalization a'., at least under the typical HPSG hypothesis that phrase-structurally projected subject requirements cannot be silent (with the possible exception of traces of extracted constituents).

$$(7) \quad \left[\begin{array}{l} \textit{hd-subj-ph} \\ \text{HEAD} \quad \textit{infin} \end{array} \right] \Rightarrow \left[\text{DTRS} \left\langle \left[\text{CASE } \textit{dat}, \dots \right] \right\rangle \right]$$

In other words, constraint (7) trades Perlmutter and Moore's descriptive observation based on a pre-theoretical notion of clause for a constraint that bears only on phrases composed of an (expressed) subject and a phrasal head.

Constraint (8) models the Russian-specific morphological generalization d. by requiring semantically expletive *synsems* to bear nominative case.

$$(8) \quad \left[\text{CONTENT } \textit{expl} \right] \Rightarrow \left[\text{CASE } \textit{nom} \right]$$

Additionally, the contrast between the simplified entry for *čtoby* 'in order to' in (9) and the entry for raising verbs such as *perestavat'* 'stop' given in (10) embodies our hypothesis e. The entry in (9) subcategorizes for an infinitival clause (an infinitival verbal projection whose subject and complements requirements are saturated), whereas the entry in (10) subcategorizes for an infinitival VP (an infinitival verbal projection whose complements requirements are saturated, but whose subject requirement is not).

$$(9) \quad \left[\begin{array}{l} \textit{čtoby} \\ \text{ARG-ST} \left\langle \left[\begin{array}{l} \text{SUBJ} \langle \rangle \\ \text{COMPS} \langle \rangle \\ \text{HEAD} \left[\text{VFORM } \textit{inf} \right] \end{array} \right] \right\rangle \end{array} \right]$$

²To avoid clutter, the representation of our constraints does not respect HPSG's feature geometry. Nothing substantive hinges on this strictly editorial simplification.

$$(10) \left[\begin{array}{l} \text{perestavat'} \\ \text{ARG-ST} \left\langle \begin{array}{l} \boxed{1}, \left[\begin{array}{l} \text{SUBJECT} \left\langle \boxed{1} \left[\begin{array}{l} \text{HEAD} \textit{noun} \end{array} \right] \right\rangle \\ \text{HEAD} \left[\begin{array}{l} \text{VFORM} \textit{inf} \end{array} \right] \end{array} \right\rangle \end{array} \right\rangle \end{array} \right]$$

Together, these constraints provide for an easy explanation of the contrast in grammaticality of sentence (4) and sentences (3-b) or (11) (below). Sentence (4) is grammatical because the complement of *načalo* ‘begin’ is a VP whose (unexpressed) expletive subject can bear the nominative case of the raising pivot, since the need for a dative subject is only relevant to phrases of type *head-subject-phrase*, i.e. of phrases with a saturated subject requirement. Sentences (3-b) and (11), on the other hand, are ungrammatical because *čtoby* subcategorizes for a clause, i.e. a verbal projection in which the verb’s subject requirement *must be* expressed and no subject is expressed.³

- (11) **čtoby* Boris_{ACC} *tošnit'* zimoj
in.order Boris-ACC nauseate-INF winter
‘in order for Boris to feel nauseous in the winter’

3 Conclusions and Implications

The following table compares the statements needed to model the Russian data under Perlmutter and Moore’s and our analyses.

Perlmutter and Moore	Koenig and Davis
All subject (expressed or unexpressed) of infinitival verbs are dative	Only expressed subjects of infinitival verbs are dative
PRO subjects can sometimes bear the case of their controller	N/A
<i>pro</i> cannot be dative	N/A

Our answer to Perlmutter and Moore’s challenge to the HPSG analysis of raising relies on two important hypotheses about natural languages:

1. Verbal complements may be VPs or clauses;
2. Natural languages include language-specific constraints on phrase-structural configurations (e.g., in Russian, the subjects of infinitival *head-subject-phrases* are dative).

³The verb *tošnit'* in (11) is exceptional in that the experiencer, here *Boris*, must appear in accusative case; its subject is an (unexpressed) impersonal element. But since the complement clause is infinitive, it requires a dative, and hence expressed, subject.

Does the analysis we propose compare favorably to Perlmutter and Moore's? Since the two analyses are equivalent descriptively, a definitive answer to this question is unlikely. We merely make two remarks here. First, our analysis account for why control and raising structures appear to be exceptions to Perlmutter and Moore's generalization a. In our analysis, they are not exceptions, because this generalization only pertains to subject-predicate constructs, while raising and control verbal complements are VPs, not subject-predicate constructs. Of course, Perlmutter and Moore may be able to explain these exceptions (in terms, for example, of a reduced set of functional projections for raising and control verbal complements), but it remains true that only generalization a' receives direct observable evidence.

Second, crosslinguistic evidence may favor the kind of analysis we are proposing. Russian makes a comparison based on descriptive adequacy between the two analyses difficult, since expletive subjects, which must be both nominative and unexpressed, are ruled out in infinitival clause environments. French, however, provides more fertile grounds for such a comparison. French expletives must be both nominative and expressed. Consider (12) (Perlmutter and Moore's examples (79) and (80)):

- (12) a. Il pleut.
 *(EXPL.NOM) rain.3SG-PRST.
 It rains.
- b. J' entends pleuvoir
 I hear.3SG-PRST rain.INF
 I hear it rain.
- c. *Je l' entends pleuvoir
 I EXPL.ACC hear.3SG-PRST rain.INF
 I hear it rain.

Sentence (12-a) shows that French expletives must be expressed. The contrast between sentences (12-b) and (12-c) shows that there are no accusative expletives in French. To generalize their analysis to French, Perlmutter and Moore must posit both that French nominative expletives must be *expressed* and that French accusative expletives must be *silent*. Such a proposal is suboptimal on two counts. First, French is not a *pro*-drop language; positing silent expletives in infinitival clauses is therefore not otherwise motivated. Second, Perlmutter and Moore's proposal does not account for the fact that an expletive is unexpressed in only those very contexts in which an *expressed* expletive is impossible. Additional data further question such an analysis. Consider the following examples.

- (13) a. Que vous partiez est nécessaire.
 that you leave.SUBJ is necessary
 'For you to leave is necessary.' (sic)

- b. Il est nécessaire que vous partiez.
EXPL is necessary that you leave.SUBJ
'It is necessary for you to leave.'
- (14) a. *Que vous partiez est grand temps.
that you leave.SUBJ is big time
'For you to leave is high time.' (sic)
- b. Il est grand temps que vous partiez.
EXPL is big time that you leave.SUBJ
'It is high time for you to leave.'

Sentences (13) show that the predicate adjective *nécessaire* 'necessary' allows its sentential complement to both be extraposed and occur in subject position. Sentences (14) show that, in contrast, the predicate nominal *grand temps* 'high time' requires its sentential complement to be extraposed. Compare now sentences (15) and (16).

- (15) George trouve nécessaire que vous partiez.
George finds necessary that you leave.SUBJ
'George finds it necessary for you to leave.'
- (16) *George trouve grand temps que vous partiez.
George finds big time that you leave.SUBJ
'George finds it high time for you to leave.'

An AP whose head is *nécessaire* can be embedded under the verb *trouver* 'to find', but not an AP whose head is the expression *grand temps*. One possible explanation for this contrast builds on the hypothesis that the direct object of the verb *trouver* must be "referential" (see Borkin (1984/1974) for some suggestions in that direction for the English verb *find* and Ducrot (1980) for some suggestions that *might* be similarly interpreted for the French verb *trouver*). Since *nécessaire* allows its sentential complement to be its subject, it may serve as the direct object of *trouver*; since the sentential complement of *trouver* must be extraposed, its expletive subject would have to become the object of *trouver*, violating the constraint that it be "referential". More solid evidence that the direct object of *trouver* is "referential" is required for this type of evidence to definitively rule out Perlmutter and Moore's analysis of French expletives, but the contrast between *nécessaire* and *grand temps* suggests that it may be descriptively on the wrong track. Our constructional analysis of the Russian data fares better when applied to French. We need only stipulate that French accusative pronouns are always referential (in HPSG's technical sense). In other words, the reason the subject expletives of the infinitival complements of raising verbs can be unexpressed is that these complements are Vs or VPs,

not clauses or subject-predicate constructs. There is no need to say that French is a *necessary pro-drop* language precisely when the subject is an expletive and in embedded infinitival clauses since in those contexts, in our analysis, there are no clauses, just Vs or VPs.

Let us now conclude on a more architectural note. As we mentioned earlier, the first hypothesis mentioned at the beginning of this section is part and parcel of constraint-based lexicalist approaches to grammar since the early 80's. The second hypothesis is part of a more innovative research program that started with Fillmore and Kay's work on Construction Grammar (see Fillmore *et al.* (1988)) and assumes that language-specific syntactic or semantic constraints can be attached to phrase-structural schemata. The "constructional stance" required to model the Russian data is rather minimal compared to the detailed network of constructions discussed in Sag (1997), Fillmore (1999), or Ginzburg and Sag (2001): the ability to refer to classes of phrase-structural configurations in the statement of language-specific constraints. But even this minimal stance has its advantages for constraint-based lexicalist approaches. We can preserve the advantages of HPSG's raising theory (over, say, LFG's) for Icelandic without having it falter on Russian.

The standard HPSG treatment of raising and the alternative set out here thus illustrate two contrasting analytical possibilities within HPSG, one capturing syntactic behavior through lexical requirements and the other, constructional one employing schemata, which is accordingly less "lexical". A natural question at this point is whether there are other phenomena that appear equally amenable to either type of analysis, but which, on more detailed examination, exhibit properties that favor one type of account over the other. While we have no specific examples to present here, we surmise that some agreement constraints might best be modeled through constraints on particular phrase-structural constructs, rather than lexical constraints between heads and their non-head dependents (complements, subjects, or modifiers), as in Pollard and Sag (1994). This might be particularly *à propos* in cases where the dependent's agreement properties cannot readily be determined by lexical features of a head, either because a (unique) head is not identifiable, or because its features are overridden by other considerations.

References

- BORKIN, ANN. 1984/1974. *Problems in Form and Function*. Norwood, NJ: Ablex.
- BRESNAN, JOAN, and RONALD KAPLAN. 1982. *The Mental Representation of Grammatical Relations*. Cambridge, MA: MIT Press.
- CHOMSKY, NOAM. 1981. *Lectures on Government and Binding*. Dordrecht: Foris.
- COMRIE, BERNARD. 1974. The second dative: A transformational approach. *Slavic transformational syntax*, ed. by Richard Brecht and Catherine Chvany,

- Michigan Slavic Materials No 10, 123–150. University of Michigan, Ann Arbor: .
- DUCROT, OSWALD. 1980. *Les mots du discours*. Paris: Les ditions de minuit.
- FILLMORE, CHARLES. 1999. Inversion and constructional inheritance. *Lexical and constructional aspects of linguistic explanation*, ed. by Gert Webelhuth, Jean-Pierre Koenig, and Andreas Kathol, 113–128. Stanford: CSLI Publications.
- , PAUL KAY, and CATHERINE O’CONNOR. 1988. Regularity and idiomatity in grammatical constructions: the case of *Let alone*. *Language* 64.501–538.
- FRANKS, STEVEN. 1995. *Parameters of Slavic Morphosyntax*. Oxford: Oxford University Press.
- GAZDAR, GERALD, EWAN KLEIN, GEOFFREY PULLUM, and IVAN SAG. 1985. *Generalized Phrase Structure Grammar*. Cambridge, MA: Harvard University Press.
- GINZBURG, JONATHAN, and IVAN SAG. 2001. *Interrogative Investigations: The Form, Meaning, and Use of English Interrogatives*. Stanford: CSLI Publications.
- JACOBSON, PAULINE. 1990. Raising as function composition. *Linguistics and Philosophy* 423–475.
- KATHOL, ANDREAS. 2001. Positional effects in a monostratal grammar of german. *Journal of Linguistics* 37.35–66.
- MILLER, PHILIP, and IVAN SAG. 1997. French clitic movement without clitics or movement. *Natural Language and Linguistic Theory* 15.573–639.
- MOORE, JOHN, and DAVID PERLMUTTER. 2000. What does it take to be a dative subject? *Natural Language and Linguistic Theory* 18.373–416.
- PERLMUTTER, DAVID, and JOHN MOORE. 2002. Language-internal explanation: the distribution of Russian impersonals. *Language* 78.619–650.
- POLLARD, CARL, and IVAN SAG. 1994. *Head-Driven Phrase-Structure Grammar*. Chicago: Chicago University Press.
- SAG, IVAN. 1997. English relative clauses. *Journal of Linguistics* 33.431–483.
- SAG, IVAN A., LAURI KARTTUNEN, and JEFFREY GOLDBERG. 1992. A lexical analysis of Icelandic case. *Lexical matters*, ed. by Ivan A. Sag and Anna Szabolcsi, 301–318. Stanford: CSLI Publications.

Between shifts and alternations: Ditransitive constructions

Valia Kordoni 

Saarland University

Proceedings of the 11th International Conference on
Head-Driven Phrase Structure Grammar

Center for Computational Linguistics, Katholieke Universiteit Leuven

Stefan Müller (Editor)

2004

Stanford, CA: CSLI Publications

pages 151–167

Kordoni, Valia. 2004. Between shifts and alternations: Ditransitive constructions. In Stefan Müller (ed.), *Proceedings of the 11th International Conference on Head-Driven Phrase Structure Grammar*, Center for Computational Linguistics, Katholieke Universiteit Leuven, 151–167. Stanford, CA: CSLI Publications. DOI: 10.21248/hpsg.2004.9. 

Abstract

In this paper I present two classes of double object constructions in Modern Greek, i.e., the genitive, as well as the double accusative, ditransitive constructions. I show that these two classes differ from one another in that not both of them permit derivational processes such as the formation of adjectival passives. I also look at the case properties associated with the verbs which head Modern Greek genitive and double accusative ditransitive constructions. Finally, the analysis I propose for these constructions in Modern Greek are formalized using the Minimal Recursion Semantics (MRS) framework of Copestake et al. (2001) and Copestake et al. (2003).

1 Introduction

In this paper, I propose a robust deep analysis of Modern Greek structures of the following form:

- (1) O Petros edose to vivlio s-tin Maria.
the Peter.Nom give.3SG.PAST the book.Acc to-the Maria.Acc
“Peter gave the book to Mary”.
- (2) O Petros edose tis Marias to vivlio.
the Peter.Nom give.3SG.PAST the Maria.Gen the book.Acc
“Peter gave Mary the book”.

The rest of this paper is organised as follows. In the next section (Section (2)) I give an overview of the relevant data in Modern Greek. In Section (3) I deal with the case properties of Modern Greek genitive and double accusative ditransitive constructions. In Section (4) I present the robust deep analysis of ditransitives that I argue for in this paper, and I discuss this analysis in comparison to relevant influential crosslinguistic studies of similar phenomena. Finally, in Section (5) I am highlighting some of the advantages that the analysis presented in Section (4) brings to the task of development of broad coverage grammars of natural language.

2 The Data

Modern Greek distinguishes two types of ditransitive constructions, the genitive ditransitive construction (see Section (2.1)) and the double accusative ditransitive construction (see Section (2.2)).

2.1 The Genitive Ditransitive Construction

In Modern Greek the goal in most ditransitives surfaces as a PP (see example (3)), or as an NP with morphological genitive case (see example (4)):

- (3) O Petros estile ta hrimata s-tin Maria.
the Peter.Nom send.3SG.PAST the money.Acc.PL to-the Maria.Acc
“Peter sent the money to Mary”.
- (4) O Petros estile tis Marias ta hrimata.
the Peter.Nom send.3SG.PAST the Maria.Gen the money.Acc.PL
“Peter sent Mary the money”.

Anagnostopoulou (1999) argues that the Modern Greek genitive ditransitive construction is a double object construction.

2.2 The Double Accusative Ditransitive Construction

With a limited set of verbs both the indirect object and the direct object may surface with morphological *accusative* case used without a preposition.¹ These verbs include the predicates *serviro* (serve), *plirano* (pay), *didasko* (teach):

- (5) O servitoros servire ton pelati enan kafe.
the waiter.Nom serve.3SG.PAST the customer.Acc a coffee.Acc
“The waiter served the customer a coffee”.
- (6) O servitoros servire enan kafe s-ton pelati.
the waiter.Nom serve.3SG.PAST a coffee.Acc to-the customer.Acc
“The waiter served a coffee to the customer”.
- (7) Plirosa ton spitonikokiri ta nikia pu tu
pay.1SG.PAST the landlord.Acc the rent.Acc.PL that him.CI.Gen
ofila.
owe.1SG.PAST
“I paid the landlord the rents that I owed him”.
- (8) Plirosa s-ton spitonikokiri ta nikia pu tu
pay.1SG.PAST to-the landlord.Acc the rent.Acc.PL that him.CI.Gen
ofila.
owe.1SG.PAST
“I paid to the landlord the rents that I owed him”.
- (9) O kathigitis didakse tus fitites tin
the professor.Nom teach.3SG.PAST the student.Acc.PL the
ili ton mathimatikon profata.
course-material.Acc the maths.Gen.PL recently
“The professor taught the students the course material for the maths recently”.

¹These verbs may also form a double object construction in which the goal bears genitive case morphology. In this case, they behave syntactically similarly to verbs forming the genitive ditransitive construction presented in Section (2.1).

- (10) O kathigitis didakse tin ili ton
 the professor.Nom teach.3SG.PAST the course-material.Acc the
 mathimatikon s-tus fitites profata.
 maths.Gen.PL to-the student.Acc.PL recently
 “The professor taught the course material for the maths to the students
 recently”.

2.3 Evidence for two structures

Adjectival passives with goal externalization are not possible with the verbs forming the genitive ditransitive construction (see Section (2.1)):

- (11) O Petros estile to paketo s-tin mitera
 the Peter.Nom send.3SG.PAST the packet.Acc to-the mother.Acc
 tu polu profata.
 his.Cl.Gen very recently
 “Peter sent the packet to his mother very recently”.
- (12) O Petros estile tis miteras tu to paketo
 the Peter.Nom send.3SG.PAST the mother.Gen his.Cl.Gen the packet.Acc
 polu profata.
 very recently
 “Peter sent his mother the packet very recently”.
- (13) Ena profata stalmeno paketo. /* Mia profata stalmeni mitera.
 a recently sent packet /* a recently sent mother
 “A recently sent packet”. /* “A recently sent mother”.

We take it that the ban on goal externalization could/should be reduced to the genitive case morphology of the goal (see Kratzer (1993)).

In contrast, adjectival passives with goal externalization are possible with the verbs forming the double accusative ditransitive construction (the following example reads in relation to examples (9) and (10) of Section (2.2)):

- (14) I profata didagmeni ili ton mathimatikon./I profata
 the recently taught course-material the maths.Gen.PL/the recently
 didagmeni fitites.
 taught students
 “The recently taught course material for the maths”./ “The recently taught
 students”.

Moreover, in Modern Greek the two verb classes differ with respect to nominalization. Nominalizations where the goal surfaces as the non-prepositional complement of the noun are not possible with the verbal predicates participating in the genitive ditransitive construction (examples (15)-(17)), while they are possible

with the verbal predicates participating in the double accusative ditransitive construction (example (18) in relation to examples (9) and (10) of Section (2.2)):

- (15) O Petros nikiase to spiti s-ton fititi.
 the Peter.Nom rent.3SG.PAST the house.Acc to-the student.Acc
 “Peter rent the house to the student”.
- (16) O Petros nikiase tu fititi to spiti.
 the Peter.Nom rent.3SG.PAST the student.Gen the house.Acc
 “Peter rent the student the house”.
- (17) To nikiasma tu spitiu. /* To nikiasma tu fititi.
 the rental the house.Gen /* the rental the student.Gen
 “The rental of the house”. /* “The rental of the student”.
- (18) I didaskalia tis ilis ton mathimatikon. / I
 the teaching the course-material.Gen.SG the maths.Gen.PL / the
 didaskalia ton fititon.
 teaching the students.Gen.PL
 “The teaching of the course material for the maths”. / “The teaching of the students”.

3 Case Assignment in Modern Greek Genitive and Double Accusative Ditransitive Constructions

In genitive ditransitive construction in Modern Greek, like the ones presented in Section (2.1) in the previous (see example (4)), we observe that clitic doubling is possible with both the genitive goal, as well as the accusative theme:

- (19) (Tis) (ta) estile o Petros tis
 cl.Gen.Fem.SG cl.Acc.Neut.PL send.3SG.PAST the Peter.Nom.SG the
 Marias ta hrimata.
 Maria.Gen.Fem.SG the money.Acc.Neut.PL
 “Peter sent Mary the money”.

Clitic doubling in (19) above shows that both the genitive goal and the accusative theme bear structural case.

Moreover, passivization of the theme argument of Modern Greek genitive ditransitive constructions is also possible, provided that the goal argument of these constructions is clitic doubled:

- (20) Ta hrimata *(tis) stalthikan tis
 the money.Nom.PL cl.Gen.Fem.SG send.3PL.PAST.PASS the
 Marias apo ton Petro.
 Maria.Gen.Fem.SG by the Petro
 “The money was sent to Mary by Peter”.

The fact that the theme argument of the genitive ditransitive constructions in Modern Greek may undergo passivization when the goal argument is clitic doubled shows that it bears structural accusative case.

Turning to double accusative ditransitive constructions in Modern Greek, like the ones described in Section (2.2) above, Anagnostopoulou (1999) has observed that the goal exhibits all the properties of a structural object. That is, it bears a morphological accusative case, it can be doubled by a clitic (see example (21) below) and it may undergo passivization (see example (22) below):

- (21) (Tus) didakse tus fitites ta mathimatika.
 cl.Acc.PL teach.3SG.PAST the students.Acc.PL the maths.Acc.PL
 “He taught the students the maths”.
- (22) I fitites didahthikan ta mathimatika.
 the students.Nom.PL. teach.3PL.PAST.PASS the maths.Acc.PL
 “The students were taught the maths”.

On the contrary, as Anagnostopoulou (1999) underlines, the same does not hold for the theme argument of these constructions. That is, clitic doubling of the theme argument renders the Modern Greek double accusative ditransitive constructions ungrammatical:

- (23) *Ta didakse tus fitites ta
 cl.Acc.Neuter.PL teach.3SG.PAST the students.Acc.Masc.PL the
 mathimatika.
 maths.Acc.Neuter.PL
 “He taught the students the maths”.

Moreover, Anagnostopoulou (1999) also points out that passivization of the theme across a goal in the double accusative ditransitive constructions in Modern Greek is not possible, even when the goal is clitic doubled:

- (24) *Ta mathimatika tus didahthikan tus
 the maths.Acc.Neuter.PL cl.Acc.Masc.PL teach.3PL.PAST.PASS the
 fitites.
 students.Acc.Masc.PL
 “The maths were taught to the students”.
- (25) *Ta mathimatika tus didahthikan.
 the maths.Acc.Neuter.PL cl.Acc.Masc.PL teach.3PL.PAST.PASS
 “The maths were taught to them”.

It would have been, indeed, very simple to attribute the exceptional behaviour of the theme argument of the Modern Greek double accusative ditransitive constructions to the fact that it might bear an inherent accusative case. We are afraid,

though, that this would have been too simplistic an analysis, since the theme argument of these constructions in Modern Greek exhibits all the properties of a structural object, when the accusative goal undergoes passivization, for instance:

- (26) I fitites ta didahthikan ta mathimatika
 the students.Nom.PL cl.Acc.PL teach.3PL.PAST.PASS the maths.Acc.PL
 apo ton kathigiti.
 by the professor
 ‘‘The students were taught the maths by the professor’’.

That is, as is shown in example (26) above and as Anagnostopoulou (1999) also notes, the theme argument can be clitic doubled in the passive form of Modern Greek double accusative ditransitive constructions. This implies that this argument does not bear the same kind of case in active and passive sentences. This in turn argues against the assumption that the theme has inherent case, since a defining property of inherent case is that it never enters into case alternations.

Passivization of the theme argument across the goal in Modern Greek double accusative ditransitive constructions leads to very strong ungrammaticality (see examples (24) and (25) above), unlike passivization of the theme argument in the presence of an undoubled genitive goal (see example (20) above), which only gives rise to mildly ungrammatical sentences.

Thus, Anagnostopoulou (1999) concludes that while passivization of themes across goals (direct passives) is not possible either in Modern Greek genitive, or in Modern Greek double accusative ditransitive constructions, the cause of the violation is different. She claims that in Modern Greek genitive ditransitive constructions the problem is posed by Locality, while in Modern Greek double accusative ditransitive constructions the problem seems to be posed by the fact that the theme argument bears an inherent accusative case.

Anagnostopoulou (1999) mentions that a similar behaviour is also found in English. That is, sentences involving passivization of themes in the presence of goals are judged as ‘‘quite marginal’’ (cf., Larson (1988)):

- (27) ?*A letter was sent Mary.

According to Larson (1988), passive sentences like the one in (27) are often judged to be better if the goal is an unstressed pronoun:

- (28) A letter was given'im/*HIM by Mary.

Thus, indirect object weak pronouns in English passives have an effect comparable to the effect of ‘‘dative’’ clitics in Greek passives.

3.1 Theme incorporation

In double accusative ditransitive constructions in Modern Greek the goal argument may surface as a sole complement:

- (29) Didasko tus fitites.
teach.1SG the students.Acc.PL
“I teach the students.”
- (30) Serviro ton pelati.
serve.1SG the customer.Acc.SG
“I serve the customer”.
- (31) Plirono ton ipalilo.
pay.1SG the employee.Acc.SG
“I pay the employee”.

Moreover, as also shown by Anagnostopoulou (1999), there are cases of overt noun incorporation of the theme in Modern Greek where the goal surfaces as an accusative object, and not as a PP (see example (33)), or a genitive NP (see example (35); the examples are from Anagnostopoulou (1999)):

- (32) Dino trofima stus aporus.
give.1SG food.Acc.PL to-the poor
“I give food to the poor”.
- (33) Trofodoto tus aporus / *stus aporus.
food-give.1SG the poor.Acc.PL / *to-the poor
“I give food to the poor.”
- (34) Dino tis Marias hrimata.
give.1SG the Maria.Gen.SG money.Acc.PL
“I give Mary money”.
- (35) Hrimatodoto tin Maria / *tis Marias.
money-give.1SG the Maria.Acc.SG / *the Maria.Gen.SG
“I give money to Mary”.

Anagnostopoulou (1999) concludes that such examples constitute evidence that theme incorporation takes place in the double accusative ditransitive constructions, but not in the PP, or the genitive, ditransitive constructions in Modern Greek.

4 Between shifts and alternations

4.1 Overview

As Levin and Rappaport Hovav (2001) have pointed out, the terms *dative shift* and *dative alternation* reflect two major classes of analyses of the variable expression of arguments characteristic of the verb *give* (in English) and semantically related verbs.

The *dative shift* approach, as Levin and Rappaport Hovav (2001) have shown, is a derivational analysis that assumes that these verbs have a single meaning, giving rise to two derivationally related syntactic structures. The two variants never

involve any difference in truth-conditional meaning. This analysis tends to be syntactically rather than semantically motivated.

There are *dative shift* analyses in the literature, like, for instance, the ones proposed by Baker (1988), den Dikken (1995), Larson (1988), among others, according to which the *to*-variant is considered to be the basic. Other *dative shift* approaches prefer the double object variant as the basic one (see, for instance, Dryer (1986)).

The *dative alternation* approach, as Levin and Rappaport Hovav (2001) have pointed out, is a non-derivational analysis that assumes that *give* and verbs semantically related to it have two distinct meanings, each giving rise to its own syntactic realization of arguments (cf., among others, Arad (1998), Green (1974), Hale and Keyser (1996), Harley (1997), Krifka (1999), Oehrle (1975), Pinker (1989)).

The alternate argument realizations arise because distinct arguments satisfy the semantic conditions for mapping to *direct object* in each alternant. This analysis tends to be motivated by lexical semantic considerations (see, for instance, (37) in Section (4.2) below):

- (36) a. ‘x cause y to have z’, giving rise to the double object alternant *give Peter a book*
b. ‘x cause z to be at y’, giving rise to the *to*-variant *give a book to Peter*

Recently, a constructional version of this approach has also emerged (e.g., Goldberg (1995)). According to this constructional analysis, the verb *give* and its semantically related verbs are monosemous, but their core meaning is compatible with two syntactico-semantic constructions. Since constructions are defined as form and meaning pairs, each verb-syntactic frame is associated with a distinct meaning. Thus, this can also be viewed as a two-meaning approach.

4.2 The Analysis

For Modern Greek genitive ditransitive constructions (see Section (2.1)) I argue for an account which shares with the “dative shift” approaches the idea that there is a single verb meaning involved, and with the “dative alternation” approaches the idea that variants are nonderivationally related (see Butt et al. (1997), Wechsler (1995), among others, for similar approaches in LFG and HPSG, respectively, to English ditransitives).

The starting point of the analysis for predicates heading Modern Greek genitive ditransitive constructions is that they are not polysemous and, more generally, the genitive ditransitive alternation does not involve two distinct meanings for each individual ditransitive predicate.

In the spirit of Levin and Rappaport Hovav (2001), I propose that the key idea is that the genitive ditransitive alternation in Modern Greek is not about alternate objects, like for instance, the locative alternation in Modern Greek, but about alternate expressions of recipients (i.e., animate goals).

That is, recipients in Modern Greek genitive ditransitive constructions may be realized in two ways as they are open to two semantic characterizations (see also Goldsmith (1980) for English): (i) a type of possessor, (ii) a type of goal, as the Localist Hypothesis predicts (cf., also Gruber (1965), Jackendoff (1972)).²

The consequence of the availability of two semantic characterizations for recipients in the case of Modern Greek genitive ditransitive constructions (i.e., possessors and goals) is that recipients have also two potential modes of syntactic instantiation: (i) a genitive case-marked NP (see example (4) in Section (2.1) and example (12) in Section (2.3)), (ii) a PP (*s-tin* (to)-phrase in example (3) in Section (2.1) and example (11) in Section (2.3)).

For Modern Greek double accusative ditransitive constructions (see Section (2.2)) I propose an analysis which shares with the “dative alternation” approaches the idea that variants are nonderivationally related.

I also propose, though, that unlike the genitive ditransitive constructions in Modern Greek as shown in Section (2.1) the double accusative ditransitive construction is about alternate objects, like for instance, the locative alternation in Modern Greek. This proposal is strongly supported by the evidence from adjectival passives and nominalizations presented in Section (2.3) in relation to Modern Greek double accusative ditransitive constructions, which shows that with predicates heading double accusative ditransitives either the *theme* or the *recipient* argument exhibits “object” properties, depending on which is (the primary) object. Such an analysis tends to be accompanied by different lexical semantic entailments in relation to the two variants:³

- (37) From Arad (1998)
- a. *to*-VARIANT: x cause [y to come to be at (possession) z]
 - b. DOUBLE OBJECT VARIANT: x cause [z to come to be in STATE (of possession)] by means of [x cause [y to come to be at (poss) z]]

4.3 The Formalization

The analyses sketched above for the genitive and the double accusative ditransitive constructions in Modern Greek are formalized here using the Minimal Recursion Semantics (MRS) framework of Copestake et al. (2001) and Copestake et al. (2003).

In brief, Minimal Recursion Semantics is a framework for computational semantics, in which the meaning of expressions is represented as a flat bag of Elementary Predications (or EPs) encoded as values of a RELS attribute. The denotation of this bag is equivalent to the logical conjunction of its members. Scope

²In support of point (ii), and as far as English is concerned, Pesetsky (1995, p. 141) points out that “the semantics of *to*-objects seems to be a superset of the semantics of directly selected goals (i.e., recipients)”.

³As we have also mentioned in (4.1) above, recently a constructional version of such an approach has also emerged (see Goldberg (1995)).

relations between EPs are represented as explicit relations among EPs. Such scope relations can also be underspecified. The assumption of current MRS is that each lexical item (other than those with empty EP bags) has a single distinguished main EP, which is referred to as the *KEY* EP. All other EPs either share a label with the *KEY* EP or are equal to some scopal argument of the *KEY* EP.

For situation-denoting EPs, which are also most interesting for our purposes here, the following generalizations hold: (i) EPs do not encode recursively embedded state-of-affairs (SOAs); (ii) EPs can have one, two, or three arguments. Finally, as far as direct arguments are concerned, these are predicted to link off the value of the *KEY* attribute.

4.3.1 Modern Greek Genitive Ditransitive Constructions: at the Syntax-Semantics Interface

- (38) CONTENT of Modern Greek Genitive Ditransitive Constructions (example (4))

$$\left[\begin{array}{l} \text{KEY } \boxed{5} \left[\begin{array}{l} \textit{stelno-change-of-possession-rel} \\ \text{ACT } \boxed{1} (o \textit{ Petros}) \\ \text{POSSESSOR/RECIPIENT } \boxed{4} (\textit{tis Marias}) \\ \text{UND/THEME } \boxed{3} (\textit{ta hrimata}) \end{array} \right] \\ \text{RELS } \langle \boxed{5}, \left[\begin{array}{l} \textit{stelno-change-of-location-rel} \\ \text{ACT } \boxed{1} (o \textit{ Petros}) \\ \text{FIGURE } \boxed{3} (\textit{ta hrimata}) \\ \text{GROUND } \boxed{4} (\textit{Marias}) \end{array} \right] \rangle \end{array} \right]$$

- (39) CONTENT of Modern Greek PP Ditransitive Constructions (example (3))⁴

$$\left[\begin{array}{l} \text{KEY } \boxed{5} \left[\begin{array}{l} \textit{stelno-change-of-location-rel} \\ \text{ACT } \boxed{1} (o \textit{ Petros}) \\ \text{UND/FIGURE } \boxed{3} (\textit{ta hrimata}) \\ \text{GOAL/RECIPIENT (GROUND) } \boxed{4} (\textit{stin Maria}) \end{array} \right] \\ \text{RELS } \langle \boxed{5} \rangle \end{array} \right]$$

⁴UND/FIGURE is used in order to denote an argument which is an UND(ergoer) and at the same time a moving entity (FIG(ure)); see also Davis (1996).

4.3.2 Modern Greek Double Accusative Ditransitive Constructions: at the Syntax-Semantics Interface

- (40) CONTENT of Modern Greek Double Accusative Ditransitive Constructions (example (9); close to the entailments shown in (37))

$$\left[\begin{array}{l} \text{KEY } \boxed{3} \left[\begin{array}{l} \textit{didasko-change-of-possession-rel} \\ \text{ACT } \boxed{1} (o \textit{kathigitis}) \\ \text{UND/POSSESSOR/RECIPIENT } \boxed{2} (\textit{tus fitites}) \\ \text{FIGURE/THEME } \boxed{4} (\textit{tin ili}) \end{array} \right] \\ \text{RELS } \langle \boxed{3}, \left[\begin{array}{l} \textit{didasko-change-of-location-rel} \\ \text{ACT } \boxed{1} (o \textit{kathigitis}) \\ \text{FIGURE } \boxed{4} (\textit{ili}) \\ \text{GROUND } \boxed{2} (\textit{fitites}) \end{array} \right] \rangle \end{array} \right]$$

- (41) CONTENT of Modern Greek PP Ditransitive Constructions (example (10); close to the entailments shown in (37))

$$\left[\begin{array}{l} \text{KEY } \boxed{3} \left[\begin{array}{l} \textit{didasko-change-of-location-rel} \\ \text{ACT } \boxed{1} (o \textit{kathigitis}) \\ \text{UND/FIGURE } \boxed{2} (\textit{tin ili}) \\ \text{GOAL/RECIPIENT (GROUND) } \boxed{4} (\textit{stus fitites}) \end{array} \right] \\ \text{RELS } \langle \boxed{3} \rangle \end{array} \right]$$

4.3.3 Discussion: Evidence for the first object as possessor

As is also clearly shown in the HPSG formalization of Modern Greek genitive and double accusative ditransitive constructions presented in (38)-(41) in Sections (4.3.1) and (4.3.2) above, recipients are open to two syntactico-semantic characterizations, i.e., that of the possessor and that of the goal.

Consequently, recipients have two expressions:

- they may be realized as goals are encoded (i.e., the object of *ston* in the PP variant; see (39) and (41) above), or
- they may be realized as possessors are encoded (i.e., the first object in the ditransitive constructions in Modern Greek; see (38) and (40) above).

From a crosslinguistic point of view, according to Levin and Rappaport Hovav (2001), many languages which lack double objects still have a core (i.e., non-adjunct) grammatical relation, distinct from subject and object, used to express

possessors. Specifically, as Levin and Rappaport Hovav (2001) mention, many languages have a dative case and use the dative (case marked) NP as the basic expression of possessors, including recipients of ditransitive constructions.

There are, then, according to Levin and Rappaport Hovav (2001), two dedicated modes of expressing possessors:

- the first object in a double object frame, and
- a dative NP.

This is exactly what we have observed in the behaviour of Modern Greek genitive and double accusative ditransitive constructions (see, for instance, (38)-(41) in Sections (4.3.1) and (4.3.2) above). Only instead of a dative NP, in Modern Greek we observe a genitive NP.

Siewierska (1998) finds that no language which has a “true” dative case (i.e., use of a marker which is distinct from allative or locative markers) has a double object construction or a construction in which the recipient and patient receive the same encoding.

This observation suggests that crosslinguistically dative NPs and first objects, and thus the dative frame and double object frame, are in complementary distribution. Given this, they might be considered two sides of the same coin.

This also holds for Modern Greek, as we have already seen in the previous (see (38) and (40) in the previous). One has to keep in mind, though, that in the case of the Modern Greek double accusative ditransitive verbs *didasko* (teach), *serviro* (serve), and *plirono* (pay) the recipient/possessor and the patient/undergoer bear the same morphological case.

In the light, then, of Modern Greek double accusative ditransitive constructions the generalization of Siewierska (1998) might seem to be rather unexpected, since the “dative”/ditransitive alternation is also shown to be about the semantic determinants of “objecthood”.

Crosslinguistically, thus, and in the light of the Modern Greek data presented in the previous, four frames are associated with the expression of recipients:

- Allative frame (recipient as goal): in this frame the theme is syntactically realized as object, the recipient (allative) as locative NP/PP.
- Double object frame (recipient as possessor): in this frame the theme is syntactically realized as secondary object, while the recipient is syntactically realized as first object.
- Dative frame (recipient as possessor): in this frame the theme is syntactically realized as object, while the recipient is syntactically realized as a dative NP.
- Genitive frame (recipient as possessor): in this frame the theme is syntactically realized as object, while the recipient is syntactically realized as a genitive NP.

The consequence of all this, as Levin and Rappaport Hovav (2001) underline, is that in English, for instance, *to* is not a dative preposition, as some suggest, but an allative preposition, and the *to*-variant is, thus, an instance of the allative frame. As Siewierska (1998, p. 180) points out “It appears that the term dative-shift is truly a misnomer”.

The crosslinguistic implications can be summarized, according to Levin and Rappaport Hovav (2001), in the following:

- A language with an expression specific to possessors might not be expected to allow the encoding of recipients of ditransitives as allatives (the general encoding for goals), since the semantic expression as possessors is the semantically more specific.
- English does allow recipients of verbs like *give* to be expressed as allatives because given its strict word order there is no other way to focus a recipient.
- But in languages with free word order, like, for instance, Modern Greek or Russian, recipients of verbs like *give* may also be expressed as genitive NPs, as is the case in Modern Greek, or always as dative NPs and never as allatives, as is the case in Russian:

(42) Ja dal Ivanu knigu.
 I.Nom give.PAST Ivan.Dat book.Acc
 “I gave Ivan the book”.

(43) *Ja dal knigu k Ivanu.
 I.Nom give.PAST book.Acc to Ivan.Dat
 “I gave the book to Ivan”.

In fact, there are many languages with only the dative frame or only the double object frame (see, among others, Baker (1997), Dryer (1986)).

5 Conclusion

In conclusion, I have shown that the Modern Greek “genitive” ditransitive alternation is about alternate realizations of recipients, while the Modern Greek double accusative ditransitive alternation is about alternate objects.

Moreover, I have shown that HPSG (Pollard and Sag (1994)) enriched with semantic representations in MRS (Copestake et al. (1999)) constitutes the appropriate theoretical basis for a robust, linguistically-motivated account of ditransitives in Modern Greek, which provides the necessary formal generalizations for the analysis of such arguments in a multilingual context, since MRS structures are easily comparable across languages.

To show this I have considered comparatively both genitive and double accusative ditransitive constructions in Modern Greek (Section (2)), concluding that

while the latter might be considered to conform to the locative alternation in Modern Greek and English, the former are beyond both “(dative) shifts”, as well as “(dative) alternations”.

As a final general comment I need to underline that the MRS-based analysis presented in Section (4) above allows for a linguistically-motivated account of the syntactico-semantic properties of doublets, which avoids the processing load problems that are inseparable from (directional or even bi-directional à la Flickinger (1987)) lexical rule approaches to parsing ditransitive constructions in particular and to development of (the lexicon of) large-scale (computational) grammars of natural language based on HPSG in general.

Consequently, (the lexicon of) large-scale computational grammars may become more efficient, since it needs to depend on fewer or even no lexical rules at all, and thus less complicated for the grammar writer to maintain, as well as to develop further. Here I focused on (some of) the theoretical assumptions upon which the achievement of such a goal can be based realistically.

References

- Anagnostopoulou, Elena. 1999. On Double Object Alternations and Clitics. Ms., University of Crete.
- Arad, Maya. 1998. *VP-Structure and the Syntax-Lexicon Interface*. Ph.D.thesis, University College London, London, UK.
- Baker, Mark C. 1988. *Incorporation - A Theory of Grammatical Function Changing*. Chicago: University of Chicago Press.
- Baker, Mark C. 1997. Thematic Roles and Syntactic Structure. In L. Haegeman (ed.), *Elements of Grammar. Handbook of Generative Syntax*, pages 73–137, Dordrecht: Kluwer.
- Butt, Miriam, Dalrymple, Mary and Frank, Annette. 1997. An architecture for linking theory in LFG. In Miriam Butt and Tracy Holloway King (eds.), *Proceedings of the LFG97 Conference*, University of California, San Diego: CSLI Publications.
- Copestake, Ann, Flickinger, Dan, Pollard, Carl and Sag, Ivan A. 2003. Minimal Recursion Semantics: An Introduction. Revised version of November, 2003 (under review).
- Copestake, Ann, Flickinger, Dan, Sag, Ivan A. and Pollard, Carl J. 1999. Minimal Recursion Semantics: An Introduction. Ms., Stanford University.
- Copestake, Ann, Lascarides, Alex and Flickinger, Dan. 2001. An Algebra for Semantic Construction in Constraint-based Grammars. In *Proceedings of the 39th*

- Annual Meeting of the Association for Computational Linguistics (ACL 2001), Toulouse, France.*
- Davis, Anthony. 1996. *Lexical Semantics and Linking in the Hierarchical Lexicon*. Ph. D.thesis, Stanford University, Stanford.
- den Dikken, M. 1995. *Particles*. Oxford, UK: Oxford University Press.
- Dryer, M.S. 1986. On Primary Objects, Secondary Objects and Antidative. *Language* pages 808–845.
- Flickinger, Daniel. 1987. *Lexical Rules in the Hierarchical Lexicon*. Ph. D.thesis, Stanford University, California.
- Goldberg, Adele. 1995. *Constructions*. Chicago, IL: University of Chicago Press.
- Goldsmith, J. 1980. Meaning and Mechanism in Grammar. In S. Kuno (ed.), *Harvard Studies in Syntax and Semantics*, pages 423–449.
- Green, Georgia. 1974. *Semantics and Syntactic Regularity*. Indiana University Press.
- Gruber, J. S. 1965. *Studies in Lexical Relations*. Ph. D.thesis, MIT.
- Hale, K. and Keyser, J. 1996. On the Double-Object Construction. Ms., MIT.
- Harley, H. 1997. If You Have, You Can Give. *WCCFL* 15, 193–207.
- Jackendoff, Ray S. 1972. *Semantic Interpretation in Generative Grammar*. Cambridge, MA: MIT Press.
- Kratzer, A. 1993. The Event Argument and the Semantics of Voice. Ms., University of Massachusetts at Amherst.
- Krifka, Manfred. 1999. Manner in Dative Alternation. *WCCFL* 18, 260–271.
- Larson, R.K. 1988. On the Double Object Construction. *Linguistic Inquiry* 19, 335–331.
- Levin, Beth and Rappaport Hovav, Malka. 2001. What Alternates in the Dative Alternation? Colloquium Series, Department of Linguistics and Philosophy, MIT, Cambridge, MA, November 9, 2001.
- Oehrle, R.T. 1975. *The Grammatical Status of the English Dative Alternation*. Ph. D.thesis, MIT.
- Pesetsky, David. 1995. *Zero Syntax*. Cambridge, MA: MIT Press.
- Pinker, Steven. 1989. *Learnability and Cognition*. MIT Press.

- Pollard, Carl and Sag, Ivan A. 1994. *Head-Driven Phrase Structure Grammar*. Chicago: University of Chicago Press.
- Siewierska, A. 1998. Languages with and without objects: The Functional Grammar Approach. In *Languages in Construct 1*, pages 173–190.
- Wechsler, Stephen. 1995. *The Semantic Basis of Argument Structure*. Stanford: CSLI Publications, series: *Dissertations in Linguistics*, Joan Bresnan, Sharon Inkelaş, William J. Poser, and Peter Sells (eds.).

Constituency, word order and focus projection

Takafumi Maekawa

University of Essex

Proceedings of the 11th International Conference on
Head-Driven Phrase Structure Grammar

Center for Computational Linguistics, Katholieke Universiteit Leuven

Stefan Müller (Editor)

2004

Stanford, CA: CSLI Publications

pages 168–188

Maekawa, Takafumi. 2004. Constituency, word order and focus projection. In Stefan Müller (ed.), *Proceedings of the 11th International Conference on Head-Driven Phrase Structure Grammar*, Center for Computational Linguistics, Katholieke Universiteit Leuven, 168–188. Stanford, CA: CSLI Publications. DOI: 10.21248/hpsg.2004.10.



Abstract

In this study we show that constituency is of limited importance for a proper treatment of the interaction between the linear position of a *wa*-marked nominal in a Japanese sentence and possible domains of contrastive focus, and that constraints concerning contrastive focus should be represented in terms of linear order and not constituency. Linearisation HPSG, where linear order is independent from constituency, provides a good basis for an analysis. Some constraints are provided in terms of order domains, and it is shown that these constraints can deal with the phenomena in question, and that the cases problematic for the constituency-based analyses can also be accounted for by our analysis.

1 Introduction

The most widely adopted view of word order within the framework of HPSG is that a set of linear precedence (LP) rules state the possible permutations of constituent in a local tree (see, e.g., Pollard and Sag 1987, 1994).^{*} In such a framework, there are at least two possible analyses of a relatively flexible word order of Japanese illustrated by (1), which has been often called ‘scrambling’.

- (1) a. Taroo-ga kesa tukue-ni hana-o oita
Taro-NOM this morning desk-LOC flower-ACC put
‘Taro put the flower on the desk this morning’
- b. Kesa tukue-ni Taroo-ga hana-o oita
this morning desk-LOC Taro-NOM flower-ACC put

First, we might assume a flat structure like (2) in which a lexical verbal head and all of its dependents form a single constituent.¹

^{*} I would like to thank Bob Borsley for his valuable comments and discussions. Thanks are due to participants at HPSG 2004 for their feedback and discussions. I am also grateful to Doug Arnold and three anonymous reviewers for HPSG 2004 for their comments on earlier versions of this paper. Any shortcomings are my responsibility. I gratefully acknowledge the generous financial assistance from the Department of Language and Linguistics, University of Essex, which enabled me to take part in HPSG 2004.

¹ There have been alternative ways proposed to build a flat structure in HPSG. See Alexopoulou and Kolliakou (2002), Borsley (1989, 1995) and Pollard (1994) for examples.

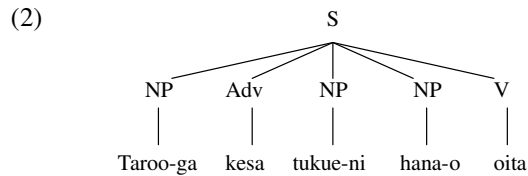

Then, the general LP rule (3) can alone give an account for the word order variation in (1).

$$(3) \quad [] \leq \text{HEAD}[\text{LEX} +]$$

This LP rule states that a lexical head follows any sister. Conforming to this rule, the lexical head daughter *oita* ‘put’ follows all its sisters both in (1a) and (1b). No further rules are needed to predict the word order variation as in (1). Second, we might assume a binary branching structure like the following.

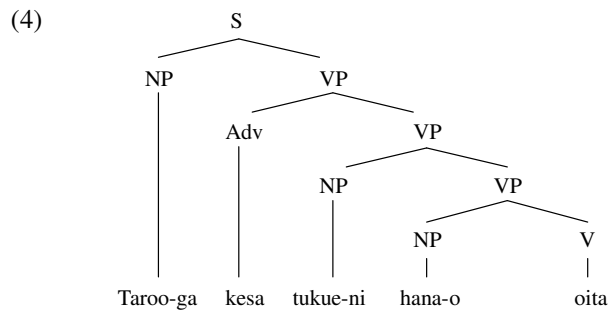

A binary branching constituent structure has been advanced for German clauses in HPSG (see, e.g., Kathol 2000 and Müller 2002), so it might be quite reasonable to assume it for Japanese clauses as well. There are several possible ways to represent the relatively free constituent order in binary branching: to assume a set, rather than a list, of valence information (Gunji 1986; Hinrichs and Nakazawa 1989; Pollard 1996; also see Müller 2004b); to relax the requirement that elements should be removed from the list in order of their obliqueness (as suggested, but rejected, by Müller 2004a); to assume a lexical rule that licenses alternative orders for SUBCAT lists (Uszkoreit 1986).² Finally, we might assume a view in which linear order is independent to a considerable extent from constituency and is analysed in terms of a separate level of ‘order domains’ (Pollard et al. 1993; Reape 1994; Kathol 2000). In this approach, the order variation of a sentence would be represented in the DOM(AIN) list, no matter which constituent structure it has.

² See Müller (2004a) for the details and problems of these approaches.

- (5) $\left[\begin{array}{l} \text{DTRS} \dots \\ \text{DOM} \langle \text{Taroo} - \text{ga}, \text{kesa}, \text{tukue} - \text{ni}, \text{hana} - \text{o}, \text{oita} \rangle \end{array} \right]$

In this study these three approaches will be compared, and we shall argue that the connection between the linear position of a *wa*-marked nominal in a sentence and possible domains of contrastive focus provides support for the third, order domain approach. Some constraints will be provided in terms of order domains, and we will show that they can deal with the phenomena in question, and that the cases problematic for the constituency-based analyses can be accounted for by our analysis.

The organisation of this study is as follows. In section 2 we shall survey the basic data, and see that the phenomena in question seem to be similar to those accounted for in terms of focus projection. In section 3 we shall compare the flat structure analysis and binary branching structure analysis introduced above, and argue that neither of them is satisfactory. Section 4 will present an alternative analysis in terms of order domains. Section 5 is the conclusion.

2 Particle *wa* and an extension of contrastive focus

The particle *wa* indicates that some material containing it carries a ‘contrastive focus’ interpretation.³ In (6) the object *sakana* ‘fish’ is marked with *wa* and it has a contrastive focus reading. Here and throughout, a domain of contrastive focus is marked with braces. Thus, the sentence implies that Taro ate fish but he did not eat anything else.

- (6) Taroo-wa {sakana-wa} tabeta
 Taro-TOP fish-CF ate
 ‘Taro ate fish (but ate nothing else).’

As (7) shows, the domain of contrastive focus can be extended beyond the element marked with *wa* (Noda 1996; see Choi 1999 for analogous data in Korean).

- (7) Taroo-wa {sakana-wa tabeta}
 Taro-TOP fish-CF ate
 ‘Taro ate fish (but did nothing else).’

In (7) *sakaana-wa tabeta* ‘ate fish’, and not just *sakaana-wa*, carries a contrastive

³ As illustrated by the examples below, the same particle functions as a topic marker as well, but this aspect of *-wa* is irrelevant to the main subject. In the rest of this paper, the topic marker is glossed as TOP and the contrastive focus marker as CF.

focus interpretation, and the sentence implies that Taro ate fish but did not do anything else, such as playing tennis. If there is some other element between the *wa*-marked nominal and the verb, it can be in the focus domain.

- (8) a. Taroo-*wa* {hana-*wa* tukue-*ni* oita}
 Taro-TOP flower-CF desk-LOC put
 ‘Taro put the flowers on the desk (but did nothing else).’
 b. Taroo-*wa* {sakana-*wa* resutoran-*de* tabeta}
 Taro-TOP fish-CF restaurant-LOC ate
 ‘Taro ate fish at the restaurant (but did nothing else).’

In (8) there is another complement *tukue-ni* ‘on the desk’ (a) and an adjunct *resutoran-de* ‘at the restaurant’ (b) between the *wa*-marked complement and the verb, and they can be included in the focus domain, as the translation shows.

The most plausible way to analyse the extension of contrastive focus would be to take it as an instance of ‘focus projection’. In languages such as English and German, focus can be extended beyond the element that carries pitch accent. Focus projection, which has been a dominant approach to this phenomenon, argues that in each local tree a focus-background structure for the mother is computed from the focus-background structure of the daughter constituents (see, e.g., Jackendoff 1972 and Selkirk 1995). Recent HPSG analyses are along the same lines (Engdahl and Vallduví 1996; Alexopoulou and Kolliakou 2002; De Kuthy 2002; De Kuthy and Meurers 2003). In De Kuthy and Meurers’s (2003) system, for example, if a daughter with the focus projection potential (FPP *plus*) is focused, the mother can be in the focus.⁴ The broad contrastive focus as in (7) and (8) might seem to be accounted for in an analogous way by assuming either binary branching or a flat structure: the constituent is given contrastive focus if one of its non-head daughters (e.g., *sakana* ‘fish’ in (7)) is marked with contrastive *wa*.⁵

In the next section, we shall look at how the binary branching and the flat structure analysis deal with the phenomena in question, and point out that neither of them is satisfactory.

3 Constituency-based analyses

This section will compare the possible constituency-based approaches to order variation, i.e., a flat structure analysis and binary branching structure analysis.

⁴ The FPP feature is assumed for *synsem* objects so that verbs can lexically mark which of their arguments can project focus. See De Kuthy and Meurers (2003) for details.

⁵ It is assumed here that the topic is combined with the rest of the sentence as a filler, along the same lines as the English topicalisation (Pollard and Sag 1994).

3.1 Flat structure

The position of a *wa*-marked nominal and its interaction with possible domains of contrastive focus pose a problem for the flat structure analysis.

- (9) a. [S Taroo-ga tukue-ni hana-wa oita] (-to kiita)
 Taro-NOM desk-LOC flower-CF put that heard
 ‘(I hear that) Taro put the flower on the desk.’
- b. [S hana-wa Taroo-ga tukue-ni oita] (-to kiita)
 flower-CF Taro-NOM desk-LOC put that heard
 ‘(I hear that) Taro put the flower on the desk.’

The sentences in (9) each contain a *wa*-marked nominal. It is immediately preceding the verb in (9a), but is in the initial position of the S in (9b). If we adopt the approach to focus projection discussed above along with a flat structure, these sentences should have the same possible focus domains: the *wa*-marked nominal and its mother S. The fact is, however, that (9a) does not have an S focus interpretation while (9b) does. The interpretation of the latter is illustrated by (10).

- (10) [S₁ hana-wa Taroo-ga tukue-ni oita] -ga
 flower-CF Taro-NOM desk-LOC put -but
 [S₂ hon-wa Jiroo-ga tana-ni narabeta] (-to kiita)
 book-CF Jiro-NOM shelf-LOC set that heard
 ‘(I hear that) Taro put the flower on the desk but Jiro set the books on the shelf.’

In (10) the S in (9b) (marked as S₁) is connected with another clause (S₂) with a disjunctive conjunction *-ga* ‘but’ so that S₁ is in the contrastive relation with S₂; both clauses have a *wa*-marked element in its initial position, and they have all different elements. Thus, it would be possible to say that the whole of S₁ (and S₂) carries contrastive focus. Now let us look at (11), where (9a) is contrasted with another sentence.

- (11) # [S₁ Taroo-ga tukue-ni hana-wa oita] -ga
 Taro-NOM desk-LOC flower-CF put -but
 [S₂ Jiroo-ga tana-ni hon-wa narabeta] (-to kiita)
 Jiro-NOM shelf-LOC book-CF set that heard
 ‘(I hear that) Taro put the flower on the desk but Jiro set the books on the shelf.’

In (11) the S in (9a) is contrasted with another S, and is intended to have a

sentential contrastive focus. The infelicity of (11) (marked by #) suggests that (9a) does not have a S focus interpretation, and gives evidence that the *wa*-marked NP in the middle of the S cannot extend contrastive focus to the whole S.

A construction such as the following provides another problem for the flat structure analysis.⁶

- (12) Taroo-ga akai {uwagi-wa kiru} -ga
 Taroo-NOM red jacket-CF wear but
 onazi iro-no {zubon-wa kiraida} (-to kiita).
 same colour-GEN trousers-CF hate that heard
 ‘Taro wears a red jacket, but hates trousers of the same colour.’

The structure for the first clause of (12) is (13).

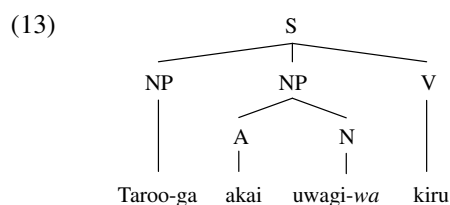

In (12) it is impossible to regard the adjective as a part of the focus domain; the modifiers of the noun in these clauses, *akai* ‘red’ and *onazi iro-no* ‘of the same colour’, both refer to a red colour, and there is no sense in contrasting the same colour. Hence they should be excluded from the focus domain: only the V and a part of the NP carry contrastive focus. If we assumed (13), however, the possible focus domains that could be represented would be N, NP and S only, and we could not analyse a case like (12).

3.2 Binary branching structure

In the last subsection, we saw that we could not deal with the extension of focus in (9a). The following fact suggests that what carries a contrastive focus in (9a) is just part of the S.

- (14) [_{S1} Taroo-ga tukue-ni hana-wa oita] -ga
 Taro-NOM desk-LOC flower-CF put -but
 [_{S2} hon-wa narabe-nak-atta] (-to kiita)
 book-CF set-NEG-PAST that heard
 ‘(I hear that) Taro put the flower on the desk, but he didn’t set the

⁶ I would like to thank Shūichi Yatabe for bringing this type of construction to my attention.

books there.'

As is well known, it is allowed in Japanese to leave unexpressed the element which refers to who or what has been already introduced in discourse. (14) is such a sentence. As indicated by the translation, it is intended that the second S has a subject, a time and place adverbial coreferential to those of the first S. Since there is no sense in contrasting the coreferential things, therefore, it is possible to say that what are really contrasted in (14) are the remaining parts of the Ss, namely *hana-wa oita* 'put the flowers' in S1 and *hon-wa narabe-nak-atta* 'didn't set the books' in S2. Thus, the contrastive focus domain of (9a) is the part marked with braces in (15).

- (15) [S Taroo-ga tukue-ni { hana-wa oita }] (-to kiita)
 Taro-NOM desk-LOC flower-CF put that heard

The infelicity of (11), where (9a) is contrasted with another S, is due to the fact that only a part of the S carries contrastive focus in the context where the whole S focus is intended. Therefore, we need an alternative analysis which can capture the fact that the *wa*-marked element in (9a) does not extend its focus to the whole S and its contrastive focus domain is just part of the S, as marked in (15).

One might argue that a binary branching approach would be such an alternative. We could assume the following binary branching structure for (9a).

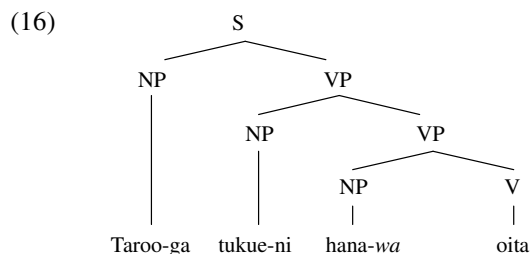

The contrastive focus domain of (9a), shown in (15), corresponds to the lower VP in (16). The broad contrastive focus can be dealt with on the basis of the traditional conception of focus projection introduced in the last section: the lower VP in (16) is given contrastive focus since its non-head daughter (i.e., *hana* 'flower') is marked with *wa*.

However, an example like the following poses a problem for this analysis.

- (17) [S₁ Taroo-ga hana-wa tukue-ni oita] -ga
 Taro-NOM flower-CF desk-LOC put -but
 [S₂ hon-wa yuka-ni oita] (to kiita)
 book-CF floor-LOC put that heard

‘(I hear that) Taro put the flower on the desk, but the books on the floor’

The binary branching structure for the S1 of (17) would be something like (18).

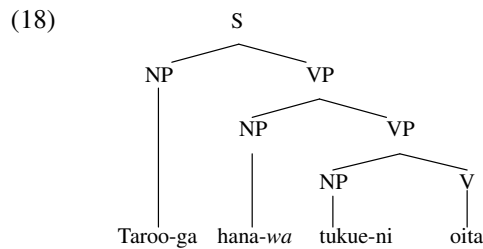

As the translation indicates, sentence (17) is intended to carry an interpretation where Taro’s putting the flower on the desk and his putting the books on the floor is compared. Therefore, the contrastive focus domain might seem to correspond to the upper VP in (18). Note, however, that both S1 and S2 include the same verb *oita* ‘put’. There is no sense in contrasting the same element, so the verb should be excluded from the domain of contrastive focus. Therefore, what are really contrasted in (17) are the remaining parts of the Ss, which are marked by the braces in (19).

- (19) [s Taroo-ga { hana-wa tukue-ni } oita] -ga
 Taro-NOM flower-CF desk-LOC put -but
 [s { hon-wa yuka-ni } oita] (-to kiita)
 book-CF floor-LOC put that heard

Such a domain cannot be represented with a binary branching structure in (18).

One might argue that these cases would be accounted for with binary branching if we assumed an analogue of verb movement.^{7,8} A verb movement analysis of (19) would have the representation in (20), where it is assumed that a SUBCAT list of the verbal trace contains the verb and its all arguments (Müller 2004b; Netter 1992, 1998).

⁷ Some HPSG researches have assumed such a mechanism in order to describe the finite verb position in German (Frank 1994; Jacobs 1986; Kiss and Wesche 1991; Meurers 2000; Müller 2004b; Müller and Kasper 2000; Netter 1992, 1998).

⁸ This possibility was pointed out to me by Bob Borsley.

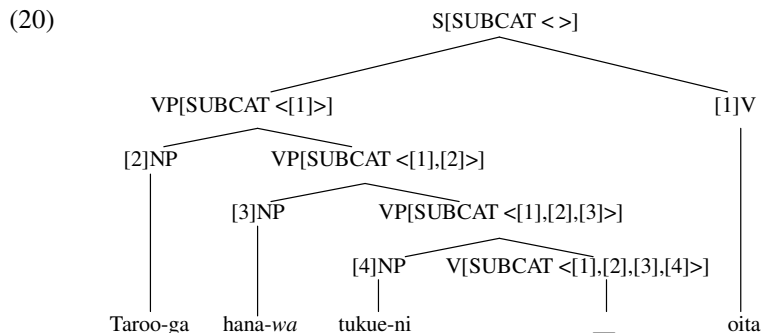

This structure would allow contrastive focus to extend from *hana-wa* to the VP dominating *hana-wa* and *tukue-ni*, which corresponds to the domain marked with the braces in (19). Example (12), however, is problematic for this approach as well. It is repeated in (21)

- (21) Taroo-ga akai {uwagi-wa kiru} -ga
 Taroo-NOM red jacket-CF wear but
 onazi iro-no {zubon-wa kiraida} (to kiita).
 same colour-GEN trousers-CF hate that heard
 ‘(I hear that) Taro wears a red jacket, but hates trousers of the same colour.’

A binary branching structure for this would be (22).

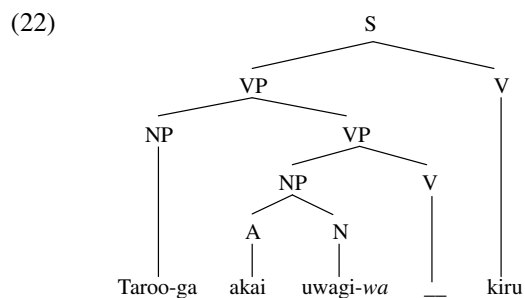

Recall that the adjective should be excluded from the focus domain of (21). If we assumed constituent structure (22), it would still be impossible to represent the contrastive focus domain marked in (21) since the possible focus domains would be N and NP, *uwagi-wa* and *akai uwagi-wa*.

3.3 Summary

In this section we have seen that none of the constituent-based approaches can handle the interaction of word order variation and contrastive focus projection.

This fact suggests that we need an alternative analysis.

Summarising the observations in the last two sections, we get the following pattern of extension of contrastive focus from the *wa*-marked nominal.

- (23) a. {{{{hana-wa}_{F1} Taroo-ga}_{F2} tukue-ni}_{F3} oita}_{F4}
 b. Taroo-ga {{{hana-wa}_{F1} tukue-ni}_{F2} oita}_{F3}
 c. Taroo-ga tukue-ni {{hana-wa}_{F1} oita}_{F2}

Each sentence in (23) has a *wa*-marked nominal in different linear position: the initial position (a), the second position (b), and the third position just before the verb (c). From this, three general points become clear. Firstly, possible domains of contrastive focus change according to the linear position of the *wa*-marked nominal; (23a) has four possible domains, (23b) has three and (23c) has only two. Second, the domain of contrastive focus extends only rightwards on the basis of linearity. Thirdly, there exist domains that do not correspond to any constituent, whether we assume a binary branching or a flat structure; note the domains marked by F2 and F3 in (23a) and F2 in (23b).

These points suggest that constituency is of limited importance for a proper treatment of extension of contrastive focus; it should be more closely related to linear order. Thus, we need an approach where linear order would be independent from constituency, and constraints concerning contrastive focus could be represented on the same level as the former, not the latter. As we will see in the next section, Linearization HPSG provides a good basis for such an approach, so we shall give an alternative analysis within the framework.

4 A Linearization HPSG analysis

In this section, we will provide an alternative analysis of contrastive focus projection. 4.1 sets the framework for our analysis. In 4.2 we shall provide our proposals. Finally, in 4.3 we shall argue that our proposals can deal with the cases which are problematic in the constituency-based approaches.

4.1 Framework

The analysis to be presented below will be largely based on a version of linearisation-based HPSG. In this framework, linear order is represented in a separate level of ‘order domain’, to which ordering constraints apply (see, e.g., Pollard et al. 1993; Reape 1994; and Kathol 2000). Order domains are given as the value of the attribute DOM(AIN). At each level of syntactic combination, the order domain of the mother category is computed from the order domains of the

daughter constituents. We assume, along with Reape (1994), Donohue and Sag (1999), Kathol (2000: 101), and Jaeger (2003), that an order domain consists of an ordered list of signs, which we will call ‘DOM elements’.⁹

Next, we assume that a sign has information structure, which is represented as a value of its INFO(RMATION)-STR(UCTURE) (Engdahl and Vallduví 1996; Alexopoulou and Kolliakou 2002; De Kuthy 2002; De Kuthy and Meurers 2003). Its feature geometry would reflect a focus-background structure of a sign, and we assume that each of those features has a list of signs as its value (Engdahl and Vallduví 1996; Alexopoulou 1999; Alexopoulou and Kolliakou 1999). Among those appropriate for INFO-STR, however, the only feature mentioned in this study is CONTR(ASTIVE)-FOC(US). Its value is structure-shared with the sign which is the part of a sentence with contrastive focus.¹⁰

We stated above that a DOM element is a sign, and a sign has information structure. This means that a DOM element include information structure in its internal structure. This latter point has a considerable significance for our analysis in that it enables the information-structural status of DOM elements to be accessible for ordering constraints (see also Jaeger 2003).

4.2 Proposals

Now we propose the following constraint.

$$(24) \quad \left[\begin{array}{l} S \\ \text{DOM} \left\langle \dots, [1] \left[\begin{array}{l} \text{sign} \\ \text{INFO-STR} \mid \text{CONTR-FOC} \langle \{1\} \rangle \end{array} \right] \dots \right\rangle \\ \rightarrow [\text{INFO-STR} \mid \text{CONTR-FOC} \langle \{1\} \rangle] \end{array} \right]$$

(24) states that if the CONTR-FOC value of a DOM element of an S is structure-shared with that DOM element itself, the CONTR-FOC value of the S is structure-shared with the CONTR-FOC value of that DOM element.

There are two cases that are covered by this constraint. One is the case where the DOM element in the antecedent of the constraint (24) is the one licensed by (25).

$$(25) \quad \left[\begin{array}{l} \text{word} \\ \text{NP}_{[wa]} \end{array} \right] \rightarrow [1][\text{INFO-STR} \mid \text{CONTR-FOC} \langle \{1\} \rangle]$$

Constraint (25) states that if a word is marked with *wa*, its CONTR-FOC value is

⁹ The assumption that DOM elements are signs might involve some problems. See Kathol (2000) for discussion.

the sign itself. This is an HPSG-style formalization to the constraint which has already been stated: a *wa*-marked element carries contrastive focus. This corresponds to the narrowest domain of contrastive focus in which the CONTR-FOC value of an S inherits that of the *wa*-marked DOM element which is composed of only one lexical sign.

Another is the case where the DOM element in the antecedent of (24) satisfies the following constraint.

$$(26) \quad \left[\begin{array}{c} \textit{sign} \\ \delta_i[\textit{wa}] \oplus \dots \oplus \delta_n \end{array} \right] \rightarrow [1][\text{INFO-STR} \mid \text{CONTR-FOC}(\{1\})]$$

What (26) says is that if a *wa*-marked element combines with the other DOM element(s) to its right, then the resulting single DOM element should have its CONTR-FOC value structure-shared with that DOM element itself. If there are remaining elements, they are left as separate DOM elements. This is an instance of ‘partial compaction’ which has been discussed by Kathol and Pollard (1995) and Yatabe (1996, 2001). Note that compaction of a *wa*-marked element with the elements to its left is not prevented. However, the resulting DOM element simply does not satisfy the constraint (26), so its CONTR-FOC value would not be structure-shared with the DOM element. Only the DOM element with a *wa*-marked element on its left periphery can satisfy this constraint. Such a DOM element is in turn entitled to occur in the antecedent of constraint (24), in just the same way as a single *wa*-marked element, discussed above. As we shall see below, this is the case where contrastive focus extends beyond the *wa*-marked element.

4.3 Analysis

Combining the constraints introduced above, we can obtain an analysis which predicts the interaction of the linear position of a *wa*-marked nominal and the possible domains of contrastive focus, which was summarised in 3.3 and is repeated here for convenience.

- (27) a. $\{\{\{\{\textit{hana-wa}\}_{F1} \textit{Taroo-ga}\}_{F2} \textit{tukue-ni}\}_{F3} \textit{oita}\}_{F4}$
 b. $\textit{Taroo-ga} \{\{\{\textit{hana-wa}\}_{F1} \textit{tukue-ni}\}_{F2} \textit{oita}\}_{F3}$
 c. $\textit{Taroo-ga} \textit{tukue-ni} \{\{\textit{hana-wa}\}_{F1} \textit{oita}\}_{F2}$

4.3.1 Narrow domain of contrastive focus

Let us start with the cases where the domain of contrastive focus is the narrowest, confined to a *wa*-marked element. Let us look at (28), which represents the S node for the contrastive focus domain marked with F1 of (27a).

¹⁰ Thus, the value of the CONTR-FOC and DOM feature is a list of signs in our system.

$$(28) \quad \left[\begin{array}{l} \text{INFO - STR | CONTR - FOC } \langle [1] \rangle \\ \text{DOM } \left\langle [1] \left[\begin{array}{l} \langle \text{hana - wa} \rangle \\ \text{CONTR - FOC } \langle [1] \rangle \end{array} \right], [\text{Taroo - ga}], [\text{tsukue - ni}], [\text{oita}] \right\rangle \end{array} \right]$$

Constraint (25) is responsible for the structure-sharing (tagged [1]) between the CONTR-FOC value of the *wa*-marked DOM element and the DOM element itself. Then the CONTR-FOC feature of S inherits the value [1], which is a case covered by (24). This is the process in which a single *wa*-marked element is licensed to carry contrastive focus in the S sign.

The narrowest domain in (27b,c), with a *wa*-marked nominal in a position different from the above, are analysed in an analogous way. (29a) and (29b) are the representations of the S node with F1 domain of (27b) and (27c), respectively.

$$(29) \text{ a. } \left[\begin{array}{l} \text{INFO - STR | CONTR - FOC } \langle [2] \rangle \\ \text{DOM } \left\langle [\text{Taroo - ga}], [2] \left[\begin{array}{l} \langle \text{hana - wa} \rangle \\ \text{CONTR - FOC } [2] \end{array} \right], [\text{tsukue - ni}], [\text{oita}] \right\rangle \end{array} \right]$$

$$\text{b. } \left[\begin{array}{l} \text{INFO - STR | CONTR - FOC } \langle [3] \rangle \\ \text{DOM } \left\langle [\text{Taroo - ga}], [\text{tsukue - ni}], [3] \left[\begin{array}{l} \langle \text{hana - wa} \rangle \\ \text{CONTR - FOC } [3] \end{array} \right], [\text{oita}] \right\rangle \end{array} \right]$$

They are different from the previous one in the position of the *wa*-marked element in the DOM list: in (29a) it is in the second position of the list while in (29b) it is in the third position. As in the previous case, however, the INFO-STR|CONTR-FOC value of the S is structure-shared with the value of the CONTR-FOC feature of the *wa*-marked element. Thus, in the narrowest domain cases, the S's CONTR-FOC value inherits that of a *wa*-marked element, in whatever position the latter is.

4.3.2 Broad domain of contrastive focus

Next let us turn to the cases where contrastive focus is extended beyond the *wa*-marked element; that is, the domains marked F2 to F4 in (27).

Let us start with the case which was provided as problematic to a flat structure approach, i.e., (9a). This corresponds to the contrastive focus domain marked as F2 in (27c), which is repeated here.

$$(30) \quad \begin{array}{l} \text{Taroo-ga} \quad \text{tukue-ni} \quad \{ \text{hana-wa} \quad \text{oita} \}_{F2} \\ \text{Taro-NOM} \quad \text{desk-LOC} \quad \text{flower-CF} \quad \text{put} \end{array}$$

In our analysis, the S sign of (30) has the following schematic analysis.

$$(31) \quad \left[\begin{array}{l} \text{INFO - STR | CONTR - FOC } \langle [4] \rangle \\ \text{DOM} \left\langle \left[\left[\langle \text{Taroo - ga} \rangle \right] \left[\langle \text{tukue - ni} \rangle \right] \right]_{[4]} \left[\langle \text{hana - wa, oita} \rangle \right] \right\rangle \left[\text{CONTR | FOC } \langle [4] \rangle \right] \end{array} \right]$$

The *wa*-marked element, *hana-wa* ‘flower-CF’, is partially compacted with the element to its right, *oita* ‘put’, and they form a single DOM element. The remaining elements are left as separate DOM elements. Due to (26), then, a DOM element constructed by compaction has its CONTR-FOC value structure-shared with the DOM element itself. Finally, following (24), the CONTR-FOC value of the S is structure-shared with the CONTR-FOC value of this DOM element. In this way the F2 domain in (30) is licensed to carry contrastive focus, and this is how our analysis accounts for the case problematic to the flat structure approach.

We provided (17) as a counterexample to the binary branching approach. It corresponds to the contrastive focus domain marked as F2 in (27b) repeated here.

$$(32) \quad \begin{array}{l} \text{Taroo-ga} \quad \{ \text{hana-wa} \quad \text{tukue-ni} \}_{\text{F2}} \quad \text{oita} \\ \text{Taro-NOM} \quad \text{flower-CF} \quad \text{desk-LOC} \quad \text{put} \end{array}$$

Its S sign would be analysed in the following way.

$$(33) \quad \left[\begin{array}{l} \text{INFO - STR | CONTR - FOC } \langle [5] \rangle \\ \text{DOM} \left\langle \left[\langle \text{Taroo - ga} \rangle \right]_{[5]} \left[\langle \text{hana - wa, tukue - ni} \rangle \right]_{[5]} \left[\langle \text{oita} \rangle \right] \right\rangle \left[\text{CONTR - FOC } \langle [5] \rangle \right] \end{array} \right]$$

In (33), *hana-wa* ‘flower-CF’ is partially compacted with the element immediately to its right, *tukue-ni* ‘desk-LOC’, and they form a single DOM element, which is tagged [5]. The remaining elements, *Taroo-ga* ‘Taro-NOM’ and *oita* ‘put’, are left as separate DOM elements. Following (24), the CONTR-FOC value of the compacted DOM element is [5]; it is structure-shared with the DOM element itself. The CONTR-FOC value of the S is structure-shared with the CONTR-FOC value of this DOM element, and hence it is also tagged [5]. The example problematic for the binary branching approach can thus be given an analysis in our system.

As has been already clear from the above, what we have called a broad domain of contrastive focus corresponds to a DOM element constructed via compaction involving a *wa*-marked element. Constraint (26) entails that a DOM element can satisfy it as long as a *wa*-marked element has been combined with other elements to its right. This means that such a DOM element can extend rightwards until the end of the sentence. This in turn means that (27a) has the three possibilities shown in (34) for DOM elements eligible for constraint (26).

(27a) is repeated in (35). (34) shows only the PHON value of the DOM elements.

- (34) a. <*hana-wa, Taroo-ga*>
 b. <*hana-wa, Taroo-ga, tukue-ni*>
 c. <*hana-wa, Taroo-ga, tukue-ni, oita*>

(35) {{{{*hana-wa*}_{F1} *Taroo-ga*}_{F2} *tukue-ni*}_{F3} *oita*}_{F4}

As is clear from these, each possible compacted DOM element shown in (34) corresponds to the broad domains of contrastive focus marked F2 to F4 in (35). Thus, constraints provided in 4.2 can predict these contrastive focus domains, and all other broad domains shown in (27) would be predicted along these lines: F2 to F4 domains are made by combining a *wa*-marked element with other elements to its right one at a time.

The fact observed in 3.1 that (10) is acceptable whereas (11) is not is accounted for along these lines. Example (10) is repeated in (36a), and (11) in (36b).

- (36) a. [_{S1} *hana-wa* *Taroo-ga* *tukue-ni* *oita*] -ga
 flower-CF *Taroo-NOM* *desk-LOC* *put* -but
 [_{S2} *hon-wa* *Jiroo-ga* *tana-ni* *narabeta*] (-to *kiita*)
 book-CF *Jiro-NOM* *shelf-LOC* *set* *that* *heard*
 ‘(I hear that) Taro put the flower on the desk but Jiro set the books on
 the shelf.’
- b. # [_{S1} *Taroo-ga* *tukue-ni* *hana-wa* *oita*] -ga
 Taroo-NOM *desk-LOC* *flower-CF* *put* -but
 [_{S2} *Jiroo-ga* *tana-ni* *hon-wa* *narabeta*] (-to *kiita*)
 Jiro-NOM *shelf-LOC* *book-CF* *set* *that* *heard*
 ‘(I hear that) Taro put the flower on the desk but Jiro set the books on
 the shelf.’

In both, S1 is contrasted with S2 so that it is intended that whole of S1 (and S2) has contrastive focus. The contrastive focus domain in (36a) is licensed in the way discussed in the last paragraph. These Ss have a *wa*-marked element in their initial position. This ensures that *hana-wa* and *hon-wa* can combine with all other DOM elements (i.e., total compaction) to be eligible for constraint (26) since they are all to its right. Let us turn to (36b). In this sentence, the *wa*-marked element is not in the initial position. In our system, a broad contrastive focus interpretation can be given to a DOM element only if the *wa*-marked element is compacted with DOM elements to its right. However, in order to get the whole S focus interpretation, the *wa*-marked element in (36b) would have to be combined not

only with the element to its right but also with the elements to its left. Recall that compaction of a *wa*-marked element with the elements to its left is not prevented. However, the resulting DOM element simply does not satisfy constraint (26), so its CONTR-FOC value would not be structure-shared with the DOM element. The infelicity of (36b) is, thus, attributed to the fact that a sentential contrastive focus domain in (36b) would involve *Taroo-ga* and *tukue-ni* which are to its left.

For the same reason as (36b), such contrastive focus domains as shown below, where the domain is extended from the *wa*-marked element to its left, are predicted to be unacceptable.

- (37) a. {Taroo-ga hana-wa} tukue-ni oita
 b. {Taroo-ga {tukue-ni hana-wa}} oita

This is borne out by the following data.

- (38) a. # [_{S1} { Taroo-ga hana-wa } tukue-ni oita] -ga
 Taro-NOM flower-CF desk-LOC put -but
 [_{S2} { Jiroo-ga hon-wa } soko-ni oita] (-to kiita)
 Jiro-NOM book-CF there-LOC set that heard
 ‘(I hear that) Taro put the flower on the desk but Jiro put the books there.’
- b. # [_{S1} Taroo-ga { tukue-ni hana-wa } oita] -ga
 Taro-NOM desk-LOC flower-CF put -but
 [_{S2} { tana-ni hon-wa } oita] (-to kiita)
 shelf-LOC book-CF put that heard
 ‘(I hear that) Taro put the flower on the desk but put the books on the shelf.’

In (38a, b), (a) and (b) of (37) are respectively set in the context where the sequences marked with braces have contrastive focus: the verbs in both clauses are the same, and the locative arguments of S1 and S2 in (38a) and the subject of S1 and the null argument of S2 in (38b) have the same reference. As predicted, (38a, b) are both unacceptable.

We now move on to example (12), which we presented as a counterexample to both the binary and the flat structure analysis. The example, once repeated in (21), is again repeated here for convenience.

- (39) Taroo-ga akai {uwagi-wa kiru} -ga
 Taroo-NOM red jacket-CF wear but
 onazi iro-no {zubon-wa kiraida} (-to kiita).
 same colour-GEN trousers-CF hate that heard

‘(I hear that) Taro wears a red jacket, but hates trousers of the same colour.’

The first clause of (39) would be analysed in the following way. The adjective *akai* ‘red’ would be combined with the noun *uwagi-wa* ‘jacket-CF’ at some point of combination in constituent structure, but in the order domain they can be separated. This is possible because of the assumption that an order domain is independent of constituency. Instead, *uwagi-wa* combines with the element to its right, *kiru* ‘wear’, by partial compaction. The S sign of this clause is as follows.

$$(40) \quad \left[\begin{array}{l} \text{INFO-STR | CONTR-FOC} \langle [6] \rangle \\ \text{DOM} \left\langle \left[\left[\langle \text{Taroo-ga} \rangle \right], \left[\langle \text{akai} \rangle \right] \right] [6] \left[\left[\langle \text{uwagi-wa, kiru} \rangle \right] \right] \right\rangle \left[\text{CONTR-FOC} \langle [6] \rangle \right] \end{array} \right]$$

Due to (26), the DOM element constructed via partial compaction has its CONTR-FOC value structure-shared with the DOM element itself. Then, following (24), the CONTR-FOC value of the S is structure-shared with the CONTR-FOC value of this DOM element. This analysis is supported by the fact that the noun and its modifier do not always have to be adjacent.

$$(41) \quad \begin{array}{l} \text{Akai, Taroo-ga} \quad \{ \text{uwagi-wa} \quad \text{kiru} \} \quad \text{-ga} \\ \text{red} \quad \text{Taroo-NOM} \quad \text{jacket-CF} \quad \text{wear} \quad \text{but} \\ \text{onazi iro-no} \quad \{ \text{zubon-wa} \quad \text{kiraida} \} \quad (\text{-to kiita}). \\ \text{same colour-GEN} \quad \text{trousers-CF} \quad \text{hate} \quad \text{that heard} \\ \text{‘(I hear that) Taro wears a red jacket, but hates trousers of the same} \\ \text{colour.’} \end{array}$$

In (41), which in my judgement is acceptable at least in colloquial speech, *akai* ‘red’ is in front of the sentence, and is separated from *uwagi-wa* ‘jacket-CF’, intervened by *Taroo-ga* ‘Taro-NOM’. The order domain of (41) would have the following structure.

$$(42) \quad \left[\begin{array}{l} \text{INFO-STR | CONTR-FOC} \langle [7] \rangle \\ \text{DOM} \left\langle \left[\langle \text{akai} \rangle \right], \left[\left[\langle \text{Taroo-ga} \rangle \right] \right] [7] \left[\left[\langle \text{uwagi-wa, kiru} \rangle \right] \right] \right\rangle \left[\text{CONTR-FOC} \langle [7] \rangle \right] \end{array} \right]$$

The order domains in (40) and (42) are just alternatives, the only difference being the position of *akai*; it is separated from *uwagi-wa* in (42), and is in the initial position of the DOM list.

5 Conclusion

We showed that constituency is much less significant than linear order for a proper treatment of the interaction between the linear position of a *wa*-marked nominal in a sentence and possible domains of contrastive focus, and that constraints concerning contrastive focus should be represented in terms of linear order and not constituency. We argued that Linearisation HPSG, where linear order is independent from constituency, provides a good basis for this. Finally, we gave some constraints in terms of order domains that can deal with the phenomena in question, and showed that cases problematic for the constituency-based analyses can also be accounted for by our analysis. If our analysis is on the right track, it suggests that Linearization HPSG is important not only for representing word order but also for the analysis of information structure and its interaction with syntax as well.

References

- Alexopoulou, Theodra and Kolliakou, Dimitra. 2002. On linkhood, topicalization and clitic left dislocation. *Journal of Linguistics* 38, 193–245.
- Borsley, Robert D. 1989. An HPSG approach to Welsh. *Journal of Linguistics* 25, 333–354.
- Borsley, Robert D. 1995. On some similarities and differences between Welsh and Syrian Arabic. *Linguistics* 33, 99–122.
- Calcagno, Mike. 1993. Toward a linearization-based approach to word order variation to Japanese. In A. Kathol and C. Pollard (eds.), *Papers in Linguistics*, 26–45.
- Choi, Hye-Won. 1999. *Optimizing Structure in Context*. Stanford: CSLI Publications.
- De Kuthy, Kordula. 2002. *Discontinuous NPs in German – A Case Study of the Interaction of Syntax, Semantics and Pragmatics*. Stanford, CA: CSLI Publications.
- De Kuthy, Kordula and Meurers, Walt Detmar. 2003. The secret life of focus exponents, and what it tells us about fronted verbal projections. In S. Müller (ed.), *Proceedings of the HPSG03 Conference*. Stanford: CSLI Publications.
- Donohue, Cathryn and Sag, Ivan A.. 1999. Domains in Warlpiri. Ms. Stanford University.
- Engdahl, Elisabeth and Vallduví, Enric. 1996. Information packaging in HPSG. In C. Grover and E. Vallduví (eds.), *Edinburgh Working Papers in Cognitive Science, vol 12: Studies in HPSG*, 1–31.

- Frank, Anette. 1994. Verb second by lexical rule or by underspecification. *Arbeitspapiere des SFB 340 No. 43*, IBM Deutschland GmbH, Heidelberg.
- Gunji, Takao. 1986. Subcategorization and Word Order. In W. J. Poser (ed.), *Papers from the Second International Workshop on Japanese Syntax*, 1–21. Stanford: CSLI Publications.
- Hinrichs, Erhard W. and Nakazawa, Tsuneko. 1989. Subcategorization and VP Structure in German. In *Aspects of German VP Structure*, SfS-Report-01-93, Eberhard-Karls-Universität, Tübingen.
- Jackendoff, Ray. 1972. *Semantic Interpretation in Generative Grammar*. Cambridge, MA: MIT Press.
- Jacobs, Joachim. 1986. The syntax of focus and adverbials in German. In W. Abraham and S. de Meij (eds.), *Topic, Focus and Configurationality. Paper from the 6th Groningen Grammar Talks, Groningen, 1984*. Amsterdam/Philadelphia: John Benjamins Publishing Company.
- Kathol, Andreas. 2000. *Linear Syntax*. Oxford: Oxford University Press.
- Kathol, Andreas. and Carl Pollard. 1995. Extraposition via complex domain formation. In *33rd Annual Meeting of the ACL*, 174–180. San Francisco: Morgan Kaufmann
- Kiss, Tibor and Wesche, Birgit. 1991. Verb Order and Head Movement. In O. Herzog and C.-R. Rollinger (eds.), *Text Understanding in LILOG*, 216–242. Berlin/Heidelberg/New York: Springer-Verlag.
- Meurers, Walt Detmar. 2000. Lexical Generalizations in the Syntax of German Non-Finite Constructions. *Arbeitspapiere des SFB 340 No. 145*, Eberhard-Karls-Universität, Tübingen.
- Müller, Stefan. 2004a. Continuous and discontinuous constituents? A comparison between syntactic analyses for constituent order and their processing systems. *Research on Language and Computation 2*, 209–257.
- Müller, Stefan. 2004b. An analysis of depictive secondary predicates in German without discontinuous constituents. In S. Müller (ed.), *Proceedings of the HPSG04 Conference*. Stanford: CSLI Publications.
- Müller, Stefan and Kasper, Walter. 2000. HPSG analysis of German. In Wahlster (ed.), *VerbMobil: Foundation of Speech-to-Speech Translation*, 238–253. Berlin/Heidelberg/New York: Springer-Verlag.
- Netter, Klaus. 1992. On non-head non-movement. An HPSG treatment of finite verb position in German. In Görz (ed.), *Konvens 92.1. 'Konferenz Verarbeitung natürlicher Sprache'*. 218–227. Berlin/Heidelberg/New York: Springer-Verlag.
- Netter, Klaus. 1998. *Functional Categories in an HPSG for German*. Saarbrücken Dissertations in Computational Linguistics and Language Technology, No. 3.

Deutsches Forschungszentrum für Künstliche Intelligenz und Universität des Saarlandes, Saarbrücken.

- Noda, Hisashi. 1996. 'Wa' to 'Ga' ['Wa' and 'Ga']. Tokyo: Kuroshio.
- Pollard, Carl. 1994. Toward a unified account of passive in German. In J. Nerbonne, *et al.* (eds.), 273–96.
- Pollard, Carl. 1996. On head non-movement. In H. Bunt and A. van Horck (eds.), *Discontinuous Constituency*, 279–305. Berlin, New York: Mouton de Gruyter.
- Pollard, Carl, Kasper, Robert and Levine, Robert. 1994. Studies in constituent ordering: Towards a theory of linearization in Head-driven Phrase Structure Grammar. Research Proposal to the National Science Foundation, Ohio State University.
- Pollard, Carl and Sag, Ivan A. 1989. *Information-Based Syntax and Semantics*. Stanford: CSLI Publications.
- Pollard, Carl and Sag, Ivan A. 1994. *Head-Driven Phrase Structure Grammar*. Chicago: University of Chicago Press.
- Reape, Mike. 1994. Domain union and word order variation in German. In J. Nerbonne, *et al.* (eds.), *German in Head-Driven Phrase Structure Grammar*, 151–98. Stanford: CSLI Publications.
- Selkirk, Elizabeth. 1995. Sentence prosody: Intonation, stress, and phrasing. In J. A. Goldsmith (ed.), *The Handbook of Phonological Theory*, 550–569. London: Basil Blackwell.
- Yatabe, Shûichi. 1996. Long-distance scrambling via partial compaction. In M. Koizumi and M. Oishi and U. Sauerland (eds.), *Formal Approaches to Japanese Linguistics 2* (MIT Working Papers in Linguistics 29). Cambridge, MA, 303–317.
- Yatabe, Shûichi. 2001. The syntax and semantics of left-node raising in Japanese. In D. Flickinger and A. Kathol (ed.), *Proceedings of the 7th International HPSG Conference*, 325–344.

Sign language generation in an ALE HPSG

Ian Marshall

University of East Anglia

Eva Safar

University of East Anglia

Proceedings of the 11th International Conference on
Head-Driven Phrase Structure Grammar

Center for Computational Linguistics, Katholieke Universiteit Leuven

Stefan Müller (Editor)

2004

Stanford, CA: CSLI Publications

pages 189–201

Marshall, Ian & Eva Safar. 2004. Sign language generation in an ALE HPSG.
In Stefan Müller (ed.), *Proceedings of the 11th International Conference on Head-Driven Phrase Structure Grammar*, Center for Computational Linguistics, Katholieke Universiteit Leuven, 189–201. Stanford, CA: CSLI Publications. DOI: 10.21248/hpsg.2004.11.



Abstract

During the past fifty years sign languages have been recognised as genuine languages with their own syntax and distinctive phonology. In the case of sign languages, phonetic description characterises the manual and non-manual aspects of signing. The latter relate to facial expression and upper torso position. In the case of manual components these characterise hand shape, orientation and position, and hand/arm movement in three dimensional space around the signer's body. These phonetic characteristics can be notated as HamNoSys descriptions of signs which has an executable interpretation to drive an avatar.

The HPSG sign language generation component of a text to sign language system prototype is described. The assimilation of SL morphological features to generate signs which respect positional agreement in signing space are emphasised.

1 Introduction

A prototype English text to sign language (SL) translation system has been developed¹. English text is analysed into a Discourse Representation Structure Representation (DRS). The DRS is transformed into HPSG sem components as input to an ALE based SL generation component for British Sign Language (BSL) The Hamburg Notation System (HamNoSys)[Prillwitz et al. (1989); Hanke and Schmalting (2001); Hanke (2002)] provides the SL phonetic description which is subsequently input to a 'virtual human' avatar (Figure 1)²[Kennaway (2001)].

A constraint based lexicalist framework of HPSG [Pollard and Sag (1994); Ginzburg and Sag (2000)] is appropriate as sign order in SLs is largely lexically determined: verbs and adjectives typically determine whether their complements precede or succeed them. In addition the uniform representation of phonetic, syntactic and semantic information facilitates constraining of a complex though determinate information flow between lexical items and sign space representation for determining morphological constituents.

2 A Brief Characterisation of Sign Language Phenomena

This discussion concentrates upon the use of HPSG for generation of the manual components of signing in British Sign Language (BSL). In particular, we note the following phenomena [Brien (1992); Sutton-Spence and Woll (1999)]

1. some nominals can be signed at specific positions in signing space and these locations then have syntactic significance

¹This work was initiated within *ViSiCAST*, an EU Framework V supported project which builds on work supported by the UK Independent Television Commission and Post Office. The project develops virtual signing technology in order to provide information access and services to Deaf people.

²The avatar illustrated was developed by Televirtual, Norwich within *ViSiCAST*.



Figure 1: Avatar sign realisation

2. nominals which cannot be located in this way can be positioned in signing space by indexing a particular location after the sign
3. nominals can be referred to anaphorically by inclusion of classifier handshapes within manipulator verbs
4. directional verbs must be syntactically consistent with the locations of their subject and object
5. verbs exhibits syntactic agreement for number with their arguments.

In addition, particular positions in signing space (see Figure 2) can be populated by more than one object or person though typically these can be distinguished by different classifier handshapes. The sentence *I take the mug.* is glossed as

MUG (px) TAKE (px, p1, manip_handshape (MUG)) I (p1)

where the original position of the 'mug' and 'I' must agree with the start and end positions of the sign for 'TAKE'. The fully instantiated generated HamNoSys phonetic form for this sentence is:

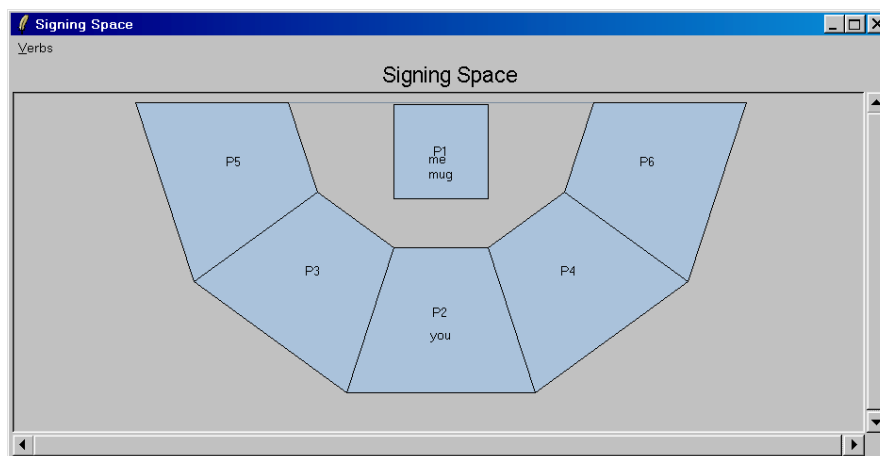

Figure 2: Signing Space Positions

```
[ [ mug ],
  [ non_raised ],
  [ hamfist, hamthumbacrossmod, hamextfingerol,
    hampalml, hamshoulders, hamclose, hamparbegin,
    hammoveu, hamarcu, hamsmallmod, hamreplace,
    hamextfingerul, hampalmdl, hamparend ] ],
[ [ take ],
  [ non_raised ],
  [ hamceeall, hamextfingeror, hambetween,
    hamextfingerr, hampalml, hamshoulders, hamlrat,
    hamarmextended, hamreplace, hamextfingeror,
    hambetween, hamextfingerr, hampalml, hamchest,
    hamclose ] ],
[ [ me ],
  [ non_raised ],
  [ hamfinger2, hamthumbacrossmod, hamextfingeril,
    hampalmr, hamchest, hamtouch ] ]
```

3 The Feature Structure

The HPSG feature structure was designed for parallel development of lexicons for a number of different national sign languages³. To account for the SL phenomena above SL constituents are subclassified as *sentence*, *sent*, *phrase*, *word* and *leer* (German 'empty' denoting dropped items). *Word* is the feature structure for an in-

³Colleagues at the University of Hamburg designed the initial structure, subsequently revised to accommodate a number of refinements as work progressed.

dividual sign, and is subclassified as *verb*, *noun* and *adjective*. *Verb* is subclassified to distinguish *fixed*, *directional* (parameterised by start/end positions), *manipulative* (parameterised by a proform classifier handshake). Combinations of these types are permitted, for example 'take' is a *dir(ectional)manip(ulative)* verb. *Adj* is subclassified to indicate whether an adjective requires pre or post complements. *Noun* is subclassified as *person*, *object* or *location*, each of the former two may be either invariant or locatable in signing space. Each constituent has a relatively standard division of SEM, SYN and PHON features, and in addition a (English textual) GLOSS.

The most significant deviations from more standard HPSG grammars are the complexity of the phonetic component and the use of a CONTEXT feature within SYN.

4 The Lexicon and Grammar Rules

[[take], [Brow], [teIk, Nhd, Hsh, Efd, Plm, Const, Heightobj,
Distobj, R1, hamreplace, Efd, Plm, Heightsubj, Distsubj, R2]] \implies

word	
gloss	take
phon	see Fig 4
syn	see Fig 5
sem	see Fig 6

Figure 3: take's LHS

Figures 3, 4, 5, 6, 7, and 8 illustrate a typical lexical entry for 'take'. The lexicon exhibits the most significant adaptation of ALE to accommodate the BSL grammar. The standard ALE implementation calls the predicate 'gen' which, for a successful derivation, returns a sequence of words in one of its arguments. The ALE implementation has been modified so that this result is a list of sign phonetic descriptions, each element of which is a 3 tuple of sign gloss, non-manual and manual descriptions determined by the left hand side of a lexical items (Figure 3). The non-manual and manual descriptions are each lists of HamNoSys sign 'phonemes'. Thus, the structuring of the PHON feature duplicates information collated in the LHS of lexical items. The flattened phonetical non-manual and manual lists are determined locally by the lexical item (rather than by a post generation tree walk). However, as variables in the LHS of lexical items cannot be referenced non-locally in grammar rules, the PHON feature functions as a 'scratch area' via which non-local bindings and constraints are established.

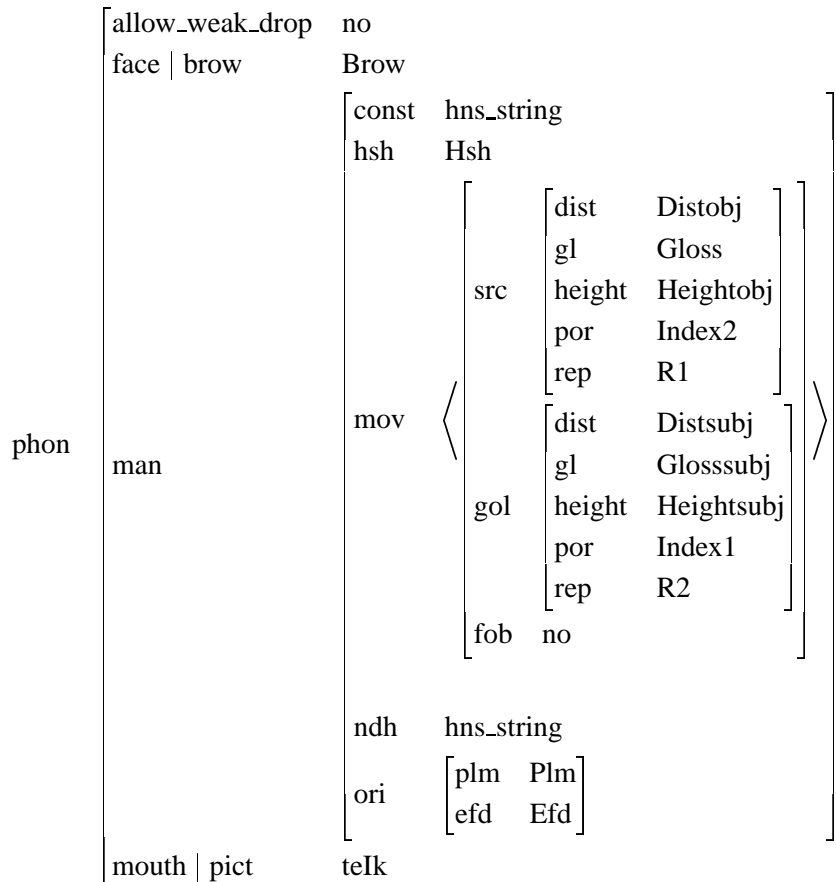

Figure 4: take's Phon

The SYN component contains features which determine sentence mode, pluralisation, (pro)noun drop and placement (anaphoric reference in signing space). In addition the usual interpretations of pre- and post- complements governs grammar rule selection and thus determines aspects of sign order.

Sentence MODE is propagated throughout a HPSG structure for a sentence by associating sentence type (declarative, yes-no question, wh-question) with eye BROW position (normal, raised, furrowed) in PHON and propagating this throughout all mother, head daughter (sem_head) and daughter (cat) nodes in both chain and non-chain rules. Currently this is overly simplistic as eye brow position is significant at the ends of questions (rather than throughout the entire proposition).

Anaphoric relationships are achieved by reference to positions within signing space. Nominals can be located at specific positions (either by being signed at that location if they are not fixed signs or by pointing). Subsequently, these positions can be used to refer to the nominal. In the case of directional verbs, such positions

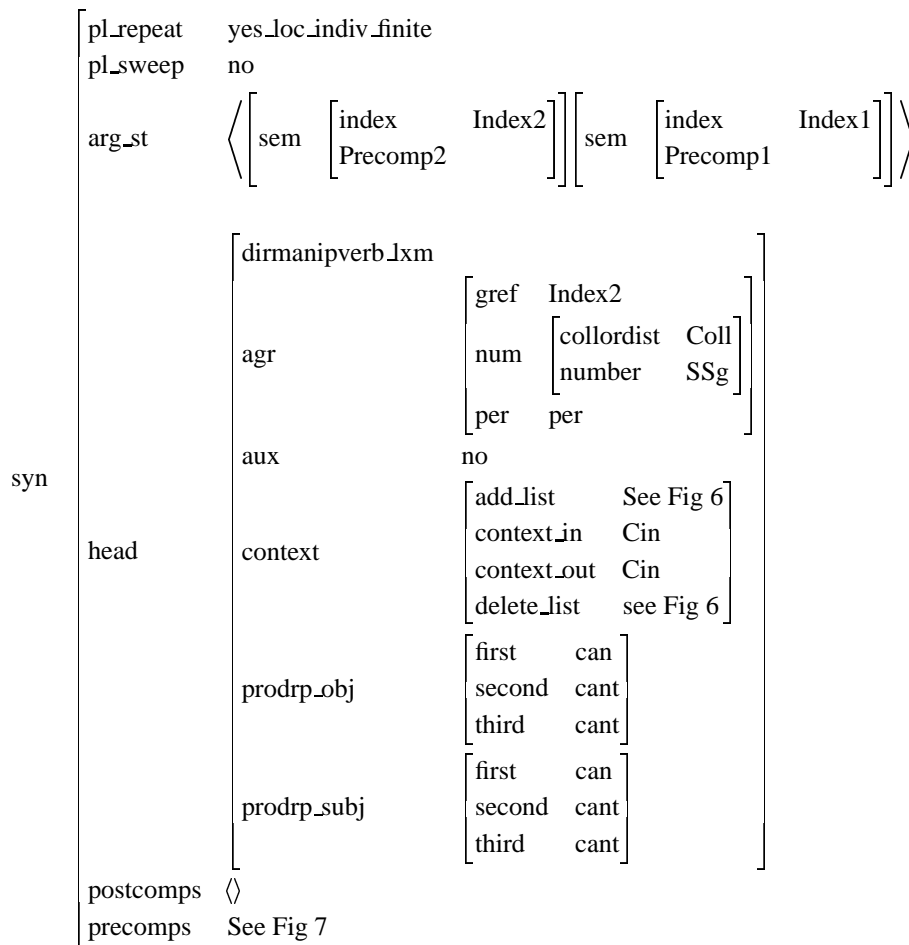

Figure 5: take's Syn

are obligatory morphemes of the sign and must agree with the appropriate position of the sign. Such agreement is achieved by propagating a map of sign space positions (phonemes for pointing, moving towards and moving to each location) through a derivation in the SYN:HEAD:CONTEXT feature. CONTEXT_IN is the current state of signing space which at the start of the derivation indicates positions of 'I' and 'you' and other non-allocated available positions. Nominals which are referred to anaphorically and those which are arguments of directional verbs of movement have to be registered within signing space. This is achieved by associating planning system style ADD_LIST and DELETE_LIST features with verbs and propositions. The ADD_LIST is an ordered sequence of registrations which are instantiated to indexical information associated with its nominal arguments and are used to register the start and end positions. The DELETE_LIST is used with directional verbs of movement in order to model movement of an object or person to the

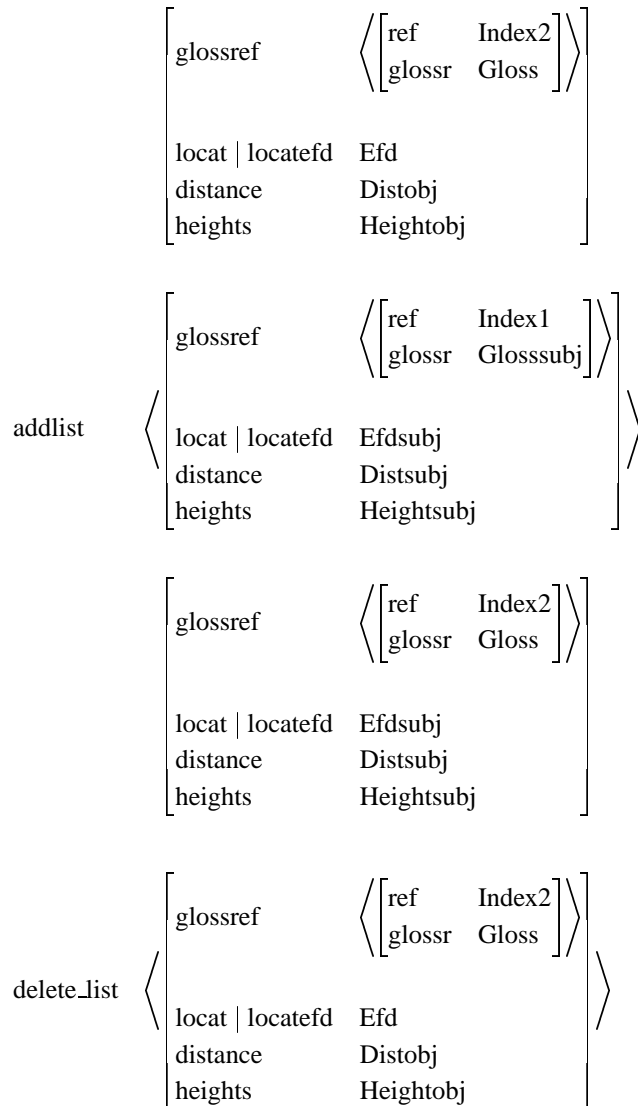

Figure 6: take's add and delete lists

destination location. The CONTEXT_OUT feature records the result of such registrations in order that an up-to-date model of signing space is propagated through a derivation.

The values Hsh, Const, Plm and Efd in the LHS of the rule (Figure 3) which determine the handshape are propagated from the classifier features associated with PreComp2 in SYN:PRECOMPS (Figure 7). Precomp2 is instantiated to the feature structure of the nominal, and hence its classifier proforms.

ALE's head-driven generation algorithm [Carpenter and Penn (1999)] is appropriate as the modelled BSL constructions are analysed as consisting of an identifi-

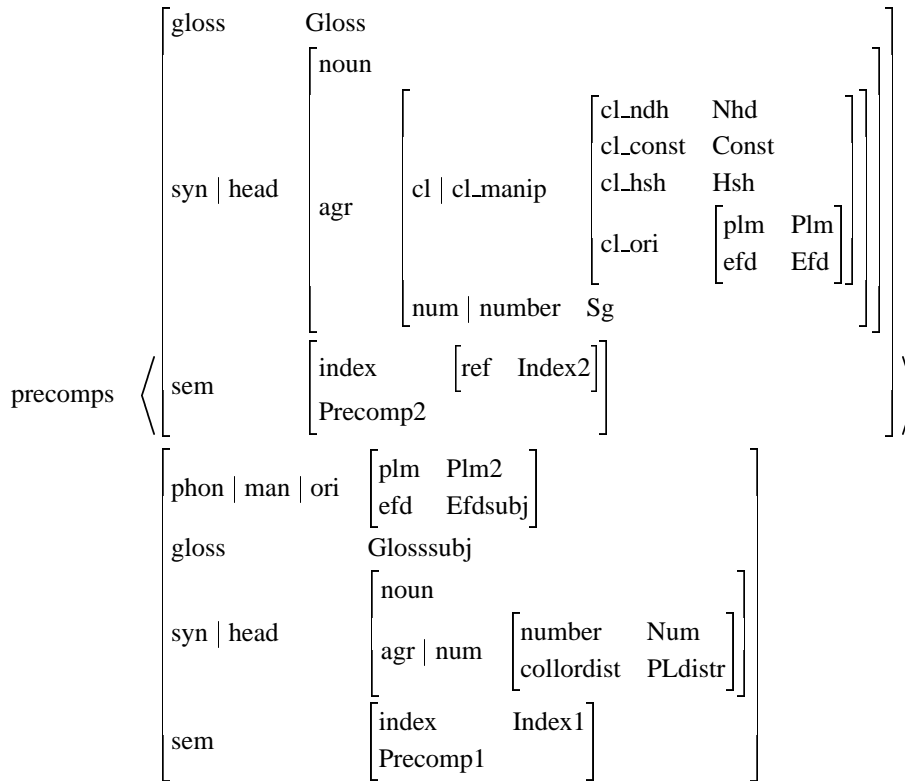

Figure 7: take's pre complements

able head-daughter. A nested SEM structure is derived from the DRS representation and an initial allocation map for SYN:HEAD:CONTEXT:CONTEXT_IN are used to initiate generation. The *semantics* predicate propagates both the SEM and CONTEXT_IN component of SYN when non-chain rules are used. Bottom-up chain rules have a conventional form as illustrated in Figure 9.

The CONTEXT_IN feature contains the available allocation map positions and reflects the state of occupied and free positions at a given stage of generation. The following illustrates a single position using HamNoSys mnemonics for the second person singular location (glossed as YOU).

```
syn:head:context:context_in:
  [(glossref: [(glossr:you, ref:Ind1)],
    halfway_mov: [hammoveo],
    locat: (locatplm: [hampalm1],
      locatefd: [hamextfingero]),
    distance: [hamarmextended],
    heights: [hamchest]),
    ...]
```

The movement of the sign towards this position is an outward movement from

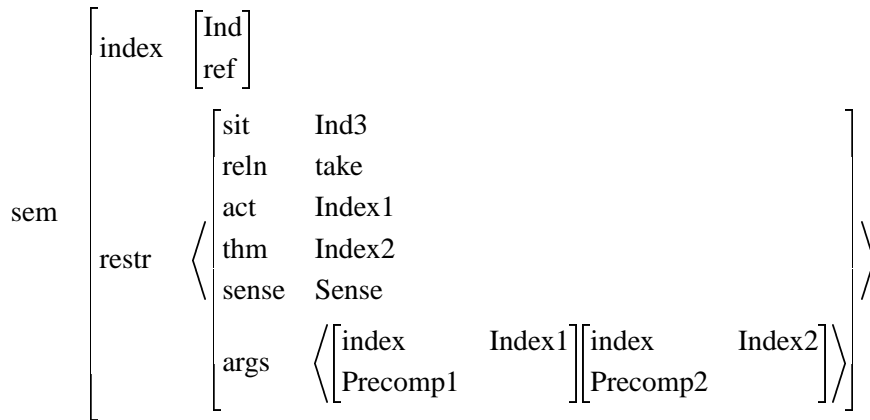

Figure 8: take's Sem

the body (hammoveo), the orientation of the palm is to the left (hampalm), extended finger direction is outward (hamextfingero). The position of the hand relative to the body is chest level (hamchest) at an extended arm distance (hamarmextended). Currently the allocation map consists of five such positions all at chest level. This needs to be extended further to include locations at differing heights to allow for locating of objects at naturally occurring locations.

The propagation of CONTEXT_IN and CONTEXT_OUT are governed by allocation map propagation principles (Figures 10, 11 and 12). Principle 1 requires that verbs and propositions propagate (unmodified) the CONTEXT_IN value to CONTEXT_OUT. As head daughters, verbs and prepositions are responsible for registering the objects/persons in their complements in signing space. Principle 3 applies for their final complements, however addition (\oplus) is addition without replication (if the object is already located in signing space then the allocated position is used). Many verbs have empty delete lists, but directional verbs of movement specify removal (\ominus) of the starting location and the add list determines the new destination location. The rule for non-final complements (Principle 2) requires the add and delete lists to be inherited by the mother node.

The ordering of head-daughter followed by daughter supports proposition-final subject pronouns. Procedural attachment of the pro_drop principle allows such a pronoun to be optionally deleted due to 'take's PRODRP.SUBJ:FIRST feature. Such deletion requires that the non-head daughter is derived as an explicit pronoun (recorded in Syn) modified (as Syni) to generate its pronominal features even though its LHS lexical realisation is empty (see Figure 9). If two ALE cat> daughters are generated to achieve this then both lexical LHSs would appear in the resulting sign sequence. Hence derivation of the pronominal form is achieved by a recursive call to ALE ('gen').

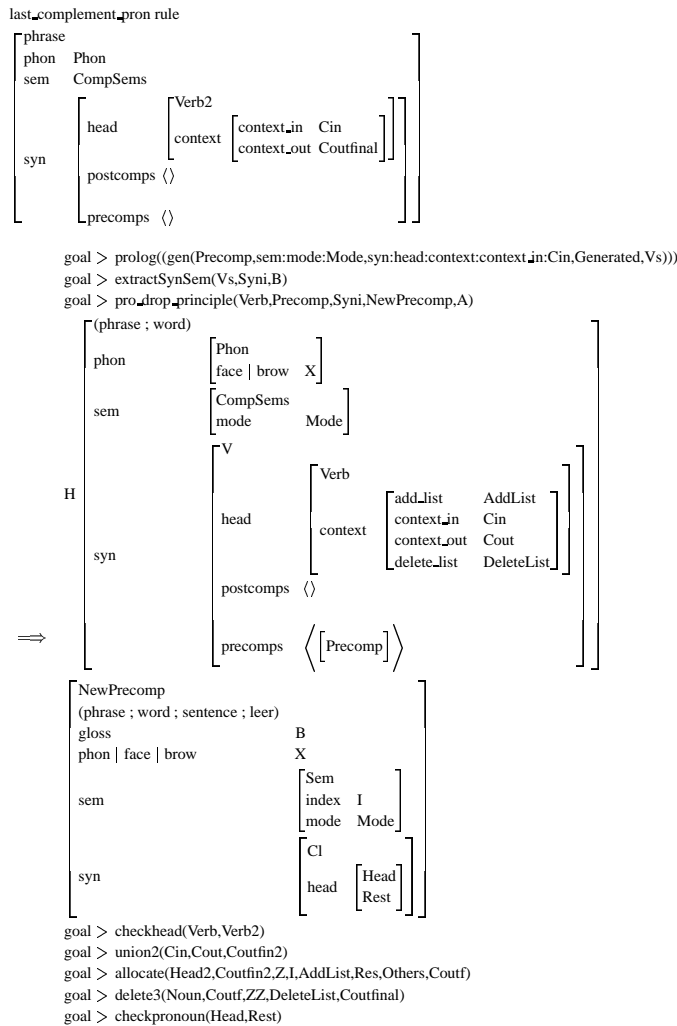

Figure 9: Last Complement Pronoun Rule

5 Conclusions

In passing we propose a comparison with the following English sentences:

1. I held the foot of the ladder on which John stood as he passed the book down/?up to me.
2. Leslie went to London where he had a gender change operation but now ?she/?he has returned to Newcastle.

The former involves semantic relationships which must be invoked to explain the anomalous reading which is sign language would be inherent in the placement of the ladder, book and individuals. In English it is difficult to manufacture examples where syntactic agreement dynamically alters mid sentence, but as we illustrate above this phenomena is not uncommon in sign language.

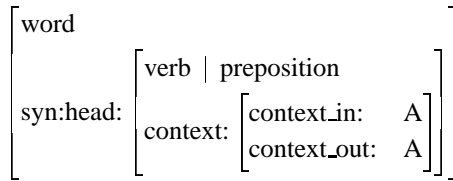

Figure 10: Principle 1 : Allocation Map - Default Lexical Propagation

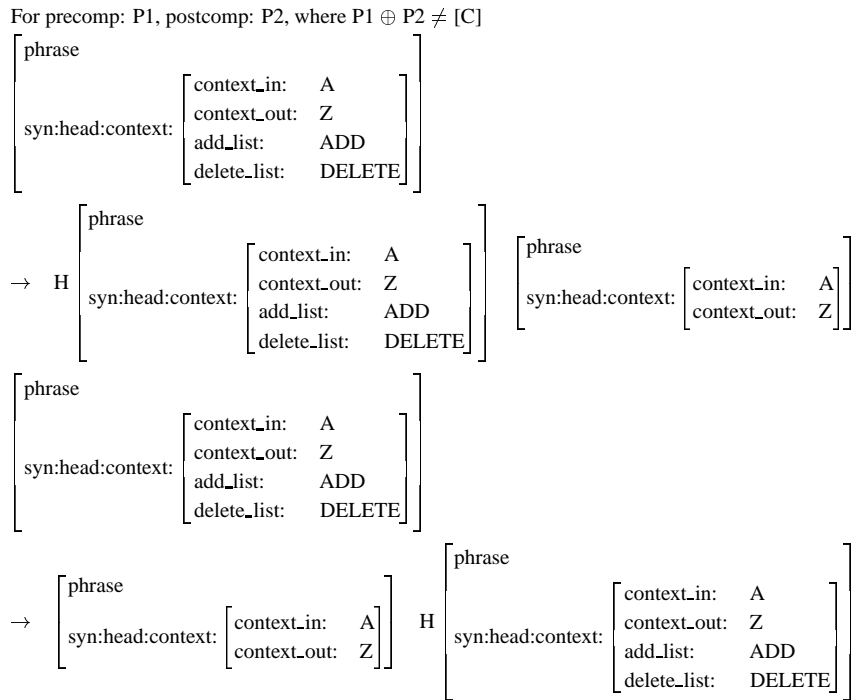

Figure 11: Principle 2 : Allocation Map - Default Phrasal Propagation Principles

References

- Brien, D. (Ed.). 1992. *Dictionary of British Sign Language/English*. London, Boston: Faber and Faber.
- Carpenter, B. and Penn, G. 1999. *The Attribute Logic Engine. User's Guide. Version 3.2 Beta*. Bell Labs.
- Ginzburg, J. and Sag, I.A. 2000. *Interrogative Investigations - The Form, Meaning, and Use of English Interrogatives..* Stanford, California: CSLI Publications.
- Hanke, T. 2002. HamNoSys in a sign language generation context. In R. Schulmeister and H. Reinitzer (eds.), *Progress in sign language research. (In honor of Siegmund Prillwitz)*, International Studies on Sign Language and Communication of the Deaf; 40, pages pp. 249–264, Hamburg.

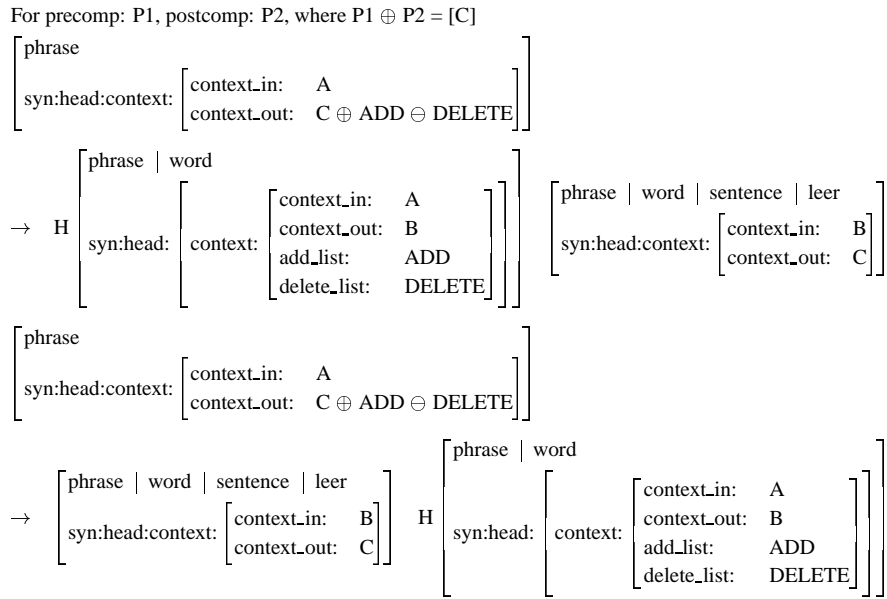

Figure 12: Principle 3: Allocation Map - Last Complement Propagation Principles

Hanke, T. and Schmalting, C. 2001. A HamNoSys-based phonetic transcription system as a basis for sign language generation. In *Gesture Workshop 2001*, London.

Kennaway, J.R. 2001. Synthetic Animation of Deaf Signing Gestures. In *The Fourth International Workshop on Gesture and Sign Language Interaction, Gesture Workshop 2001 (GW2001)*, City University, London, UK.

Pollard, C. and Sag, I.A. 1994. *Head-Driven Phrase Structure Grammar*. Chicago: The University of Chicago Press.

Prillwitz, S., Leven, R., Zienert, H., Hanke, T., Henning, J. et al. 1989. *Hamburg Notation System for Sign Languages - An Introductory Guide*. Institute of German Sign Language and Communication of the Deaf, University of Hamburg: International Studies on Sign Language and the Communication of the Deaf, Volume 5.

Sutton-Spence, R. and Woll, B. 1999. *The Linguistics of British Sign Language. An Introduction*. Cambridge: University Press.

An analysis of depictive secondary predicates in German without discontinuous constituents

Stefan Müller 

Universität Bremen

Proceedings of the 11th International Conference on
Head-Driven Phrase Structure Grammar

Center for Computational Linguistics, Katholieke Universiteit Leuven

Stefan Müller (Editor)

2004

Stanford, CA: CSLI Publications

pages 202–222

Keywords: depictives, secondary predication, HPSG, syntax, German

Müller, Stefan. 2004. An analysis of depictive secondary predicates in German without discontinuous constituents. In Stefan Müller (ed.), *Proceedings of the 11th International Conference on Head-Driven Phrase Structure Grammar*, Center for Computational Linguistics, Katholieke Universiteit Leuven, 202–222. Stanford, CA: CSLI Publications. DOI: 10.21248/hpsg.2004.12. 

Abstract

In Müller, To Appear 2005b I provide evidence that suggests that linearization approaches that analyze German clause structure with discontinuous constituents cannot account for the German clause structure in an insightful way. In order to eliminate the very powerful concept of linearization domains and discontinuous constituents from the grammar, analyses of other phenomena which also rely on discontinuous constituents should therefore be revised.

In this paper, I develop an analysis of German depictive secondary predicates that differs from the one suggested in Müller, 2002 by assuming binary branching structures, verb movement, and continuous constituents instead of a linearization approach. Some shortcomings of previous analyses are pointed out and it is shown how linearization constraints regarding depictive predicate and antecedent can be modeled.

1 Introduction

This paper deals with depictive secondary predicates, examples of which are given in (1):

- (1) a. Er ißt das Fleisch_i roh_i.
he eats the meat raw
b. Er_i ißt das Fleisch nackt_i.
he eats the meat naked

In German, uninflected adjectives and prepositional phrases may appear as depictive predicates, as the examples in (1) and (2) show.

- (2) Ich habe ihn (gestern) im dunklen Anzug getroffen.¹
I have him yesterday in.the dark suit met
'I met him in a dark suit yesterday.'

Depictives say something about a state that holds for a participant of an event during the event.

Depictives pattern with adjuncts in terms of Focus Projection (Winkler, 1997, p. 310) and linearization in the so-called Mittelfeld (Müller, 2002, Chapter 4.1.4).

To establish the predication relation between the depictive predicate and its antecedent, I suggested a coindexing analysis, in which the subject of the depictive is coindexed with an element of the argument structure of the modified verb. Since the depictive is not necessarily adjacent to the verb and since the argument structure is usually not projected, I suggested an analysis that makes use of discontinuous constituents.

[†]I want to thank two anonymous reviewers of HPSG 2004 for comments on an earlier version of this paper. I also thank all participants of HPSG 2004 and in particular Berthold Crysmann and Tibor Kiss for discussion.

¹See Helbig and Buscha, 1972, p. 556 for a similar example.

Considering new data with multiple constituents in front of the finite verb, I developed an analysis of German clause structure which makes discontinuous constituents superfluous for accounting for verb placement and constituent serialization (Müller, To Appear 2005a, Müller, To Appear 2005b).

In the following paper I develop an analysis of depictive secondary predicates that does not require discontinuous constituents, but nevertheless uses binary branching structures and that fits into the general fragment of German that is outlined in Müller, To Appear 2005a.

The paper is structured as follows: In Section 2 I discuss the phenomenon of depictive secondary predicates in more detail. I show that reference to non-overt antecedents (Section 2.1) and oblique antecedents (Section 2.2) is possible. The reference to non-arguments (Section 2.3) and to elements inside of arguments (Section 2.4) is excluded. In Section 2.5 I discuss linearization of depictive secondary predicates with regard to their antecedents. In Section 3, I discuss previous analyses and their problems. Section 4 gives a brief introduction to basic assumptions regarding the analysis of clause structure in the framework of HPSG and Section 5 provides the analysis of depictive secondary predication.

2 The Phenomenon

2.1 Non-Overt Antecedents

(3) shows that reference to unexpressed subjects is possible:²

- (3) a. daß das Buch nackt gelesen wurde³
 that the book naked read was
 ‘that the book was read naked’
- b. daß das Buch nackt zu lesen ist
 that the book naked to read is
 ‘The book is to be read naked.’

Example (3a) is a passive construction and in (3b) we have a modal infinitive.

Zifonun (1997, p. 1803) gives the following example and claims that the depictive predicate cannot refer to the logical subject of the passivized verb.⁴

- (4) Die Äpfel wurden ungewaschen in den Keller getragen.
 the apples were unwashed in the basement carried
 ‘The apples were carried to the basement unwashed.’

²See also Paul, 1919, p. 51, Plank, 1985, p. 175, Jacobs, 1994, p. 297, Grewendorf (1989, p. 129; 1993, p. 1313) Haider, 1997, p. 6 and Müller, 1999, p. 320 for examples for predication over non-overt antecedents in German and Baker, 1988, p. 318 for English examples.

³See Müller, 2002, p. 177 for a similar example.

⁴Jaeggli (1986, p. 614)—following Chomsky (1986, p. 121)—makes a similar claim for English. As the translations of the examples in (3) show, this claim is as wrong for English as it is for German.

Chomsky claims that only a syntactically present element can be the subject of adjectival predication. This includes PRO but excludes predication over passive subjects.

That the reading in which the depictive refers to the agent of the carrying is hardly available is probably due to a preference rule that makes readings where a depictive refers to an non-overt antecedent dispreferred. If the reading in which the depictive refers to the logical object of the main verb is semantically implausible, the reference to the logical subject of the main verb is fine as the examples in (3) show.

Reference to non-overt logical subjects is also possible with intransitive verbs:

- (5) a. Auf dem Land fahren alle betrunken.
 on the country drive all drunk
 ‘Everyone drives drunk in the country.’
 b. Auf dem Land wird auch betrunken gefahren.
 on the country is also drunk driven
 ‘There is also driving drunk in the country.’

According to Bresnan (1982, p. 416–417) similar examples in Icelandic and Norwegian are ungrammatical. Bresnan derives this from a theory that predicts that the passivization of intransitive verbs whose subject functionally controls a predicate complement is impossible. The HPSG equivalent of functional control is sharing of SYNSEM values, i.e., sharing of syntactic information like case and of semantic information. To account for (5) Bresnan had to assume that the relation between German state predicates and their antecedents is anaphoric control rather than functional control as in Icelandic and Norwegian. The HPSG equivalent of anaphoric control is sharing of referential indices. Alternatively, she could assume that state predicates are not complements in German. In Section 5, I will develop a coindexing-analysis that assumes depictives to be adjuncts.

Depictive predicates can also refer to the non-expressed subject of an adjectival participle:

- (6) die [_N’ [_{AP} nackt schlafende] Frau]
 the naked sleeping woman
 ‘the woman who is sleeping naked’

In (6) *Frau* is coreferent with the syntactic and the logical subject of *schlafende*. *Frau* is not syntactically realized in a projection of the deverbal adjective.

Grewendorf (1989, p. 129; 1993, p. 1313) and Haider (1997, p. 6) discuss the examples in (7a) and (7b), respectively.

- (7) a. Der Doktor untersucht _ nur nüchtern.
 the doctor examines only sober
 b. Dieser Arzt_i untersucht (Patienten_j) nur unbekleidet_{i/j}.
 this doctor examines patients only undressed

Grewendorf assumes the non-overt subject of *nüchtern* to be the empty pronominal element *pro*. Haider (1997, p. 28) assumes that depictive predicates are generated adjacent to the DP they predicate over. Therefore he is forced to assume some

empty referential element in cases like (7b)⁵ and also in passive examples like (3). However, in GB-theory it is usually assumed that the passive participle does not assign a theta role to its logical subject (Chomsky, 1993, p. 124). Grewendorf (1993, p. 1311) assumes that the subject of impersonal passives as in (5) is an expletive *pro*. Haider (1993, p. 134) assumes that there is no subject in impersonal passive constructions. So, irrespective of the particular approach to passive, there is no element, overt or non-overt, that bears the theta role of the logical subject and that could function as an antecedent of a depictive.

2.2 Reference to Oblique Antecedents

The examples in (1) show that depictives may refer to subjects and to accusative objects. In this subsection I want to discuss the possibility of depictives to refer to more oblique elements.

Haider (1985, p. 94) observes that the predication over a dative object in (8b) is marked in comparison to predication over accusative objects. In (8a) both reference to the subject and to the accusative object is possible, while the reading with reference to the object is hardly available in (8b).

- (8) a. Er_i sah sie_j nackt $_{i/j}$.
 he_{nom} saw her_{acc} naked
 b. Er_i half ihr_j nackt $_{i/??j}$.
 he_{nom} helped her_{dat} naked

Haider concludes that depictive predicates can refer to NPs with structural case only. According to Haider, only nominative and accusative are structurally assigned cases in verbal environments while dative is not. As Haider notes, this could be explained easily by the assumption that the subject of the predicate and the NP it refers to are identical. The fact that in German, NP subjects always have structural case explains why a depictive element cannot refer to a dative NP, because dative is taken to be a lexical case.

Wunderlich (1997, p. 131) develops an analysis for depictives that posits two different subanalyses: one for depictives that refer to the subject (VP-adjuncts), and another one for depictives that refer to the direct object (V-adjuncts). Datives (including dative objects of verbs like *helfen*) are assumed to be indirect objects. Therefore he predicts that reference to dative NPs is not possible. Kaufmann and Wunderlich (1998, p. 9) claim that the predication of depictive and resultative predicates over indirect objects is excluded in all languages.

While these statements refer to syntactic case, similar claims can be found with regard to semantic roles. Discussing (9), Rothstein (1985, p. 85) assumes a restriction that allows depictives in English to refer to agents and patients, but not to goals.

⁵In Haider, 1993, p. 180, he assumes that the omitted argument in (7) is treated as an implicit argument and not as an empty, pronominal element. This is the view that I adopt in the following.

- (9) The nurse_i gave John_j the medicine sick_{i/*j}.

A similar claim is made by Koch and Rosengren (1995, p. 80), who claim that only reference to agent or theme is allowed.⁶ That the reference to thematic roles is not suited for the explanation of the possible antecedents was noted by Koizumi (1994, p. 46–48). His examples are given in (10a, b). Simpson (In Preparation) provides the additional example in (10c):

- (10) a. They gave the patients_j the drugs drunk_{*j}.
b. The patients_j were given the drugs drunk_j.
c. After being given the drugs drunk_j, the patients_j complained.

That the exclusion of reference to datives is not a hard constraint is shown by examples like (11):

- (11) Man_i half ihm_j erst halbtot_{i/j}.⁷
one_{nom} helped him_{dat} only half.dead
'One helped him only half dead.'

In (11) the context favors the reading with reference to the dative object: Since it is implausible that half dead people help others, the subject is not a plausible antecedent candidate in (11). In general, it can be said that the reference to dative NPs improves considerably if the reference to the nominative is excluded by world knowledge (Plank, 1985, p. 175).

The reference to the dative in (8b) improves, if we passivize the sentence: In (12) the reference to the dative NP is considerably better than in (8b), where another candidate for coreference appears at the surface.

- (12) Ihr_j wurde nackt_{i/j} geholfen.
her_{dat} was naked helped
'She was helped naked.'

Of course, the sentence in (12) has a reading where the helper is naked. This reading is indicated by the *i*-index at *nackt*, which does not appear anywhere else in the sentence.

Simpson (In Preparation) notes that changing the polarity and modality to force a generic conditional interpretation improves reference to recipient/goal arguments. Her English example can be translated to German:

- (13) Du kannst ihnen bewußtlos keine Spritzen geben.
you_{nom} can them_{dat} unconscious no injections_{acc} give
'You can't give them injections unconscious.'

⁶On page 4 they make this claim with reference to grammatical functions, i. e. subject and direct object.

⁷Plank, 1985, p. 175.

From the data presented above it must be concluded that both the restriction on the case of possible antecedent phrases and the restriction on the thematic role of the antecedent phrase are not adequate. In what follows, I will therefore assume that the subject of the depictive predicate is coindexed, i. e. coreferent with, the antecedent phrase. I do not assume that the subject of the depictive and the antecedent are identical, as was suggested by Haider.

2.3 Reference to Non-Arguments

NPs in adjuncts are excluded from the list of possible referents of depictives as (14) shows.

- (14) a. weil Karl_i [neben Maria_j] nackt_{i/*j} schlief.
because Karl next Maria naked slept
‘because Karl slept next to Maria naked.’
- b. weil [neben Maria_j] nackt_{i/*j} geschlafen wurde.
because next Maria naked slept was
Intended: ‘because somebody slept next to Maria while she was naked.’

Even passivizing the sentence as in (14b) does not improve the reference to an element inside of the adjunct.

2.4 Reference to Elements inside of Arguments

The reference to NPs that are internal to other NPs is also excluded, as is demonstrated by (15):⁸

- (15) a. daß Jan [den Freund von Maria_i] nackt_{*i} traf.
that Jan the friend of Maria naked met
‘that Jan met the (male) friend of Maria naked.’
- b. daß Jan [Marias_i Vater] nackt_{*i} traf.
that Jan Maria’s father naked met
‘that Jan met Maria’s father naked.’
- c. * daß Jan [Maria nackt und ihren Freund] traf.
that Jan Maria naked and her friend met
Intended: ‘that Jan met Maria naked together with her friend.’

2.5 Linearization of Depictives with Regard to Their Antecedents

As Lötscher (1985, p. 208) pointed out, the antecedent of the depictive predicate has to precede the depictive:

⁸Neeleman (1994, p. 157) gives Dutch examples that are equivalent to those in (15a,b).

- (16) a. weil er_i die Äpfel $_j$ ungewaschen $_{i/j}$ ißt.
 because he the apples unwashed eats
 ‘because he eats the apples unwashed.’
 (He is unwashed or the apples are unwashed.)
- b. weil er_i ungewaschen $_{i/*j}$ die Äpfel $_j$ ißt.
 because he unwashed the apples eats
 ‘because he eats the apples unwashed.’
 (He is unwashed.)
- c. * weil ungewaschen $_{*i/*j}$ er_i / der Mann $_i$ die Äpfel $_j$ ißt.
 because unwashed he the man the apples eats

In example (16a) the adjective may refer to either *er* or to *die Äpfel*. In (16b) the reference to *die Äpfel* is excluded. Only the reading in which *ungewaschen* refers to *er* is available. The example (16c) in which the depictive precedes both of the possible antecedents is ungrammatical.

There are examples like (17) that do not follow this pattern, but these are instances of so-called I-topicalization (Jacobs, 1997), which can also be observed with parts of the predicate complex that usually have a fixed position, and which therefore should be analyzed similar to extraction.

- (17) weil betrunken $_i$ niemand $_i$ hereinkommt.⁹
 because drunk nobody $_{nom}$ in.comes
 ‘because nobody gets in drunk.’

See also Haider (1997, p. 29–30), who suggests a special treatment of sentences in which the depictive precedes the subject.

I will not deal with sentences like (17) here.

2.6 Summary of the Data Discussion

The reference to subjects, direct objects, and indirect objects is possible. Therefore a raising analysis that identifies the subject of the depictive predicate with its antecedent is not adequate since the subject has structural case and dative objects bear lexical case. A coindexing analysis on the other hand is compatible with the data.

Reference to non-overt elements is possible and reference to adjuncts or elements embedded in arguments is not possible. So an analysis is needed that coindexes the subject of the depictive with one argument of the modified verb.

Finally, it was noted that the antecedent has to precede the depictive predicate.

3 Previous Analyses and Analysis Options

In this part of the paper I want to discuss analyses that were suggested or that seem to be options. In Section 3.1 it is shown that a direct coindexation of elements

⁹von Stechow and Sternefeld, 1988, p. 466.

of the argument structure with the subject of the depictive predicate is not possible if binary branching structures without projection of the argument structure are assumed. I will then explore alternatives.

3.1 Projection of the Argument Structure

Kaufmann (1995, p. 87–88) noted that accounts with binary branching structures have problems with examples like (18), if the argument structure is not projected.

- (18) weil er nackt der Frau hilft.
 because he naked the woman helps
 ‘because he helps the woman naked.’

The analysis of (18) is shown in Figure 1. In what follows I assume a version of

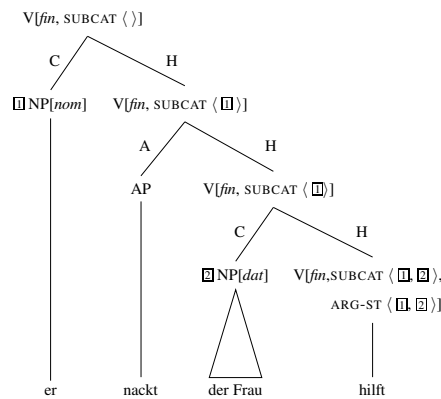

Figure 1: The Problem of Accessibility of the Argument Structure

Head-Driven Phrase Structure Grammar (Pollard and Sag, 1994) as the underlying framework. ARG-ST is a list that contains all arguments of a head. The SUBCAT list differs from ARG-ST in that arguments that are combined with their head are not represented at the SUBCAT list of the mother node.

The combination of *der Frau* and *hilft* in Figure 1 is phrasal and therefore does not have an ARG-ST that could be used to establish the coindexing, since ARG-ST usually is a feature which is appropriate for lexical items only.

The problem of an approach that projects the argument structure is that it becomes possible to select internal properties of phrases, since all information about the valence of a head becomes available at the maximal projection of the head. This basically enables non-local selection which should be impossible in principle (see Pollard and Sag, 1994, p. 23 on the locality of selection).

In the following I discuss alternatives where a projection of the argument structure is not necessary.

3.2 Flat Structures

A possible solution to the problem of accessibility of the argument structure could be the assumption of a flat structure for the German clause as was suggested for instance by Uszkoreit (1987) in the framework of GPSG and by Pollard (1996) and Kasper (1994) in the framework of HPSG. In order to account for adjuncts in such an analysis, Kasper assumed complex relational constraints that traverse the daughters of the flat structure and compute the meaning of a clause. The relational constraint that is needed for this is quite complex and an analysis that can do without such machinery would be the preferred one. See also Müller, 2004 for discussion.

While the need for relational constraints is not an empirical argument against flat structures, the examples in (19) are:¹⁰ Usually only one constituent can appear in front of the finite verb in German. However there are examples like (19) that seem to be exceptions to this rule:

- (19) a. [Alle Träume] [gleichzeitig] lassen sich nur selten verwirklichen.¹¹
all dreams simultaneously let self only rarely realize
'All dreams can seldom be realized at once.'
- b. [Dauerhaft] [mehr Arbeitsplätze] gebe es erst, wenn sich eine
lasting more jobs give_{conj} it only when self a
Wachstumsrate von mindestens 2,5 Prozent über einen Zeitraum von
growth.rate from at.least 2.5 percent over a period from
drei oder vier Jahren halten lasse.¹²
three or four years hold let
'A long-term fall in unemployment can only be expected if a growth rate of at least 2.5 percent can be maintained over a period of three or four years.'
- c. [Los] [damit] geht es schon am 15. April.¹³
PART there.with goes it already at 15 April
'It already starts at 15th of April.'

The position in front of the finite verb can be filled by various combinations of elements. Adjuncts, arguments, and predicate complex forming constituents can appear there. These constituents are linearized as if they were part of the German Mittelfeld, right sentence bracket or Nachfeld: The normal linearization of the examples in (19a,b) is shown in (20):

- (20) a. daß sich nur selten alle Träume gleichzeitig verwirklichen lassen
that self only seldom all dreams simultaneously realize let

¹⁰See Müller, 2003 for an extensive documentation of this phenomenon.

¹¹Brochure from Berliner Sparkasse, 1/1999

¹²taz, 19.04.2000, p. 5

¹³taz, 01.03.2002, p. 8.

- b. weil es dauerhaft mehr Arbeitsplätze erst gebe, wenn
because it lasting more jobs only give if

If the elements are reordered the result gets marked:

- (21) a. ?* weil sich nur selten gleichzeitig alle Träume
because self only seldom simultaneously all dreams
verwirklichen lassen.
realize let
- b. ?* weil es mehr Arbeitsplätze dauerhaft erst gebe, wenn
because it more jobs lasting only give if

As was pointed out by Susan Olsen (p. c. 2001), the same is true for the ordering of elements in front of the finite verb: If they are serialized in an order that does violate the constraints that can be observed for constituents in the Mittelfeld, the sentences get marked (see also Eisenberg, 1994, S. 412–413).

- (22) a. ?* Gleichzeitig alle Träume lassen sich nur selten verwirklichen.
simultaneously all dreams let self only seldom realize
- b. ?* Mehr Arbeitsplätze dauerhaft gebe es erst, wenn
more jobs lasting give it only if

The particle in (19c) and (23) occupies the right sentence bracket. The pronominal adverb in (19c) is extraposed, the usual position would be some position in the Mittelfeld as shown in (23):

- (23) daß es (damit) schon am 15. April (damit) losgeht

The data in (19)–(23) can only be accounted for if one assumes that the constituents in front of the finite verb are part of a verbal projection. For more evidence see Müller, 2003. In verb movement approaches to verb initial sentences a trace is assumed in the right sentence bracket. The very same empty element can be used to account for the verbal properties of the material in front of the finite verb in sentences like (19): The V2 property of German can be maintained and the linearization properties of the elements in multiple frontings are explained (Müller, To Appear 2005b).

Flat accounts cannot account for sentences like (19) without stipulation, since there is nothing that would license a verbal projection in front of the finite verb.

3.3 Adjuncts as Complements

Van Noord and Bouma (1994) and Bouma et al. (2001) suggested a lexical treatment of adjuncts: Adjuncts are introduced into valence lists by lexical rules or relational constraints. If this analysis is applied to depictives, depictives are introduced lexically and therefore a coindexation with one element of the argument structure is possible. Such a lexical analysis of depictives as lexically introduced V-adjuncts is suggested by Wunderlich (1997).

As Levine (2003) noted, adjuncts-as-complements analyses have problems in getting scope facts in coordinated structures right in which an adjunct scopes over several coordinated verbs. Instead of allowing for a reading where the adjunct scopes over a conjoined event, only scope over events belonging to the respective verbs is predicted since adjuncts are introduced as dependents of a single verb.

The scope problem found by Levine also extends to depictives, as the following example by Andrew McIntyre shows:

- (24) The professor drove to the university, held a lecture and met with his doctoral students stoned (the whole time).

The depictive scopes over all three events, i.e., over *drove*, *held*, and *met*. Similarly in (25) a reading has to be possible, where the person who set the table and who did the dishes was naked the whole time.

- (25) weil er nackt den Tisch gedeckt und abgewaschen hat
because he naked the table set and the.dishes.done has
'because he set the table and did the dishes naked.'

3.4 Binding Theory

The data discussed so far could be analyzed parallel to what was suggested by Pollard and Sag (1994, Chapter 6.8.3) for control: The subject of a controlled VP like in (26a) is assumed to be a reflexive pronoun, which has to be bound in its binding domain, i.e., to an element that is less oblique than the controlled VP.^{14,15}

- (26) a. John promised Bill to leave.
b. promise: ARG-ST $\langle NP_i (, NP), VP[\text{SUBJ } \langle NP:refl_i \rangle] \rangle$

In order to make such an analysis work, one has to assume that depictives are members of the list that is relevant for binding. Nowadays this is the ARG-ST list. However, if the depictive is part of the ARG-ST list and as such is mapped to the valence list, we get the coordination problem that was mentioned above.

3.5 Discontinuous Constituents and Modification of (Quasi) Lexical Elements

In Müller, 2002, Chapter 4, I suggest an analysis that assumes that depictives attach to (quasi) lexical elements. They can either attach to lexical verbs or to verbal complexes, which are treated as lexical units. For examples like (18) on page 8 He assumes a discontinuous constituent consisting of adjunct and verb. The analysis is shown in figure 2 on the next page. Since *nackt* is combined directly with *hilft*,

¹⁴(26b) was taken from Pollard and Sag, 1994, p. 303 and adapted to the notation used in more recent HPSG publications.

¹⁵Note that binding accounts that rely on c-command have problems with non-overt subjects in passive constructions, since even if empty elements are assumed as subjects, they do not bear a theta role. For Binding Theories like the one by Pollard and Sag (1994), which operates on argument structure, non-overt antecedents are no problem.

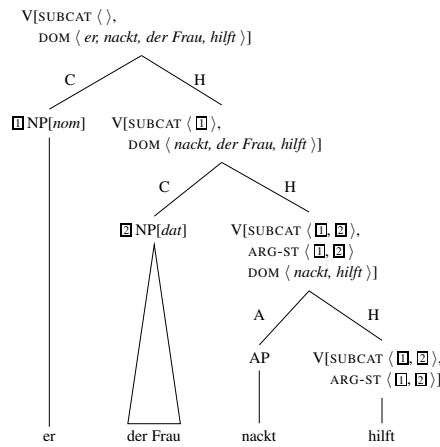

Figure 2: Binary Branching Structures and Depictive Predicates (Discontinuous)

reference to the argument structure is possible. *nackt* is inserted into the constituent order domain of its head *hilft*. See Müller, 2002, p. 28 for the constraints on domain formation that I assume. After combining these two elements the resulting projection is combined with the dative object and with the subject. The dative object *der Frau* is inserted into the domain between *nackt* and *hilft*.

Since it is possible to have more than one depictive predicate per clause, ARG-ST has to be present at the node dominating *nackt* and *hilft*. In the treatment of adjuncts suggested in Müller, 2002, adjunction did not change the lexical/phrasal status of elements. The result of adjunction to lexical elements resulted in (quasi) lexical elements.

As mentioned in the introduction, the linearization approach has problems with multiple fronting data like (19). It is possible to account for the data by using an empty verbal head, but this would be a stipulation of an entity not needed elsewhere in the grammar.

In addition my earlier approach has problems in accounting for the linearization facts, discussed in Section 2.5. The problem is discussed in more detail in the following subsection.

3.6 Linearization Rules

In Müller, 2002, p. 202 I suggested the following linearization rule, which was supposed to model the fact that the antecedent has to precede the depictive predicate in the local linearization domain:

$$(27) \text{ COMP } XP_{\boxed{1}} < \text{ AP/PP}[\text{SUBJ } \langle \text{NP}_{\boxed{2}} \rangle] \wedge \boxed{1} == \boxed{2}$$

This rule accounts for the markedness/unacceptability of sentences in which an XP that is coindexed with the subject of the predicate follows the predicate.

The rule correctly excludes the coindexing of *er* or *die Äpfel* with the subject of *ungewaschen* in (28).

- (28) * weil ungewaschen_{*i/*j} er_i / der Mann_i die Äpfel_j ißt.
 because unwashed he the man the apples eats

Unfortunately it also excludes the coindexation of the subject of *nackt* with the reflexive in (29):

- (29) weil sie_i nackt_i sich_i selbst sah.
 because she naked her self saw
 ‘because she saw herself naked.’

Since the linearization rule is violated, the sentence should be ungrammatical or at least marked, which it is not. The purpose of the rule is to regulate the order of *sie* and *nackt* in (29). That the *sich* is also coindexed with the subject of *nackt* is due to the fact that *sie* is coindexed with the subject of *nackt* and *sich* is coindexed with *sie*. This coindexation of personal pronoun and reflexive results in a situation in which the linearization rule in (27) makes wrong predictions.

It could be argued that depictives should not refer to reflexives in the first place, since sentences like (30) are not ambiguous.

- (30) weil sie sich nackt sah.
 because she herself naked saw
 ‘because she saw herself naked.’

If reference to reflexives is admitted, we get two analyses for (30): one in which the depictive is coindexed with the reflexive and another one in which it is coindexed with the personal pronoun. However, such analyses may not be ruled out by a general ban on coindexing with reflexives, since sentences like (31) are possible:

- (31) weil der König sich nackt rasieren ließ
 because the king himself naked shave let
 ‘because the king let somebody shave him naked.’

(31) has a reading in which *nackt* scopes over *rasieren*. *rasieren* has two arguments: the one referring to the one who does the shaving and the one who is shaved. In order to get the preferred reading, *nackt* has to predicate over the reflexive, which fills the argument slot of the shaved person.

After the discussion of shortcomings of earlier proposals, I now turn to the analysis. Before I come to the analysis of depictives in Section 5, I want to discuss some basic assumptions I make for the analysis of the German clause structure in the next section.

4 Basic Assumptions about the German Clause Structure

Following the tradition in Transformational Grammar and proposals by Bach and Fourquet (Fourquet, 1957; Bierwisch, 1963, p. 34; Bach, 1962; Reis, 1974; Thiersch, 1978, Chapter 1), I assume that German is a verb final language and that verb

initial sentences are related to verb final ones. I assume that there is a verbal trace in the position that would be occupied by the finite verb in verb last sentences and that this trace is bound by a verb in initial position. For details of the implementation see (Kiss, 1995a; Meurers, 2000, p. 206–208). A discussion of verb movement can also be found in Frank, 1994. One reason for assuming such a verb movement analysis as opposed to flat structures or linearization approaches are cases of multiple frontings like those in (19). As is argued in Müller, To Appear 2005b, these sentences are best analyzed with an empty verbal head in front of the finite verb. The empty verbal head is the same empty element that is used in verb movement analyses and the lexical rule that licenses it is parallel to the verb movement lexical rule used by Kiss (1995a) and others modulo verbal complex formation.

As is well known, constituents can be ordered rather freely in German. For instance, both orders of arguments are possible in sentences like (32):

- (32) a. weil ein Mann dem Kind hilft.
 because a man the child helps
 ‘because a man helps the child.’
 b. weil dem Kind ein Mann hilft
 because the child a man helps

I assume an approach to scrambling that is similar to approaches that assumed a SUBCAT set (Gunji, 1986; Hinrichs and Nakazawa, 1989; Pollard, 1996). Instead of assuming a set, I assume a SUBCAT list and a relational constraint that deletes the argument daughter from the SUBCAT list of the head daughter when two elements are combined with the head argument schema:¹⁶

Schema 1 (Head Argument Schema)

head-argument-structure →

$$\left[\begin{array}{l} \text{SYNSEM} \quad \left[\text{LOC|CAT|SUBCAT del}(\boxed{2}, \boxed{1}) \right] \\ \text{HEAD-DTR} \quad \left[\text{SYNSEM|LOC|CAT|SUBCAT } \boxed{1} \right] \\ \text{NON-HEAD-DTRS} \quad \left\langle \left[\text{SYNSEM } \boxed{2} \right] \right\rangle \end{array} \right]$$

The reader who is interested in the interaction with verbal complex formation, the details of the verb movement analysis, and a discussion of alternative proposals is referred to Müller, To Appear 2005a.

5 The Analysis of German Depictive Secondary Predicates

As was shown in Section 2.5, the antecedent has to precede the depictive secondary predicate. This is accounted for straightforwardly in the theory outlined in the last

¹⁶See also Frank and Reyle, 1992, p. 185 and Kiss (1995b, p. 218–223) for a similar treatment of constituent order.

section, if we assume that the subject of the depictive predicate is coindexed with an element in the SUBCAT list of the verbal head it combines with. For the examples in (16) we get the structures in (33):

- (33) a. weil [er [die Äpfel [ungewaschen ißt]]].
 because he the apples unwashed eats
 ‘because he eats the apples unwashed.’
 (He is unwashed or the apples are unwashed.)
- b. weil [er [ungewaschen [die Äpfel ißt]]].
 because he unwashed the apples eats
 ‘because he eats the apples unwashed.’
 (He is unwashed.)
- c. * weil [ungewaschen [er / der Mann [die Äpfel ißt]]].
 because unwashed he the man the apples eats

In (33a) the depictive is directly combined with the verb and the SUBCAT list of *ißt* contains both the subject and the object. Therefore the account predicts that both elements are antecedent candidates for *ungewaschen*.

In (33b) the adjective is combined with a projection of *ißt* that contains the object of *ißt*. Therefore the object is not an element of the SUBCAT list of this projection and only the subject is a possible antecedent of *ungewaschen*.

In the last case *der Mann die Äpfel ißt* is fully saturated. The SUBCAT list of this projection is empty. Since there is no possible antecedent for the depictive, the sentence is rejected by the grammar.

Since I assume that verb initial sentences involve a verbal trace at the position that the finite verb would occupy in verb final sentences, verb initial sentences with depictives can be analyzed in parallel to their verb last counterparts:

- (34) Ißt_i [er [die Äpfel [ungewaschen _j]]]?
 eats he the apples unwashed
 ‘Does he eat the apples unwashed?’
 (He is unwashed or the apples are unwashed.)

Since both the subject and the object are elements of the SUBCAT list of the verbal trace, both are antecedent candidates of the depictive adjective.

Note that approaches like the ones suggested by Kiss and Wesche (1991, p. 225), Schmidt et al. (1996), and Crysmann (2003), which assume a left branching analysis for (some) verb initial sentences are incompatible with such an analysis, since they would rule out (34). (34) would have the structure in (35):

- (35) [[[Ißt er] die Äpfel] ungewaschen]?
 eats he the apples unwashed

Since the SUBCAT list of *Ißt er die Äpfel* is the empty list, there would not be any antecedent candidate for *ungewaschen* in the SUBCAT list of this projection.

Before I discuss the lexical rule for depictive secondary predicates that is the core of the analysis, I want to come back to the possibility to refer to non-overt

antecedents, which was discussed in Section 2.1. Example (3a) shows that depictive secondary predicates may predicate over subjects that are not realized at the surface. In approaches that use blocking/deblocking techniques to account for the perfect and the passive with a single lexical item for the second participle (Haider, 1986; Heinz and Matiasek, 1994), such data is unproblematic. In the lexical item for *gegessen* the subject is blocked. It can be deblocked by the perfect auxiliary as in (36a) or it can remain blocked as in the passive example in (36b):

- (36) a. Er hat den Apfel gegessen.
 he has the appel eaten
 b. Der Apfel wurde gegessen.
 the appel was eaten

In HPSG grammars of German such blocked elements are usually represented as the value of a feature like *DA* (for designated argument) or *SUBJ* (for subject). Since the subject is contained in the lexical item of the participle, it is possible for the depictive to access it: Depictive secondary predicates can refer to an element of a list that is a concatenation of the *SUBJ* list and the *SUBCAT* list of the verbal element they modify. Following Pollard (1996) and Kiss (1995a), I assume that the *SUBJ* list of finite verbs is the empty list, since the subject of a finite verb is listed as an element of *SUBCAT*. So the extension that allows depictives to refer to elements of *SUBJ* is only relevant for non-finite verbs and for participles.

The lexical rule in (37) maps a predicative element onto an adjunct that can modify a verbal element. The *SUBJ* and the *SUBCAT* list of the modified element (③ and ④) are appended by the relational constraint *append* (\oplus) and the *member* relation chooses nondeterministically one of the elements from the list that results from the *append* relation. The chosen element is coindexed with the subject of the input predicate (①).

The semantics of the input predicate (②) and the semantics of the modified head (⑤) are combined in the semantic representation of the output of the lexical rule.

In Müller, 2002, Chapter 4.1.1.2, I show that the obliqueness hierarchy plays a role in accounting for the different markedness of antecedent choices. So sentences with a depictive predicate that predicates over a dative argument are more marked than those where the predicate predicates over an accusative object or a subject. This can be captured in the current approach with reference to semantic obliqueness. Since the semantic contribution of the modified verbal element is accessible (⑤) the relative semantic obliqueness of the antecedent can be determined.

6 Other Languages

This analysis of German depictives works very well and it does not rely on the projection of the argument structure. However, languages with more rigid constituent order cannot be analyzed with respect to the saturatedness of projections to which

(37) Lexical Rule that maps predicative elements onto depictive predicates:

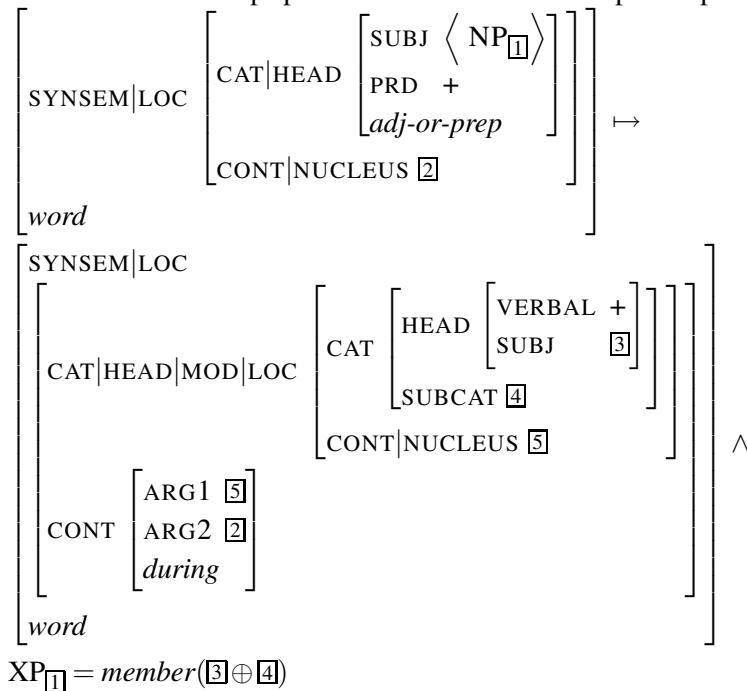

depictives attach. An example for such a language is English. Sentences like (38) are usually analyzed so that the depictive adjoins to the VP:

(38) He [[eats the fish] raw].

This means that the antecedent of *raw* is not contained in the valence list of *eats* when the depictive is combined with the verbal projection. To account for the English data only three options remain: 1) Binding Theory, 2) Adjuncts as Complements, 3) projecting the Argument Structure. Since 1) needs 2) to work properly and since 2) yields scope problems, 3) seems to be the only option left for dealing with depictives in English. There seem to be other phenomena in grammar that make the projection of argument structure necessary. For example, Kiss, 2001 suggests an analysis of quantifier scope that relies on the projection of the argument structure.

One could claim that depictives universally are analyzed with reference to the argument structure and that the linearization rules for German in addition refer to the saturatedness of verbal projections.

7 Conclusion

I developed an analysis of depictive secondary predicates that does not rely on discontinuous constituents. Since discontinuous constituents are a very powerful

device, an approach that can avoid them is favorable.

The analysis does not refer to the argument structure of heads and therefore it is not necessary to assume flat structures, a lexical introduction of adjuncts, or a projection of the argument structure.

The analysis can explain why antecedents have to precede the depictive predicates without referring to linear precedence rules, which are difficult to formalize, since coindexing of arguments is involved and reflexives may interfere.

References

- Bach, Emmon. 1962. The Order of Elements in a Transformational Grammar of German. *Language* 8(3), 263–269.
- Baker, Mark C. 1988. *Incorporation. A Theory of Grammatical Function Change*. Chicago, London: University of Chicago Press.
- Bierwisch, Manfred. 1963. *Grammatik des deutschen Verbs*. studia grammatica II, Berlin: Akademie Verlag.
- Bouma, Gosse, Malouf, Rob and Sag, Ivan. 2001. Satisfying Constraints on Extraction and Adjunction. *Natural Language and Linguistic Theory* 19(1), 1–65.
- Bresnan, Joan. 1982. Control and Complementation. *Linguistic Inquiry* 13(3), 343–434.
- Chomsky, Noam. 1986. *Knowledge of Language – Its Nature, Origin, and Use*. Convergence, New York, Westport: Connecticut, London: Praeger.
- Chomsky, Noam. 1993. *Lectures on Government and Binding*. Berlin, New York: Mouton de Gruyter, 7. edition.
- Cipollone, Domenic. 2001. Morphologically Complex Predicates in Japanese and What They Tell us about Grammar Architecture. OSU Working Papers in Linguistics 56, Ohio State University.
- Crysmann, Berthold. 2003. On the Efficient Implementation of German Verb Placement in HPSG. In *Proceedings of RANLP 2003*, pages 112–116, Borovets, Bulgaria.
- Eisenberg, Peter. 1994. *Grundriß der deutschen Grammatik*. Stuttgart, Weimar: Verlag J. B. Metzler, third edition.
- Fourquet, Jean. 1957. Review of: Heinz Anstock: *Deutsche Syntax – Lehr und Übungsbuch*. *Wirkendes Wort* 8, 120–122.
- Frank, Anette. 1994. Verb Second by Lexical Rule or by Underspecification. Arbeitspapiere des SFB 340 No. 43, IBM Deutschland GmbH, Heidelberg.
- Frank, Anette and Reyle, Uwe. 1992. How to Cope With Scrambling and Scope. In Günther Görz (ed.), *Konvens 92. 1. Konferenz „Verarbeitung natürlicher Sprache“*. Nürnberg 7.–9. Oktober 1992, Informatik aktuell, pages 178–187, Berlin, Heidelberg, New York: Springer-Verlag.
- Grewendorf, Günther. 1989. *Ergativity in German*. Studies in Generative Grammar, No. 35, Dordrecht: Holland, Providence: U.S.A.: Foris Publications.
- Grewendorf, Günther. 1993. German. A Grammatical Sketch. In Joachim Jacobs, Arnim von Stechow, Wolfgang Sterenfeld and Theo Vennemann (eds.), *Syntax – Ein internationales Handbuch zeitgenössischer Forschung*, volume 9.2 of *Handbücher zur Sprach- und Kommunikationswissenschaft*, pages 1288–1319, Berlin: Walter de Gruyter Verlag.
- Gunji, Takao. 1986. Subcategorization and Word Order. In William J. Poser (ed.), *Papers from the Second International Workshop on Japanese Syntax*, pages 1–21, Stanford: CSLI Publications.
- Haider, Hubert. 1985. The Case of German. In Jindřich Toman (ed.), *Studies in German*

- Grammar*, Studies in Generative Grammar, No. 21, pages 23–64, Dordrecht: Holland, Cinnaminson: U.S.A.: Foris Publications.
- Haider, Hubert. 1986. Fehlende Argumente: vom Passiv zu kohärenten Infinitiven. *Linguistische Berichte* 101, 3–33.
- Haider, Hubert. 1993. *Deutsche Syntax – generativ. Vorstudien zur Theorie einer projektiven Grammatik*. Tübingen: Gunter Narr Verlag.
- Haider, Hubert. 1997. Precedence among Predicates. *The Journal of Comparative Germanic Linguistics* 1, 2–41.
- Heinz, Wolfgang and Matiasek, Johannes. 1994. Argument Structure and Case Assignment in German. In John Nerbonne, Klaus Netter and Carl J. Pollard (eds.), *German in Head-Driven Phrase Structure Grammar*, pages 199–236, Stanford: CSLI Publications.
- Helbig, Gerhard and Buscha, Joachim. 1972. *Deutsche Grammatik. Ein Handbuch für den Ausländerunterricht*. Leipzig: VEB Verlag Enzyklopädie.
- Hinrichs, Erhard W. and Nakazawa, Tsuneko. 1989. Subcategorization and VP Structure in German. In *Aspects of German VP Structure*, Sfs-Report-01-93, Eberhard-Karls-Universität Tübingen.
- Jacobs, Joachim. 1994. Das lexikalische Fundament der Unterscheidung von obligatorischen und fakultativen Ergänzungen. *Zeitschrift für Germanistische Linguistik* 22, 284–319.
- Jacobs, Joachim. 1997. I-Topikalisierung. *Linguistische Berichte* 168, 91–134.
- Jaeggli, Osvaldo A. 1986. Passive. *Linguistic Inquiry* 17(4), 587–622.
- Kasper, Robert T. 1994. Adjuncts in the Mittelfeld. In John Nerbonne, Klaus Netter and Carl J. Pollard (eds.), *German in Head-Driven Phrase Structure Grammar*, pages 39–70, Stanford: CSLI Publications.
- Kaufmann, Ingrid. 1995. *Konzeptuelle Grundlagen semantischer Dekompositionsstrukturen. Die Kombinatorik lokaler Verben und prädikativer Elemente*. Linguistische Arbeiten, No. 335, Tübingen: Max Niemeyer Verlag.
- Kaufmann, Ingrid and Wunderlich, Dieter. 1998. Cross-linguistic Patterns of Resultatives. SFB 282: Theorie des Lexikons 109, Heinrich Heine Uni/BUGH, Düsseldorf.
- Kiss, Tibor. 1995a. *Infinite Komplementation. Neue Studien zum deutschen Verbum infinitum*. Linguistische Arbeiten, No. 333, Tübingen: Max Niemeyer Verlag.
- Kiss, Tibor. 1995b. *Merkmale und Repräsentationen*. Opladen/Wiesbaden: Westdeutscher Verlag.
- Kiss, Tibor. 2001. Configurational and Relational Scope Determination in German. In Walt Detmar Meurers and Tibor Kiss (eds.), *Constraint-Based Approaches to Germanic Syntax*, pages 141–175, Stanford: CSLI.
- Kiss, Tibor and Wesche, Birgit. 1991. Verb Order and Head Movement. In O. Herzog and C.-R. Rollinger (eds.), *Text Understanding in LILOG*, pages 216–242, Springer-Verlag.
- Koch, Wolfgang and Rosengren, Inger. 1995. Secondary Predications: Their Grammatical and Conceptual Structure. Forschungsprogramm Sprache und Pragmatik 35, Germanistisches Institut der Universität Lund, Lund.
- Koizumi, Masatoshi. 1994. Secondary Predicates. *Journal of East Asian Linguistics* 3, 25–29.
- Levine, Robert D. 2003. Adjunct Valents, Cumulative Scopings and Impossible Descriptions. In Jongbok Kim and Stephen Wechsler (eds.), *The Proceedings of the 9th International Conference on Head-Driven Phrase Structure Grammar*, pages 209–232, Stanford, CA: CSLI Publications, <http://csli-publications.stanford.edu/HPSG/3/>.
- Lötscher, Andreas. 1985. Syntaktische Bedingungen der Topikalisierung. *Deutsche Sprache* 13, 207–229.

- Meurers, Detmar. 2000. Lexical Generalizations in the Syntax of German Non-Finite Constructions. Arbeitspapiere des SFB 340 No. 145, Eberhard-Karls-Universität, Tübingen.
- Müller, Stefan. 1999. *Deutsche Syntax deklarativ. Head-Driven Phrase Structure Grammar für das Deutsche*. Linguistische Arbeiten, No. 394, Tübingen: Max Niemeyer Verlag.
- Müller, Stefan. 2002. *Complex Predicates: Verbal Complexes, Resultative Constructions, and Particle Verbs in German*. Stanford: CSLI.
- Müller, Stefan. 2003. Mehrfache Vorfeldbesetzung. *Deutsche Sprache* 31(1), 29–62.
- Müller, Stefan. 2004. Continuous or Discontinuous Constituents? A Comparison between Syntactic Analyses for Constituent Order and Their Processing Systems. *Research on Language and Computation* 2(2), 209–257.
- Müller, Stefan. To Appear 2005a. Zur Analyse der deutschen Satzstruktur. *Linguistische Berichte* <http://www.cl.uni-bremen.de/~stefan/Pub/satz-lb.html>. 03.10.2004.
- Müller, Stefan. To Appear 2005b. Zur Analyse der scheinbar mehrfachen Vorfeldbesetzung. *Linguistische Berichte*.
- Neeleman, Ad. 1994. *Complex Predicates*. Ph. D.thesis, Onderzoeksinstituut voor Taal en Spraak (OTS), Utrecht.
- Paul, Hermann. 1919. *Deutsche Grammatik. Teil IV: Syntax*, volume 3. Halle an der Saale: Max Niemeyer Verlag, 2nd unchanged edition 1968, Tübingen: Max Niemeyer Verlag.
- Plank, Frans. 1985. Prädikativ und Koprädikativ. *Zeitschrift für Germanistische Linguistik* 13, 154–185.
- Pollard, Carl J. 1996. On Head Non-Movement. In Harry Bunt and Arthur van Horck (eds.), *Discontinuous Constituency*, pages 279–305, Berlin, New York: Mouton de Gruyter, published version of a Ms. dated January 1990.
- Pollard, Carl J. and Sag, Ivan A. 1994. *Head-Driven Phrase Structure Grammar*. University of Chicago Press.
- Reis, Marga. 1974. Syntaktische Hauptsatzprivilegien und das Problem der deutschen Wortstellung. *Zeitschrift für Germanistische Linguistik* 2(3), 299–327.
- Rothstein, Susan D. 1985. *The Syntactic Forms of Predication*. Ph. D.thesis, Bar-Ilan University, reproduced by the Indiana University Linguistics Club.
- Schmidt, Paul, Rieder, Sibylle and Theofilidis, Axel. 1996. Final Documentation of the German LS-GRAM Lingware. Deliverable DC-WP6e (German), IAI, Saarbrücken.
- Simpson, Jane. In Preparation. Depictives in English and Warlpiri. In Nikolaus P. Himmelmann and Eva Schultze-Berndt (eds.), *Secondary Predication and Adverbial Modification. Crosslinguistic Explorations in the Syntax and Semantics of Depictives*, Oxford: Oxford University Press.
- Thiersch, Craig L. 1978. *Topics in German Syntax*. Dissertation, M.I.T.
- Uszkoreit, Hans. 1987. *Word Order and Constituent Structure in German*. CSLI Lecture Notes, No. 8, Stanford: CSLI Publications.
- van Noord, Gertjan and Bouma, Gosse. 1994. The Scope of Adjuncts and the Processing of Lexical Rules. In *Proceedings of COLING 94*, pages 250–256, Kyoto Japan.
- von Stechow, Arnim and Sternefeld, Wolfgang. 1988. *Bausteine syntaktischen Wissens. Ein Lehrbuch der Generativen Grammatik*. Opladen/Wiesbaden: Westdeutscher Verlag.
- Winkler, Susanne. 1997. *Focus and Secondary Predication*. Studies in Generative Grammar, No. 43, Berlin, New York: Mouton de Gruyter.
- Wunderlich, Dieter. 1997. Argument Extension by Lexical Adjunction. *Journal of Semantics* 14(2), 95–142.
- Zifonun, Gisela. 1997. Das Passiv. In Hans-Werner Eroms, Gerhard Stickel and Gisela Zifonun (eds.), *Grammatik der deutschen Sprache*, pages 1788–1858, Berlin, New York: Walter de Gruyter.

Propositional relative clauses in German

Manfred Sailer 

Universität Göttingen

Proceedings of the 11th International Conference on
Head-Driven Phrase Structure Grammar

Center for Computational Linguistics, Katholieke Universiteit Leuven

Stefan Müller (Editor)

2004

Stanford, CA: CSLI Publications

pages 223–243

Sailer, Manfred. 2004. Propositional relative clauses in German. In Stefan Müller (ed.), *Proceedings of the 11th International Conference on Head-Driven Phrase Structure Grammar*, Center for Computational Linguistics, Katholieke Universiteit Leuven, 223–243. Stanford, CA: CSLI Publications. DOI: 10.21248/hpsg.2004.13.



Abstract

This paper discusses a special kind of syntax-semantics mismatch: a noun with a relative clause is interpreted as if it were a complement clause. An analysis in terms of *Lexical Resource Semantics* is developed which provides a uniform account for “normal” relative clauses and for the discussed type of relative clause.

1 Introduction

In this study we will discuss a largely unnoticed type of relative clause which we will call *propositional relative clause* (PRC). PRCs manifest a mismatch between syntactic structure and interpretation: syntactically they are normal relative clauses, but in the semantics an NP which is modified by a PRC is interpreted as a proposition, even though the head noun in itself does not have a propositional interpretation. The clearest cases of PRCs will come from data with idiomatic expressions, in particular with bound words. We will show that the apparent mismatch can be resolved if we adopt a system of combinatorial semantics which exploits techniques of semantic underspecification such as *Underspecified DRT* (UDRT, Frank and Reyle (1995)), *Minimal Recursion Semantics* (MRS, Copestake et al. (2003)), *Constraint Language for Lambda Structures* (CLLS, Egg and Erk (2002)), or *Lexical Resource Semantics* (LRS, Richter and Sailer (2004a)).

A bona fide example of a German PRC is given in (1). The noun *Duzfuß* is a bound word which may only occur in the expression *mit X auf dem Duzfuß stehen* (*be on informal terms with X*). In (1) the noun takes a relative clause which contains the rest of the expression.¹

- (1) um den anderen den Duzfuß ahnen zu lassen, [auf dem man
in order to the other the informal.foot suspect to let on which one
mit den Spitzenkräften steht].
with the top executives stand
'in order to make the other one suspect that one is on informal terms with the
top executives.' (from the corpora of the *Institut für Deutsche Sprache*, Mannheim)

Examples such as (1) do not occur frequently in texts and many speakers consider them as “strange” or instances of creative language use. The English translation indicates the only possible interpretation: the NP with the relative clause is interpreted as a complement clause.

[†]The reported research originated as part my work in the project *Distributional Idiosyncrasies* of the Collaborative Research Center SFB 441 at the University of Tübingen, funded by the German Research Foundation (DFG). I am grateful to Danièle Godard, Gerald Penn, Frank Richter, Jan-Philipp Soehn, Beata Trawiński and to the reviewers for comments.

¹The context for (1) is: Eine beliebte Variante ist das Bruderschafts-Dropping, bei dem man geschickt Vornamen wie Thomas, Viktor, Ioan, Otti etc. einflicht, ... ('A popular variant is the “friendship dropping” through which one drops first names such as Thomas, Viktor, ...')

We will assume the following tentative definition of a PRC constellation: A sentence with an NP which is modified by a relative clause such that (i) the sentence is ungrammatical if the relative clause is removed, and (ii) the sentence is synonymous to a sentence in which the NP with the relative clause is replaced with a complement clause with the same lexical material. This is illustrated in (2): since *Duzfuß* is a bound word, it cannot occur freely (a). We can replace the NP with a complement clause to obtain a synonymous sentence (b).

- (2) a. *um den anderen den Duzfuß ahnen zu lassen
in order to the other the informal.foot suspect to let
- b. um den anderen ahnen zu lassen, dass man mit den
in order to the other suspect to let that one with the
Spitzenkräften auf Duzfuß steht.
top executives on informal.foot stands

In this paper we will focus on Lexical Resource Semantics (LRS). We will present a simple semantic analysis of restrictive relative clauses. We will show that this analysis provides the right readings for PRC cases as well, even though in an admittedly surprising way. In the conclusion we will briefly address the conceptual properties of LRS which allow us to account for PRCs.

2 Data

2.1 Propositional Relative Clauses with Bound Words

In this section we will study the properties of PRCs in more detail. We will first have a closer look at the noun *Duzfuß* and then provide examples of PRCs with an other bound word and, in the following subsection, also with free words.

Let us first observe that the expression in (3-a) is decomposable, i.e., it is an *idiomatically combining expression* in the sense of Nunberg et al. (1994). The noun *Duzfuß* can be assigned the meaning indicated in (b).

- (3) a. mit jemandem auf (dem) Duzfuß stehen
with someone on the informal.foot stand
‘be on informal terms with someone’
- b. *Duzfuß* \mapsto informal terms

The noun *Duzfuß* is a bound word. This means that it cannot occur outside the particular expression in (3-a). In (4) we show that *Duzfuß* is even excluded in contexts which are semantically plausible given the meaning assignment in (3-b).

- (4) jemandem das Du/ *den Duzfuß anbieten
someone the you(informal)/ the informal.foot offer
‘to offer someone to switch to informal terms’

Even though the expression in (3-a) is decomposable it is less flexible than

other decomposable idiomatic expressions. In particular the noun *Duzfuß* cannot be modified (a) nor pronominalized (b):

- (5) a. Joschka steht mit dem Kanzler auf (* gutem/ intinem) Duzfuß_i.
 Joschka stands with the chancellor on good/ intimate informal.foot
 b. *... und auch Angela steht mit Schröder darauf_i/ auf ihm_i.
 and also Angela stands with Schröder there-on/ on it

Thus sentence (1) exhibits two unusual properties for the noun *Duzfuß*: First it occurs as the complement of a verb which it normally cannot combine with. Second it takes a relative clause, i.e. a syntactic adjunct, even though it cannot be semantically modified. This apparent conflict must be explained on the basis of the interpretation of the noun and the relative clause as a proposition, as illustrated in (2-b) above. It is this unusual interpretation which let us to refer to this kind of relative clauses as *Propositional Relative Clause*.

The noun *Duzfuß* is not the only bound word in German which can occur in PRC constellations. In (6) we provide an analogous example with the bound word *Garaus*. The noun *Garaus* is restricted to the expression in (a). This expression is decomposable, but the bound word cannot be modified. In (b) we give an example of a PRC occurring with this noun. Again we can reformulate the NP with the relative clause in the form of a complement clause, see (c).

- (6) a. jdm./ etwas den Garaus machen ‘kill someone/ something’
 to someone/ something the ?? make
 b. Einzig Vera Kutters ... Negativfoto der Wiener Secession bleibt als
 Only Vera Kutter’s ... picture of the Vienna Secession remains as
 Hinweis auf den Garaus, [den die Nazis der in ihren Augen
 indication of the ?? which the Nazis to the in their eyes
 ”entarteten Kunst” machten].
 “degenerated art” made
 ‘Only Vera Kutter’s ... picture of the Vienna Secession remains as an
 indication of the fact that the Nazis destroyed what to their eyes was
 “degenerated art”’²
 c. ... bleibt als Hinweis darauf, dass die Nazis der in ihren Augen
 remains as indication of the fact that the Nazis to the in their eyes
 “entarteten Kunst” den Garaus machten
 “degenerated art” the ?? made

It should be noticed that PRCs seem to be excluded with non-decomposable expressions. In (7) we show a non-decomposable expression with a bound word (*Maulaffen*). In (b) the expression occurs in a subject clause to the verb *erbosen* (*make angry*). This verb accepts NPs or clauses as subjects. In (c) we try to give a PRC construction which should have the same meaning as (b). However, the sentence is ungrammatical.

²Found by Jan-Philipp Soehn on: <http://www.taz.de/pt/2001/11/30/a0123.nf/text>.

- (7) a. Maulaffen feilhalten ‘stand gaping’
mouth.monkeys keep for sale
- b. Mich erboste, dass die Passanten Maulaffen feilhielten
me made angry that the passers-by mouth.monkeys kept for sale
‘It made me angry that the passers-by stood gaping.’
- c. *Mich erbosten die Maulaffen, die die Passanten feilhielten.
me made angry the mouth.monkeys which the passers-by kept for sale
intended meaning as in (b)

2.2 Propositional Relative Clauses with Free Words

PRCs are not restricted to bound words: if a verb semantically requires a propositional argument but is syntactically compatible with either an S or an NP, an NP with a PRC can fulfil the requirements. As illustrated in (8) the verb *bedauern* (*regret*) has these two valence options.

- (8) a. Hans bedauerte, dass er beim Spiel das Vermögen verloren hatte.
Hans regretted that he had lost the fortune at the game.
- b. Hans bedauerte den Verlust (des Vermögens)
Hans regretted the losing of the fortune

Even though an NP can occur as the syntactic complement of *bedauern* this NP must have a propositional reading. Thus, *bedauern* fulfils the requirements of a context which allows for PRCs. Indeed we can construct PRC examples:

- (9) a. Hans bedauerte das Vermögen, das er beim Spiel verloren hatte.
Hans regretted the fortune that he at the game lost had
‘Hans regretted that he had lost the fortune at the game.’
- b. *Hans bedauerte das Vermögen.
Hans regretted the fortune

As noted above PRCs are only possible with decomposable expressions. The following set of data shows that this is not only true for expressions which bound words, but it carries over to non-decomposable expressions in general. The expression in (10) is non-decomposable and consists of free words. As expected, the PRC construction (10-c) is ungrammatical.

- (10) a. den Löffel abgeben ‘die’
the spoon away.give
- b. Ich bedauerte, dass er den Löffel abgegeben hatte.
I regretted that he the spoon away.given had
‘I regretted that he had passed away.’
- c. *Ich bedauerte den Löffel, den er abgegeben hatte.
I regretted the spoon that he away.given had

2.3 Related Phenomena

2.3.1 Arguments for a “Head Internal” Analysis of Relative Clauses

Similar data have been discussed in the generative literature on relative clauses, first in Vergnaud (1974), later in Carlson (1977), and have recently gained some attention again (for example Valentina (2000)). In (11) we list data from Carlson (1977) which illustrate what he calls an *Amount Relative Clause*.

- (11) a. make headway/ progress
b. *The headway was satisfactory.
c. The headway [that Mel made] was satisfactory.

In the mentioned approaches these data were used to argue for a syntactic structure in which the head noun originates inside the relative clause and is moved out of it by some operation. Borsley (1997, nd) presents syntactic arguments against such structures for “normal” relative clauses. This would still leave the option that for some relative clauses the head noun originates inside the relative clause, for others it does not. On the other hand we do not find syntactic differences between relative clauses which semantically modify an individual and PRCs.³

In addition it is not entirely clear whether the data considered previously are PRCs. In fact there are differences between the German PRC examples and Carlson’s Amount Relatives. First, while the noun *headway* is a bound word, just like in our first examples, it can be modified:

- (12) They made tremendous headway.

Second, a relative clause to *headway* can occur with verbs which do not require a propositional argument:

- (13) I observed the headway [that they made].

An alternative account of the *headway* data would be that *headway*, just like *Verlust* (*loss*) in (8-b), can denote an object of the right semantic type to combine with the verb. Under this perspective there would be nothing particular about the data in (11), except for the fact that *headway* — being a bound word — requires the presence of the support verb *make*.

2.3.2 Reinterpretation Phenomena à la Egg (2002)

We would also like to distinguish between PRCs and other instances of syntax-semantics mismatches. Egg (2002) discusses cases of the following type.

- (14) a. Amélie played the sonata for ten days.

³For English Hulsey and Sauerland (2002) argue that whereas “normal” relative clauses can be extraposed this is impossible with relative clauses of the type in (11-c). But notice that no such restriction holds for German: the PRC in (1) is extraposed.

- b. beautiful dancer

In (a) an iterative operator must be introduced to make the VP *played the sonata* compatible with the durative adverbial *for ten days*. The NP in (b) has a reading in which the adverbial does not take scope over the entire noun but only over part of it (*person who dances beautifully*). In PRCs on the other hand the head noun is interpreted inside the relative clause and the entire NP has the meaning of a proposition. Thus, in contrast to (a) no additional semantic material is inserted, and in contrast to (b) the adjunct (i.e. the relative clause) does not modify some part of the head noun but integrates the entire semantic contribution of the noun.

With these short remarks we tried to illustrate the differences between PRCs and other kinds of adjuncts which pose problems for a compositional analysis.

3 Lexical Resource Semantics

In this section we will outline the system of *Lexical Resource Semantics* (LRS). After some general remarks in Section 3.1 we will provide those parts of LRS which are needed for our analysis. In the next section we will apply LRS to the relative clause data.

3.1 General Remarks

LRS uses techniques of *underspecified semantics* (Reyle, 1993; Bos, 1996), but the logical form of a sentence is a single, disambiguated expression of the semantic representation language. This special status of LRS between underspecification and more traditional combinatorial systems is discussed in Richter and Sailer (2004a). This paper is also the most extensive introduction to LRS. Previous LRS publications discuss scope ambiguity (Richter and Sailer, 2001; Bouma, 2003), and multiple exponence of semantic operators (Richter and Sailer, 2001, 2004b; Sailer, 2004b). Sailer (2004a) shows how LRS as a system of clausal semantics could interact with lexical semantics.

In LRS the logical form of a sentence is assumed to be an expression of some typed semantic representation language (here: Ty2 (Gallin, 1975)). Since our examples contain definite NPs we include the ι -operator in the semantic representation language. Its use and interpretation is given in (15), taken from Krifka (2004).

- (15) For each variable x of type τ and for each ϕ of type t , $\iota x(\phi)$ is an expression whose denotation is an individual a of type τ such that $\llbracket \lambda x.\phi \rrbracket(a) = 1$ if there is exactly one such individual, otherwise the denotation is undefined.

Consider the following example for illustration. In (16) we indicate the logical form associated with the definite NP *the student*. In Figure 1 we give the subexpressions which make up this logical form. We have chosen for a tree representation to make the structure of the expression clear.

Figure 1: Subexpression structure of $\iota x(\text{student}'(w, x))$

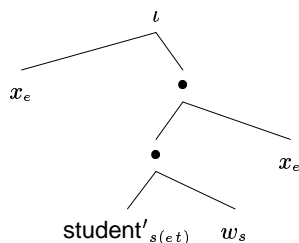
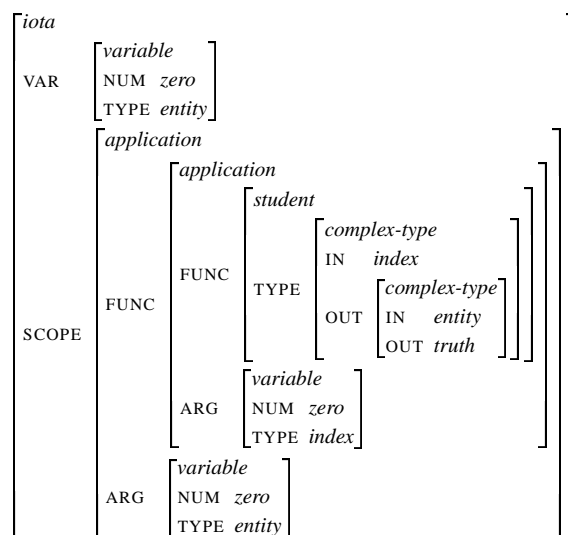

Figure 2: HPSG encoding of $\iota x(\text{student}'(w, x))$



(16) the student: $\iota x_e(\text{student}'_{s(et)}(w_s, x_e))$

Sailer (2003) explains how expressions of Ty2 can be incorporated into an HPSG grammar, as objects of the sort *meaningful-expression* (*me*). In Figure 2 we give an AVML description of a *me* object which denotes the expression in (16). For our purpose it suffices to see that all syntactic constructs of the semantic representation language are expressed in the HPSG encoding. Furthermore, the structure of the linguistic object described by the AVML in Figure 2 follows that of the expression tree in Figure 1.

In (16) the variable x occurs twice in the logical expression. Similarly the object described by the AVML in Figure 2 has several components which look alike. In HPSG components which look alike can actually be identical. This is achieved by means of *structure sharing*, (also called *token identity*) and constitutes one of the major analytical tools of the framework. The encoding of semantic expression presented in Sailer (2003) is such that all possible identities must actually be present in a linguistic object which represents such an expression. In the case at hand this would mean that the values of the paths VAR and SCOPE ARG are identical.

This discussion of identities seems to focus on a technical property of the HPSG encoding of logical expressions. It will, however, become obvious in Section 4 that this property provides the basis for our analysis of PRCs.

3.2 Brief Outline of LRS

After the general remarks on LRS and on the way expressions of a semantic representation language are integrated into an HPSG grammar, we can outline the combinatorial mechanism used in LRS. The basic intuition underlying LRS is that the logical form of a sentence is the combination of its subexpressions. These subexpressions are contributed entirely by the lexical items which make up the sentence. Consequently we specify in a sign which subexpressions it contributes to the overall logical form. In addition we have to assign some subexpressions a special status, because they play a particular role in the semantic combinatorics.

The semantic information associated with a sign is contained in the value of an attribute L(OGICAL-)F(ORM). The LF value of a sign is of sort *lrs*. This sort is defined in (17).

(17) The sort *lrs*

<i>lrs</i>	EX(TERNAL-)CONT(ENT)	<i>me</i>
	IN(TERNAL-)CONT(ENT)	<i>me</i>
	PARTS	<i>list(me)</i>

The sort *lrs* has three attributes. The PARTS list contains all subexpression which are contributed by the given sign. The other two attributes serve more technical purposes. The INCONT value is the scopally lowest subexpression contributed by the lexical head of a phrase. The EXCONT value is the expression associated with the maximal projection of the head. The EXCONT value of an utterance is the logical form of the utterance. The EXCONT value of an NP is the operator which binds the referential variable of the head noun. In the case of the NP *the student* the EXCONT value is the expression in (16).

General principles govern the relation between the values of the three attributes of an *lrs* object. For our purpose it suffices to state the INCONT PRINCIPLE, the EXCONT PRINCIPLE and parts of the SEMANTICS PRINCIPLE. We will start with the INCONT PRINCIPLE.

(18) The INCONT PRINCIPLE:

- a. In every *lrs*, the INCONT value is a subexpression of the EXCONT value.
- b. In every *lrs*, the INCONT value is an element of the PARTS list.

This principle ensures that the INCONT value of a sign is actually contributed by this sign (clause (a)) and that it will appear in the logical form associated with the maximal projection of this sign (clause (b)).

The EXCONT PRINCIPLE regulates that every expression which is contributed by a lexical item in an utterance will actually appear in the logical form, i.e. in

the EXCONT value, of this utterance. Furthermore no other semantic material is allowed. This is stated in a more technical fashion in (19).

(19) The EXCONT PRINCIPLE:

In every utterance, every subexpression of the EXCONT value of the utterance is an element of the utterance's PARTS list, and every element of the utterance's PARTS list is a subexpression of its EXCONT value.

Let us now consider an example, the NP *the red book*. This NP contains the necessary syntactic and semantic ingredients for our analysis of relative clauses: a definite determiner, an intersective modifier and a noun. In (20) we indicate the logical form associated with this NP and the corresponding LF value.⁴

(20) a. The red book: $\iota x(\text{book}'(w, x) \wedge \text{red}'(w, x))$
 b.
$$\left[\begin{array}{l} \text{EXCONT } \iota x(\text{book}'(w, x) \wedge \text{red}'(w, x)) \\ \text{INCONT } \text{book}'(w, x) \\ \text{PARTS } \langle x, w, \text{book}', \text{book}'(w, x), \text{red}', \text{red}'(w, x), \\ \text{book}'(w, x) \wedge \text{red}'(w, x), \iota x(\text{book}'(w, x) \wedge \text{red}'(w, x)) \rangle \end{array} \right]$$

This AVN describes linguistic objects which satisfy the conditions of the INCONT PRINCIPLE and would even satisfy the EXCONT PRINCIPLE if the NP itself were an independent utterance: The INCONT value is an element of the PARTS list and a subexpression of the EXCONT value. Furthermore the EXCONT value consists of all elements of the PARTS list and does not contain other semantic material.

Working in LRS we always have to address the question of which subexpressions of the logical form are contributed by which lexical item. In (21) we underline for each word in the NP the subexpressions it contributes.

(21) Meaning contributions:

the: $\underline{\iota x}(\text{book}'(w, x) \wedge \text{red}'(w, x))$ *red*: $\iota x(\underline{\text{book}'(w, x)} \wedge \underline{\text{red}'(w, x)})$
book: $\iota x(\underline{\text{book}'(w, x)} \wedge \text{red}'(w, x))$

Figure 3 shows the structure of the NP and the LF values for each node. The PARTS lists of the words consist of the expressions which we have underlined in (21). We must, next, state the principle which regulates the relation between the LF value of a phrase and the LF values of its daughters. This is done in the SEMANTICS PRINCIPLE. In (22) we will only give the clauses of the SEMANTICS PRINCIPLE which are relevant for our discussion.⁵

(22) The SEMANTICS PRINCIPLE:

- a. EXCONT and INCONT are shared along a head projection.
- b. The PARTS list of the mother contains exactly the elements of the daughters' PARTS lists.

⁴To keep the AVNs readable we will use logical expressions inside the AVNs and omit some subexpressions ($\text{book}'(w)$ and $\text{red}'(w)$ in (20)).

⁵Clauses for other syntactic structures can be found in Richter and Sailer (2004a).

Figure 3: The structure of the NP in (20)

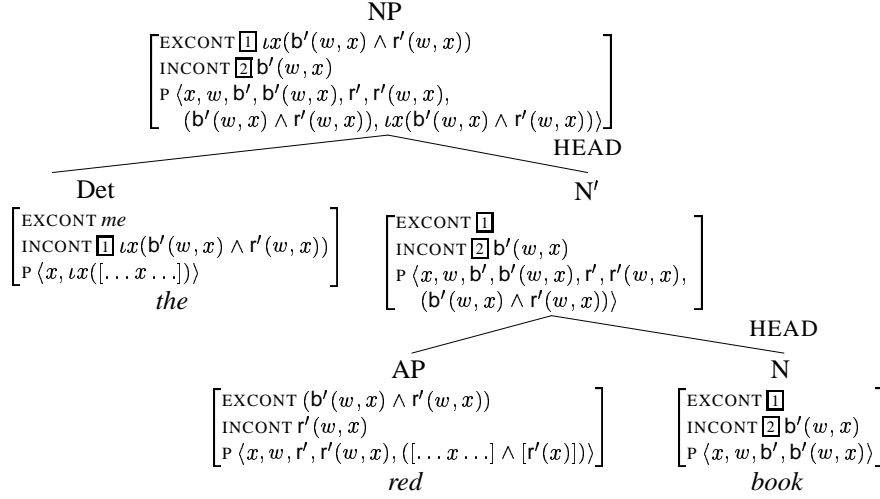

- c. If the nonhead is an intersective modifier which modifies a sign X , then the modifier's EXCONT is of the form $\alpha \wedge \beta$, and X 's INCONT is a subexpression of α .
- d. If the nonhead is a determiner, then the nonhead's INCONT and the head's EXCONT are identical, and the head's INCONT is a subexpression of the nonhead's restrictor.

Clause (a) determines that the INCONT value and the EXCONT value percolate along the head projection line. In Figure 3 the effect of this clause is reflected by the use of the tags $\boxed{1}$ and $\boxed{2}$.

Clause (b) guarantees that no semantic information is lost when signs are combined to larger units, nor that any semantic expressions are added. This is why LRS is *lexical*, i.e. all semantic expressions are contributed by lexical items. The syntactic structure can constrain the possible readings but not add new semantic material. This is in contrast to the more constructional approach of MRS.

Clause (c) is needed when a noun combines with an intersective modifier: The EXCONT value of an intersective modifier is a conjunction. The INCONT value of the head daughter must occur as a subexpression of the first conjunct.

Clause (d) describes the effect of a determiner combining with a head noun. Similar to the subexpression condition of clause (c), in clause (d) the INCONT value of the syntactic head is also required to appear as a subexpression of some expression of the nonhead. For a determiner, the noun's INCONT value must be within the restrictor of the determiner's INCONT.⁶ The effect of this condition can be seen in Figure 3 where the noun's INCONT value occurs inside the argument of the ι -operator. We have, thus, shown that the combinatorial mechanisms of LRS

⁶We subsume the only argument of the ι -operator under the notion of "restrictor", even though there is no "nuclear scope" in this case, in contrast to the situation with generalized quantifiers.

license the correct logical form for the given NP, i.e. the expression in (20).⁷

So far we have not mentioned where to locate the attribute LF inside a linguistic sign. Sailer (2004a) argues for a separation of *local* semantics and *semantic structure*, analogous to the distinction between syntactic category and syntactic structure in HPSG. Those aspects which are important for scope and the overall logical form occur inside the LF value. Information which is needed for linking or for semantic selection restrictions appear in the CONTENT value, which is embedded under *local* and, thus, can be accessed by a selector. This local semantic information will also contain the INDEX value. In addition to the ϕ -features which are usually found in the index, we will include an attribute, VAR, whose value is the referential variable associated with the given sign. The AVM in (23) demonstrates this separation for the word *book*.

(23) Outline of the semantic aspects of the word *book*:

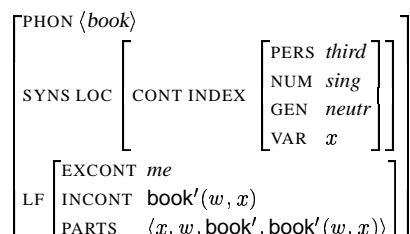

4 Analysis

After this brief introduction of the mechanisms of LRS we can address the analysis of the German relative clause data. In this section we will first present the analysis of a “normal”, i.e. semantically modifying, relative clause (Section 4.1), and then turn to the PRC readings in Section 4.2.

PRCs do not differ structurally from other relative clauses. Within HPSG most publications on German relative clauses, such as Kiss (2004) and Holler (2003), assume a variant of the analysis in Pollard and Sag (1994) rather than adopting the constructional approach in Sag (1997). As nothing depends on this, we will follow this line without further argumentation.

In German relative clauses often appear in extraposed position. This is also true for PRCs (see (1)). Kiss (2004) demonstrates that relative clauses are not “moved” into such an extraposed position — in contrast to complement clauses. In order to establish the semantic and agreement relation between an extraposed relative clause and the head noun, Kiss argues in favor of a system of combinatorial semantics which uses techniques of underspecified semantics, MRS in Kiss’ case. In Kiss’ analysis a relative clause can modify a noun which appears deeper in the

⁷There is one other expression which satisfies the indicated principles of LRS: $\iota x(\textit{book}'(w, x)) \wedge \textit{red}'(w, x)$. In this hypothetical logical form the entire ι -operator appears in the first conjunct. As a consequence the occurrence of the variable x in $\textit{red}'(w, x)$ is not bound by the ι -operator. We assume that such a reading will be excluded by general well-formedness conditions.

Figure 4: Syntactic structure of the sentences in (24) and (25)

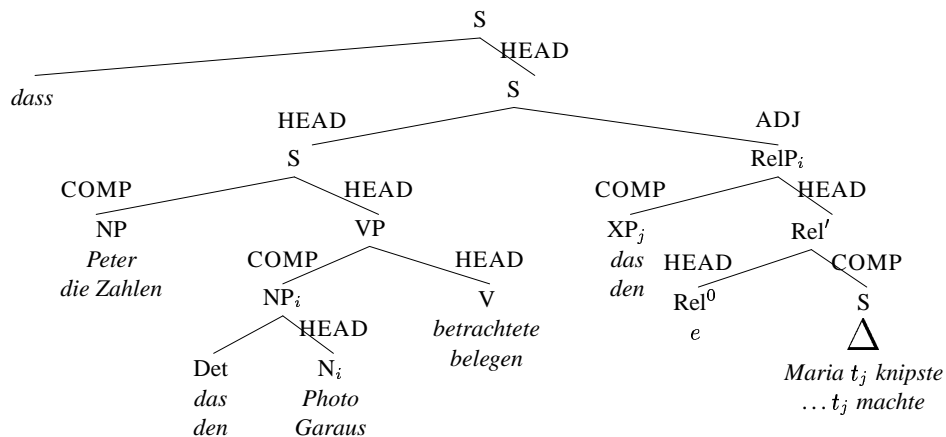

syntactic structure. In the present paper we will assume an LRS version of Kiss’ theory without providing the details.

We will illustrate our analysis with the following two sentences. Example (24) contains a normal relative clause, and (25) contains a PRC. We will also indicate the logical form. Our semantic representation language allows us to differentiate between semantic objects of different type (entities, eventualities, propositions). We will ignore tense.

- (24) dass Peter das Photo betrachtete, das Maria knipste.
 that Peter the picture looked.at which Maria took
 $\lambda w. \exists e (\text{look-at}'(w, e, p, \iota x (\text{picture}'(w, x) \wedge \exists e' (\text{take}'(w, e', m, x))))))$
- (25) dass die Zahlen den Garaus belegen, den die Globalisierung dem Kleinbetrieb machte.
 that the numbers the ?? prove which the globalization to the small business made
 $\lambda w. \exists e (\text{prove}'(w, e, Z, \lambda w. \exists e' (\text{make}'(w, e', G, K, \iota x (\text{garaus}'(w, x))))))$

Figure 4 outlines the syntactic structure of the sentences. In the following two subsections we will show how we can derive the correct readings for the sentences in (24) and (25) respectively.

4.1 The “Normal” Case

In this subsection we will combine the syntactic analysis of restrictive relative clauses with an LRS semantics. We will use sentence (24) as our running example. We will first consider the logical form of the deepest S node in Figure 4, then turn to the relative clause and finally address the question of how the relative clause and the rest of the sentence combine semantically.

The semantics of the NP *das Photo (the picture)* will be arrived at analogously

Figure 5: Outline of the lexical entry of *betrachten* (look at):

$$\left[\begin{array}{l} \text{PHON } \langle \textit{betrachten} \rangle \\ \text{SYNS LOC } \left[\begin{array}{l} \text{CAT ARG-ST } \langle \langle \text{LOC CONT INDEX VAR } y \rangle, \langle \text{LOC CONT INDEX VAR } x \rangle \rangle \\ \text{CONT } \langle \text{INDEX VAR } e \rangle \end{array} \right] \\ \text{LF } \left[\begin{array}{l} \text{EXCONT } \textit{me} \\ \text{INCONT } \textit{look-at}'(w, e, [\dots y \dots], [\dots x \dots]) \\ \text{PARTS } \langle w, e, y, x, \textit{look-at}', \lambda w.\alpha, \exists e\beta, \textit{look-at}'(w, e, [\dots y \dots], [\dots x \dots]) \rangle \end{array} \right] \end{array} \right]$$

and $\textit{look-at}' \triangleleft \beta$ **and** $\exists e\beta \triangleleft \alpha$

to the example in Figure 3. For the NP *Peter* the value of all semantic attributes (EXCONT, INCONT, the PARTS list, and VAR) only contains the constant *p*.

The lexical entry of the verb *betrachten* (look at) is outlined in Figure 5. A finite verb contributes a lambda abstract over the world index ($\lambda w.\alpha$), and an existentially quantified eventuality variable ($\exists e(\beta)$). We use Greek letters inside AVMS which should be read as meta variables over expressions of the semantic representation language. They indicate that we do not specify the given expression any further in the AVM. Multiple occurrences of the same meta variable refer to the same expression. Below the AVM we note some subexpression conditions. For example $\exists e(\beta)$ must be a subexpression of $\lambda w.\alpha$. This is expressed with a subexpression relation (“ \triangleleft ”), written as $\exists e(\beta) \triangleleft \alpha$.

The lexical entry in Figure 5 illustrates nicely how the VAR values of the complements are accessed in order to assign the complements the right slots in the argument positions of the constant $\textit{look-at}'$. This follows the strategy of argument identification of Pollard and Sag (1994). In our case, all we say is that the VAR values of the complements must occur somewhere inside the semantic argument slots, for which we write $[\dots x \dots]$ and $[\dots y \dots]$.

We can now look at the VP and the S node. Since all complements in our examples are definite NPs the SEMANTICS PRINCIPLE does not introduce new subexpression requirements. Nonetheless we can be more specific about the argument slots of the constant $\textit{look-at}'$. The constant *p* will fill the agent slot. We also know at this stage that the expression $\textit{picture}'(w, x)$ occurs in the scope of the ι -operator, but other material might be in there as well. We indicate this “...”. In (26) we describe the logical form of the discussed S node.

(26) The Irs of *Peter das Photo betrachtete*:

$$\left[\begin{array}{l} \text{EXCONT } \textit{me} \\ \text{INCONT } \textit{look-at}'(w, e, p, [\dots x \dots]) \\ \text{PARTS } \langle w, e, p, x, \lambda w.\dots, \exists e(\dots), \textit{look-at}', \textit{look-at}'(w, e, p, [\dots x \dots]), \textit{picture}', \textit{picture}'(w, x), \iota x(\dots \textit{picture}'(w, x) \dots) \rangle \end{array} \right]$$

The logical form of the S node inside the relative clause is built in a parallel fashion. The VAR value of the trace is identical to that of the relative pronoun, which follows from the identity of their LOCAL. The LF value will not add semantic expressions which are not in CONTENT already. We can now describe the LF value of the relative clause internal S node:

Figure 6: The empty relativizer (adapted from (Pollard and Sag, 1994, p. 216))

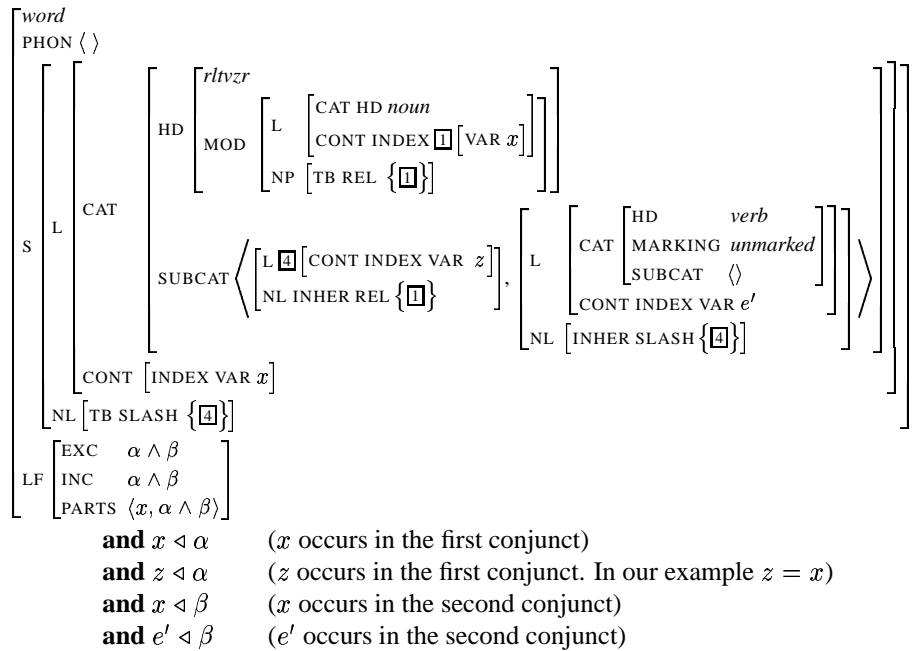

(27) The lrs of *Mary t knipste* (*Mary took t*):

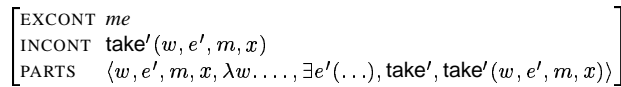

The syntactic structure of a relative clause contains a phonologically empty relativizer according to our assumption. In Figure 6 we will adapt the lexical entry of the empty relativizer from Pollard and Sag (1994) to LRS. We will indicate the effect of the subexpression conditions in brackets for a better readability.

Semantically the empty relativizer only contributes its referential variable (x) and a coordination ($\alpha \wedge \beta$). The subexpression conditions determine that the VAR value of the noun to which the relative clause attaches (x) must occur in both conjuncts. Furthermore the contribution of the S-part of the relative clause must be integrated into the second conjunct. This is expressed by the condition on the event variable e' , which is the VAR value of the S-part of the relative clause. Since our examples do not involve pied-piping, we do not have to distinguish between the VAR value of the relative constituent and that of the noun in the MOD (i.e. $x = z$).

When the relativizer combines with its S complement the SEMANTICS PRINCIPLE does not introduce new subexpression conditions. The semantics of the relative pronoun is, again, maximally simple. It only contributes the variable which occurs in its VAR value. Therefore no subexpression conditions are added in the combination of the relative pronoun and the Rel' . The AVM in (28) describes the logical form of the relative clause.

(28) The lrs of the relative clause:

$$\left[\begin{array}{l} \text{EXCONT} \ [\dots x \dots] \wedge [\exists e'([\dots \text{take}'(w, e', m, x) \dots])] \\ \text{INCONT} \ [\dots x \dots] \wedge [\exists e'([\dots \text{take}'(w, e', m, x) \dots])] \\ \text{PARTS} \ \langle w, e', m, x, \lambda w. \dots, \exists e'(\dots), \text{take}', \text{take}'(w, e', m, x) \rangle \end{array} \right]$$

In the next step we will combine the RelS with the rest of the sentence. Syntax will ensure that the RelS has the same INDEX VAR value as the noun *picture*. As stated in (28), this value must appear in both conjuncts.

According to (c) of the SEMANTICS PRINCIPLE the INCONT value of the noun must be a subexpression of the first conjunct. Therefore the conjunction must be of the following shape.

$$(29) \ [\dots \text{picture}'(w, x) \dots] \wedge [\exists e'([\dots \text{take}'(w, e', m, x) \dots])] \wedge [\dots]$$

The entire conjunction must be a subexpression of $\iota x(\dots)$ in order to bind all occurrences of x . This leads to the following logical form:

$$(30) \ \iota x([\dots \text{picture}'(w, x) \dots] \wedge [\exists e'([\dots \text{take}'(w, e', m, x) \dots])]) \wedge [\dots]$$

$\iota x(\dots)$ is of type e and, thus, of the appropriate type for the argument position of *look-at'*. Therefore the expression in (30) can occur there. The relative clause also contributes an abstraction over the world index ($\lambda w. \dots$). This abstraction must be outside the scope of the ι -operator. Here it is identical with $\lambda w. \alpha$.

Since no more semantic material will be introduced into the sentence, the EXCONT value of the sentence must contain exactly the elements of its PARTS list. This results in the logical form given in (24), repeated in (31).

$$(31) \ \lambda w. \exists e(\text{look-at}'(w, e, p, \iota x(\text{picture}'(w, x) \wedge \exists e'(\text{take}'(w, e', m, x)))))) \wedge [\dots]$$

In this subsection we showed that the standard reading of relative clauses can be accounted for by reformulating the semantics of the empty relativizer of Pollard and Sag (1994) in terms of the LRS treatment of intersective modifiers.

4.2 The PRC Case

We will now demonstrate that the PRC reading of (25) can be derived without adding anything new to the present analysis.

The lexical entry of the verb *belegen* (*prove*) is analogous to that of the verb *betrachten* in Figure 5. The only difference concerns the semantic type of the last argument slot. In the case of *betrachten* we assumed that this argument is of type e , for *belegen* it must be a proposition, i.e. of type st .

For simplicity we will abbreviate the semantic contribution of the NPs which are not relevant to the present discussion by upper case letters (Z, G, K). The bound word *Garaus* will be treated analogously to *book* in (23), i.e., it introduces a semantic constant *garaus'*. We will not provide a treatment of bound words in

this paper.⁸ Any account of *Garaus* must ensure that the noun cannot be modified. Therefore the logical form of the NP *den Garaus* is $\iota x(\text{garaus}'(x))$. In contrast to the NP *das Photo* there is no option for inserting further semantic material inside the scope of the ι -operator. We will state the logical form of the lowest S node in (32).

(32) The lrs of *die Zahlen den Garaus belegen*:

$$\left[\begin{array}{l} \text{EXCONT } me \\ \text{INCONT } \text{prove}'(w, e, Z, [\dots x \dots]_{st}) \\ \text{PARTS } \langle w, e, Z, x, \lambda w \dots, \exists e(\dots), \text{prove}', \text{prove}'(w, e, Z, [\dots x \dots]), \\ \text{garaus}', \text{garaus}'(w, x), \iota x(\text{garaus}'(w, x)) \rangle \end{array} \right]$$

The logical form of the S-part of the relative clause is constructed parallel to the previous case. This leads to the following LF value.

(33) The lrs of *die Globalisierung dem Kleinbetrieb t machte*:

$$\left[\begin{array}{l} \text{EXCONT } me \\ \text{INCONT } \text{make}'(w, e', G, K, [\dots x \dots]) \\ \text{PARTS } \langle w, e', G, K, x, \lambda w \dots, \exists e'(\dots), \text{make}', \text{make}'(w, e', G, K, [\dots x \dots]) \rangle \end{array} \right]$$

If we combine this clause with the empty relativizer in Figure 6 and with the relative pronoun, we will arrive at the logical form of an intersective modifier.

(34) The lrs of the relative clause:

$$\left[\begin{array}{l} \text{EXCONT } [\dots x \dots] \wedge [\exists e'([\text{make}'(w, e', G, K, [\dots x \dots])])] \\ \text{INCONT } [\dots x \dots] \wedge [\exists e'([\text{make}'(w, e', G, K, [\dots x \dots])])] \\ \text{PARTS } \langle w, e', G, K, x, \lambda w \dots, \exists e'(\dots), \text{make}', \text{make}'(w, e', G, K, [\dots x \dots]) \rangle \end{array} \right]$$

We can now combine the RelS with the rest of the sentence. Again the syntactic analysis will guarantee that the RelS has the same INDEX VAR value as the noun *Garaus*. As we have seen this value appears in both conjuncts of the relative clause semantics. According to (c) of the SEMANTICS PRINCIPLE the INCONT value of the noun must be a subexpression of the first conjunct. Thus, we know that the conjunction must contain the following semantic material.

(35) $[\dots \text{garaus}'(w, x) \dots] \wedge [\exists e'([\text{make}'(w, e', G, K, [\dots x \dots])])]$

The noun *Garaus* cannot be modified, therefore the coordination cannot be in the scope of ιx , even though this would be the standard logical form for a restrictive relative clause to a definite NP. Since this standard logical form is not available, we must ask whether there is a way to combine the semantic contributions into a well-formed expression at all. In (36) we present a logical form which solves the apparent problem.

(36) $\lambda w. \exists e'([\text{make}'(w, e', G, K, \iota x(\text{garaus}'(w, x))) \wedge \text{make}'(w, e', G, K, \iota x(\text{garaus}'(w, x)))])$

⁸But see Riehemann (2001), Richter and Sailer (2003) or Soehn and Sailer (2003).

This expression satisfies all subexpression conditions: (i) The semantic contribution of the S-part of the relative clause occurs in the second conjunct. (ii) The variable x occurs in both conjuncts. (iii) The INCONT value of the NP *den Garaus* ($\text{garaus}'(w, x)$) occurs in the first conjunct. The fact that the same material appears in both conjuncts is compatible with these requirements.

We do not even have to assume that the expression $\text{garaus}'(w, x)$ was added twice to the PARTS list. Instead, we can simply use the identical expression, but assume that there are two paths through the overall expression which lead to $\text{garaus}'(w, x)$. But this is an independent property of our HPSG encoding of semantic expressions, as we have seen in Section 3.1. We will outline the HPSG encoding of the conjunction in the following AVM. This AVM shows that the two conjuncts have identical subexpressions.

(37) HPSG encoding of the conjunction in (36):

$$\left[\begin{array}{l} \text{coordination} \\ \text{C1 } \square \text{ make}'(w, e', G, K, \iota x(\text{garaus}'(w, x))) \\ \text{C2 } \square \end{array} \right]$$

Let us turn back to the expression in (36). This expression is of type st and can, thus, be used as the semantic argument of $\text{prove}'(w, e, Z, [\dots x \dots])$. This leads to the following logical form.

$$(38) \quad \lambda w. \exists e (\text{prove}'(w, e, Z, \lambda w. \exists e' ((\text{make}'(w, e', G, K, \iota x(\text{garaus}'(w, x))) \wedge \text{make}'(w, e', G, K, \iota x(\text{garaus}'(w, x)))))))$$

This logical form is equivalent to the one we gave in (25). It is of course more complicated because it consists of an extra conjunction. But since the two conjuncts are identical, there is no difference in their truth conditions.

In this subsection we demonstrated that the mechanisms of LRS can account for the PRC reading without any stipulation. It should be noticed that we could not have derived a PRC reading for example (24), because the matrix verb does not take a propositional argument.

5 Reflections and Conclusion

Our analysis of PRCs relied on the possibility to use identities of semantic expressions. As illustrated in Section 3.1 this possibility follows from the fact that LRS is fully integrated into HPSG, for which identities are a central analytical device.

Identities have already played an important role in the LRS analysis of concord phenomena. For examples such as (39) Richter and Sailer (2004b) argue that both the preverbal marker *nie* and the n-word *nikomu* contribute a negation to the overall logical form. A language specific principle will specify that Polish does not allow for two negations in one clause — in contrast to French, for example. This principle enforces that the two items contribute the same negation.

- (39) Janek nie pomaga nikomu (Polish)
Janek NM helped nobody
'Janek didn't help anybody.'

While identities lead to simpler logical forms in concord constellations, in the current analysis of PRCs, identity is used to “multiply” bits of logical form. This is possible because the conjunction introduced by the relativizer needs two conjuncts of the same semantic type, so we can use the same conjunct twice. Notice that the two conjuncts must be fully identical, i.e., this mechanism does not cover the potential of the so-called *equality-up-to*-constraints in Pinkal (1996) or Egg et al. (2001). It is an empirical question whether we can find more phenomena for which an analysis in terms of “multiplying” may be attractive.

The account presented seems to predict a general ambiguity of relative clauses. Note however that the availability of a PRC reading is correctly restricted to certain matrix predicates. For example we could not have derived a PRC reading for sentence (24). To explain the often dubious grammaticality status of PRC readings we may assume that speakers tend to avoid redundant logical forms, in particular since normally relative clauses can be interpreted without such a redundancy.

In principle the presented analysis can be adapted to other systems of combinatorial semantics which use techniques of underspecification. We saw, however, that it is important to rely on a semantic representation language which allows to distinguish individuals and propositions to prevent overgeneration. Furthermore so far identities of logical expressions have not been exploited in other systems to our knowledge.

References

- Borsley, Robert D. 1997. Relative Clauses and the Theory of Phrase Structure. *Linguistic Inquiry* 28(4), 629–647.
- Borsley, Robert D. nd. More on the Raising Analysis of Relative Clauses, unpublished manuscript, University of Essex.
- Bos, Johan. 1996. Predicate Logic Unplugged. In Paul Dekker and Martin Stokhof (eds.), *Proceedings of the Tenth Amsterdam Colloquium*, pages 133–143, ILLC/Department of Philosophy, University of Amsterdam.
- Bouma, Gosse. 2003. Verb Clusters and the Scope of Adjuncts in Dutch. In Pieter A. M. Seuren and Gerard Kempen (eds.), *Verb Constructions in German and Dutch*, Amsterdam and Philadelphia: John Benjamins.
- Carlson, Greg N. 1977. Amount Relatives. *Language* 53, 520–542.
- Copestake, Ann, Flickinger, Dan, Pollard, Carl and Sag, Ivan A. 2003. Minimal Recursion Semantics: An Introduction, manuscript.

- Egg, Markus. 2002. Semantic Construction for Reinterpretation Phenomena. *Linguistics* 40, 579–609.
- Egg, Markus and Erk, Katrin. 2002. A Compositional Account of VP Ellipsis. In Frank Van Eynde, Lars Hellan and Dorothee Beermann (eds.), *Proceedings of the 8th International Conference on Head-Driven Phrase Structure Grammar*, pages 162–179, Stanford: CSLI Publications.
- Egg, Markus, Koller, Alexander and Niehren, Joachim. 2001. The Constraint Language for Lambda Structures. *Journal of Logic, Language and Information* 10(4), 457–485.
- Frank, Anette and Reyle, Uwe. 1995. Principle Based Semantics for HPSG. In *Proceedings of the Seventh Conference of the European Chapter of the Association for Computational Linguistics*, pages 9–16, Association for Computational Linguistics.
- Gallin, Daniel. 1975. *Intensional and Higher-Order Modal Logic*. Amsterdam: North-Holland.
- Holler, Anke. 2003. An HPSG Analysis of the Non-Integrated Wh-Relative Clauses in German. In Stefan Müller (ed.), *Proceedings of the HPSG-2003 Conference, Michigan State University, East Lansing*, pages 163–180, CSLI Publications.
- Hulsey, Sarah and Sauerland, Uli. 2002. Sorting out Relative Clauses: A Reply to Bhatt, available at the Semantics Archive.
- Kiss, Tibor. 2004. Semantic Constraints on Relative Clause Extraposition. *Natural Language and Linguistic Theory* To appear.
- Krifka, Manfred. 2004. Bare NPs: Kind-referring, Indefinites, Both, or Neither? In Olivier Bonami and Patricia Cabredo Hofherr (eds.), *Empirical Issues in Formal Syntax and Semantics 5*, pages 111–132.
- Nunberg, Geoffrey, Sag, Ivan A. and Wasow, Thomas. 1994. Idioms. *Language* 70, 491–538.
- Pinkal, Manfred. 1996. Radical Underspecification. In Paul Dekker and Martin Stokhof (eds.), *Proceedings of the Tenth Amsterdam Colloquium*, pages 587 – 606, ILLC/Department of Philosophy, University of Amsterdam.
- Pollard, Carl and Sag, Ivan A. 1994. *Head-Driven Phrase Structure Grammar*. Chicago and London: University of Chicago Press.
- Reyle, Uwe. 1993. Dealing with Ambiguities by Underspecification: Construction, Representation and Deduction. *Journal of Semantics* 10(2), 123–179.

- Richter, Frank and Sailer, Manfred. 2001. On the Left Periphery of German Finite Sentences. In W. Detmar Meurers and Tibor Kiss (eds.), *Constraint-Based Approaches to Germanic Syntax*, pages 257–300, Stanford: CSLI Publications.
- Richter, Frank and Sailer, Manfred. 2003. Cranberry Words in Formal Grammar. In Claire Beyssade, Olivier Bonami, Patricia Cabredo Hofherr and Francis Corblin (eds.), *Empirical Issues in Formal Syntax and Semantics 4*, pages 155–171, Paris: Presses Universitaires de Paris-Sorbonne.
- Richter, Frank and Sailer, Manfred. 2004a. Basic Concepts of Lexical Resource Semantics. In *ESSLLI 2003 – Course Material I*, volume 5 of *Collegium Logicum*, Kurt Gödel Society Wien.
- Richter, Frank and Sailer, Manfred. 2004b. Polish Negation and Lexical Resource Semantics. In Lawrence S. Moss and Richard T. Oehrle (eds.), *Electronic Notes in Theoretical Computer Science*, volume 53, Elsevier.
- Riehemann, Susanne Z. 2001. *A Constructional Approach to Idioms and Word Formation*. Ph. D.thesis, Stanford University.
- Sag, Ivan A. 1997. English Relative Clause Constructions. *Journal of Linguistics* 33, 431–483.
- Sailer, Manfred. 2003. Combinatorial Semantics and Idiomatic Expressions in Head-Driven Phrase Structure Grammar. Phil. Dissertation (2000). Arbeitspapiere des SFB 340. 161, Universität Stuttgart and Universität Tübingen.
- Sailer, Manfred. 2004a. Local Semantics in HPSG. In Olivier Bonami and Patricia Cabredo Hofherr (eds.), *Empirical Issues in Formal Syntax and Semantics 5*, pages 197–214.
- Sailer, Manfred. 2004b. Past Tense Marking in Afrikaans. In *Proceedings of Sinn und Bedeutung 8*, to appear.
- Soehn, Jan-Philipp and Sailer, Manfred. 2003. At First Blush on Tenterhooks. About Selectional Restrictions Imposed by Nonheads. In Gerhard Jäger, Paola Monachesi, Gerald Penn and Shuly Wintner (eds.), *Proceedings of Formal Grammar 2003*, pages 149–161.
- Valentina, Bianchi. 2000. The Raising Analysis of Relative Clauses: A Reply to Borsley. *Linguistic Inquiry* 31(1), 123–140.
- Vergnaud, Jean Roger. 1974. *French Relative Clauses*. Ph. D.thesis, MIT.

Head-initial constructions in Japanese

Melanie Siegel 

University of Saarbrücken

Emily M. Bender 

University of Washington

Proceedings of the 11th International Conference on
Head-Driven Phrase Structure Grammar

Center for Computational Linguistics, Katholieke Universiteit Leuven

Stefan Müller (Editor)

2004

Stanford, CA: CSLI Publications

pages 244–260

Siegel, Melanie & Emily M. Bender. 2004. Head-initial constructions in Japanese. In Stefan Müller (ed.), *Proceedings of the 11th International Conference on Head-Driven Phrase Structure Grammar*, Center for Computational Linguistics, Katholieke Universiteit Leuven, 244–260. Stanford, CA: CSLI Publications. DOI: 10.21248/hpsg.2004.14.



Abstract

Japanese is often taken to be strictly head-final in its syntax. In our work on a broad-coverage, precision implemented HPSG for Japanese, we have found that while this is generally true, there are nonetheless a few minor exceptions to the broad trend. In this paper, we describe the grammar engineering project, present the exceptions we have found, and conclude that this kind of phenomenon motivates on the one hand the HPSG type hierarchical approach which allows for the statement of both broad generalizations and exceptions to those generalizations and on the other hand the usefulness of grammar engineering as a means of testing linguistic hypotheses.

1 Introduction

Japanese is generally taken to be strictly head-final in its syntax (Gunji, 1987). Broad claims like this can be tested by implementing grammars for large fragments of the language and testing them against naturally occurring text. In our work on a broad-coverage, precision implemented HPSG for Japanese, we have found a few minor exceptions to the broad trend towards head-final order in Japanese. The remainder of this section describes the grammar engineering project and the kinds of linguistic data so far considered. Section 2 discusses how to identify heads and presents the general trend towards right-headedness in Japanese syntax. Sections 3 and 4 describe and motivate the two kinds of exceptions we have found: head-initial modification and head-initial complementation. In Section 5 we conclude that this kind of phenomenon motivates on the one hand the HPSG type hierarchical approach which allows for the statement of both broad generalizations and exceptions to those generalizations and on the other hand the usefulness of grammar engineering as a means of testing linguistic hypotheses. The analyses are presented in greater detail in the appendix.

Our Japanese HPSG grammar originates from work done in several research projects concerning different domains. The grammar is couched in the theoretical framework of Head-Driven Phrase Structure Grammar (HPSG) (Pollard and Sag, 1994), with semantic representations in Minimal Recursion Semantics (MRS) (Copestake et al., 2003). We use the ChaSen tokenizer and POS tagger (Matsumoto et al., 2000). In the context of a broader multilingual grammar engineering effort, JACY has been made compatible with the Grammar Matrix (Bender et al., 2002), including incorporating Matrix types. One of the benefits of Matrix-compatibility is that the MRS representations produced by the grammar are consistent with those produce by Matrix-derived grammars for other languages. This improves interoperability with back-end systems.

[†]We would like to thank Atsuko Shimada for assistance with data questions and the JACY grammar in general; Francis Bond for his work on JACY; YY Technologies, DFKI, and Project DeepThought for opportunities to develop the grammar; and three anonymous reviewers for the HPSG conference for valuable suggestions and comments. All remaining errors are our own.

JACY was first implemented for the use in Machine Translation of spoken dialogs (Verbmobil; Siegel, 2000). The next application area was interpreting email for automated response (Oepen et al., 2002). Project DeepThought¹ embedded the Japanese grammar in a multilingual grammar development framework for hybrid natural language processing (Uszkoreit et al., 2004). All of these development contexts share the following characteristics: (i) The grammar was deployed in practical applications and developed to handle large and realistic corpora. (ii) The domain focus is spoken or near-spoken language. Such development contexts require the treatment of core as well as peripheral phenomena of the language. In extending coverage to more peripheral phenomena, we have found some which are best treated as head-initial, including both head-complement constructions (number names and certain uses of numeral classifiers) and head-modifier constructions (head-initial modification of nouns, postpositional phrases, verbs and temporal expressions).

The grammar implementation is based on a system of types. There are 900 lexical types that define the syntactic, semantic and pragmatic properties of the Japanese words, and 188 types that define the properties of phrases and lexical rules. The grammar includes 50 lexical rules for inflectional and derivational morphology and 47 phrase structure rules. The lexicon contains about 30000 stem entries and 31 default lexical types for items that can be POS tagged by ChaSen, but are not included in the HPSG lexicon. JACY is open-source and downloadable from <http://www.dfki.de/~siegel/grammar-download/JACYgrammar.html>.

2 The position of syntactic heads in Japanese

Zwicky (1993) identifies several characteristics which have been taken to differentiate heads and dependents, and points out that they do not correlate all that well.²

	Head	Dependent
Semantics	characterizing	contributory
Syntax	required	accessory
	word rank	phrase rank
	category determinant	non-determinant
Morphology	external representative	externally transparent
	morpho-syntactic locus	morpho-syntactically irrelevant

Table 1: Characteristics of heads and dependents, from Zwicky 1993

HPSG theory only recognizes some of these characteristics in the identifica-

¹<http://www.project-deepthought.net>

²In modifier constructions, the semantic functor is not the head, but the modifier, cf. Zwicky 1993.

tion of syntactic heads,³ namely required v. accessory, category determinant v. non-determinant, and external representative v. externally transparent. The central intuition is that the syntactic head of a construction is that subconstituent which determines the syntactic distribution of the whole.

This notion of head is, of course, fundamental to HPSG and is encoded in the head-feature (Pollard and Sag, 1994) and subcategorization (Borsley, 1993) principles. Given an HPSG grammar, the head of any constituent parsed by the grammar is well-defined. The HEAD values encode precisely the kind of part of speech information which determines the syntactic distribution of an element (such as case, preposition form, and modification possibilities) and the head feature principle propagates this information to the mother of the phrase. Likewise, the subcategorization principle distinguishes heads from arguments, in general making the valence requirements of a phrase some function of the valence requirements of its head.⁴ Determining which element is the head for the purposes of writing the grammar, on the other hand, can be trickier. Deciding on the head constituent in a phrase requires observing which constituent contributes the head information and the subcategorization information.

By this definition, it is true that most heads in Japanese follow both arguments and adjuncts: Verbs appear at the end of clauses, as can be seen in example (1).⁵

- (1) Tanaka ga hon wo yonda.
Tanaka NOM book ACC read.past
'Tanaka read a book.'

Adjectives, genitives, and relative clauses precede nouns:

- (2) Tanaka no yasashii tomodachi ga kita.
Tanaka GEN nice friend NOM come.past
'Tanaka's nice friend came.'

The language has postpositions, including both contentful elements such as *kara* 'from' (3), and the case marking postpositions *ga*, *wo*, *ni* (4), which both follow nouns.

- (3) Toukyou kara kita
Tokyo from come.past
'(someone) came from Tokyo.'

³Note that the syntactic head need not be the semantic head.

⁴In some cases these 'functions' get fairly elaborate and also refer to the valence requirements of the non-head daughter, as in argument transfer and composition in constructions like that combining verbal nouns and light verbs in Japanese.

⁵Abbreviations used in this paper are as follows: ACC accusative, AUX auxiliary, COP copula, GEN genitive, INSTR instrumental, LOC locative, NEG negative, NOM nominative, NUMCL numeral classifier, TOP topic, Q interrogative particle.

- (4) Nanji kara ga yoroshii desu ka?
 What time from NOM good COP Q
 ‘From what time would be good?’

That contentful postpositions should head their phrases is relatively uncontroversial. Applying the same treatment to the case markers might be more surprising, especially as they are sometimes considered to be nominal inflection (e.g., Sag et al., 2003). However, Siegel (1999) makes the case for treating them as heads. We illustrate the argument here with the examples in (3)–(5), which show that *ga* is crucial in determining the combinatoric potential of its phrase.

- (5) a. Nanji kara atsumarimasu ka?
 What time from gather Q
 ‘From what time are people gathering?’
 b.*Nanji kara ga atsumarimasu ka?
 What time from NOM gather Q

In (4), there is a single constituent (*Nanji kara ga*) containing both a contentful postposition (*kara* ‘from’) and a case-marking postposition *ga*. Constituents ending in *kara* are verbal adjuncts ((3) and (5a)). When *ga* attaches, the result is eligible to appear in an argument (here, subject) position (4), and no longer can appear as a verbal adjunct (5b). If *ga* were merely a marker that otherwise preserved the category information of the constituent it attaches to, this behavior would be hard to explain. Note that on this analysis, the Japanese case particles look fairly similar to English ‘case-marking prepositions’, such as *to* in *Kim gave the book to Sandy*. For our purposes here, the main point is that PPs, with both contentful and case marking postpositions, are also head-final.⁶

We now turn to the exceptions we have found to the general head-final trend, which can be classified into two groups: head-initial modification and head-initial complementation.

3 Head-initial modification

3.1 Data

Using the definition above of the syntactic head in a construction, we can find some elements that behave as non-heads, although they occur final in a construction. In this class, we find the modifiers *dake*, *nomi*, *bakari* (in two distinct uses), *goro*, *kurai*, *hodo*, and certain instances of numeral classifiers.

⁶In general, distinguishing morphology and syntax is not very clear-cut in this agglutinating language (Shibatani and Kageyama, 1988; Kageyama, 2001). For better or for worse, the orthography does not provide any clues, lacking inter-word spaces. For practical (engineering) purposes, we tend towards regarding syntax over morphology, as ChaSen provides near-morpheme-level segmentation. Along the way, we will point out evidence that the cases presented here involve syntactically separate words (clitics or otherwise).

3.1.1 *Dake*

The modifier *dake* ‘only’ modifies at least NPs, predicative PPs, and adverbs.

The noun-modification use is illustrated in (6):

- (6) a. *Nomura-san dake ga kita.*
 Ms. Nomura only NOM come.past
 ‘Only Ms. Nomura came’
- b. *Nomura-san ga kita.*
 Ms. Nomura NOM come.past
 ‘Ms. Nomura came’
- c. **Dake (ga) kita.*
 only NOM come.past

The head of the construction *Nomura-san dake ga* is the case particle *ga* (see above). The head of *Nomura-san dake* must be *Nomura-san*, because *ga* selects for a noun. Leaving *dake* out in this construction leads to a grammatical sentence *Nomura-san ga kita.*, while leaving *Nomura-san* out gives an ungrammatical sentence. *Dake* is optional in all registers, the noun is obligatory in all, and the case particle is obligatory in some. Therefore we conclude that *dake* in this construction is a modifier to *Nomura-san*, even though it follows the head.

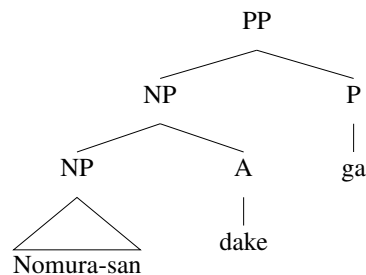

Figure 1: Structure of PP with *dake*

The predicative PPs modifier use of *dake* is illustrated in (7):

- (7) *Riyousha wa toukyou kara (dake) de-wa-nai.*
 Users TOP Tokyo from (only) COP-NEG
 ‘The users were not only from Tokyo.’

The fact that *dake* is optional in this example lends support to the conclusion that *toukyou kara dake* is a head-initial construction. Further support comes from the fact that the order of the particles is flexible, as illustrated in (8) (from Makino and Tsutsui, 1986, 95).

- (8) a. Kono kuruma wa arukouru de dake ugokemasu.
 This car TOP alcohol INST only move
 ‘This car runs only on alcohol.’
- b. Kono kuruma wa arukouru dake de ugokemasu.
 This car TOP alcohol only INST move
 ‘This car runs on alcohol alone’

As indicated in the glosses, *dake* can modify (semantically as well as syntactically) either the NP or the PP. It can appear in either position without affecting combinatoric potential. Thus, *arukouru de dake* and *arukouru dake* are head-initial

Finally, adverbs can also be modified (head-initially) by *dake*, as illustrated in (9) (from Makino and Tsutsui, 1986, 94).

- (9) Watashi wa nihon e ichido (dake) itta.
 I TOP Japan to once (only) went
 ‘I went to Japan (only) once.’

To summarize the observations for *dake*, we can say that it combines with (at least) NP, PP, and ADV to form a category of the same type. The relative non-specificity of the host suggests a syntactic rather than a morphological combination. The distributional facts support treating *dake* as a non-head, even though it is final in its constituent.⁷

A second element, *nomi* ‘only’, is very similar to *dake*, except that it cannot follow adjectives and quantifiers. It is used in formal speech and written Japanese, but seldom in the registers found in our corpora.

3.1.2 *Bakari* ‘only’

Our second example is *bakari* ‘only’. It can modify PPs and VPs (or possibly Vs). Consider first the example in (10a), from the newspaper *Mainichi Shinbun*.⁸ Here, *bakari* is a PP modifier:

- (10) a. [ⓐ]Shoutotsu ni bakari kanshin ga atsumatta.
 collision to only concern *nom* collected
 ‘It is only on the collision that concern is concentrated.’
- b. Shoutotsu ni kanshin ga atsumatta.
 collision to concern NOM collected
 ‘It is on the collision that concern is concentrated.’
- c. *Shoutotsu bakari kanshin ga atsumatta.
 collision only concern NOM collected

⁷Makino and Tsutsui (1986) also note a use of *dake* where it attaches to verbs and adjectives to make nominal constituents. In this case, *dake* appears to be a nominalizing head and the examples are not relevant to the point at hand.

⁸Following Bender and Kathol (In press), we mark attested examples with [ⓐ].

In this example, the particle NI ‘to’ determines the combinatoric potential of the whole phrase, leaving *bakari* the role of a modifier.

There are also examples of head-initial verb modification, including the following attested in *Mainichi Shinbun* in 2002:

- (11) ①Gakkou no sensei wo okorasete bakari ita
 school GEN teacher ACC upset only AUX
 ‘The only thing he was doing was upsetting the school’s teacher.’

This is one exception to the general rule that nothing should intervene between a verb in the *-te* form and an auxiliary. The exception can be handled if *bakari* modifies *okorasete*. We therefore introduce one instance of *bakari* that can be a post-head modifier of verbs with *-te* inflection.⁹

3.1.3 *Bakari* and other forms meaning ‘about’

There is another post-head modifier *bakari* meaning ‘about’, which modifies temporal expressions. We illustrate it here with another *Mainichi Shinbun* example:

- (12) ①Toukyou kara kuruma de nijikan bakari no kinkou no onsen ni
 Tokyo from car INST 2 hours about GEN suburb GEN hot spring to
 asa shichiji goro shuppatsu-suru.
 morning 7 o’clock around depart
 ‘We depart at about 7 a.m. for a hot spring in the suburbs which is about two hours from Tokyo by car.’

The relevant construction here is *nijikan bakari no*. The head of the construction is *no*, because it carries the information that the construction can modify an NP. *No*, in turn, selects for the temporal noun *nijikan* and *nanjikan* is modified by *bakari*. The sentence would be perfectly grammatical without *bakari*.

Similarly, for *goro*, *kurai* and *hodo* (about), one finds several examples for head-initial modification of temporal expressions, such as (13):

- (13) Kyou nanji goro made nete imashita ka?
 today what time about until sleep AUX.past Q
 ‘Until about what time did you sleep today?’

Leaving out *goro* in (14a) simply removes the ‘approximate’ meaning from the sentence, while leaving out *nanji* (14b) changes the meaning drastically: *Goro* becomes a modifier of *kyou*. Leaving out *made* (14c) gives the sentence another meaning, ‘At about what time did you fall asleep today?’. Leaving out both *goro* and *made* gives ‘At what time did you fall asleep today?’.

⁹An anonymous reviewer points out that the class of elements which can appear in this position also includes *wa*, *mo*, *dake*, *koso*, *sae*, and *made*. Many, if not all of the elements, should be susceptible to a similar analysis.

- (14) a. Kyou nanji made nete imashita ka?
 today what time until sleep AUX.past Q
 ‘Until what time did you sleep today?’
- b. Kyou goro made nete imashita ka?
 today about until sleep AUX.past Q
 ‘Were you sleeping until about today?’
- c. Kyou nanji goro nete imashita ka?
 today what time about sleep AUX.past Q
 ‘At about what time did you fall asleep today?’
- d. Kyou nanji nete imashita ka?
 today what time sleep AUX.past Q
 ‘At what time did you fall asleep today?’

Once again, we see a modifier (*goro*) which can attach to multiple different constituents. Unlike *made*, *goro* does not affect the way the constituent it is attached to interacts with the rest of the sentence. Therefore, we propose the structure in Figure 2 for *nanji goro made*.

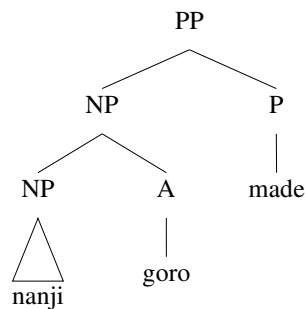

Figure 2: Structure of *nanji goro made* ‘until about what time’

3.1.4 Numeral classifiers

Finally, on our analysis, numeral classifier phrases appearing between a noun and its case particle or immediately after a case particle are post-head modifiers. Some examples are given in (15). See Bender and Siegel, 2004 for further details.

- (15) a. Neko ni hiki wo kau.
 cat 2 NUMCL ACC raise
 ‘(I) am raising two cats.’
- b. Neko wo ni hiki ie de kau.
 cat ACC 2 NUMCL house LOC raise
 ‘(I) am raising two cats in my house.’

3.1.5 Summary

In this section, we have seen post-head modification of nominal, postpositional, adverbial and verbal constituents. Many of the modifiers can modify multiple different parts of speech. Others (numeral classifier phrases) are internally complex (potentially containing arbitrarily large number names) and further more can appear before or after the phrases they modify, or ‘floated’ away from them (Bender and Siegel, 2004). These properties suggest that we are dealing with a syntactic rather than morphological phenomenon.

3.2 Analysis

Our analysis for head-initial modification consists of:

1. A lexical type hierarchy containing types that allow for head-initial constructions.
2. Grammar rules for head-initial modification and head-initial complementation.
3. A head feature `POSTHEAD` that is referenced by head-adjunct rules.

Figure 3 shows part of the type hierarchy of lexical signs, containing lexical items that modify nouns, postpositions and verbs, and which are divided into left-modifying and right-modifying items.

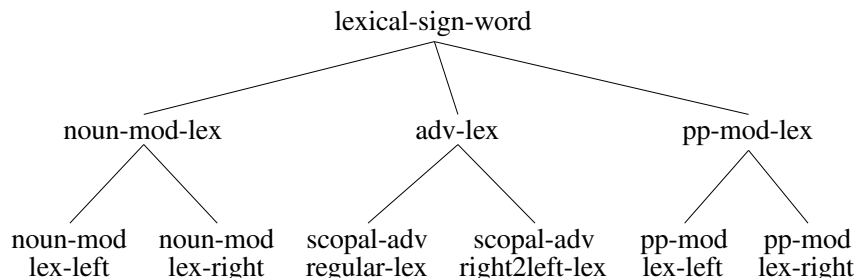

Figure 3: Partial hierarchy of lexical types for modifiers

The inventory of grammar rules contains rules for both head-initial and head-final complementation, which differ in the order of the daughters. The rules reference the `HEAD.POSTHEAD` value of the modifier daughter in order to constrain the distribution of lexical items across the constructions. `POSTHEAD` can be *left* or *right*, or can be left unspecified for those items that can modify in both directions.

¹⁰ The details of the analysis are presented in the appendix.

¹⁰We also use `POSTHEAD` for the selection of relative clause constructions, coordinated structures and the head selection of nominal compounds (see Radford, 1993 for criteria on head selection in nominal compounds).

4 Head-initial complementation

4.1 Data

We have found two clear cases of head-initial complementation, the first in number names and the second in numeral classifiers. In both cases, one optional argument follows the head.

We argue that number names like *ni hyaku juu* ‘210’ are head-medial on the basis of examples like (16) and (17). (16b) and (16c) each share one element in common with (16a). The examples in (17) show that the external distribution of these phrases differ.

- (16) a. *ni hyaku juu*
two hundred ten
- b. *go hyaku san*
five hundred three
- c. *ni sen san*
two thousand three
- (17) a. *roku sen ni hyaku juu*
six thousand two hundred ten
- b. *roku sen go hyaku san*
six thousand five hundred three
- c. **roku sen ni sen san*
six thousand two thousand three
- d. **roku sen go sen juu*
six thousand five thousand ten

Expressions with *hyaku* ((16a) and (16b)) have the same combinatoric potential. Expressions without *hyaku* differ. The other elements of (16) *ni* ‘two’ and *juu* ‘ten’ are not relevant. Thus, we take *hyaku* to be the head of (16). If we forget for the moment that Japanese is supposed to be head-final, this isn’t very surprising: English number names work the same way (see Smith, 1999). So do number names in another SVO language: Chinese, the source from which Japanese borrowed this system.

One might argue that this is actually a morphological process, in which case the head-medial structure is less surprising. However, Martin (1987) finds that while some local combinations within number names (e.g., the names for 11 through 19, 20, 30, 200, 300, etc.) form single phonological words, longer combinations made up of these pieces (such as *sanbyaku juuichi* ‘311’) show phrasal phonology.

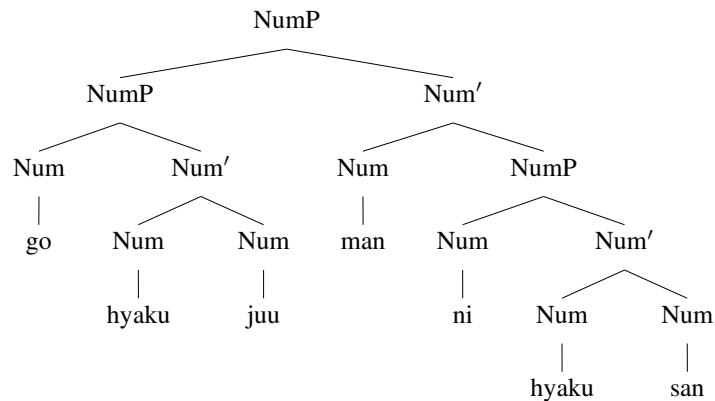

Figure 4: Center recursion in number name expressions

Moreover, number names show the sort of center recursion that distinguishes context-free languages from regular languages (see Figure 4). This kind of recursion is (to our knowledge) unattested elsewhere in morphology.

The analysis presented here was developed within the context of an application that takes text-based input. As such, it was most convenient to apply the phrasal analysis uniformly. A similar analysis could be developed that provides lexical entries for every combination that forms a phonological word. It would still involve head-initial structures: In a phrase like *sanbyaku juiichi*, the phonological words are *sanbyaku* ('three hundred') and *juiichi* ('eleven'). Following the same argumentation as above, *sanbyaku* (and within it, *hyaku*, meaning 'hundred') determines the distribution of the phrase within larger number names.

- (18) a. *issen* [sanbyaku juiichi]
 one thousand three hundred eleven
- b. **gohyaku* [sanbyaku juiichi]
 five hundred three hundred eleven]
- c. *gohyaku* [juuichi]
 five hundred eleven]

The second type of head-initial complementation involves numeral classifiers. All numeral classifiers combine with a number name to their left, but certain mensural numeral classifiers such as *nen* 'year' can also take the word *han* 'half' to their right (19). Syntactically, the numeral classifier determines the combinatorics of the phrase (being able to modify nouns, not being able to show up as the specifier of a larger number name). The presence or absence of *han* has no effect on the distribution. The numeral classifier is also in a better position to integrate the semantics of *han* than vice versa (Bender and Siegel, 2004).

(19) a. ni nen han
two years half

b. ni nen
two years

4.2 Analysis

Our analysis of both of these instances of head-initial complementation consists of:

1. Two head-complement rules, differing in the order of the daughters, and sensitive to the HEAD type of the head
2. A high-level distinction in the sub-types of *head* into *init-head* and *final-head*

The two head-complement rules are sensitive to the head type of their head daughter. Most head types are subtypes of *final-head*, giving the general pattern, while numeral classifiers and number names are given subtypes of *init-head*. The details of this analysis are presented in the appendix.

5 Conclusion

We believe that the rather peripheral exceptions noted here do not detract from the broad generalization that Japanese has a very strong tendency to be head-final. Rather, they illustrate once again the fact that languages seamlessly combine general tendencies with particular exceptions (cf. Fillmore et al., 1988). In order to build consistent grammars that scale up to ever larger fragments of the languages we wish to model (such as is required for practical applications), we require a framework that allows the statement of generalizations at varying degrees of granularity. Furthermore, we believe that the construction of broad-coverage precision grammars such as JACY in the context of applications which require robustness in the face of real-world language use provides a useful discovery procedure for many of the smaller generalizations and exceptional cases (cf. Baldwin et al., 2004)).

Appendix: Rules and types

In this appendix, we present the details of the rules and types used to implement these analyses in the JACY grammar. Complete details can be found by downloading JACY.¹¹ The basic idea is simple: Separate head-complement and head-adjunct rules for each order¹² which are keyed to particular features on one of the daughters: the adjunct in head-adjunct constructions and the head in head-complement

¹¹From <http://www.dfki.de/siegel/grammar-download/JACYgrammar.html>.

¹²The formalism we work with does not separate ID and LP rules.

constructions. We believe that there are many possible ways of representing the basic claims in this paper. This particular analysis has been integrated into the broad-coverage grammar and tested against corpus data. Thus, we know that it is consistent with a significant fragment of the language.

Head-Initial Modification

As described above, there are three components to this analysis: a lexical type hierarchy (see Figure 3) which allows for head-initial modification, head-initial (as well as head-final) versions of the relevant modifier rules, and a feature `POSTHEAD` which the rules reference to constrain the distribution of the modifiers.

Thus, head-initial modifier rules (scopal or intersective) bear these constraints, where the feature `ARGS` encodes the daughters of the rule and the order in which they appear:

$$(20) \left[\begin{array}{ll} \text{HEAD-DTR} & \boxed{1} \\ \text{NON-HEAD-DTR} & \boxed{2} \left[\dots \text{CAT.HEAD.POSTHEAD } \textit{right} \right] \\ \text{ARGS} & \langle \boxed{1}, \boxed{2} \rangle \end{array} \right]$$

Modifiers of type *pp-mod-lex-right*, etc., are constrained to be [`POSTHEAD right`], and are compatible with head-initial modifier rules. In contrast, *pp-mod-lex-left*, etc., are [`POSTHEAD left`] are thus incompatible with head-initial modifier rules. In principle, modifiers could be underspecified for `POSTHEAD`, thus appearing on either side. Our lexicon does not currently contain any such modifiers.¹³

Head-Initial Complementation

The analysis of head-initial complementation again involves two rules, and a means of restricting heads to one or the other. In this case, we do not posit an additional feature, but instead take advantage of the type hierarchy and posit a split between initial heads and final heads. Most head types inherit from *final_head*, including *noun-or-case-p_head* (subsuming nouns and the case particles), *verb_head*, and *p_head*, for the contentful post-positions. The two subtypes of *init_head* are *int_head* (for number names) and *num-cl_head* (for numeral classifiers). The latter point is a bit subtle: The only numeral classifiers that take complements at all are those that can appear with *han* (as a complement).¹⁴

¹³It might appear that numeral classifiers would constitute a case of modifiers attaching either to the left or the right of their heads. However, in pre-head uses of numeral classifiers there is always an intervening *no* (genitive) particle. We treat this particle as a head which selects for a numeral classifier phrase and mediates the modification of the noun by the numeral classifier. For details, see Bender and Siegel, 2004.

¹⁴We have actually found it convenient to posit one more kind of numeral classifier which takes a complement: namely currency symbols such as '\$', which appear to the left of a numerical expression but otherwise function syntactically and semantically like currency words such as *doru* and *en*, which appear to the right of a number name. Most numeral classifiers select their dependent number name

As the classification into *final_head* and *init_head* is only referenced by the head-complement rules, it is simplest to make them all *init_head*.

The following constraints on the two head-complement rules capture the necessary contrast:

(21) a. head-complement-head-final-rule:

$$\left[\begin{array}{l} \text{HEAD-DTR } \boxed{1} \left[\text{SYNSEM.LOCAL.CAT.HEAD } \textit{final_head} \right] \\ \text{NON-HEAD-DTR } \boxed{2} \\ \text{ARGS } \langle \boxed{2}, \boxed{1} \rangle \end{array} \right]$$

b. head-complement-head-initial-rule:

$$\left[\begin{array}{l} \text{HEAD-DTR } \boxed{1} \left[\text{SYNSEM.LOCAL.CAT.HEAD } \textit{init_head} \right] \\ \text{NON-HEAD-DTR } \boxed{2} \\ \text{ARGS } \langle \boxed{1}, \boxed{2} \rangle \end{array} \right]$$

The ordering constraints relating HEAD-DTR, NON-HEAD-DTR, and ARGS are inherited from a supertype that is also applicable to the head-modifier cases.

In our current implementation, there are no head types which are indeterminate between *init_head* and *final_head*. All head types inherit from exactly one of these. It would of course be possible to cross-classify the ordering dimension with the part of speech dimension, should this be necessary, if some elements of a certain head type preceded their complements and others followed or if all elements of some head type could appear in either order with respect to their complements. Our investigations so far suggest that this is not the case for Japanese. It might be relevant for another language with relatively free order in general, but with some heads showing a more fixed order.

References

Baldwin, Timothy, Beavers, John, Bender, Emily M., Flickinger, Dan, Kim, Ara and Oepen, Stephan. 2004. Beauty and the Beast: What Running a Broad-Coverage Precision Grammar Over the BNC Taught Us about the Grammar — and the Corpus, Paper presented at the International Conference on Linguistic Evidence: Empirical, Theoretical, and Computational Perspectives, Tübingen, Germany.

Bender, Emily M., Flickinger, Dan and Oepen, Stephan. 2002. The Grammar Matrix: An Open-Source Starter-Kit for the Rapid Development of Cross-Linguistically Consistent Broad-Coverage Precision Grammars. In John Carroll,

as a specifier. Currency symbols select their dependent number name as a complement. As the complement appears after the head in this case, it is consistent with making all numeral classifiers be *init_head*. However, this pattern is strictly a phenomenon of the written language: when such strings are read aloud, the current symbol is pronounced as a currency word after the number name. Therefore, the status of this pattern with respect to the points made in this paper is murky at best.

- Nelleke Oostdijk and Richard Sutcliffe (eds.), *Proceedings of the Workshop on Grammar Engineering and Evaluation at the 19th International Conference on Computational Linguistics*, pages 8–14, Taipei, Taiwan.
- Bender, Emily M. and Kathol, Andreas. In press. Constructional Effects of *Just Because ... Doesn't Mean ...*. In *BLS27*.
- Bender, Emily M. and Siegel, Melanie. 2004. Implementing the Syntax of Japanese Numeral Classifiers. In *Proceedings of IJCNLP-04*.
- Borsley, Robert D. 1993. Heads in HPSG. In Greville Corbett, N. Fraser and S. McGlashan (eds.), *Heads in Grammatical Theory*, pages 186–203, Cambridge: Cambridge University Press.
- Copestake, Ann, Flickinger, Daniel P. and Sag, Carl Pollard Ivan A. 2003. Minimal Recursion Semantics. An Introduction.
- Fillmore, Charles J., Kay, Paul and O'Connor, Mary Catherine. 1988. Regularity and Idiomaticity in Grammatical Constructions: The Case of Let Alone. *Language* 64(3), 501–538.
- Gunji, Takao. 1987. *Japanese Phrase Structure Grammar*. Dordrecht: Reidel.
- Kageyama, Taro. 2001. Word Plus: The Intersection of Words and Phrases. In J. v.d. Weijer and T. Nishihara (eds.), *Issues in Japanese Phonology and Morphology*, pages 245–276, Mouton de Gruyter.
- Makino, Seiichi and Tsutsui, Michio. 1986. *A Dictionary of Basic Japanese Grammar*. Tokyo: The Japan Times.
- Martin, Samuel E. 1987. *A Reference Grammar of Japanese*. Tokyo: Charles E. Tuttle Company, second edition.
- Matsumoto, Y., Kitauchi, A., Yamashita, T., Hirano, Y., Matsuda, H., Takaoka, K. and Asahara, M. 2000. Morphological Analysis System ChaSen version 2.2.1 Manual.
- Oepen, Stephan, Bender, Emily M., Callmeier, Ulrich, Flickinger, Dan and Siegel, Melanie. 2002. Parallel Distributed Grammar Engineering for Practical Applications. In *Proceedings of the Workshop on Grammar Engineering and Evaluation, COLING 2002*, Taipei, Taiwan.
- Pollard, Carl and Sag, Ivan A. 1994. *Head-Driven Phrase Structure Grammar*. Studies in Contemporary Linguistics, Chicago, IL and Stanford, CA: The University of Chicago Press and CSLI Publications.
- Radford, Andrew. 1993. Head-Hunting: On the Trail of the Nominal Janus. In Greville Corbett, N. Fraser and S. McGlashan (eds.), *Heads in Grammatical Theory*, pages 73–113, Cambridge: Cambridge University Press.

- Sag, Ivan A., Wasow, Thomas and Bender, Emily M. 2003. *Syntactic Theory: A Formal Introduction*. Stanford, CA: CSLI, second edition.
- Shibatani, Masayoshi and Kageyama, Taro. 1988. Word Formation in a Modular Theory of Grammar: Postsyntactic Compounds in Japanese. *Language* 64, 451–484.
- Siegel, Melanie. 1999. The Syntactic Processing of Particles in Japanese Spoken Language. In Jhing-Fa Wang and Chung-Hsien Wu (eds.), *Proceedings of the 13th Pacific Asia Conference on Language, Information and Computation*, Taipei, Taiwan.
- Siegel, Melanie. 2000. HPSG Analysis of Japanese. In Wolfgang Wahlster (ed.), *VerbMobil: Foundations of Speech-to-Speech Translation*, Berlin: Springer.
- Smith, Jeffrey D. 1999. English Number Names in HPSG. In Gert Webelhuth, Jean-Pierre Koenig and Andreas Kathol (eds.), *Lexical and Constructional Aspects of Linguistic Explanation*, pages 145–160, Stanford, CA: CSLI.
- Uszkoreit, Hans, Callmeier, Ulrich, Eisele, Andreas, Schäfer, Ulrich, Siegel, Melanie and Uszkoreit, Jakob. 2004. Hybrid Robust Deep and Shallow Semantic Processing for Creativity Support in Document Production. In *Proceedings of KONVENS 2004*, Vienna, Austria.
- Zwicky, Arnold M. 1993. Heads, Bases, and Functors. In Greville C. Corbett, Norman M. Fraser and Scott McGlashan (eds.), *Heads in Grammatical Theory*, pages 292–315, Cambridge: Cambridge University Press.

License to COLL: How to bind bound words and readings to their contexts

Jan-Philipp Soehn 

University of Jena

Proceedings of the 11th International Conference on
Head-Driven Phrase Structure Grammar

Center for Computational Linguistics, Katholieke Universiteit Leuven

Stefan Müller (Editor)

2004

Stanford, CA: CSLI Publications

pages 261–273

Soehn, Jan-Philipp. 2004. License to COLL: How to bind bound words and readings to their contexts. In Stefan Müller (ed.), *Proceedings of the 11th International Conference on Head-Driven Phrase Structure Grammar, Center for Computational Linguistics, Katholieke Universiteit Leuven*, 261–273. Stanford, CA: CSLI Publications. DOI: 10.21248/hpsg.2004.15. 

Abstract

In this contribution we propose a new module for handling idioms and distributional idiosyncrasies. Based on the concept by Richter/Sailer (1999) the new feature COLL (context of lexical licensing) plays the central role in our approach. We provide a way to handle decomposable and nondecomposable idioms and idioms containing bound words. Our module guarantees the co-occurrence of all idiom parts and of bound word and licensing context, respectively.

A prerequisite for our analysis is a means to select for particular elements in the lexicon. We introduce another feature, LISTEME, which gives each lexical item its unique identifier and makes it possible to select for a particular lexical word or phrase.

Finally, we compare our proposal with alternative approaches and give some ideas regarding further applications beyond idiomaticity.

1 Motivation

Idioms are omnipresent in everyday language, enriching our communication with metaphoric imagery and fulfilling various communicative goals.

Nonetheless, they have been widely neglected by linguists developing grammar fragments. And even where an account for idioms has been given, most approaches have their shortcomings (cf. Riehemann, 2001, ch. 4).

In this contribution we want to focus on decomposable and non-decomposable idioms¹ and idioms containing bound words. We concentrate on technical aspects of the analysis and refrain from presenting detailed linguistic corpus data due to space limitations. By “idiom” we mean idiomatic expressions that do not form complete sentences as would be the case for e. g. *His bark is worse than his bite*.

(1) *make waves* (“cause trouble”)

(2) *spill the beans* (“divulge a secret”)

The expressions in (1) and (2) are instances of decomposable idioms, i. e. their meaning can be derived from the idiom parts. Note that idiom parts are not necessarily to be understood literally. In (1), e. g., we can attribute the meaning “cause” to *make* and “trouble” to *waves*. The idiomatic meaning of the whole idiom consists of the idiomatic meanings of its parts.

Where this is not the case, an idiom is non-decomposable: the meaning of the whole phrase has nothing to do with the meaning of the words the idiom consists of. Consider (3) and (4):

[†]The research to the paper was funded by the *Deutsche Forschungsgemeinschaft*. I am grateful to Stefan Müller, Christine Römer, Manfred Sailer, Adrian Simpson, the reviewers and the audience of HPSG'04 for comments and Michelle Wibraham for help with English.

¹Cf. Gibbs et al. (1989) or Nunberg et al. (1994) for this distinction.

(3) *saw logs* (“snore”)

(4) *shoot the breeze* (“chat”)

It is not clear how to assign the meaning “snore” to the words *saw* and *logs*, the same holds for “chat”.

Finally, we want to draw the attention to idioms comprising bound words or “cranberry words” (Aronoff, 1976). These are expressions which are highly collocationally restricted. Dobrovolskij (1988) compiled quite a lot of examples for German, Dutch and English.

(5) *to learn/do sth. by rote* (automatically, by heart)

(6) *to cock a snook* (to thumb the nose)

The underlined words are restricted to the given contexts. Sometimes there is some variation, as in *to lie/go/lay doggo* (Brit. slang; “to hide oneself”), but a free distribution is not possible. Such idioms can be either decomposable or non-decomposable.

2 Lexemes and Listemes

Before we present our analysis, we point out a way that enables us to select a specific word. This forms a prerequisite of our approach.

Idioms often consist of particular words which cannot be substituted by semantically equivalent terms. It seems in general that each word has a unique “identity” with an idiosyncratic behavior. The possibility to select a particular word would, thus, be a useful feature. Up to now, there has been a discussion about the necessity of having such kind of selection. One could argue that any data in question are to be handled as Constructions or collocations. But why impose such a “heavy thing” on an expression like *to furrow one’s brow*? Would it not be plausible that the verb *furrow* simply selects a word of the form *brow*? For perfect tense in German a main verb has to be combined with the right auxiliary (*haben/sein*; in HPSG with the attribute AUXF, cf. Heinz and Matiasek, 1994, p. 222). Here one does nothing other than to select a particular lexeme.

A mechanism for selection of lexical elements has to meet three requirements:

1. The information has to be locally available (below SYNSEM).
2. The information has to be available along the syntactic projection line.
3. The information must be identical for a pronoun and its antecedent.

Krenn and Erbach (1994) made an important contribution to idiom analysis within the HPSG framework. They suggested selecting particular lexemes via their feature LEXEME below CONTENT INDEX. This idea of having lexeme information

in the CONTENT is questionable. A lexeme combines phonetic, morphological, syntactic and semantic properties all together, not only semantic information. Besides, their approach had several technical shortcomings (cf. Soehn and Sailer, 2003): the locality principle for selection (Pollard and Sag, 1994, p. 23) was not implemented and there was not means for the LEXEME value to percolate. We therefore propose that the LEXEME approach has to be discarded.

A different concept that helps to distinguish between individual words is that of a listeme². As the concept holds the characteristic of listedness in a lexicon, we use it in our grammar to identify a particular word or phrase. Thus, we insert LISTEME into the feature geometry below CATEGORY, emphasizing the morpho-syntactic character of information. More precisely, we put it below HEAD. This has two consequences: firstly, it is available for selection, as a HEAD value is below SYNSEM. Secondly, the LISTEME value of a projection is the same as the one of the head, as all HEAD features “percolate” according to the HEAD-FEATURE-PRINCIPLE. For our *furrow*-example that means that a modified direct object *his heavy brow* still has the same LISTEME value as *brow* alone.

A third question to address is the handling of pronominalization. It is necessary that pronouns have the same LISTEME value as their antecedent.³ In Krenn and Erbach’s approach this was the major motivation of putting the LEXEME feature in the INDEX. To emulate this quality, we propose a constraint ensuring that each pronoun which is co-indexed with an antecedent takes over its LISTEME value. In the lexical entries of pronouns that value would be left underspecified in that way, that it consists of a disjunction of an identifying value (*she, her, etc.*) and a wildcard. In case of co-indexation the wildcard is identical to the LISTEME value of the antecedent and – by virtue of the constraint – becomes the actual and concrete LISTEME value of the pronoun. An informal description of such a pronoun constraint is illustrated in (7).

(7) PRONOUN-LISTEME-CONSTRAINT:

If a pronoun is co-indexed with an antecedent, it takes over the LISTEME value of that antecedent. Otherwise the LISTEME value of this pronoun is that of the other disjunct.

The value of LISTEME is an atomic sort as *brow, heavy, furrow, take, she* etc. In order to identify listemes for the same words having different meanings, we use numeric indices just as in a dictionary.

In summary, discarding the LEXEME approach, we propose a more adequate solution for the problem of selecting particular words, at least with respect to terminology, technical feasibility and the feature geometry. We introduce a feature LISTEME which is appropriate for the sort *head* taking atomic sorts as its value.

²This term has been introduced by (Di Sciullo and Williams, 1988, p. 1) for a sign that is listed in the lexicon.

³E. g. in the phrase “*He furrowed it.*” the pronoun has the same LISTEME value as its antecedent, satisfying the subcategorizational requirement of the verb.

3 Licensing Contexts

Getting to the analysis, we have to define a second attribute in the feature geometry. We declare objects of sort *sign* to bear a list-valued feature *COLL* (Context Of Lexical Licensing), first introduced by Richter and Sailer (1999). The *COLL* list may contain objects of sort *barrier*. These *barriers* are particular nodes in the syntactic configuration, like XPs, complete clauses or utterances (a complete clause with an illocutionary force). The concept of barriers is borrowed from the tradition of generative grammar, where these form boundaries for government and binding principles. We avail ourselves of this concept and use similar barriers to restrict the range of influence of the *COLL* feature.

barrier objects have an attribute *LOCAL-LICENSER* (*LOC-LIC*) which has a value of sort *local*. In the lexical entry of an idiomatic word one can thus specify a *barrier* on its *COLL* list with a specific *local* configuration. Subsorts of *barrier* are illustrated in figure 1: *complete-clause*, *utterance*, *np*, *vp* and *pp*. The subsorts of barrier correspond to nodes in the syntactic tree with particular properties. The relations depicted in figure 2 identify the nodes which relate to the subsorts of *barrier*.⁴

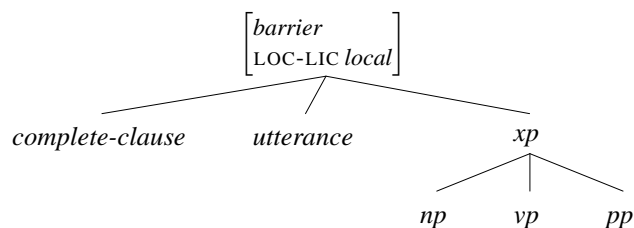

Figure 1: Sort hierarchy for *barrier*

The *LICENSING-PRINCIPLE* (informally in 8) makes sure that if there is a barrier specified on a word's *COLL* list, there is an actual barrier in the phrase our word occurs in. This barrier must fulfill the *local* requirements and it has to be minimal, i. e., there is no other potential barrier of the same kind between the word and the actual barrier.

(8) *LICENSING-PRINCIPLE* (LIP):

For each *barrier* object on the *COLL* list of a sign x and for each phrase z :
 the *LOCAL* value of z is identical with the *LOC-LIC* value,
 iff z dominates x , z can be identified as the barrier specified and z dominates
 no sign y which in turn dominates x and forms an equivalent barrier.

In this principle there are three conditions to be satisfied. The first one is simply that there must be a domination relation between the phrase z and the idiomatic element x . The second condition, that a particular barrier can be identified, means

⁴Cf. (Richter, 1997, pp. 68f) for the *STATUS* feature.

$$\begin{aligned}
& \forall \mathbb{I} \left(\text{is_utterance}(\mathbb{I}) \leftrightarrow \left[\begin{array}{l} \mathbb{I} \left[\begin{array}{l} \text{unembedded-phrase} \\ \text{STATUS } \textit{complete} \\ \text{SS} \left[\begin{array}{l} \text{LOC CAT} \left[\begin{array}{l} \text{HEAD } \textit{verb} \\ \text{SUBCAT } \textit{elist} \end{array} \right] \\ \text{ILLOCATION } \textit{illocution} \end{array} \right] \end{array} \right] \right] \right) \\
& \forall \mathbb{I} \left(\text{is_complete-clause}(\mathbb{I}) \leftrightarrow \left[\begin{array}{l} \mathbb{I} \left[\begin{array}{l} \text{phrase} \\ \text{STATUS } \textit{complete} \\ \text{SS} \left[\begin{array}{l} \text{LOC CAT} \left[\begin{array}{l} \text{HEAD } \textit{verb} \\ \text{SUBCAT } \textit{elist} \end{array} \right] \end{array} \right] \end{array} \right] \right] \right) \\
& \forall \mathbb{I} \left(\text{is_vp}(\mathbb{I}) \leftrightarrow \left[\begin{array}{l} \mathbb{I} \left[\begin{array}{l} \text{phrase} \\ \text{STATUS } \textit{incomplete} \\ \text{SS} \left[\begin{array}{l} \text{LOC CAT} \left[\begin{array}{l} \text{HEAD } \textit{verb} \\ \text{SUBCAT } \textit{nelist} \end{array} \right] \end{array} \right] \end{array} \right] \right] \right) \\
& \forall \mathbb{I} \left(\text{is_np}(\mathbb{I}) \leftrightarrow \left[\begin{array}{l} \mathbb{I} \left[\begin{array}{l} \text{embedded-phrase} \\ \text{STATUS } \textit{incomplete} \\ \text{SS} \left[\begin{array}{l} \text{LOC CAT} \left[\begin{array}{l} \text{HEAD } \textit{noun} \\ \text{SUBCAT } \textit{elist} \end{array} \right] \end{array} \right] \end{array} \right] \right] \right) \\
& \forall \mathbb{I} \left(\text{is_pp}(\mathbb{I}) \leftrightarrow \left[\begin{array}{l} \mathbb{I} \left[\begin{array}{l} \text{embedded-phrase} \\ \text{STATUS } \textit{incomplete} \\ \text{SS} \left[\begin{array}{l} \text{LOC CAT} \left[\begin{array}{l} \text{HEAD } \textit{prep} \\ \text{SUBCAT } \textit{elist} \end{array} \right] \end{array} \right] \end{array} \right] \right] \right)
\end{aligned}$$

Figure 2: Relations for *barrier*-subsorts

that one of the relations *is_vp*, *is_complete_clause*, etc. must hold. By the third condition we exclude the case where there is another phrase *y* between *z* and *x* being also a possible barrier. Thus, *z* is always the minimal one.

Hence, a word for which a barrier is defined cannot occur elsewhere; its distribution is already specified in the lexical entry.

This concludes the description of technical requirements for our approach to idioms. Note that we have defined quite a small number of new sorts, relations and attributes to be included in the signature. All idiosyncratic information comes from the lexicon, as we will see in the next section.

3.1 Decomposable Idioms

Let us show how a decomposable idiom can be analysed with our proposal. Take for instance the idiom in (1) *make waves*⁵. We can assign the meanings “cause” and “trouble” to *make* and *waves* and assume that there are two lexical entries for the idiomatic usage of these words.⁶

The idiomatic *make* subcategorizes for a plural noun with the word form *wave* (the idiomatic version) creating a VP with the meaning “cause trouble”.

$$(9) \left[\text{CAT} \left[\begin{array}{l} \text{HEAD} [\text{LISTEME } make_3] \\ \text{SUBCAT} \langle \text{NP}, \left[\text{LOC} \left[\begin{array}{l} \text{CAT HEAD} [\textit{noun}] \\ \text{LISTEME } wave_2 \end{array} \right] \right] \rangle \end{array} \right] \right] \right]$$

*wave*₂ for its part bears a non-empty COLL list which looks as follows:

$$(10) \left[\text{COLL} \left\langle \left[\begin{array}{l} \text{LOC-LIC} \left[\text{CAT} \left[\begin{array}{l} \text{HEAD} [\textit{verb}] \\ \text{LISTEME } make_3 \end{array} \right] \right] \right] \right] \right\rangle \right]$$

The distribution of the idiomatic noun *waves* is restricted in that it must be the complement of idiomatic *make*. The LIP makes sure that the specified *vp* on the COLL list is identical to the actual VP containing *make* and *waves*. That would have the following semantics: $\lambda x. [\mathbf{waves''}(y)](\mathbf{make''}(x, y))$ ⁷. Defining the barrier as a VP correctly implies that passivization of this idiom is not possible.⁸

⁵as in “Italian film makes waves” from <http://news.bbc.co.uk/1/hi/entertainment/film/3171907.stm> (All weblinks were found by Google on 01-27-2004)

⁶Other paraphrases of the idiom are “call attention” or “attract interest”. We leave open the exact definition of the meaning and take “cause trouble” as example.

⁷In this contribution we do not go into details of semantics. Under CONTENT LF we give the logical form of the expression, using a double apostrophe to indicate an idiomatic meaning. Our approach is compatible with any semantic representation as e. g. MRS (cf. Copestake et al., 1998) or LRS (Richter and Sailer, 2003).

⁸Riehemann (ibid.) found 5 examples out of 243 (2%) where the idiom parts do not occur within the same VP. If one wants to account for those (including passivization and a relative clause) the barrier is simply to be set accordingly.

Our example *spill the beans*⁹ can be analysed analogously. As we assume regular syntactic composition to be in force, we predict that different specifiers (*some beans*) or modifications (as *some very compromising beans*) are grammatical.

A special case of the idiom not occurring in its canonical form is that of pronominal reference. In fact, pronominalization is quite hard to handle in idiom analysis. Cf. the following example:

- (11) *Eventually she spilled all the beans. But it took her a few days to spill them all.*¹⁰

Here the pronoun *them* refers back to the idiomatic *beans*. As described in section 2 a pronoun has the same LISTEME value as its antecedent, so *them* gets its correct meaning. This being the case, the subcategorization requirements of idiomatic *spill* in both clauses are satisfied. The antecedent of *them* in turn is licensed by its own COLL value stating that the idiomatic *beans* can only occur together with the verb *spill* in its idiomatic use. The barrier is a *complete-clause* which allows e. g. passive or relative constructions. Thus, our proposal can handle pronominalization data, too.

3.2 Bound Words

Now we come to bound words: The idiom in (5) *to learn sth. by rote*¹¹ contains a word that never occurs in other contexts than as a complement of a PP with head *by*. The idiom is decomposable: *rote* means something like “routine”. The relevant parts of its lexical entry can thus be stated as follows:

$$(12) \left[\begin{array}{l} \text{word} \\ \text{PHON} \langle \text{rote} \rangle \\ \text{SS LOC} \left[\begin{array}{l} \text{CAT} \left[\begin{array}{l} \text{HEAD} \left[\begin{array}{l} \text{noun} \\ \text{LISTEME } \textit{rote} \end{array} \right] \\ \text{SUBCAT } \textit{e-list} \end{array} \right] \\ \text{CONT LF } \lambda x \lambda Q. \exists x (\textit{rote}'(x) \wedge Q(x)) \end{array} \right] \\ \text{COLL} \left\langle \begin{array}{l} \textit{pp} \\ \text{LOC-LIC} \left[\begin{array}{l} \text{CAT HEAD LISTEME } \textit{by} \\ \text{CONT LF } \dots \exists x (\textit{rote}'(x) \wedge \textit{by}'(x, e)) \dots \end{array} \right] \end{array} \right\rangle \end{array} \right]$$

By defining the CONTENT value of the barrier *pp* we prevent a modification of *rote*, which would be ungrammatical. The PP can modify any verb, allowing the occurrence of (*know, learn, sing, do,...*) *sth. by rote*.

To account for the example in (6), the lexical entry of *snook* requires a *vp* barrier with an appropriate LISTEME value of the head, as seen for the idiom *make waves*. We can restrict the distribution of these bound words in the same way as we handle idiomatic words contained in a decomposable idiom.

⁹as in “Tom Cruise has spilled the beans on Nicole Kidman’s relationship with US musician Lenny Kravitz.” from <http://www.smh.com.au/articles/2003/11/29/1070081589377.html?from=storyrhs>

¹⁰(Riehemann, 2001, p. 207)

¹¹as in “Students forced to learn history by rote” from http://www.shanland.org/Political/News_2002/students_forced_to_learn_history.htm

3.3 Non-decomposable Idioms

For idioms that have a non-decomposable meaning we define phrasal lexical entries (PLE), according to Sailer (2003) and following the idea of Gazdar et al. (1985). PLEs are lexical entries for syntactically complex expressions. Thus, they have properties of both words and phrases. As words, they are licensed by their lexical entry. As phrases, lexical rules cannot apply to them and syntactic operations like topicalization can be excluded by defining structural requirements in their DTRS attribute. According to standard HPSG assumptions we adopt Immediate Dominance Schemas that license ordinary phrasal signs. In order to exclude the application of ID-Schemas to a phrase licensed by a PLE we can redefine the ID-PRINCIPLE in the following way:

$$(13) \left[\begin{array}{l} \textit{phrase} \\ \text{COLL } e\text{-list} \end{array} \right] \rightarrow \left(\begin{array}{l} \text{HEAD-COMPLEMENT-SCHEMA} \vee \\ \text{HEAD-ADJUNCT-SCHEMA} \vee \\ \text{HEAD-MARKER-SCHEMA} \vee \\ \text{HEAD-FILLER-SCHEMA} \end{array} \right)$$

Accordingly, we have to change all other principles of grammar that are concerned with regular combination of signs in such a way that they only apply to phrases bearing an empty COLL list. This can simply be done by adding a line in the antecedent (remember that all principles are formulated as implications) stating [COLL *e-list*].

In order to specify which lexical entries must have an empty COLL list, we introduce subsorts of *listeme*, namely *coll_listeme* and *no_coll_listeme*, and make the following constraint:

$$(14) \left[\begin{array}{l} \textit{sign} \\ \text{SS LOC CAT HEAD LISTEME } no_coll_listeme \end{array} \right] \rightarrow [\text{COLL } e\text{list}]$$

Note that all lexical entries have different values of LISTEME and, conversely, the set of all LISTEME values covers the entirety of lexical entries.

We have now made a distinction between regular phrasal signs which have an empty COLL list and non-regular or idiomatic phrases having a non-empty COLL list. Thus, in a PLE of an idiom like (3) *saw logs*¹² we define its COLL list as non-empty. Besides, this idiom cannot be passivized without losing its idiomatic reading. Passivization is already excluded by the nature of the PLE itself: an object in accusative case is required and thus, *logs* can never occur as the subject.

¹²as in “Two young boys stand by their mother’s bed while she saws logs in her sleep.” from http://www.collegestories.com/filmfrat/igby_goes_down.html

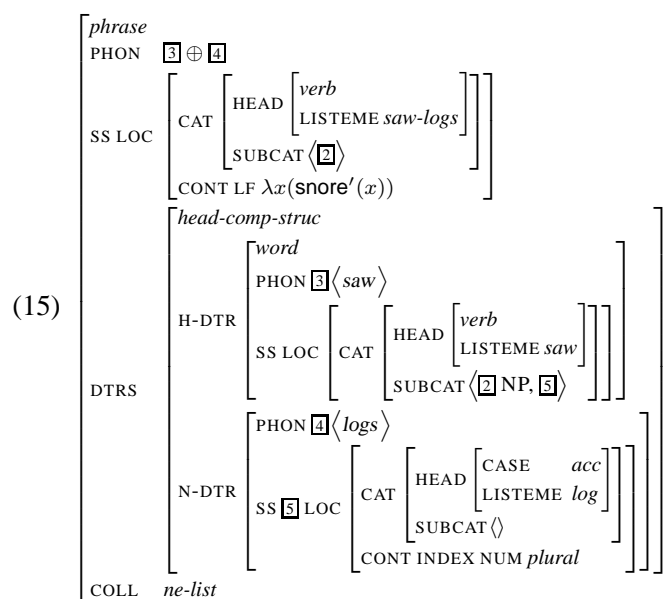

In defining a non-empty COLL value, we provide a unified way to treat decomposable and non-decomposable idioms, marking their quality of being idiomatic. Parts of decomposable idioms bear a non-empty COLL list, which restricts their occurrence to certain contexts. Nondecomposable idioms also have a non-empty COLL list, exempting them from regular syntactic and semantic principles.

In addition, the occurrence of nondecomposable idioms can be restricted to certain contexts via the same feature. This is important for idiomatic intensifiers, among others, like *as a sandboy* in *to be happy as a sandboy* or *as a kite* in *to be high as a kite*.

4 Alternative Analyses

4.1 A Different COLL Mechanism

The analysis we suggest here is an enhancement of a proposal by Richter and Sailer (1999). However, in Sailer (2003) the author described a variant of the COLL mechanism: In this thesis, the value of COLL is a singleton list that may contain a sign. That sign is the overall expression in which the idiomatic word occurs. Take for example the idiom *spill the beans*: in the lexical entry of the idiomatic word *beans* its COLL value is specified as a sign containing the semantic contributions of a definite article, the idiomatic word *spill* and *beans* itself in the right scopal relations. Sailer defines the so-called COLL-PRINCIPLE ensuring that the sign specified in a COLL list dominates the sign bearing that list. As a consequence, information of the overall utterance is available at lexical level and, conversely, local information is available on each node in the structure.

Thus, even though Sailer introduces only one new attribute, this approach is very unrestrictive and if one taps its full potential, nearly all grammatical phenom-

ena can be described, even if they have nothing to do with collocations. Selection, e. g., would only be a special case of a collocation. Because of this power and unrestrictedness, that version of COLL is to be met with criticism.

4.2 A Constructional Approach

Riehemann (2001) makes another concrete proposal for the analysis of idioms. She adopts many ideas of Construction Grammar and carries them forward to the HPSG framework. Her approach requires a complex machinery of new sorts and attributes to cover not only the amount of existing idioms but also their occurrences in different syntactic configurations. She has to assume, e. g., distinct subsorts of a *spill_beans_idiom_phrase* for the idiom occurring in different constructions (e. g. a *head-subject-phrase* or a *head-filler-structure*). Even if the existence of sorts for different constructions themselves is well established in Construction Grammar, it is questionable to assume different subclasses of linguistic signs, only because they contain idiomatic items in different syntactic structures. In other words, why assume different sorts for one single idiom only because it occurs in different constructions?

Moreover, Riehemann herself has to admit that her approach cannot handle cases of pronominal reference like (11), because idiomatic *spill* is not licensed as it seems to appear by itself and not within a *spill_beans_idiom_phrase*. In addition, Riehemann is unable to account for bound words, as she cannot constrain their distribution once she assumes lexical entries for them.

In summary, it seems to us that a lexical approach is to be preferred over a structural one. Nevertheless, her arguments in favor of a constructional analysis of non-decomposable idioms are convincing. Our counterpart to that are phrasal lexical entries which we assume for this kind of idiomatic expressions.

5 Prospects for a Modular Approach

We have proposed one way of analyzing idioms and similar phenomena of distributional idiosyncrasies. It can handle distributional characteristics of idiomatic words and even difficult cases like pronominalization.

We decided to take a word-level collocation-based account using the COLL feature. This approach is modular in two ways. Firstly, the barriers can be adjusted “vertically” according to the range (XP, complete clause or utterance) needed for a particular idiomatic expression. Secondly, by the LOC-LIC feature we can specify any characteristics within the local information. We could now go on and define other attributes of *barrier* like PHON-LIC to define any requirements of the phonetic string of that barrier. In that way our approach is also horizontally modular as one can specify objects that are on different levels in the sign-hierarchy (*sign*, *phonstring*, *local* etc.).

An application of such a PHON-LIC feature would be the modelling of occurrence restrictions of the English indefinite article *an*. This phenomenon is discussed by Asudeh and Klein (2002) together with other cases of sandhi. The authors integrate phonological shape conditions of the context in the element's lexical entry. Instead of their new feature PHONOLOGICAL-CONTEXT, we can use our COLL approach and define the lexical entry of *an* as follows:

$$(16) \left[\text{COLL} \left\langle \left[\begin{array}{l} np \\ \text{PHON-LIC} \langle \text{ən} \rangle \oplus (\text{æ} \vee \text{ʌ} \vee \text{e} \vee \text{ə} \vee \dots) \end{array} \right] \right\rangle \right]$$

The PHON-LIC value of the barrier *np* on the COLL list is the phonetic string *an* plus a phonetically realized vowel.

Thus, with a quite general approach to idioms using the COLL feature, we can handle very particular phenomena, too. The COLL module is described more extensively in Soehn (In prep.).

To explore the possibilities that our approach holds may be a matter of further research.

References

- Aronoff, Mark. 1976. *Word Formation in Generative Grammar*. MIT Press, Cambridge MA, third edition, linguistic Inquiry Monographs.
- Asudeh, Ash and Klein, Ewan. 2002. Shape Conditions and Phonological Context. In Frank van Eynde, Lars Hellan and Dorothee Beermann (eds.), *Proceedings of the 8th International HPSG Conference*, pages 20–30, CSLI Publications, <http://csli-publications.stanford.edu/HPSG/2/>.
- Copestake, Ann, Flickinger, Daniel, Pollard, Carl and Sag, Ivan A. 1998. *Minimal Recursion Semantics: An Introduction*. Stanford, <ftp://ftp-csli.stanford.edu/linguistics/sag/mrs.ps.gz>.
- Di Sciullo, Anna-Maria and Williams, Edwin. 1988. *On the Definition of Word*. Linguistic Inquiry Monographs, MIT Press, Cambridge, Mass, second edition.
- Dobrovolskij, Dmitrij. 1988. *Phraseologie als Objekt der Universalienlinguistik*. VEB Verlag Enzyklopädie Leipzig, linguistische Studien.
- Gazdar, Gerald, Klein, Ewan, Pullum, Geoffrey and Sag, Ivan. 1985. *Generalized Phrase Structure Grammar*. Cambridge, Mass.: Harvard University Press.
- Heinz, W. and Matiasek, J. 1994. Argument Structure and Case Assignment in German. In John Nerbonne, Klaus Netter and Carl Pollard (eds.), *German in Head-Driven Phrase Structure Grammar*, pages 199–236, CSLI Publications, lecture Notes 46.

- Krenn, Brigitte and Erbach, Gregor. 1994. Idioms and Support Verb Constructions. In John Nerbonne, Klaus Netter and Carl Pollard (eds.), *German in Head-Driven Phrase Structure Grammar*, pages 365–396, CSLI Publications, lecture Notes 46.
- Nunberg, Geoffrey, Sag, Ivan A. and Wasow, Thomas. 1994. Idioms. *Language* 70, 491–538.
- Pollard, Carl and Sag, Ivan A. 1994. *Head-Driven Phrase Structure Grammar*. Stanford University: CSLI/The University of Chicago Press.
- Raymond W. Gibbs, JR., Nayak, Nandini P., Bolton, John L. and Keppel, Melissa E. 1989. Speakers' assumptions about the lexical flexibility of idioms. *Memory & Cognition* 17(1), 58–68.
- Richter, Frank. 1997. Die Satzstruktur des Deutschen und die Behandlung langer Abhängigkeiten in einer Linearisierungsgrammatik. Formale Grundlagen und Implementierung in einem HPSG-Fragment. In Erhard Hinrichs, Detmar Meurers, Frank Richter, Manfred Sailer and Heike Winhart (eds.), *Ein HPSG-Fragment des Deutschen, Teil 1: Theorie*, Arbeitspapiere des SFB 340, No. 95, pages 13–187, Universität Tübingen.
- Richter, Frank and Sailer, Manfred. 1999. LF Conditions on Expressions of Ty2: An HPSG Analysis of Negative Concord in Polish. In Robert D. Borsley and Adam Przepiórkowski (eds.), *Slavic in Head-Driven Phrase Structure Grammar*, pages 247–282, Stanford: CSLI Publications.
- Richter, Frank and Sailer, Manfred. 2003. Basic Concepts of Lexical Resource Semantics., lecture notes for the course on Constraint-based Combinatorial Semantics at ESSLLI 2003, Vienna. To appear in the series of the Kurt Gödel Society, Vienna.
- Riehemann, Susanne Z. 2001. *A Constructional Approach to Idioms and Word Formation*. PhD Thesis, Stanford University, Stanford, CA.
- Sailer, Manfred. 2003. Combinatorial Semantics and Idiomatic Expressions in Head-Driven Phrase Structure Grammar. Phil. Dissertation (2000). Arbeitspapiere des SFB 340. 161, Eberhard-Karls-Universität Tübingen.
- Soehn, Jan-Philipp (In prep.). “Über Bären dienste und erstaunte Bauklötze”. *Idiome ohne freie Lesart in der HPSG*. PhD Thesis, Friedrich-Schiller-Universität Jena.
- Soehn, Jan-Philipp and Sailer, Manfred. 2003. At First Blush on Tenterhooks. About Selectional Restrictions Imposed by Nonheads. In Gerhard Jäger, Paola Monachesi, Gerald Penn and Shuly Wintner (eds.), *Proceedings of Formal Grammar 2003*, pages 149–161.

An HPSG analysis of Persian relative clauses

Mehran A. Taghvaipour

University of Essex

Proceedings of the 11th International Conference on
Head-Driven Phrase Structure Grammar

Center for Computational Linguistics, Katholieke Universiteit Leuven

Stefan Müller (Editor)

2004

Stanford, CA: CSLI Publications

pages 274–293

Taghvaipour, Mehran A. 2004. An HPSG analysis of Persian relative clauses. In Stefan Müller (ed.), *Proceedings of the 11th International Conference on Head-Driven Phrase Structure Grammar*, Center for Computational Linguistics, Katholieke Universiteit Leuven, 274–293. Stanford, CA: CSLI Publications. DOI: 10.21248/hpsg.2004.16.



Abstract

Relative clauses (RCs) in Persian are head-modifying constituents, all typically introduced by the invariant complementizer *ke*. Persian RCs are Unbounded Dependency Constructions (UDCs), containing either a gap or a resumptive pronoun (RP). In some positions only gaps are allowed, and in other positions only RPs. There are also some positions where both gaps and RPs are alternatively allowed. Illustrating the striking similarities between Persian gaps and RPs, I will provide an HPSG unified approach to take care of the dependency between the licensing structure and the gap/RP with a single mechanism, using only the SLASH feature. Similar to Pollard and Sag's (1994) approach to the bottom of the dependency, I will assume a special *sign* at the bottom. However, my *sign* may have a nonempty PHON value. I will introduce a feature called GAPTYPE which is a NONLOCAL feature whose value can be either *trace* or *rp*. I will introduce two constraints to capture the pattern of distribution of RPs and traces. At the top of the dependency, I will bind the nonempty SLASH at the complementizer point. I will propose a lexical entry for the complementizer *ke* that will account for the binding of SLASH by the feature BIND, which has a non-empty set as value.¹

1 Introduction

This paper presents an analysis for Persian restrictive relative clauses (RCs) in the Head-driven Phrase Structure Grammar (HPSG) framework. I will first provide some data and outline some general properties of the language, with a particular emphasis on RCs, and resumptive pronouns (RPs), their pattern of distribution, and their similarity with gaps in RC constructions. In Section 3, I will present my own analysis, which utilises only the SLASH feature (as opposed to Vaillette (2001), who uses two different NONLOCAL features). At the bottom of the dependency, I will assume a special *sign* that has a nonempty value for the SLASH feature. This special *sign* can be either a RP or a trace. I will introduce a feature called GAPTYPE which is a NONLOCAL feature whose value can be either *trace* or *rp*. I will introduce two constraints to capture the pattern of distribution of RPs and traces. At the top of the dependency, I will bind the non-empty SLASH at the complementizer point. I will propose a lexical entry for the complementizer *ke* that will account for the binding of SLASH by the feature BIND, which has a non-empty set as its value. Section 4 highlights some issues for further research and suggests some alternative approaches to the present analysis.

2 The Data

Persian is a null-subject verb-final language with SOV word order in declarative sentences and subordinate clauses. Example (1) represents a simple sentence in Persian.

¹ I am grateful to my supervisor, Bob Borsley, and two anonymous reviewers of HPSG 2004 for their constructive comments on an earlier version of this paper. I would also like to thank the audience of HPSG 2004.

(1)
 (mæn) ye doxtær daræm.
 (I) one daughter have-PRES-1sg
 ‘I have a daughter.’

Example (2) is another Persian sentence, containing a restrictive RC. Restrictive RCs in Persian are distinguished from their non-restrictive counterparts by comma intonation and the suffix *-i*, henceforth shown by -RES in gloss.

(2)
 zæn-i [ke mæn dust+daræm] inja nist.
 woman-RES COMP I like-PRES-1sg here NEG-
 be-3sg
 ‘The woman that I love is not here.’

Persian RCs are typically introduced by the complementizer *ke*. Ungrammatical example (3) illustrates that Persian does not allow *ke*-less RCs. This is unlike English, for example, which allows *that*-less relatives. See the English translation of (3).

(3)
 *zæn-i [Ø mæn dust+daræm] inja nist.
 woman-RES Ø I like-PRES-1sg here NEG-be-3sg
 ‘The woman I love is not here.’

The complementizer *ke* in Persian is invariant. That is, it does not agree with the noun (phrase) it follows. *Ke* is used regardless of the animacy, gender, function, or number of the noun modified by the RC. Examples in (4) illustrate invariant *ke* when the modified noun is in subject and object positions or in genitive case.

- (4)
- a. (relativized element in subject position)
- ... mærd-i ke shoma ra did...
 ...man-RES COMP you RA see-PAST-3sg
 ‘...the man who saw you...’
- b. (relativized element in object position)
- ... mærd-i ke shoma didid...
 ...man-RES COMP you see-PAST-3sg
 ‘...the man whom you saw...’

- c. (relativized element in genitive case)
 ... *mærd-i ke pirahænæš zærd æst ...*
 ...man-RES COMP shirt-his yellow be-PRES-3sg
 ...the man whose shirt is yellow ...

Personal pronouns can be used resumptively in Persian. That is, a personal pronoun is used where a gap might be expected. Example (5b) represents a Persian RC in which the pronoun *u*, ‘s/he’, is used resumptively.

- (5a)
mærd-i [ke ____ diruz molaqat kærðid] aqay-e Bayat bud.
 man-RES COMP Ø yesterday meet-PAST-2pl Mr. Bayat be-PAST-3sg
 ‘The man whom you met yesterday was Mr. Bayat.’

- (5b)
*mærd-i [ke **u** ra² diruz molaqat kærðid] aqay-e Bayat bud.*
 man-RES COMP **he** RA yesterday meet-PAST-2pl Mr. Bayat be-PAST-3sg
 ‘The man whom you met (***him**) yesterday was Mr. Bayat.’

Table 1 below shows the pattern of distribution of gaps and resumptive pronouns in Persian restrictive RCs. In some positions, only gaps are allowed. In other positions only resumptive pronouns are allowed. Both gaps and resumptive pronouns are possible in some other positions.

	Restrictive RCs			
	Subject	Direct Object	Genitive	Object of Prep.
Gap is allowed?	Yes	Yes	No	No
RP is Allowed?	No	Yes	Yes	Yes

TABLE 1: DISTRIBUTION OF GAPS AND RPS IN RESTRICTIVE RCS

As shown in Table 1, if the relativized position is subject, a resumptive pronoun cannot appear. Examples in (6) illustrate.

- (6a)
mærd-i ke ____ pirahæn-e zærd pušideh-æst
 man-RES COMP ____ shirt-EZ yellow wear-PRESPART-3sg
 ‘The man who is wearing a yellow shirt...’

² This particle (whose colloquial form is *ro*) is a specificity marker in Persian and is shown, henceforth, by RA in gloss. For detail discussion, see Karimi (1990) and Dabirmoghaddam (1990).

(6b)
 **mærd-i ke u pirahæn-e zærd pušideh æst*
 man-RES COMP he shirt-EZ yellow wear-PRESPART-3sg
 ‘The man who he is wearing a yellow shirt ...’

It is noteworthy, however, that some languages, e.g. Irish, only exclude resumptive pronouns from the highest subject position. They can freely appear in the subject position of embedded clauses. Example (7) represents an ungrammatical Irish sentence. Like (6b), the subject position in (7) is occupied by a resumptive pronoun and therefore the result is ungrammatical. Persian and Irish behave similarly here.

(7)
 **an fear a raibh sé breoite*
 the man COMP be-PAST he ill
 ‘the man that (he) was ill’

(McCloskey, 1990)

However, unlike the similar behaviour of Irish and Persian in the highest subject position, the two languages behave differently in embedded positions. Examples in (8), from (McCloskey, 1990), represent clauses containing embedded subjects in Persian and Irish, respectively. There is no difference in Persian if the subject is in embedded position. Simply, resumptive pronouns are not allowed in subject positions in Persian.

(8)
 a.
 **adres-i [ke mæn be doktor-i [ke u æli ra*
 address-RES COMP I to doctor-RES COMP he Ali RA

æmæel kærd dadæm qælət bud.]]
 operation-PAST-3sg do-give-PAST-1sg wrong be-PAST-3sg

‘The address that I gave to the doctor who (he) did an operation on Ali was wrong.’

b.
an t-ór seo archreid corr-dhuine go raibh se ann
 this gold COMP believed a few people COMP was it there
 ‘this gold that a few people believed (it) was there’

If the position relativized is object of preposition, the presence of a resumptive pronoun is obligatory; otherwise, the result will be ungrammatical as in (9b).

(9a)
mærd-i ke šoma diruz æz u pul gereftid ...
 man-RES COMP you yesterday from **he** money take-PAST-2pl
 ‘The man from whom you took money yesterday ...’

(9b)
 **mærd-i ke šoma diruz æz _____ pul gereftid ...*
 man-RES COMP you yesterday from _____ money took-2pl

It is worth mentioning here that ‘pied piping’ (Ross 1967) is not allowed in Persian RCs³. Examples in (10) illustrate.

(10a)
 ... *mærd-i ke be šoma pul dad ...*
 ...man-RES COMP to you money give-PAST-3sg...
 ‘...the man who gave money to you...’

(10b)
 **mærd-i be ke šoma pul dad...*
 man-RES to COMP you money give-PAST-3sg

Table 1 also shows that if the position relativized is that of the possessor, a resumptive pronoun must be present. This is contrasted in (11a) and (11b).

(11a)
mærd-i [ke pirahæn-e u zærd æst] ...
 man-RES COMP shirt-EZ **he** yellow be-PRES-3sg
 ‘The man whose shirt is yellow ...’

(11b)
 **mærd-i [ke pirahæn _____ zærd æst] ...*
 man-RES COMP shirt _____ yellow be-PRES-3sg

As for the direct object position, we saw earlier in examples (6a) and (6b) above that Persian allows both gaps and resumptive pronouns. Example (12), taken from Safavi (1994: 187), provides further evidence in this regard as both readings are grammatical.

³ This is, of course, a consequence of the fact that *ke* is a complementizer.

(12)

hušæŋg ketab-i ra [ke pesaræm (an ra) xarideh-bud] dozdid
Hushang book-RES RA COMP son-my (it RA) buy-PP-3sg stole-3sg
‘Hushang stole the book that my son had bought for me.’

Above, I have noted some differences between Persian gaps and RPs. I shall now highlight some similarities. I will provide below a variety of evidence in favour of this similarity from the following phenomena: (i) coordinate structures, (ii) parasitic gaps, (iii) crossover, and (iv) island constraints.

A strong argument in support of how similar resumptive pronouns and gaps are comes from coordinate structures. The examples in (13) show that if in unbounded dependency constructions, there is a gap in one conjunct of a coordinate structure, we cannot have an NP in the other.

(13a)

The man that I think Hobbs dislikes ____ and Rhodes hates _____

(13b)

*The man that I think Hobbs dislikes ____ and Rhodes hates Trumper

Data from Persian also show that this language is sensitive to the Coordinate Structure Constraint. The pair of sentences in (14) illustrates.

(14a)

mærd-i ke šoma ____ molaqat kærđid va ____ kolah be sær dašt
man-RES COMP you ____ visist-PAST-2pl and ____ hat wore-3sg
‘The man that you visited ____ and ____ was wearing a hat’

(14b)

**mærd-i ke šoma ____ molaqat kærđid va Yasmin kolah be+sær+dašt*
man-RES COMP you ____ visist-PAST-2pl and Yasmin hat wore-3sg
‘The man that you visited ____ and Yasmin was wearing a hat’

Although the above examples show that a gap in one conjunct cannot co-occur with an NP in the other, the example in (15) from Sells (cited in Vaillette, 2000) illustrates how it is possible to have a gap in one conjunct and a resumptive pronoun in the other in Hebrew.

(15)

kol profesor še dani roce le hazmin _____i aval lo maarix ?oto_i maspik
every prof. that Dani wants to-invite _____i but not esteems **him**_i enough
‘every professor that Dani wants to invite but doesn’t respect enough’

From Swedish, Engdahl (1985:8) provides additional data in support of this argument. Example (16) shows how clauses with resumptive pronouns can be conjoined with clauses with gaps in Swedish.

(16)

Det finns vissa ord (som) jag ofta träffar på ____i men inte
 There are certain words that I often meet ____i but not

minns hur de_i stavas.

remember how **they** are-spelled

‘There are certain words that I often come across but never remember how they are spelled.’

Examples (17a) to (17d) show how in Persian unbounded dependency constructions a resumptive pronoun can also be used with a gap in coordinate structures. In fact, in this language, it is possible to have gaps in both conjuncts, resumptive pronouns in both, or a gap in one conjunct and a resumptive pronoun in the other.

(17a)

mærd-i ke šoma ____ molaqat+kærdid va ____ kolah be+sær+dašt
 man-RES COMP you ____ visist-PAST-2pl and ____ hat wear-PAST-3sg

æli bud.

Ali be-PAST-3sg

‘The man that you visited ____ and ____ was wearing a hat was Ali.’

(17b)

mærd-i ke pirahænæš zærd bud və šoma be u ab
 man-RES COMP shirt-his yellow be-PAST-3sg and you to **him** water

dadid

give-PAST-2pl

æli

Ali

bud.

be-PAST-3sg

‘The man whose shirt was yellow and you gave him water was Ali.’

(17c)

mærd-i ke _____ pīrahæn-e zærd pušideh+bud væ shoma
man-RES COMP _____ shirt-EZ yellow wear-PRESPART-3sg and you

diruz az u pul qærz+gereftid Ali bud.
yesterday from **him** money borrow-PAST-2pl Ali be-
PAST-3sg

‘The man who was wearing a yellow shirt and you borrowed money from was Ali.’

(17d)

mærd-i ke shoma az u pul qærz+gereftid væ
man-RES COMP you from **him** money borrow-PAST-2pl and

_____ pīrahæn-e zærd pušideh+bud Ali bud.
_____ shirt-EZ yellow wear-PRESPART-3sg Ali be-PAST-3sg

‘The man who you borrowed money from and was wearing a yellow shirt was Ali.’

Another argument that supports the similarity of resumptive pronouns and gaps comes from parasitic gaps. A parasitic gap is a gap which is only possible because there is a ‘real’ gap in the same structure. English sentences (18a) and (18b) contain two gaps each. In (18a), the first gap is parasitic; while in (18b), the parasitic gap is the second.⁴

(18)

- a. Which man do you think stories about _____ really annoy _____?
b. Which book did he criticise _____ without reading _____?

The pair of sentences in (19) shows how other NPs cannot grammatically license the parasitic gaps in (18).

(19)

- a. *Which man do you think stories about _____ really annoy Kim?
b. *Which book did he criticise the introduction without reading _____?

However, despite Chomsky’s (1982) prediction that resumptive pronouns should not license parasitic gaps, Engdahl (1985:7) shows that this prediction seems to

⁴ This is now controversial. Levine and Sag (2003) argue that neither gap is really parasitic in an example like (18b), although the second gap is traditionally seen as parasitic.

be falsified by data like that in (20) below from Swedish. This example gives a well-formed RC containing a resumptive pronoun *han* and a parasitic gap in the adjunct clause, shown by *p*.

(20)

Det var den fången_i som läkarna inte kunde avgöra
 It was that prisoner that the-doctors not could decide

[som han_i verklingen var sjuk]
 if he really was ill

[utan att tala med p personligen].
 without to talk with ___ in person

Sells (1987: 266) also cites example (21) to show that, in Hebrew as well, resumptive pronouns can license parasitic gaps. In this example, the parasitic gap, inside the subject NP is licensed by a resumptive pronoun inside the VP.

(21)

rina hi ha'iša še [ha 'anašim še ani šixnati levaker ____i] [te'aru ota_i]
 Rina is the-woman_i that the-people that I convinced to-visit ____i described
her_i 'Rina is the woman that the people that I convinced to visit ___ described.'

Persian data also provide further evidence in support of the idea that resumptive pronouns, like gaps, can license parasitic gaps. Karimi (1999:705) cites examples (22a) and (22b) to illustrate this possibility. In (22a) there are two gaps, the second of which is parasitic. (22b) shows a sentence in which the second gap is still parasitic but it is licensed by the resumptive pronoun *un*.

(22a)

Kimea in ketab ro ghablaz in ke ___ bexuneh ___ be man dad.
 Kimea this book RA before this that ___ SUB-read-3sg ___ to me gave-3sg
 'Kimea gave me this book before reading (it).'

(22b)

Kimea in ketab ro ghablaz in ke unro bexuneh ___ be man dad.
 Kimea this book RA before this that it+RA SUB-read-3sg ___ to me gave-3sg
 'Kimea gave me this book before reading (it).'

In addition to coordinate constructions and parasitic gaps, crossover effect ⁵also provides further support for the similarity of Persian gaps and RPs. Examples in (23) show that Persian gaps are sensitive to crossover effects. Strong and weak crossover effects in Persian are illustrated in (23a) and (23b), respectively.

(23)

a. **Ki_i un_i fekr mikoneh ___ un kar ro kærd?*
 Who_i he_i think-PRES-3sg ___ that work RA did?
 ‘Who_i does he_i think did it?’

b. **Ki_i ra madæresh_i ___ dust dareh?*
 Who_i RA mother-**his_i** ___ love-PRES-3sg?
 ‘Who_i does his_i mother love?’

To see if resumptive pronouns, like gaps, exhibit crossover effects, McCloskey (1990) cites example (24) from Irish. This sentence is perfectly grammatical, apparently showing that resumptive pronouns in Irish are not subject to crossover effect.

(24)

Cé ar shil tú gur dhúirt sé go bpósfadh Máire é?
 Who COMP_{pro} thought you COMP said **he** COMP would-marry Mary **him**
 *‘Who_j did you think that he_j said that Mary would marry t_j?’

However, McCloskey (1990), Shlonsky (1992) and Vaillette (2000) all note that in examples like (24), where we have two pronouns and no gaps, there will normally be no reason why the leftmost or the highest pronoun should not be a resumptive one. In such cases, the other pronoun will be a normal (not resumptive) pronoun, which is simply coindexed with the first one.

⁵ Of course there is no actual crossover in a non-transformational framework. Essentially what is ruled out is a coindexed constituent between the top and the bottom of an unbounded dependency.

To show that resumptive pronouns are indeed sensitive to crossover effects, McCloskey (1990), Shlonsky (1992) and Vaillette (2000) provide examples in which the first or the highest pronoun is replaced by an epithet⁶. Epithets remove the ambiguity inherent in pronouns as they are not used resumptively.

Following this technique, I provide sentence (25) which shows that Persian resumptive pronouns, like gaps in this language, are sensitive to crossover effect.

(25)

**pesæri-i* [*ke æhmæq_i goft Mæryæm baš_i ærusi mikoneh*].
 boy-RES COMP idiot said-3sg Maryam with+**him** marry-PRES-3sg
 ‘The boy_i that the idiot_i said Maryam would marry him_i’

In (25), the epithet *æhmæq*, ‘idiot’ appears between the top of the dependency and the resumptive pronoun *š*, ‘him’. They are all co-indexed and the epithet, which is below the retrieval site of the dependency cannot bind the resumptive pronoun (in GB terms, the epithet c-commands the RP). Therefore, the result is ungrammatical.

Perhaps the most important support for the similarity of gaps and resumptive pronouns in Persian comes from the Island Constraints. Persian data shows that Persian resumptive pronouns, like gaps in this language, are sensitive to certain islands. Here, I will examine the Subject Condition, the Complex NP Constraint, and the Coordinate Structure Constraint.

Persian gaps are sensitive to the Subject Condition as illustrated in the pair of sentences in (26). In (26a), the subject is put in brackets and it acts like an island for unbounded dependencies as they cannot cross the boundary of the subject. For example, (26b) is ungrammatical because the question word is separated from the gap by the boundary of a subject NP.

(26a)

[*in ede’a ke Ali Hæmid ra dideh*] *Yasmin ra narahat kærd*.
 [this claim COMP Ali Hamid RA see-PP-3sg] Yasmin RA annoyed
 ‘The claim that Ali has seen Hamid annoyed Yasmin.’

(26b)

**ki* [*in ede’a ke Ali ___ dideh*] *Yasmin ra narahat kærd?*
 who [this claim that Ali ___ see-PP-3sg] Yasmin RA annoyed.
 ‘Who the claim that Ali has seen ___ annoyed Yasmin?’

⁶ By epithet, it is here meant an abusive word occurring in place of the name of a person or thing or a pronoun referring to such a name or thing.

The same constraint contributes to the ungrammaticality of (27b) below as the unbounded dependency crosses the boundary of the subject.

(27a)
mærd-i ra ke Ali _____ molaqat+kærd
 man-RES RA COMP Ali Ø meet-PAST-3sg
 ‘The man that Ali met ____.’

(27b)
 **mærd-i ra ke [in ede’a ke Ali __ molaqat+kærd] Yasmin ra narahat+kærd?*
 man-RES RA COMP[this claim that Ali __ see-PP-3sg] Yasmin RA annoyed.
 ‘The man the claim that Ali has seen ____ annoyed Yasmin?’

Borer (cited in Vaillette's (2000)) shows how resumptive pronouns in Hebrew are exempt from certain islands⁷. While (28) is ungrammatical with the gap, it is grammatical with the resumptive pronoun.

(28)
ha-yeled_i še dalya makira ?et ha-?iša še ?ohevet ?oto_i/ ______i*
 the-boy_i that Dalya knows ACC the-woman that loves **him_i**/* ______i
 ‘the boy that Dalya knows the woman who loves him’

Vaillette (2000) notes that there are languages (e.g. Igbo and Palauan) in which resumptive pronouns are also sensitive to island constraints. The following example from Persian shows that if we had a resumptive pronoun instead of the gap in (27c), the result would still be ungrammatical as shown in (29). This suggests that Persian resumptive pronouns, like gaps, are sensitive to the Subject Condition.

(29)
 mærd-i ke [in ede’a ke Ali **u ra molaqat+kærd] Yasmin ra narahat+kærd?*
 man-RES COMP[this claim that Ali **him** see-PP-3sg] Yasmin RA annoyed.
 ‘The man the claim that Ali has seen ____ annoyed Yasmin?’

This is where (30), which is equivalent of (27a) with a resumptive pronoun is grammatical.

(30)
*mærd-i ke Ali **u** ra molaqat+kærd*
 man-RES COMP Ali **him** RA meet-PAST-3sg
 ‘The man that Ali met ***him**.’

Another island constraint that applies to Persian is Complex NP Constraint. Borsley (1999:207) notes that “a *wh*-dependency cannot cross the boundary of a

⁷ It is the same in Irish, and probably in lots of languages.

clause and the NP that contains it.” Miremadi (1997: 197) cites the pair of sentences in (31) to illustrate the violation of this constraint in Persian. The complex NP is put in brackets.

(31a)

[*in ede'a ke Hassan æz Ali dær dærsæš piši*
 this claim COMP Hassan than Ali in study-his ahead

gerefteh+æst *baværkærdæni* *nist*
 achieve-PRES PERF-3sg believable NEG-be-PRES-3sg
 ‘The claim that Hassan has achieved more than Ali in his studies is not believable.’

(31b)

**che-kæsi in ede'a ke Hassan æz ___ dær*
 who this claim that Hassan than ___ in

dærsæš piši gerefteh+æst baværkærdæni nist.
 study-his ahead achieve believable NEG-be-PRES-3sg

Again, like gaps, resumptive pronouns are sensitive to this constraint, as I have illustrated in (31c).

(31c)

**pesær-i ke in ede'a ke Hassan æz u dær*
 boy-RES COMP this claim that Hassan than him in

dærsæš piši gerefteh+æst baværkærdæni nist ...
 study-his ahead achieve believable NEG-be-PRES-3sg ...

The third island constraint that I will consider here is the way coordinate structures behave like islands. Borsley (1999:207) notes that “a *wh*-dependency cannot cross the boundary of a coordinate structure unless it affects every conjunct.”

Persian example (32a) is ungrammatical because, in the coordinate structure, the question word *ki*, ‘who’, has crossed the boundary of the first conjunct but not the second. So, the first conjunct works as an island. However, in (32b) the dependency crosses both conjuncts, and therefore, the result is grammatical.

(32a)

**ki bud ke šoma ___ molaqat+kærdid væ Yasmin kolah be+sær+dašt?*
 Who was COMP you ___ visist-PAST-2pl and Yasmin hat wore-3sg?

‘Who was (the man) that you visited ___ and Yasmin was wearing a hat?’

(32b)

ki bud ke šoma ___ molaqat+kærdid væ ___ kolah be+sær+dašt?
Who was COMP you ___ visist-PAST-2pl and ___ hat wore-3sg?
'Who was (the man) that you visited ___ and ___ was wearing a hat?'

In (32b), both conjuncts contain gaps. However, in (33), we have a pair of sentences with resumptive pronouns.

(33a)

mard-i ke šoma u ra molaqat+kærdid væ be u pul dadid ...
man-RES COMP you **him** RA visited and to **him** money gave....
'The man that you visited (***him**) and gave (***him**) money to...'

(33b)

**mard-i ke šoma u ra molaqat+kærdid va be Yasmin pul dadid...*
man-RES that you **him** RA visited and to Yasmin money gave...

The example in (33a) is grammatical and shows that the Coordinate Structure Constraint is observed. The dependency crosses both conjuncts, containing resumptive pronouns. Not surprisingly, (33b) is ungrammatical because the dependency has affected only the first conjunct, and not the second.

3 The Analysis

Relative Clause constructions in Persian are unbounded dependency constructions (UDCs). (34) shows the schematic structure of Persian RCs.

(34)

NP [*ke* ___/RP]

I assume that the bottom of the unbounded dependency in Persian RCs involves a special sign that is either a trace or a RP⁸. I propose the lexical entry in (35) for RPs and the one in (36) for traces. These two lexical entries are the same except in two respects. Firstly, the value of the PHON feature in traces is an empty list. This means that RPs, as overt elements, have phonology but traces do not. The second difference between these two lexical entries is that the value of their GAPTYPE features is different. GAPTYPE is a feature that I have introduced in order to capture the distributional properties of RPs and traces. In this way, traces and RPs have different synsem values and this allows me to subject them to different constraints. GAPTYPE is a non-local feature whose value can be either *trace* or *rp*, for traces and RPs, respectively. The reason for distinguishing traces and RPs with a NONLOCAL feature is that this is not reflected within the

⁸ See Hukari and Levine (2003) for arguments in favour of traces.

value of SLASH; and hence, it is possible for a single unbounded dependency to be associated with a trace and an RP.

(35) Lexical Entry for a resumptive pronoun

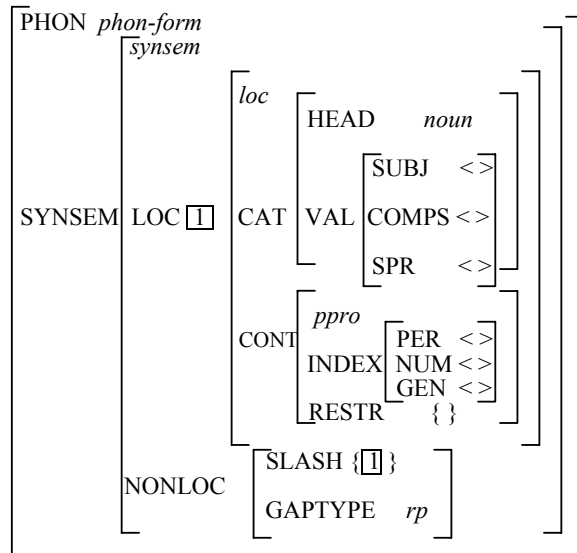

(36) Lexical Entry for a trace

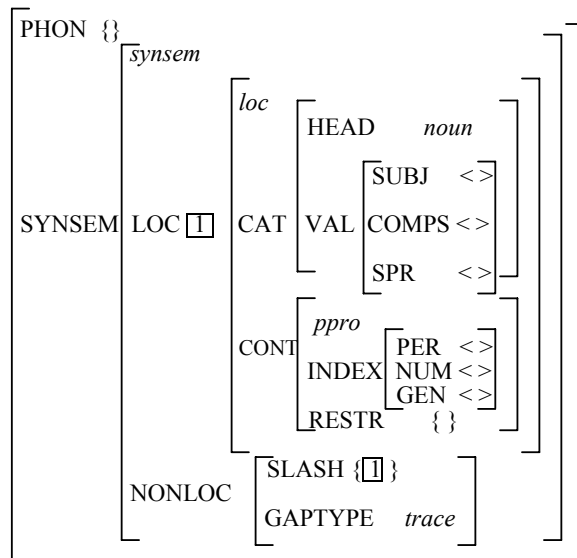

As for the pattern of distribution of RPs and traces, I will, first prevent RPs from appearing in subject position. I propose the constraint in (37) to deal with this.

$$(37) \quad [\text{SUBJ } <[1] >] \rightarrow \sim ([1] = [\text{SYNSEM}| \text{NONLOC}| \text{GAPTYPE } rp])$$

The effect of (37) is that if an element is in subject position, then the value of its GAPTYPE feature cannot be *rp*. In other words, if an element is a RP whose value of the GAPTYPE feature is *rp*, then it cannot come in subject position.

The second constraint that I will propose here is to prevent traces from appearing in the positions of object of prepositions and possessors (i.e., in positions of the complements of non-verbs). This constraint is proposed in (38).

$$(38) \quad \left[\begin{array}{l} \text{HEAD} \quad [1] \\ \text{COMPS } < \dots, [\text{GAPTYPE } trace], \dots > \end{array} \right] \rightarrow [1] = \text{verb}$$

The effect of (38) is that if there is a trace as a complement of a head, then that head has to be a verb. Therefore, as in the case of object of preposition and genitive cases (possessors), the head is not a verb, we will not have a trace therein.

In the middle of the dependency, I do not propose anything new and will follow Sag (1997). The SLASH is inherited by two constraints: Lexical Amalgamation of SLASH, and SLASH Inheritance Principle, given in (39) and (40) below.

(39) Lexical Amalgamation of SLASH

$$word \Rightarrow \left[\begin{array}{l} \text{BIND } \emptyset \\ \text{ARG-ST } < [\text{SLASH } \boxed{1}], \dots, [\text{SLASH } \boxed{2}] > \\ \text{SLASH } (\boxed{1} + \dots + \boxed{2}) - \emptyset \end{array} \right]$$

(40) SLASH Inheritance Principle (SLIP):

$$hd\text{-nexus-ph} \Rightarrow \left[\begin{array}{l} \text{SLASH } / \boxed{1} \\ \text{HD-DTR } / [\text{SLASH } \boxed{1}] \end{array} \right]$$

According to (39), all words, except SLASH binding elements like *tough*, specify empty value for the feature BIND. That is, in most cases nothing is subtracted from the disjoint union of the argument's SLASH values. Therefore, if a non-head-daughter is slashed so should the head daughter.

The constraint in (40) guarantees that the SLASH value of a phrase (of the type *head-nexus-phrase*) is- by default- the SLASH value of its head-daughter. In this way, any SLASH inheritance is mediated by the head-daughter, whose SLASH value contains that of the relevant non-head daughter.⁹

One of the virtues of the present analysis is that it uses only one nonlocal feature to handle both gaps and RPs. This makes the inheritance of the nonlocal feature easy and possible in the middle of those UDCs which involve coordination of two NPs where one contains a RP and the other a gap. Other analyses (e.g., Vaillette (2000)) which utilize more than one nonlocal feature (SLASH and RESUMP) do not seem to be able to handle the inheritance of the features in such coordinate structures, contain gap in one conjunct and RP in the other.

At the top of the dependency, I will need some way to bind the SLASH feature. In other words, I will need a way to ensure that the non-empty SLASH value stops at an appropriate point. This appropriate point, in Persian RCs, is the complementizer *ke*. I will propose the lexical entry in (41) for *ke* in RCs (i.e., *ke_{RC}*).

The lexical entry for *ke* specifies some lexical information that ensures that the index of the N' (the NP modified by the RC) is identical to the SLASH value of *ke*. This structure-sharing, which is shown by tag [1], relates the trace or the RP to the NP modified by the RC. In addition, (12) also ensures that *ke* requires a sentential complement, shown by tag [A]. Tag [A] is the only member of *ke*'s ARG-ST list that stands for a finite sentence, containing a trace or a RP. The lexical binding of SLASH is accounted for by the feature BIND, like tough adjectives. The feature BIND has a non-empty set as value for *ke*. This is shown by tag [4]. The BIND feature will ensure that the trace or the RP is not amalgamated into the SLASH value of *ke* itself.

⁹ Ginzburg and Sag (2000) use of the Generalized Head Feature Principle to do the work of (40).

(41) Lexical Entry for ke_{RC}

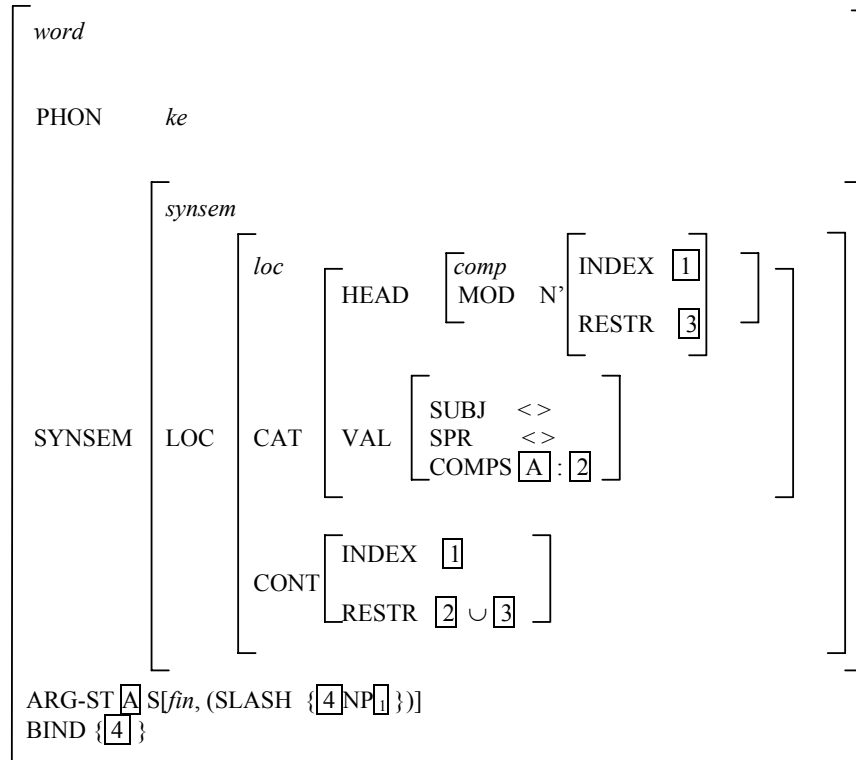

4. The Open Issues

One of the fundamental assumptions made and supported in the present paper is that there are traces in Persian RCs. An alternative analysis which someone may favour is to extend Bouma et al's (2001) traceless account to accommodate resumptive pronouns.

Also, the present analysis predicts that RPs should be okay in any unbounded dependency construction. However, they are bad in *wh*-questions. In this respect the analysis needs some refinement.

References:

- Borsley, R., 1997. *Modern Phrase Structure Grammar*. Blackwell Publishers, UK.
- Bouma, G., R. Malouf, and I. Sag, 2001. Satisfying Constraints on Extraction and Adjunction. *Natural Language and Linguistic Theory* 19:1-65.
- Chomsky, N., 1982. *Some Concepts and Consequences of the Theory of Government and Binding*. Linguistic Inquiry Monograph 6. Cambridge, Massachusetts: MIT Press.

- Dabirmoghaddam, M., 1990. On Postposition Ra in Persian. *Iranian Journal of Linguistics*. 7: 1: 2-60.
- Engdahl, E., 1985. Parasitic Gaps, Resumptive Pronouns, and Subject Extractions. *Linguistics* 23: 3-44.
- Ginzburg J. and I. Sag, 2000. *Interrogative Investigations: The Form, Meaning, and Use of English Interrogatives*. CSLI Publications, Stanford.
- Karimi, S., 1990. "Obliqueness, Specificity, and Discourse Functions: *râ* in Persian," *Linguistic Analysis*, Vol. 3&4. PP 139-191
- Karimi, S., 1999. A Note on Parasitic Gaps and Specificity. *Linguistic Inquiry* 30: 704-713.
- Levine, R. and T. Hukari, 2003. *The Unity of Unbounded Dependency Constructions*. CSLI. Stanford. California. USA.
- Levine and Sag (2003), *Some Empirical Issues in the Grammar of Extraction*, Proceedings of the HPSG03 Conference, CSLI Publications.
- McCloskey, J. 1990. Resumptive Pronouns, \bar{A} -Binding, and Levels of Representation in Irish. *Syntax and Semantics* 23: 199-248.
- Miremadi, A. 1997. *Persian Syntax: A GB-based Analysis*. SAMT Publishers, Tehran.
- Pollard C., and I. Sag, 1994. *Head-Driven Phrase Structure Grammar*. The University of Chicago Press, USA.
- Ross, J., 1967. *Constraints on Variables in Syntax*. Doctoral Dissertation. MIT, Cambridge, Massachusetts.
- Safavi, K., 1994. *Some Properties of Persian Relative Clauses*. Proceedings of the 2nd Conference on Persian Linguistics, Allameh Tabatabaie University, Tehran.
- Sag, I., 1997. English Relative Clause Constructions. *Journal of Linguistics* 33: 431-484.
- Sells, P., 1987. Binding Resumptive Pronouns. *Linguistics and Philosophy* 10: 261-298.
- Vaillette, N., 2001. Hebrew Relative Clauses in HPSG. Proceedings of the 7th International Conference on Head-Driven Phrase Structure Grammar, CSLI Publications.

Towards licensing of adverbial noun phrases in HPSG

Beata Trawinski 

University of Tübingen

Proceedings of the 11th International Conference on
Head-Driven Phrase Structure Grammar

Center for Computational Linguistics, Katholieke Universiteit Leuven

Stefan Müller (Editor)

2004

Stanford, CA: CSLI Publications

pages 294–312

Trawinski, Beata. 2004. Towards licensing of adverbial noun phrases in HPSG. In Stefan Müller (ed.), *Proceedings of the 11th International Conference on Head-Driven Phrase Structure Grammar*, Center for Computational Linguistics, Katholieke Universiteit Leuven, 294–312. Stanford, CA: CSLI Publications. DOI: 10.21248/hpsg.2004.17.



Abstract

This paper focuses on aspects of the licensing of adverbial noun phrases (AdvNPs) in the HPSG grammar framework. In the first part, empirical issues will be discussed. A number of AdvNPs will be examined with respect to various linguistic phenomena in order to find out to what extent AdvNPs share syntactic and semantic properties with non-adverbial NPs. Based on empirical generalizations, a lexical constraint for licensing both AdvNPs and non-adverbial NPs will be provided. Further on, problems of structural licensing of phrases containing AdvNPs that arise within the standard HPSG framework of Pollard and Sag (1994) will be pointed out, and a possible solution will be proposed. The objective is to provide a constraint-based treatment of NPs which describes non-redundantly both their adverbial and non-adverbial usages. The analysis proposed in this paper applies lexical and phrasal implicational constraints and does not require any radical modifications or extensions of the standard HPSG geometry of Pollard and Sag (1994).

Since adverbial NPs have particularly high frequency and a wide spectrum of uses in inflectional languages such as Polish, we will take Polish data into consideration.

1 Introduction

Apart from adjectives, adverbs and relative and adverbial clauses, many languages use bare noun phrases for the purpose of modification (cf. (1) English and (2) German examples).

- (1) a. I will visit you *next week*.
b. Do it *that way*.
- (2) a. Ich besuche dich *nächste Woche*.
I visit you next week
'I will visit you next week.'
b. Er hat *den ganzen Weg* geschlafen.
he has the whole way slept
'He slept the whole way.'

In syntactic contexts such as those in (1) and (2), NPs such as the italicized NPs above clearly act as adjuncts, although, they are not prototypical modifiers.¹ Typically, they are used in syntactic structures as subjects and objects. This syntactico-functional variation indicates two different sets of syntactic and especially semantic properties. While adverbial NPs (AdvNPs) are assumed to act as semantic functors, as all modifiers do, non-adverbial NPs are usually considered as semantic

¹I thank Adam Przepiórkowski, Frank Richter, Manfred Sailer, and the reviewers and audience of the HPSG04 Conference for their comments, and Guthrun Love for her help with English.

¹Here, we will use the terms *adjunct* and *modifier* synonymously.

arguments. To capture these two sets of features properly, one could assume two lexical entries providing appropriate features for each noun that can appear both in adverbial and non-adverbial context. This strategy, however, would lead to redundancies in the lexicon.

In this paper we will attempt to treat this subject/complement–adjunct variation within the framework of HPSG in the tradition of Pollard and Sag (1994). We will propose an analysis of adverbial and non-adverbial NPs which captures their syntactic, lexico-semantic as well as combinatorial properties. Based on empirical observations, we will formulate an underspecification-based lexical constraint modeling both non-adverbial and adverbial nouns and we will provide a principle for a proper percolation of semantic information within structures containing AdvNPs.

The objective is to ensure the licensing of AdvNPs without any lexical rules and without an extension of the standard HPSG geometry. The analysis applies lexical and phrasal implicational constraints in terms of HPSG in the tradition of Pollard and Sag (1994) and enables a non-redundant description of the syntactico-functional variation of noun phrases.

AdvNPs such as those in (1) and (2) have particularly high frequency and a wide spectrum of uses in inflectional languages such as Polish. Hence, in this paper, we will take Polish data into consideration. The analysis proposed here for Polish data can be applied to NPs in other languages as well.

2 Empirical Generalizations

According to Szober (1969) and Urbańczyk (1978), among others, genitive, dative, accusative and instrumental NPs are possible in the adverbial function in Polish. While genitive AdvNPs are used for expressing temporal relations (see (3a)), dative AdvNPs denote for instance possessors (see (3b)), and accusative AdvNPs specify measure (see (3c)) and also time (see (3d)), instrumental AdvNPs are truly poly-functional (see (3e)–(3h)). There are particularly many semantic uses associated with relational instrumentals which necessarily take genitive complements, such as *celem* (‘for the purpose of’), *drogą* (‘by way of’), *kosztem* (‘at the expense of’), *względem* (‘because of’), etc. (cf. (3i)).

- (3) a. Jan odjechał *ostatniej nocy*. (time)
 Jan left last_{gen} night_{gen}
 ‘Jan left last night.’
- b. Maria wypila *koledze* piwo. (possessor)
 Maria drank colleague_{dat} beer
 ‘Maria drank colleague’s beer.’
- c. Jan zauważył Marię *metr przed sobą*. (measure)
 Jan noticed Mary meter_{acc} in front of him.
 ‘Jan noticed Mary one meter in front of him.’

- d. Maria płakała *całą godzinę*. (time)
 Maria cried whole_{acc} hour_{acc}
 ‘Maria was crying for a whole hour.’
- e. Piotr uciekł *lasem*. (space)
 Piotr escaped forest_{instr}
 ‘Piotr escaped through the forest.’
- f. Jan czyta *wieczorem*. (time)
 Jan reads evening_{instr}
 ‘Jan reads in the evening.’
- g. Maria zabiła pająka *gazetą*. (means)
 Maria killed spider newspaper_{instr}
 ‘Maria killed the spider with a newspaper.’
- h. Piotr odszedł *wolnym krokiem*. (manner)
 Piotr went slow_{instr} step_{inst}
 ‘Piotr went slowly.’
- i. Jan wyjechał *celem odpoczynku*. (goal)
 Jan left purpose_{instr} recreation_{gen}
 ‘Jan left for the purpose of recreation.’

In order to make appropriate generalizations about the distribution of Polish NPs in adverbial contexts, we will examine a range of AdvNPs with respect to determination and quantification, modification, pluralization and referentiality. The objective is to specify a set of syntactic and semantic properties that AdvNPs share with ordinary, non-adverbial NPs, and to determine properties that AdvNPs provide in contrast to ordinary NPs. Given this, we can determine whether we can describe NPs by means of only one lexical entry for each noun and what lexical constraints will be needed to license both uses of NPs.

In this paper we will focus exclusively on AdvNPs that modify VPs, leaving AdvNPs modifying NPs for a future work.

2.1 Morphological Cases in Polish

First of all we will give a short overview of morphological cases in Polish and state which cases can mark adverbial NPs.

There are seven morphological cases in contemporary Polish: nominative, genitive, dative, accusative, instrumental, locative and vocative. As we can see in Figure 1, four of the seven cases can mark AdvNPs.²

²The abbreviation RM in the gloss of the non-adverbial instrumental stands for a reflexive marker.

	NPs		AdvNPs
	<i>Jan śpi.</i>		
<i>nominative</i>	→ Jan is_sleeping 'Jan is sleeping.'	→ none	
<i>genitive</i>	→ Maria zażądała pieniędzy. Maria demanded money 'Maria demanded the money.'	→ Jan odjechał tej nocy. Jan left this night 'Jan left that night.'	
<i>dative</i>	→ Piotr dedykował swój doktorat rodzicom. Piotr dedicated his thesis parents 'Piotr dedicated his thesis to his parents.'	→ Maria wypita Janowi piwo. Maria drank John beer 'Maria drank John's beer.'	
<i>accusative</i>	→ Jan zobaczył Marię. Jan saw Maria 'Jan saw Maria.'	→ Maria płakata całą godzinę. Maria was crying whole hour 'Maria was crying for a whole hour.'	
<i>instrumental</i>	→ Jan posłużył się nożem. Jan used RM knife 'Jan used a knife.'	→ Piotr uciekł lasem. Piotr escaped forest 'Piotr escaped through the forest.'	
<i>locative</i>	→ Jan jest teraz w szkole. Jan is now in school 'Jan is in school now.'	→ none	
<i>vocative</i>	→ <i>Mamo, poczekaj!</i> mama wait 'Wait, mama!'	→ none	

Figure 1: Overview of morphological cases in Polish in the context of their use in adverbial and non-adverbial functions

While the Polish nominative is mainly used on subjects and predicative complements, the locative appears not freely, but rather as a prepositional object, and the vocative has a special, non-sentential status, genitive, dative, accusative and instrumental cases can be assigned to both argument NPs and adverbial NPs.³

Whereas the licensing of nominative-, locative- and vocative-marked nouns does not cause any problems and is rather unspectacular due to the compatibility of their syntactico-semantic features in each syntactic context in which these nouns may occur, an adequate and particularly non-redundant modeling of genitive-, dative-, accusative-, and instrumental-marked nouns seems more challenging.

Previous configurationally motivated approaches focus particularly on the aspects of case assignment to AdvNPs. Thus Emonds (1976), Bresnan and Grimshaw (1978) and McCawley (1988) treat AdvNPs as being embedded in a PP headed by a null preposition assigning case to those NPs. Larson (1985) argues against such a position, assuming that AdvNPs are bare NPs. However, since they are not governed by a case marking element, Larson (1985) proposes the feature specification [+F] for nouns heading adverbial NPs. In the case a NP cannot be structurally case marked (because it does not appear in a position governed by a case marking element), it is assigned its case from the case assigning feature specification [+F]. In contrast, Jaworska (1986) suggests a possibility based on the assumption that AdvNPs have no case at all.⁴ However, based on Polish data, she assumes a specification of the form [CASE, INST], [CASE, GEN], and [CASE, ACC] in the lexical entry of each noun that can head an adverbial NP.⁵ This strategy, however, leads to redundancies in the lexicon.

While most of the configurational studies on AdvNPs concentrate on case assignment, the constraint-based approach of Kasper (1997) discusses mainly combinatorial aspects of modifying and non-modifying NPs. In Section 3.2 we will work out the details of this approach.

In our strictly lexicalist approach, an analysis of NPs will be offered which captures both their syntactic, lexico-semantic as well as combinatorial properties. To do this we will examine AdvNPs with respect to a number of syntactic and semantic phenomena.

2.2 Determination and Quantification

In Polish, in contrast to English or German, there is no obligatory determination and quantification. NPs can occur in a sentence in a bare form. However, they are permitted to combine with determiners and quantifiers. We will examine below the ability of AdvNPs to select a determiner and a quantifier in order to find out

³For more details on morphological cases and case assignment in Polish, see Przepiórkowski (1999) for a constraint-based approach and Tajsner (1990) for a configuration-based approach.

⁴Her considerations apply to English bare NPs in an adverbial position and are based on the observation that those NPs never show any morphological variation, nor do they have any other properties that might be related to case.

⁵She does not make a statement about the dative case.

whether they behave analogically to non-adverbial NPs in this respect.⁶

- (4) a. Jan odjechał **(tej / pewnej) nocy*.
 John left this_{gen} some_{gen} night_{gen}
 ‘John left that / some night.’
- b. Maria wypła *(temu / jakiemuś / każdemu) koledze* piwo.
 Mary drank this_{dat} some_{dat} every_{dat} colleague_{dat} beer
 ‘Mary drank this / some / every colleague’s beer.’
- c. Maria uczyła się *(tę / każdą) godzinę* w domu.
 Mary studied RM this_{acc} every_{acc} hour_{acc} at home
 ‘Mary studied for that / every hour at home.’
- d. Piotr uciekł *(tym / jakimś) lasem*.
 Peter escaped this_{instr} some_{instr} forest_{instr}
 ‘Peter escaped through this / some forest.’

As we can see in the examples above,⁷ AdvNPs can occur both as bare NPs as well as in combination with determiners and quantifiers, and in this respect they behave like non-adverbial NPs. Only genitive AdvNPs show a behavior which is somewhat atypical for Polish NPs, not only permitting but requiring a determiner or a quantifier (cf. (4a)). In fact, genitive AdvNPs in Polish do not necessarily require a determiner or a quantifier. The presence of a modifier, such as *następny* (‘next’) or *pół* (‘half’), will also ensure the grammaticality of the sentence.⁸

2.3 Adjectival and Participial Modification

In this section we will examine whether AdvNPs can be modified by adjectives and adjectival participles, as are non-adverbial NPs.

- (5) a. Jan odjechał **(ostatniej / minionej) nocy*.
 John left last_{gen} past_{gen} night_{gen}
 ‘John left last / past night.’
- b. Maria wypła *(niemieckiemu / spragnionemu) koledze* piwo.
 Mary drank German_{dat} thirsty_{dat} colleague_{dat} beer
 ‘Mary drank the German / thirsty colleague’s beer.’
- c. Maria uczyła się *(całą / minioną) godzinę* w domu.
 Mary studied RM whole_{acc} past_{acc} hour_{acc} at home
 ‘Mary studied for the whole / past hour at home.’

⁶In our approach we adopt the proposal of Pollard and Sag (1994) assuming a mutual selection in structures consisting of a determiner or a quantifier and a noun, and we assume that the syntactic head of the entire phrase of that form is a noun and not a determiner or a quantifier.

⁷The notation **(X)* as used in (4a) implies that the presence of X is necessary for the grammaticality of the sentence.

⁸This observation was also made in Szober (1969) and Jaworska (1986).

- d. Piotr uciekł (*gęstym / ciemnym*) *lasem*.
 Peter escaped dense_{instr} dark_{instr} forest_{instr}
 ‘Peter escaped through the dense / dark forest.’

The examples in (5) show that genitive, dative, accusative and instrumental AdvNPs all allow adjectival and participial modification and that they behave like typical NPs in this respect. As mentioned in the previous section, genitive AdvNPs require a determiner or quantifier and/or a modifier. This fact is confirmed again by (5a).

Jaworska (1986) claims that accusative AdvNPs, similar to genitive AdvNPs, must contain modifiers, e.g. *cały* (‘whole’). However, examples such as those in (6) show that this requirement does not hold.

- (6) a. Maria pracowała *godzinę*.
 Mary worked hour_{acc}
 ‘Mary worked for an hour.’
 b. Piotr przebywał *miesiąc* w szpitalu.
 Peter stayed month_{instr} in hospital
 ‘Peter stayed in a hospital for a month.’

2.4 Pluralization

If no formal and/or lexico-semantic restrictions are present, nouns can be pluralized in a straightforward way. Below we will test whether this holds for AdvNPs as well.

- (7) a. *Jan odjechał *ostatnich noc*.
 John left last_{gen, pl} nights_{gen, pl}
 ‘John left last / past night.’
 b. Maria wypila *kolegom piwo*.
 Mary drank colleagues_{dat, pl} beer
 ‘Mary drank the colleagues’ beer.’
 c. Maria uczyła się *całe godziny* w domu.
 Mary studied RM whole_{acc, pl} hours_{acc, pl} at home
 ‘Mary studied for entire hours at home.’
 d. Piotr uciekał *lasami*.
 Peter escaped forests_{instr, pl}
 ‘Peter escaped through forests.’

As we can see dative, accusative and instrumental AdvNPs can occur in plural form. In contrast, the occurrence of genitive plural AdvNPs seems to be either very restricted in Polish or not possible at all.⁹ The ungrammaticality of (7a) can

⁹To our knowledge, there are no detailed studies on this issue so far.

be explained by the incompatibility of the semantic contribution of the adverbial genitive NP itself (as a point in time) and the semantics of plural.

2.5 Control of Relative and Personal Pronouns

In the following section, we will investigate AdvNPs with regard to referentiality. As an indication for referentiality, we will consider here the ability of a NP to control pronouns.

In (8), each AdvNP is modified by a relative clause.¹⁰ As the indices show, both genitive, dative, accusative and instrumental AdvNPs are capable of controlling relative pronouns introducing relative clauses. This fact indicates that all AdvNPs in (8) are referential.

- (8) a. Jan odjechał *tej nocy_i*, *której_i* przybyła Maria.
 John left *this_{gen} night_{gen}* which arrived Mary
 ‘John left the night that Mary arrived.’
- b. Maria wypila piwo *koledze_i*, *którego_i* nie lubi.
 Mary drank beer colleague_{dat} whom not likes
 ‘Mary drank the beer of the colleague whom she does not like.’
- c. Maria plakala *godzine_i*, w ciagu *której_i* spalila dziesiec papierosow.
 Mary cried hour_{acc} during which smoked ten cigarettes
 ‘Mary was crying for an hour, during which she smoked ten cigarettes.’
- d. Piotr uciekl *lasem_i*, *ktory_i* dobrze znal.
 Peter escaped forest_{instr} which well knew
 ‘Peter escaped through the forest which he knew well.’

The examples below confirm this assumption. Here each AdvNP in the first clause controls a personal pronoun in the second clause. This is indicated again by indexing.

- (9) a. Jan odjechał *tej nocy_i*. Była ona_i ciemna i deszczowa.
 John left *this_{gen} night_{gen}* was it dark and rainy
 ‘John left this night. It was dark and rainy.’
- b. Maria wypila *koledze_i* piwo. Dlatego był on_i zły.
 Mary drank colleague_{dat} beer that’s_why was he angry
 ‘Mary drank the colleague’s beer. That’s why he was angry.’

¹⁰Except for the relative clause in (8c), all relative clauses in (8) are restrictive. We speculate that restrictive relative clauses modifying accusative AdvNPs are uncommon in Polish, but, in fact, there are no proper studies on this topic to our knowledge. In contrast genitive, dative and instrumental AdvNPs permit both restrictive and non-restrictive relative clauses to be modified by.

Since these facts do not affect our analysis and the treatment of relative clauses exceeds the scope of this paper, these aspects of modification will be ignored here. For previous analyses of relative clauses in the HPSG framework see e.g. Pollard and Sag (1994), Sag (1997), Holler-Feldhaus (2003) or Kiss (2004).

- c. Maria płakała *godzinę_i*. Spaliła w ciągu niej_i dziesięć papierosów.
 Mary cried hour_{acc} smoked during it ten cigarettes
 ‘Mary was crying for an hour. She smoked ten cigarettes in that time.’
- d. Piotr uciekł *lasem_i*. Znał go_i dobrze.
 Peter escaped forest_{instr} knew it well
 ‘Peter escaped through the forest. He knew it well.’

2.6 Summary of Empirical Observations

In the previous sections genitive, dative, accusative and instrumental AdvNPs have been examined with respect to determinability and quantifiability, modifiability, pluralizability and referentiality. Figure 2 summarizes the results of the applied tests.

	determination/ quantification	modification	pluralization	control
<i>genitive</i>	+	+	? / –	+
<i>dative</i>	+	+	+	+
<i>accusative</i>	+	+	+	+
<i>instrumental</i>	+	+	+	+

Figure 2: Summary of the results of tests applied to AdvNPs

Except for genitive AdvNPs, which always seem to require a determiner, a quantifier or an adjective, all other AdvNPs can occur both as bare NPs and NPs containing determiners, quantifiers and adjectives, and do not differ in this respect from non-adverbial NPs. Further on, all examined AdvNPs can appear in the plural form. Finally, every AdvNP can control pronouns. We can thus conclude that AdvNPs share their syntactic features with non-adverbial NPs and, since they can act as controllers as their non-adverbial counterparts do, they are referential objects. The crucial difference between adverbial and non-adverbial NPs seems to relate to their selectional and lexico-semantic properties.

In the next section, we will provide an HPSG account of AdvNPs that reflects these generalizations.

3 The Analysis

3.1 Lexical Licensing

According to the standard HPSG approach of Pollard and Sag (1994), adjuncts are treated as both syntactic and semantic selectors. The selection proceeds via the MOD feature appropriate for the sort *substantive* and thus for all objects of type *noun*. While the MOD feature’s value of adjuncts is of sort *synsem* (cf. Figure 3), the MOD feature of non-adjuncts is valued as *none* (cf. Figure 4).

$$\left[\begin{array}{c} \text{word} \\ \text{SYNS} \left[\text{LOC} \left[\begin{array}{c} \text{CAT} | \text{HEAD} | \text{MOD:} [\text{LOC} | \text{CONT} \boxed{1}] \\ \text{CONT} | \text{RESTR} \{ \{ \text{NUCL} | \text{ARG} \boxed{1} \} \} \end{array} \right] \right] \end{array} \right]$$

Figure 3: Description of modifiers according to Pollard and Sag (1994)

$$\left[\begin{array}{c} \text{word} \\ \text{SYNS} \left[\begin{array}{c} \text{LOC} [\text{CAT} | \text{HEAD} | \text{MOD: } \textit{none}] \\ \text{CONT } \textit{content} \end{array} \right] \end{array} \right]$$

Figure 4: Description of non-modifiers according to Pollard and Sag (1994)

As shown in the previous sections, Polish genitive, dative, accusative, and instrumental NPs can occur both as adjuncts and as non-adjuncts, thus, the grammar must license nouns with the *synsem*-valued MOD attribute as well as nouns with the *none*-valued MOD attribute. Instead of specifying two separate lexical entries for each noun, we postulate one lexical entry for each noun with underspecified information about the MOD value and partially underspecified information about the CONTENT value. Further on, we propose an implicational lexical constraint containing each lexical entry as its antecedent and a disjunctive consequence ensuring the licensing of adverbial and non-adverbial nouns (cf. Figure 5).¹¹

$$\forall \boxed{1} \forall \boxed{2} \left(\left[\begin{array}{c} \text{word} \\ \text{SYNS} \left[\text{LOC} \left[\begin{array}{c} \text{CAT} | \text{HEAD } \textit{nom} \\ \text{CONT} \left[\begin{array}{c} \text{nom-obj} \\ \text{INDEX } \boxed{1} \\ \text{RESTR} \{ \boxed{2} [\text{NUCL} [\text{INST } \boxed{1}]] \} \} \end{array} \right] \end{array} \right] \right] \right] \rightarrow \left(\left[\begin{array}{c} \text{word} \\ \text{SYNS} \left[\text{LOC} \left[\begin{array}{c} \text{CAT} | \text{HEAD} | \text{MOD: } \textit{none} \\ \text{CONT} \left[\begin{array}{c} \text{nom-obj} \\ \text{INDEX } \boxed{1} \\ \text{RESTR} \{ \boxed{2} [\text{NUCL} [\text{INST } \boxed{1}]] \} \} \right] \end{array} \right] \end{array} \right] \right] \vee \left[\begin{array}{c} \text{word} \\ \text{SYNS} \left[\text{LOC} \left[\begin{array}{c} \text{CAT} | \text{HEAD} \\ \text{MOD:} [\text{CASE } \textit{gen} \vee \textit{dat} \vee \textit{acc} \vee \textit{instr}] \\ \text{MOD:} [\text{LOC} | \text{CONT } \boxed{3} \textit{psoa}] \end{array} \right] \end{array} \right] \right] \right) \end{array} \right)$$

Figure 5: Lexical Constraint for Licensing Adverbial and Non-Adverbial Nouns (preliminary version)

¹¹For simplification we assume the RESTR set in the principle in Figure 5 to contain just one element. However, we do not intend to restrict the RESTR set of all nouns in the lexicon to be singleton sets.

The symbol \downarrow indicates that the attribute ARG is undefined. In SRL this is formalized as follows: $\neg(: \text{ARG} \approx: \text{ARG})$.

According to the above principle, MOD values of the two disjuncts in the consequence become specified. While the MOD value of the first disjunct is specified as *none* (for licensing non-adverbial nouns), the MOD value of the second disjunct is a *synsem* object (for licensing adverbial nouns).

Since both adverbial and non-adverbial NPs are able to bind pronouns, we assume both to be nominal objects containing an *index*.

Note also that the *psoa* object in the RESTR set of the non-adverbial nouns differs from *psoa* object in the RESTR set of the adverbial nouns. While the relation associated with non-adverbial nouns does not introduce any additional arguments, the relation associated with adverbial nouns introduces an argument whose value is identified with the semantics of the modified VP. This reflects the intuition that adverbial nouns in contrast to non-adverbial nouns act as semantic functors.

This analysis will presuppose a sort hierarchy for semantic relations associated with nouns of the form such as those in Figure 6.

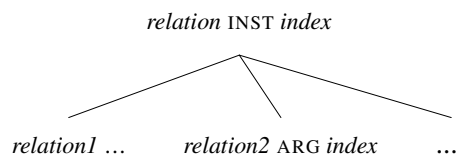

Figure 6: An exemplary sort hierarchy and feature declaration for semantic relations associated with nouns

3.2 Kasper (1997)

At this point we would like to address the approach to modification by Kasper (1997). He shows that the standard treatment of modification does not correctly handle modifiers that contain embedded modifiers and he provides a theory of modification that enables to represent the common meaning shared by different uses of the same expression as a modifier and a non-modifier.

For nouns such as *day* in English, which can act as complements (cf. (10a)) as well as modifiers (cf. (10b)) in syntactic structures,¹² he provides a lexical entry shown in Figure 7.¹³

- (10) a. Kim enjoyed *the day before yesterday*.
 b. Kim left *the day before yesterday*.

¹²The examples in (10) are taken from Kasper (1997, p. 29).

¹³Note that the architecture of the lexical entry in Figure 7 differs from that used in the standard HPSG framework of Pollard and Sag (1994). The essential discrepancies concern the MOD and the RESTR values.

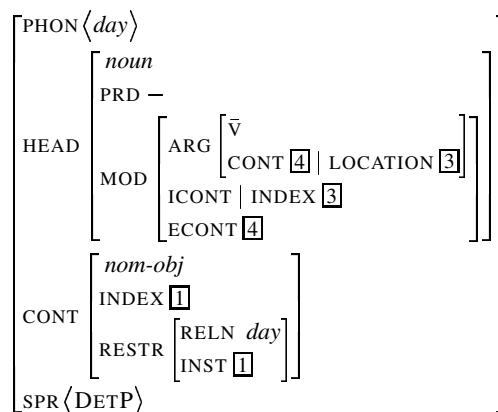

Figure 7: Description of the noun *day* according to Kasper (1997, p. 29)

Here the value of the MOD feature contains the feature ARG, which takes *synsem* as its value, the feature ICONT (internal content), which takes as its value the CONTENT value of the modifier's maximal projection, and the feature ECONT (external content), whose value is the semantic result of the functor-argument combination. The CONT attribute represents the inherent content that is specified for the lexical item.

The essential idea of this proposal is to distinguish the inherent meaning of a word or phrase from its uses in different constructions. In this theory the CONT attribute of a sign contains only its inherent semantic contribution. According to this, the CONT value of a noun used in an adverbial context is on par with the CONT value of this noun when used in a non-adverbial context. However, data such as those in (11) and (12) seem not to support this theory.

- (11) a. Maria obejrzała (cały) godzinny / czarno-biały / polski /
 Mary watched whole one-hour black and white Polish
 panoramiczny / pełnometrażowy film.
 wide-screen feature film
 'Mary watched a (whole) one-hour / black and white / Polish / wide-
 screen / feature film.'
- b. Maria płakała *(cały) godzinny / #czarno-biały / #polski /
 Mary cried whole one-hour black and white Polish
 #panoramiczny / #pełnometrażowy film.
 wide-screen feature film
 'Mary was crying the whole one-hour / #black and white / #Polish /
 #wide-screen / #feature film.'
- (12) a. Jan uszkodził asfaltową / #męczącą drogę.
 John damaged asphalt exhausting road
 'John damaged an asphalt / #exhausting road.'

- b. Jan spał całą tą #asfaltową / męczącą drogę.
 Jan slept whole this asphalt exhausting road
 ‘John was sleeping the whole #asphalt / exhausting trip.’

The (un)acceptability of the sentences above seems to relate to the (in)compatibility of lexical meanings contributed by the adjectives and the nouns. The noun *film* (‘film’) in (11) and the noun *droga* (‘way’) in (12) show in (11a) and (11b) and in (12a) and (12b) respectively different preferences with respect to adjectives they combine with. Assuming one inherent meaning for a given noun, as Kasper (1997) does, this phenomenon cannot be explained. The examples in (11) and (12) seem to indicate that adverbial nouns in (11b) and (12b) introduce a different lexico-semantic meaning to their non-adverbial counterparts in (11a) and (12a).¹⁴

Thus, unlike Kasper (1997), who does not consider these lexical ambiguities, we find it reasonable to assume different semantic relations for adverbial and non-adverbial uses of a given noun, that is not to have one fix CONTENT value for each use of a given noun.

3.3 Problems of Structural Licensing

Given the Lexical Constraint for Licensing Adverbial and non-Adverbial NPs in Figure 5 and by virtue of the HEAD-ADJUNCT SCHEMA of Pollard and Sag (1994), phrasal structures containing AdvNPs can be licensed (cf. Figure 8).

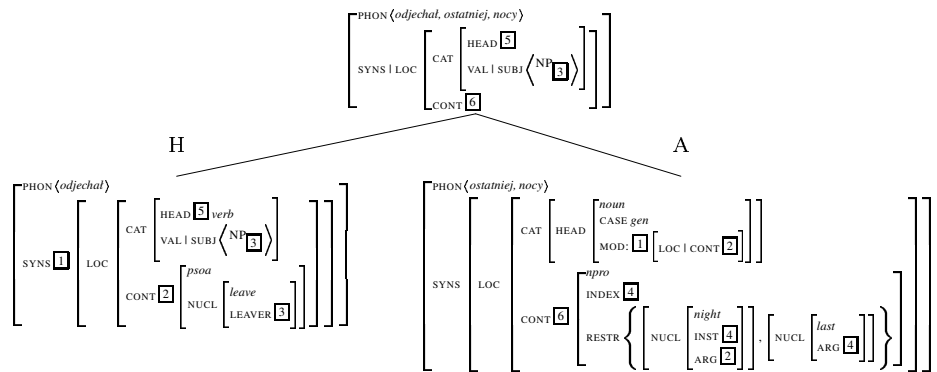

Figure 8: Description of the VP *odjechał ostatniej nocy* (‘left last night’)

The HEAD-FEATURE PRINCIPLE and the HEAD-ADJUNCT SCHEMA ensure the percolation of the head and subcategorization information along the phrase structure. However, the determination of the CONTENT value of the mother node (6) is questionable. According to the SEMANTICS PRINCIPLE of Pollard and Sag

¹⁴Note that we do not indent to indicate that a lexical meaning of a given noun is associated with some syntactic context. The distribution of nouns such as *droga* (‘way’) with the temporal meaning is not limited to the adverbial position. These nouns can also act as subjects and complements if their lexical meaning is compatible with the lexical meaning of the predicate.

(1994), the CONTENT value of the mother is token-identical to the CONTENT value of the adjunct daughter. In the case of the VP in Figure 8, this would then be the CONTENT value of the AdvNP *last night*. According to our intuition, however, the entire VP denotes an event rather than a nominal object.

In contrast, working in Davidsonian style, i.e. introducing an event variable into the semantic representation of verbs¹⁵ and assuming an architecture of the CONTENT value of verbs analogous to that of nouns,¹⁶ we can avoid these technical and conceptual problems. Thus, in our approach we assume that the CONTENT value of a verb is an object containing both an (event) index and a semantic restriction of this index (cf. Figure 9).

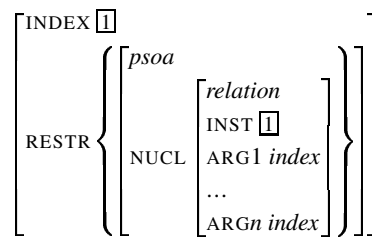

Figure 9: The *content* structure of verbs in Davidsonian style

Given this, the Lexical Constraint for Licensing Adverbial and Non-Adverbial Nouns in Figure 5 has to be reformulated. The ARG values of adverbial nouns are now token-identical to the INDEX value of the modified VP, and the value of the RESTR feature of an adverbial noun is a union of its own RESTR set and the RESTR set of the modified VP (cf. Figure 10).

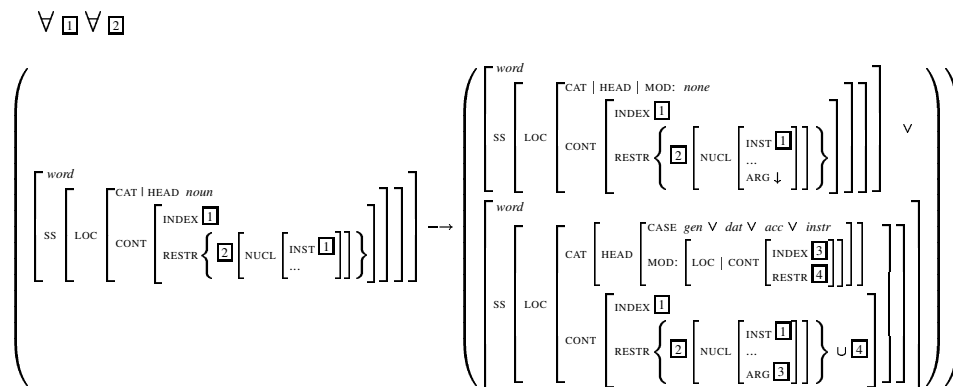

Figure 10: Lexical Constraint for Licensing Adverbial and Non-Adverbial Nouns

¹⁵Cf. Davidson (1967).

¹⁶Cf. Van Eynde (1998) or Sag and Wasow (1999) for a similar approach to the representation of the verbal semantics.

At this point we will turn to our generalizations about genitive AdvNPs. In Section 2.2 and Section 2.3 we have mentioned that genitive AdvNPs require a determiner, a quantifier and/or a modifier. This observation is formalized by means of the constraint in Figure 11, which says that if a genitive noun modifies an object then it has either to have a non-empty SPR list or its RESTR set has to contain at least two *psoa* objects, one of which is an inherent *psoa* object introduced by this noun and the second one is a *psoa* object associated with an adjective.

$$\forall \boxed{1} \forall \boxed{2} \left(\left[\begin{array}{c} \text{word} \\ \text{SYNS} \left[\begin{array}{c} \text{LOC} \left[\begin{array}{c} \text{CAT} \left[\begin{array}{c} \text{HEAD} \left[\begin{array}{c} \text{noun} \\ \text{CASE } gen \\ \text{MOD } synsem \end{array} \right] \\ \text{VAL} | \text{SPR } \boxed{1} \\ \text{CONT} | \text{RESTR } \boxed{2} \end{array} \right] \end{array} \right] \end{array} \right] \end{array} \right] \rightarrow (\boxed{1} \text{nelist} \vee \boxed{2} \{psoa, psoa, \dots\}) \end{array} \right)$$

Figure 11: Restrictions on adverbial genitives

We have also mentioned that genitive AdvNPs occur mainly (or even exclusively) in the singular form. This restriction can easily be integrated into the constraint in Figure 11. However, we are based on the assumption that this restriction is a natural consequence of independent semantic constraints.

Now we are able to reformulate the SEMANTICS PRINCIPLE so that it ensures the right percolation of semantic information along the structure.

As we have already mentioned, the INDEX value of the entire VP is expected to be token-identical to that of the head daughter. The collection of all semantic restrictions on that event is located within the adjunct daughter and is expected to be present at the mother node. This observation indicates that the RESTR value of the mother has to be token-identical to that of the adjunct daughter. Thus new SEMANTICS PRINCIPLE is as follows:

(13) SEMANTICS PRINCIPLE

In a headed phrase, the SYNSEM | LOCAL | CONTENT | INDEX value is token-identical to that of the head daughter and the SYNSEM | LOCAL | CONTENT | RESTR value is token-identical to that of the adjunct daughter, if any, and to the head daughter otherwise.

Note that the SEMANTICS PRINCIPLE in (13) corresponds to two semantic principles proposed in Sag and Wasow (1999) (cf. (14) and (15)), however it is formulated in terms of the standard HPSG framework of Pollard and Sag (1994).

(14) SEMANTIC COMPOSITIONALITY PRINCIPLE

In any well-formed phrase structure, the mother's RESTR value is the sum of the RESTR values of the daughters.

(15) SEMANTIC INHERITANCE PRINCIPLE

In any headed phrase, the mother's MODE and INDEX values are identical to those of the head daughter.

The SEMANTICS PRINCIPLE as defined in (13) is not only motivated by the licensing of phrases with AdvNPs as adjunct daughters. Besides all other structures it will make also accurate predictions about the semantics of NPs, such as *a written book*, which cannot be handled properly in the standard HPSG approach without additional stipulations (e.g. without appropriate lexical rules). It is obvious that this NP refers to a book object rather than to a writing event. However, the SEMANTICS PRINCIPLE of Pollard and Sag (1994) will provide an unexpected interpretation of this NP by identifying the CONTENT value of the entire NP with the CONTENT value of the adjunct daughter, which refers to the event of writing. In contrast, the SEMANTICS PRINCIPLE proposed here will ensure identities between the INDEX values of the mother and the head daughter and between the RESTR values of the mother and the adjunct daughters, thus licensing the expected denotation of the entire NP.

By virtue of the SEMANTICS PRINCIPLE in (13) and the the Lexical Constraint for Licensing Adverbial and Non-Adverbial Nouns in Figure 10, VPs such as *odjechał ostatniej nocy* ('left last night') in Figure 12 can be licensed with a correct syntactic and semantic representation.

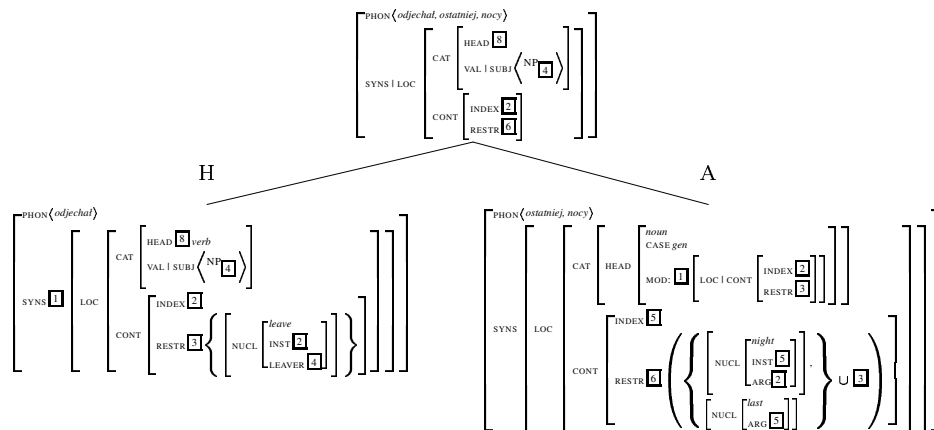

Figure 12: Description of the VP *odjechał ostatniej nocy* ('left last night')

The genitive noun *nocy* ('night') in Figure 12 is licensed by the Lexical Constraint for Licensing Adverbial and Non-Adverbial Nouns in Figure 10. By virtue of the restrictions on adverbial genitive nouns formulated in the constraint in Figure 11, the noun *nocy* ('night') must combine with the adjective *ostatniej* ('last'). The genitive NP modifies the verb *odjechał* ('left') via the feature MOD in the way proposed in Pollard and Sag (1994). Due to the uniform architecture of CONTENT value of nouns and verbs and according to the SEMANTICS PRINCIPLE in

(13), the INDEX value of the entire VP *odjechał ostatniej nocy* ('left last night') is token-identical with the INDEX value of the head daughter, that is of the verb, and the RESTR value of the VP is token-identical with the REST value of the adjunct daughter, that is of the AdvNP.

4 Summary and Outlook

In this paper, we have discussed various aspects of the licensing of adverbial NPs within the HPSG grammar framework. Based on the results of applying a range of syntactic and semantic tests to Polish AdvNPs, we have made the generalization that AdvNPs share syntactic features and the property of referentiality with non-adverbial NPs but differ from them in selectional properties.

In Section 3 we have provided a lexical principle for licensing adverbial and non-adverbial nouns, and we discussed problems with the percolation of semantic information along the complex structures involving AdvNPs in the HPSG approach of Pollard and Sag (1994). We have finally provided a principle that ensures correct semantic predictions. By the use of the underspecification-based lexical principle in Figure 10 and the SEMANTICS PRINCIPLE in (13), the modeling of both adverbial and non-adverbial NPs is enabled without the need for introducing lexical rules or extending the standard HPSG geometry and without any redundancies in the lexicon. Our approach shows again that implicational constraints as used in HPSG, also at the level of the lexicon, are an efficient mechanism for describing linguistic phenomena.

The above investigations focused on syntactic and compositional-semantic aspects of the AdvNP grammar leaving lexico-semantic factors untouched. However, an additional lexico-semantic treatment of AdvNPs will be needed to exclude over-licensing.

References

- Bresnan, Joan W. and Grimshaw, Jane. 1978. The Syntax of Free Relatives in English. *Linguistic Inquiry* 9, 331–391.
- Davidson, Donald. 1967. The Logical Form of Action Sentences. In Nicholas Rescher (ed.), *The Logic of Decision and Action*, Pittsburgh: University of Pittsburgh Press.
- Emonds, Joseph E. 1976. *A Transformational Approach to English Syntax: Root, Structure-preserving, and Local Transformations*. Academic Press.
- Holler-Feldhaus, Anke. 2003. An HPSG Analysis of the non-Integrated wh-Relative Clauses in German. In *Online Proceedings of the Tenth International Conference on HPSG, CSLI*.

- Jaworska, Ewa. 1986. *Aspects of the Syntax of Prepositions and Prepositional Phrases in English and Polish*. Ph.D.thesis, University of Oxford.
- Kasper, Robert. 1997. *Semantics of Recursive Modification*, manuscript, version of October 29, 1997.
- Kiss, Tibor. 2004. *Semantic Constraints on Relative Clause Extraposition*. To appear in the *Natural Language and Linguistic Theory*.
- Larson, Richard K. 1985. Bare NP-Adverbs. *Linguistic Inquiry* 16, 595–621.
- McCawley, James D. 1988. Adverbial NPs: Bare or Clad in See-Through Garb? *Language* 64, 583–590.
- Pollard, Carl J. and Sag, Ivan A. 1994. *Head-Driven Phrase Structure Grammar*. Chicago: The University of Chicago Press.
- Przepiórkowski, Adam. 1999. *Case Assignment and the Complement-Adjunct Dichotomy: A Non-Configurational Constraint-Based Approach*. Ph.D.thesis, University of Tübingen.
- Sag, Ivan A. 1997. English Relative Clause Constructions. *Journal of Linguistics* 33, 431–483.
- Sag, Ivan A. and Wasow, Thomas. 1999. *Syntactic Theory: A Formal Introduction*. CSLI Publications.
- Szober, Stanisław. 1969. *Gramatyka języka polskiego [The Grammar of Polish Language]*. Warszawa: PWN.
- Tajsner, Przemysław. 1990. *Case Marking in English and Polish: A Government and Binding Study*. Ph.D.thesis, Uniwersytet im. Adama Mickiewicza, Poznań, Poland.
- Urbańczyk, Stanisław (ed.). 1978. *Encyklopedia wiedzy o języku polskim [Encyclopedia of the Knowledge of Polish Language]*. Wrocław, Warszawa, Kraków, Gdańsk: Wydawnictwo Zakładu Narodowego im. Ossolińskich.
- Van Eynde, Frank. 1998. Tense, Aspect and Negation. In F. Van Eynde and P. Schmidt (eds.), *Linguistic Specifications for Typed Feature Structure Formalisms. Studies in Machine Translation and Natural Language Processing*, volume 10, pages 209–280, Luxembourg: Office for Official Publications of the European Communities.

Pied piping is a local dependency

Frank Van Eynde 

Universiteit Leuven

Proceedings of the 11th International Conference on
Head-Driven Phrase Structure Grammar

Center for Computational Linguistics, Katholieke Universiteit Leuven

Stefan Müller (Editor)

2004

Stanford, CA: CSLI Publications

pages 313–334

Van Eynde, Frank. 2004. Pied piping is a local dependency. In Stefan Müller (ed.), *Proceedings of the 11th International Conference on Head-Driven Phrase Structure Grammar, Center for Computational Linguistics, Katholieke Universiteit Leuven*, 313–334. Stanford, CA: CSLI Publications. DOI: 10.21248/hpsg.2004.18.



Abstract

As usual in the GPSG/HPSG paradigm, (Ginzburg and Sag 2000) treats pied piping as a nonlocal dependency, just like extraction. This treatment faces a number of problems, both conceptual and empirical ones. To solve them, I propose an alternative in which pied piping is treated as a local dependency. This alternative avoids the empirical problems with the nonlocal treatment, and is conceptually and formally simpler.

1 Introduction

Interrogative *wh*-clauses contain at least one *wh*-word. This word can occur in its canonical position, as in (1), but in many languages, including English, it is more common to extract it, both in root clauses (2) and in subordinate clauses (3).

- (1) You said WHAT ?
- (2) *What* did you say ...?
- (3) I do not know *what* she said ...

The extracted *wh*-constituent may be a phrase, as in:

- (4) *How long* are they going to stay ...?
- (5) I wonder *which train* we should take ...

John Ross coined the term ‘pied piping’ for this phenomenon, suggesting that the *wh*-word lures the other words of the phrase away from their canonical position, in much the same way as the pied piper in the homonymous German fairy tale lured the rats—and later the children—away from their home town Hameln. A challenge for the treatment of pied piping is to define what exactly can/must be extracted along with the *wh*-word. Compare, for instance, (5) with (6-7).

- (6) * I wonder *which* we should take ... train.
- (7) * I wonder *take which train* we should ...

Apparently, the noun must follow the *wh*-determiner, but the verb must remain in situ. Restrictions on pied piping are commonly captured in terms of constraints on the internal structure of the extracted phrase. Henk van Riemsdijk, for instance, observed that the extracted phrase is typically introduced by either a *wh*-word or a preposition, and modeled this in terms of “a feature percolation approach with the (not implausible) proviso that percolation of this kind is limited to left branches, modulo a preceding preposition.” (Van Riemsdijk 1994, 332). This accounts for the well-formedness of (4-5), since the *wh*-words are on the left branch of the AP *how long* and the NP *which train*. It also accounts for the fact that the *wh*-word may be preceded by a preposition, as in (8-9).

- (8) *To whom* did you send that letter ...?

(9) I do not know *for how long* they will stay ...

Words of other categories may not precede the *wh*-word. This accounts for the ill-formedness of (7), in which it is preceded by a verb, as well as for the ill-formedness of (10) and (11), in which it is preceded by resp. a noun and an adjective.

(10) * *Friends of whom* did they invite ...?

(11) * I do not know *proud of what* we should be ...

At the same time, Van Riemsdijk's observation does not account for the ill-formedness of (6) and the contrast in (12).

(12) I wonder *whose/*whom leaving the room* she was referring to ...

A recent attempt to provide a more complete and precise account is the HPSG-based treatment of pied piping in (Ginzburg and Sag 2000), henceforth GS-2000. It will be presented in section 2, evaluated in section 3 and replaced with an alternative in section 4.

2 The nonlocal head-driven treatment of GS-2000

As usual in the GPSG/HPSG paradigm, GS-2000 models extraction and pied piping in terms of feature sharing. The interrogative clause in *I do not know which toy they gave her* ..., for instance, is analysed as follows.

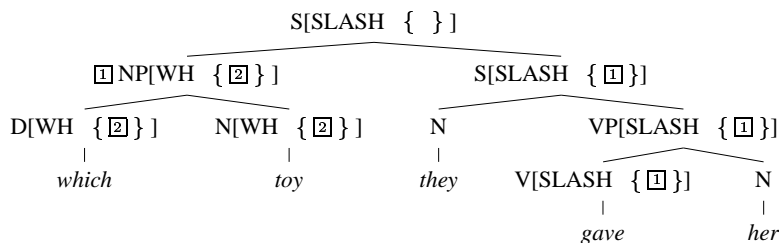

The SLASH feature models extraction (2.1) and the WH feature pied piping (2.2).

2.1 Extraction

Since the GS-2000 treatment of extraction is head-driven, I start from the head of the clause, i.e. the verb *gave*. This is one of the forms of the lexeme *give*, which is ditransitive and which, hence, selects three NP arguments.

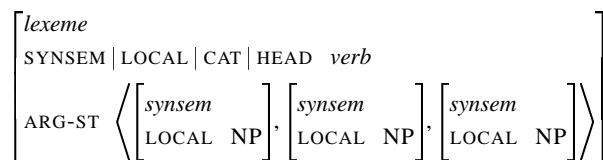

The mapping of lexemes onto words is modeled by lexical rules. They may change the phonological form of the sign, as in the case of *gave*, as well as its syntactic and semantic properties. For instance, since *gave* is finite, the first NP argument must be nominative. Besides, each of the selected arguments is assigned a more specific SYNSEM value.

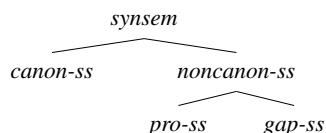

The objects of type *canon(ical)-s(yn)s(em)* are overtly realized, whereas those of type *noncan-ss* are not. The latter include the unrealized subjects of infinitival clauses (*pro-ss*) and the extracted arguments (*gap-ss*). The last NP in the ARG-ST value of *gave*, for example, is of type *gap-ss*.

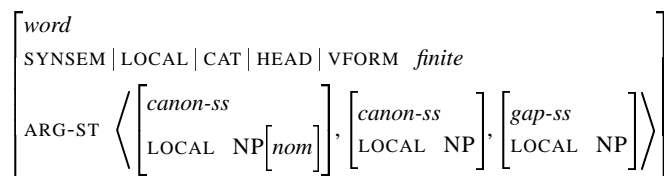

How the arguments are realized is spelled out by the ARGUMENT REALIZATION PRINCIPLE (Ginzburg and Sag 2000, 171).

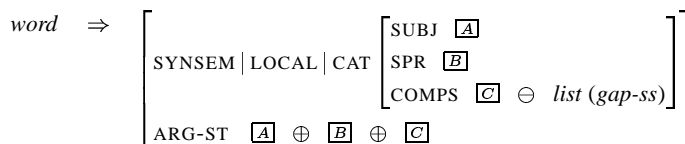

The ARG-ST list is divided in three parts. The members of the first sublist are realized as subjects, the members of the second sublist as specifiers and the members of the third sublist as complements, unless they are extracted. The extracted arguments are subsumed by a separate constraint which identifies their LOCAL value with their SLASH value (Ginzburg and Sag 2000, 170).

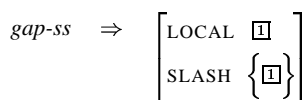

Since finite verbs have exactly one subject and no specifiers, and since the COMPS list does not contain the SYNSEM values of extracted arguments, the effect of these constraints on *gave* is the following:

$$\left[\begin{array}{c} \text{SYNSEM} \mid \text{LOCAL} \mid \text{CAT} \left[\begin{array}{l} \text{HEAD} \mid \text{VFORM } \textit{finite} \\ \text{SUBJ} \langle \boxed{1} \rangle \\ \text{SPR} \langle \rangle \\ \text{COMPS} \langle \boxed{2} \rangle \end{array} \right] \\ \text{ARG-ST} \left\langle \boxed{1} \left[\begin{array}{l} \textit{canon-ss} \\ \text{LOCAL NP}[\textit{nom}] \end{array} \right], \boxed{2} \left[\begin{array}{l} \textit{canon-ss} \\ \text{LOCAL NP} \end{array} \right], \left[\begin{array}{l} \textit{gap-ss} \\ \text{LOCAL } \boxed{3} \text{ NP} \\ \text{SLASH } \{ \boxed{3} \} \end{array} \right] \right\rangle \end{array} \right]$$

In words, the first argument is realized as the subject, the second one as a complement, and the third one is stored in the SLASH value. The latter is inherited by the head of the extracted argument, i.e. the verb. This is modeled by the SLASH AMALGAMATION CONSTRAINT (Ginzburg and Sag 2000, 169).

$$\textit{word} \Rightarrow / \left[\begin{array}{l} \text{SYNSEM} \mid \text{SLASH } \boxed{A} \cup \dots \cup \boxed{Z} \\ \text{ARG-ST} \left\langle [\text{SLASH } \boxed{A}], \dots, [\text{SLASH } \boxed{Z}] \right\rangle \end{array} \right]$$

The SLASH value of the verb is, hence, the union of the SLASH values of its arguments. Since the SLASH values of the locally realized arguments are the empty set, this implies that the SLASH value of *gave* is identical to the one of its third argument.

$$\left[\begin{array}{c} \text{SYNSEM} \left[\begin{array}{l} \text{LOCAL} \mid \text{CAT} \left[\begin{array}{l} \text{HEAD} \mid \text{VFORM } \textit{finite} \\ \text{SUBJ} \langle \boxed{1} \rangle \\ \text{COMPS} \langle \boxed{2} \rangle \end{array} \right] \\ \text{SLASH } \{ \} \cup \{ \} \cup \{ \boxed{3} \} \end{array} \right] \\ \text{ARG-ST} \left\langle \boxed{1} \left[\begin{array}{l} \textit{canon-ss} \\ \text{LOCAL NP}[\textit{nom}] \\ \text{SLASH } \{ \} \end{array} \right], \boxed{2} \left[\begin{array}{l} \textit{canon-ss} \\ \text{LOCAL NP} \\ \text{SLASH } \{ \} \end{array} \right], \left[\begin{array}{l} \textit{gap-ss} \\ \text{LOCAL } \boxed{3} \text{ NP} \\ \text{SLASH } \{ \boxed{3} \} \end{array} \right] \right\rangle \end{array} \right]$$

Given the GENERALIZED HEAD FEATURE PRINCIPLE (GHFP), which stipulates that the SYNSEM value of a phrase is—by default—identical to the one of its head daughter, the SLASH value of the verb is identified with the one of the VP and the one of the S. The latter is then combined with an extracted *wh*-phrase which has the same LOCAL value as the one of the gap. This excludes combinations in which these values do not match, as in *on which toy they gave her ...*

2.2 Pied piping

Returning now to pied piping, GS-2000 starts from the assumption that it is an unbounded dependency, just like extraction. This is motivated by the fact that extracted *wh*-words can be arbitrarily deeply embedded in the phrases which contain them, as in (13-14).

(13) *Whose cousin's friend's dog* is she going to buy ___?

(14) *How much smarter (than Paul)* do you think she really is ___?

In terms of the notation, this implies that the feature which models pied piping (WH) is a nonlocal feature, just like SLASH. Moreover, the propagation of its value is modeled by a constraint which closely resembles the one for slash amalgamation. It is called the WH-AMALGAMATION CONSTRAINT and spelled out as follows (Ginzburg and Sag 2000, 189).

$$\text{word} \Rightarrow / \left[\begin{array}{l} \text{SYNSEM} | \text{WH } \boxed{A} \cup \dots \cup \boxed{Z} \\ \text{ARG-ST } \langle [\text{WH } \boxed{A}], \dots, [\text{WH } \boxed{Z}] \rangle \end{array} \right]$$

The WH value of a word is the union of the WH values of its arguments.¹ For example, the WH value of the noun *toy* in *I wonder which toy they gave her ___* is nonempty since it has an argument with a nonempty WH value.² Given the GHFP, this value is shared between the common noun and the NP. This treatment also copes with pied piping in PPs, as in:

(15) I do not know *with which toy* they were playing ___.

The WH value of the preposition includes the one of its NP argument, because of the WHAC, and is shared with the PP, because of the GHFP.

Besides the similarities with extraction there are some differences. Notice, for instance, that pied piping is restricted by a ‘leftmost-modulo-preceding-preposition’ constraint, while extraction is not. To model this GS-2000 adds two constraints which only apply to pied piping. The first is the WH-CONSTRAINT: “Any non-initial element of a lexeme’s ARG-ST list must be [WH { }].” (p. 189). This accounts for the contrast in:

(16) I do not know *whose friends* they invited ___.

(17) * I do not know *the friends of whom* they invited ___.

¹In situ *wh*-words have the empty set as their WH value. This is logical, for since they are not extracted, they do not trigger pied piping.

²The constraint is formulated as a default, since it is overridden by the extracted *wh*-words themselves: the WH value of *which*, for instance, is nonempty, even though it does not take any arguments.

Assuming that the lexeme *friend* selects two arguments, of which the first is a determiner and the second a PP[*of*], the WHC requires the WH value of the PP to be the empty set. This, in combination with the requirement that the WH value of an extracted phrase must be nonempty, accounts for the ill-formedness of (17). By contrast, (16) is not ill-formed, since the WH value of the first argument need not be empty. The second constraint is the WH-SUBJECT PROHIBITION (p. 189).

$$word \Rightarrow \left[\text{SYNSEM} | \text{LOCAL} | \text{CAT} | \text{SUBJ} \text{ list} \left(\left[\text{WH} \{ \} \right] \right) \right]$$

Assuming that the first argument of the verbal gerund in (18) is realized as a subject, this accounts for:

(18) * I wonder *whom leaving the room* she was referring to ...

In short, pied piping is treated along the same lines as extraction, i.e. as an unbounded dependency whose constraints are modeled in a lexicalist head-driven way.

3 An evaluation of the nonlocal head-driven treatment

This section provides an evaluation of the nonlocal treatment of pied piping in GS-2000. I will demonstrate that the treatment of pied piping in NPs and APs relies on the stipulation of poorly motivated lexical rules (3.1) and on the postulation of nonbranching phrase structure rules (3.2), and that there are empirical problems with the treatment of pied piping in PPs (3.3) and in NPs with a predeterminer (3.4).

3.1 Poorly motivated lexical rules

Since the WH-CONSTRAINT applies to lexemes, rather than to words, its effect can only be measured if one also takes into account the rules which map lexemes onto words. These rules play, in fact, a crucial role in the treatment of pied piping in NPs and in APs, as will now be illustrated first for the nouns and then for the adjectives.

Typical of the common noun lexemes is that they have a determiner in the first position of their ARG-ST list (Ginzburg and Sag 2000, 190).

$$\left[\begin{array}{l} cn-lx \\ \text{SYNSEM} | \text{LOCAL} | \text{CAT} | \text{HEAD} \text{ noun} \\ \text{ARG-ST} \langle \text{DET} \rangle \oplus \boxed{A} \end{array} \right]$$

The addition of information which is specific for the various forms of the lexeme, is left to the lexical rules. One of them is the SINGULAR ATTRIBUTIVE

NOUN LEXICAL RULE. It stipulates that the first argument of a singular nonpredicative noun is realized as a specifier and that the noun's SUBJ list is empty (p. 190).

$$\begin{array}{l}
 cn-lx \Rightarrow_{LR} \left[\begin{array}{l}
 word \\
 \\
 SYNSEM | LOCAL | CAT \\
 \\
 ARG-ST \langle \boxed{1} \rangle \oplus \boxed{A}
 \end{array} \right] \left[\begin{array}{l}
 \\
 \\
 \\
 HEAD \left[\begin{array}{l}
 AGR | NUM \quad sg \\
 PRED \quad -
 \end{array} \right] \\
 SUBJ \langle \rangle \\
 SPR \langle \boxed{1} \rangle
 \end{array} \right]
 \end{array}$$

Another such rule is the SINGULAR PREDICATIVE NOUN LEXICAL RULE, which stipulates that the determiner on the ARG-ST list of a singular predicative noun is preceded by an NP which is realized as a subject (p. 409).

$$\begin{array}{l}
 cn-lx \Rightarrow_{LR} \left[\begin{array}{l}
 word \\
 \\
 SYNSEM | LOCAL | CAT \\
 \\
 ARG-ST \langle \boxed{2}, \boxed{1} \rangle \oplus \boxed{A}
 \end{array} \right] \left[\begin{array}{l}
 \\
 \\
 \\
 HEAD \left[\begin{array}{l}
 AGR | NUM \quad sg \\
 PRED \quad +
 \end{array} \right] \\
 SUBJ \langle \boxed{2} \rangle \\
 SPR \langle \boxed{1} \rangle
 \end{array} \right]
 \end{array}$$

The determiner, hence, becomes the second argument, but since the addition of the subject takes place in the mapping of the lexeme onto the word, rather than in the lexeme itself, it is not subsumed by the WHC. This accounts for the well-formedness of (19).

(19) I do not know *whose suitcase* this might be ...

Technically, these rules get the facts right, but the problem is that they simultaneously capture two distinctions which are mutually independent, i.e. the number distinction, on the one hand, and the distinction between attributive and predicative nouns, on the other hand. This implies that one needs another pair of lexical rules for the plural nouns. Such redundancy is, of course, undesirable, but—within the confines of the GS-2000 system—it is unavoidable, for if the subject were already present in the lexeme, the WHC would erroneously rule out (19), and if the subject is introduced in the mapping of lexemes onto words, then it cannot be but tied to a rule which simultaneously deals with inflection.

A similar problem holds for the adjectives. Their lexemes have an NP as the first element on their ARG-ST list which has to be realised as a subject (p. 197).

This subject is subsumed by the WHSP and since the other arguments are subsumed by the WHC, the WH value of the adjectives is invariably the empty set. This, however, is too restrictive, as shown by (20).

(20) I do not know *how happy* they really are ...

To repair this, GS-2000 adds a lexical rule which introduces a determiner in the ARG-ST list of the gradable adjectives. The rule is not spelled out and does not even have a name, but from the examples it can be inferred that it requires the extra argument to be realized as a specifier and to share its WH value with the adjective. The degree marker *how* in (20), hence, shares its nonempty WH value with the adjective *happy*. In this way, the WHC is circumvented, for since the addition of the specifier takes place in the mapping of the lexeme onto the word, its non-initial position does not matter. However, while its expediency is beyond doubt, the lexical rule suffers from the same defect as those for the common nouns: it simultaneously captures two distinctions which are mutually independent. More specifically, whether an adjective is gradable and how it is inflected are unrelated issues. This has no practical consequences for English, in which the adjectives are not inflected anyway, but for languages with adjectival inflection, such as Dutch and German, it causes a sizable amount of redundancy, since the gradable adjectives in these languages inflect in exactly the same way as the nongradable ones.

Besides the redundancy, there is the problem of the arbitrariness of these lexical rules. Notice, for instance, that the requirement of a specifier is introduced by a lexical rule in the case of the adjectives, whereas it is part of the lexemes in the case of the common nouns. Conversely, the requirement of a subject is part of the lexemes in the case of the adjectives, whereas it is introduced by a lexical rule in the case of the nouns. These differences are made to get the right results for pied piping, but are not motivated by any other facts or considerations. On the contrary, they obscure the fact that the distinction between attributive and predicative uses applies in the same way to NPs and APs.

3.2 Nonbranching phrase structure rules

Specifiers of nouns and adjectives can be left unrealised, as in *friends of my sister* and *proud of his country*. A natural way to model this is to mark their presence on the SPR list and the ARG-ST list as optional. This, however, cannot be done, since it would leave us with no account for the ungrammaticality of (21).

(21) * I do not know *friends of whom* they have invited ...

If the determiner is absent from the noun's ARG-ST list, the postnominal PP takes the first position, so that it is no longer subsumed by the WH-CONSTRAINT. To avoid this, the determiner must figure in the noun's ARG-ST list, and hence in its

SPR list, also if it is left unrealized. This in turn implies that one needs a separate phrase structure rule for the vacuous expansion from NP to N' (p. 191).³

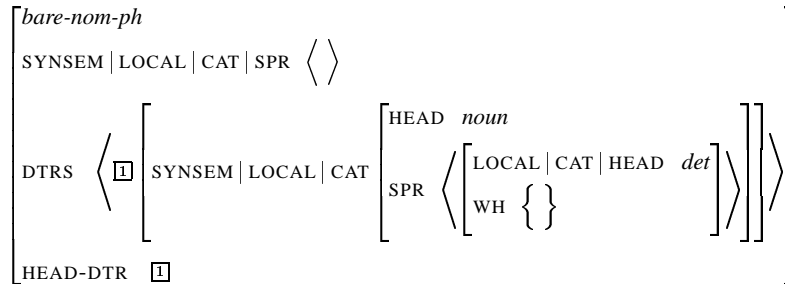

This saves the analysis, for since the absent specifier has the empty set as its WH value, and since the WH value of the PP complement is empty (because of the WHC), it follows that (21) is excluded. At the same time, though, the use of nonbranching rules introduces a level of arbitrariness in the grammar which is difficult to reconcile with the goals of a constraint-based lexicalist grammar. This is implicitly acknowledged in GS-2000, since it intentionally avoids the vacuous expansion from X' to X in the treatment of intransitive words, contrary to earlier versions of HPSG (Ginzburg and Sag 2000, 34).

3.3 Problems with PPs

If a preposition takes only one argument, this argument is, by definition, the first element on the ARG-ST list and, hence, exempt from WHC. Moreover, if the argument is realized as a complement, as in the case of the case marking prepositions, it is also exempt from the WHSP. This accounts for the grammaticality of (22).

(22) I wonder *to whom* they gave the money ...

Predicative prepositions, by contrast, have another NP on their ARG-ST list which is realized as a subject (p. 196). Since this NP is part of the ARG-ST list of the lexeme, the NP complement is subsumed by the WHC, so that the following sentences are predicted to be ill-formed.

(23) I wonder *in which countries* they have been ...

(24) I wonder *with whom* she will prefer to be ...

GS-2000 sees this as an asset, but most speakers do not regard these sentences as ill-formed. Even if they prefer the variant with a stranded preposition, they do not go as far as calling (23-24) ungrammatical.

³In the same vein, one needs a separate rule for the vacuous expansion from AP to A' (Ginzburg and Sag 2000, 198).

Another complication concerns the prepositional projections with a specifier, such as the adverbs in *just before the war* and *right under the table*. If the specifier contains a *wh*-word, it triggers pied piping, as in (25).

(25) *How long before the departure* do we have to be ready ...?

Modeling this in the GS-2000 system inevitably leads to problems, for if the specifiers of prepositions are included in the ARG-ST list of the prepositional lexemes, their NP complements are subsumed by the WHC, which implies that the following sentences are erroneously rejected as ungrammatical.

(26) I wonder *after which party* Poirot met Maigret ...

(27) I wonder *under which table* Lee is hiding his toys ...

Alternatively, if the specifiers are introduced by a lexical rule, as in the case of the gradable adjectives, the NP complements are the first arguments, so that the following sentences are erroneously accepted as well-formed.

(28) * I wonder *just after which party* Poirot met Maigret ...

(29) * I wonder *right under which table* Lee is hiding his toys ...

Moreover, whichever way the specifier is treated, since it is invariably optional, we will need a nonbranching phrase structure rule for the vacuous expansion from PP to P'.

3.4 Problems with predeterminers

In the examples discussed so far the extracted APs were either predicative or adverbial. They can also be extracted, though, when they are in a prenominal position, as in (30).

(30) I wonder *how big a risk* they are prepared to take ...

An unusual property of this combination is that the AP precedes the article. This implies that it cannot be the specifier of the noun, but at the same time it cannot be its subject either, since the NP is nonpredicative, and it cannot be its complement, since it precedes the noun. To bring it in line with the rest of the analysis, GS-2000 assumes that the AP is not a dependent of the noun, but of the article. More specifically, *how big* is treated as the first and only argument of the article (p. 200). It is realised as its specifier and, hence, exempt from both the WHC and the WHSP, so that it passes on its WH value to the article, from where it is passed on to the DetP and the NP.

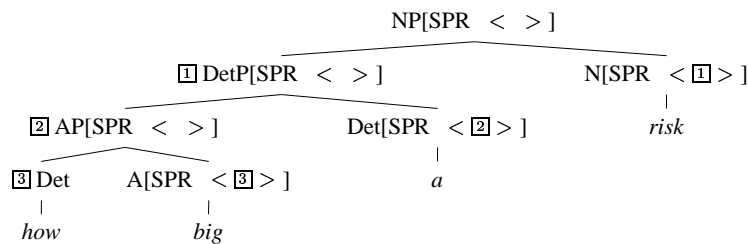

The problem with this treatment is that *how big a* does not pass any of the usual constituency tests. It never occurs on its own and if the AP is moved to a postnominal or predicative position, it does not take the article along.

- (31) This is *too big* a risk to take ...
- (32) a. This is a risk *too big* to take ...
 b. * This is risk *too big a* to take ...
- (33) a. For him, a risk is never *too big* to take ...
 b. * For him, risk is never *too big a* to take ...

Since *too* takes the same position in these APs as *how* in (30), this strongly suggests that the article in *how big a risk* combines with the noun to its right, rather than with the AP to its left. However, if this more plausible structure is adopted, the GS-2000 constraints no longer provide the result we need, since the WHAC does not foresee that a saturated NP can inherit the WH value of a prenominal AP.

3.5 Summing up

The nonlocal head-driven treatment of GS-2000 relies on poorly motivated lexical rules and nonbranching phrase structure rules to model pied piping in NPs and APs (3.1 and 3.2), it makes false predictions about pied piping in PPs (3.3), and it presupposes a highly implausible structure for NPs with predeterminers (3.4).⁴

4 A local functor-driven treatment

For the development of an alternative, I start from the assumption that pied piping is a local dependency, rather than an unbounded one. The fact that a *wh*-word can be arbitrarily deeply embedded in an extracted phrase, as in (13-14), does not provide conclusive evidence against a local treatment, since the kind of propagation which it involves is not fundamentally different from the iterative propagation which is assumed in the treatment of other phenomena which are standardly regarded as local, such as subject raising.

- (34) There seems to have been some misunderstanding.

⁴There is also a wrinkle in the formalization: the WH-CONSTRAINT is the only constraint in GS-2000 which is not cast in TFS terms.

The existential *been* requires the pronoun *there* as its subject, but this requirement is not locally satisfied. Instead, it is passed on via the auxiliary *have* and the complementizer *to* to the finite verb *seems*, and it is only at that point that the requirement is satisfied. The subject NP can, hence, be arbitrarily far removed from the predicate by which it is selected, but this is not seen as evidence for a nonlocal treatment. Instead, the SUBJ feature is part of the LOCAL|CAT values, and its content is passed on in an iterative manner from the lower to the higher predicates. In much the same way, it is possible to deal with the arbitrarily deep embeddings of *wh*-words in extracted phrases. To model this I adopt another strategy than GS-2000. Instead of introducing a device which overgenerates (the WhAC) and then adding constraints which reduce it (WhC and WhSP), I employ a device which undergenerates (4.1) and then add some ways to enhance it (4.2 and 4.3).

4.1 Functors

Several of the problems with the GS-2000 treatment can be traced back to the analysis of the specifiers, especially to the fact that they are selected by a lexical head. This not only necessitates the postulation of nonbranching phrase structure rules for NPs and APs (3.2), it also leads to unsolved problems in PPs (3.3), and it indirectly enforces the assignment of an implausible structure to nominals with predeterminers (3.4). To avoid these complications I drop the assumption that specifiers are selected by a lexical head. This does not cause any substantial loss of expressive power, since the co-occurrence restrictions which hold between a specifier and its head can be captured anyway in terms of the HEAD|SPEC feature of the specifier.

If the specifiers are no longer selected by their head, their treatment closely resembles the one of the adjuncts and the markers, as defined in (Pollard and Sag 1994). In fact, the remaining differences concern the part of speech; while the adjuncts belong to substantive parts of speech (N,V,A,P), the specifiers belong to functional parts of speech (Determiner, . . .), and the markers to a specific functional part of speech (Marker), which includes the complementizers and the coordinating conjunctions. This, however, is a weak basis for distinguishing between syntactic functions, since those functions are intended to capture cross-categorical generalizations. In the head-complement combination, for instance, both the head and its complement(s) can belong to any part of speech. To achieve the same level of cross-categorical generalization in the treatment of specifiers, adjuncts and markers, (Van Eynde 1998) introduced the head-functor type of combination. It covers all combinations in which the nonhead daughter selects and precedes its head. To spell it out I first redefine the objects of type *category*.

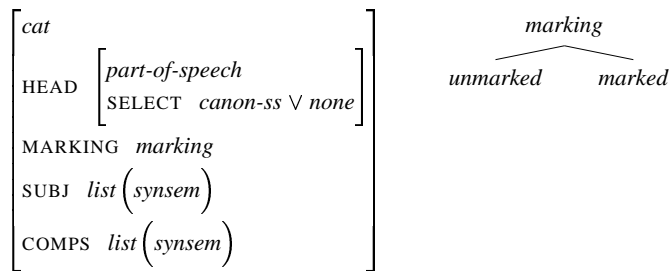

The HEAD value contains the feature SELECT which models the selection of the head sister. Its value is either an object of type *canon-synsem* or *none*.⁵ The SPR feature has been eliminated, since the specifiers are no longer selected by their head, and the MARKING feature, familiar from PS-94, has been re-introduced. The hierarchy of its values is language specific, but it minimally includes the types *marked* and *unmarked*.

Functors can now be defined as signs which select their head sister and which share their MARKING value with the mother.

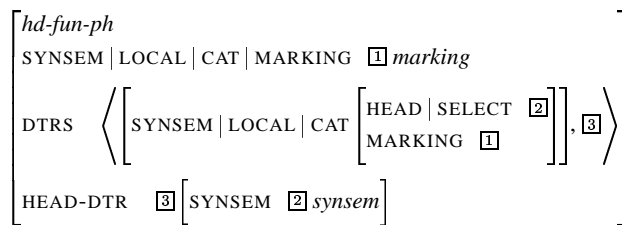

Prototypical examples of functors are the prenominal dependents. Assuming that the prenominals select an unmarked nominal as their head sister and that their MARKING value is of type *unmarked* in the case of adjectives and of type *marked* in the case of determiners, one gets the following analysis for *his many beautiful pictures*.

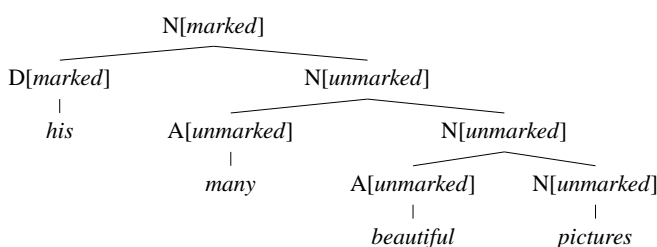

This allows the stacking of prenominal adjectives, but it excludes such ungrammatical combinations, as *beautiful his pictures* and *the his pictures*. It also excludes *the him* and *every who*, if one makes the plausible assumption that pronouns are inherently marked.

⁵The SELECT feature replaces the MOD and SPEC features of PS-94.

Superficially, the distinction between marked and unmarked nominals corresponds to the one between [SPR < >] and [SPR <XP>]. However, since the hierarchy of MARKING values can be extended with subtypes, and since these (sub)types can be enriched with further features, it provides a more flexible way to capture finer-grained distinctions, as demonstrated in Allegranza’s treatment of Italian NPs (Allegranza 1998) and in Van Eynde’s treatment of Dutch NPs (Van Eynde 2003). The latter, for instance, adds a feature for marking syntactic definiteness, thus capturing the fact that the definiteness value of an NP equals the one of its determiner.

Returning to the treatment of pied piping, I will assume that the appropriate locus for the WH feature is in the objects of type *marking*.

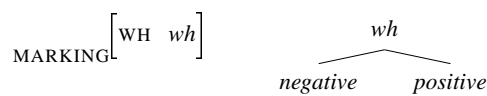

I also redefine the WH feature as boolean: *negative* corresponds to the empty set of GS-2000, *positive* to the nonempty set, and the underspecified *wh* to the set with an optional member. Employing this feature, we can now express the constraint that the nonhead daughter in a *wh*-interrogative clause (*wh-int-cl*) must be a sign with a positive WH value.



Next, I assume that all words are negatively marked for WH in the lexicon, except for the *wh*-words, i.e. the pronominal *what*, *who(m)*, *whose*, the adjectival *which* and the adverbial *why*, *where*, *when*, *how*. They are inherently marked and receive the underspecified value *wh*.

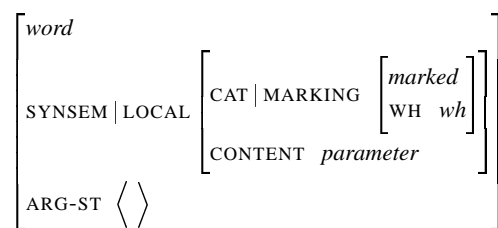

As such, they are compatible with the constraint above and, hence, admissible in the clause initial position. At the same time, they are also compatible with a negative WH value, which implies that they can be used in situ. In (35), for instance, the underspecified WH value of *what* is resolved to *positive* and the one of *whom* to *negative*.

(35) I wonder *what* she said __ to *whom*.

If the extracted constituent is a phrase rather than a single word, the constraint on *wh*-interrogatives is satisfied, if the phrase has a *wh*-word as its functor. More specifically, since a phrase shares its MARKING value with its functor daughter, and since the WH feature is part of the MARKING value, it follows that the WH values propagate from functor to mother, as in:

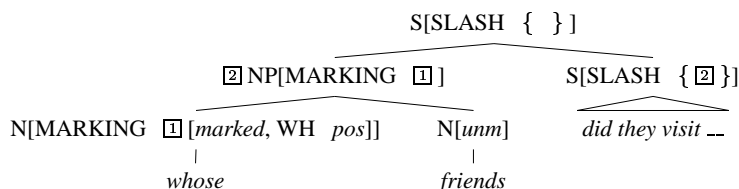

Other *wh*-words which are used as functors include the pronominal determiners in *what color* and *whose leaving the room*, the adjectival determiner in *which table* and the degree adverb in *how quick(ly)*. Functors with a negative WH value, by contrast, make the entire phrase negatively charged. This is, for instance, the case for the pronominal determiners in *this color* and *his leaving the room*, the adjectival determiner in *every bike* and the degree adverb in *too quick(ly)*.

Since functors may be phrasal, they can contain another functor, so that the MARKING value—and hence the WH value—of the extracted phrase equals the one of its functor’s functor, as in the following NP.

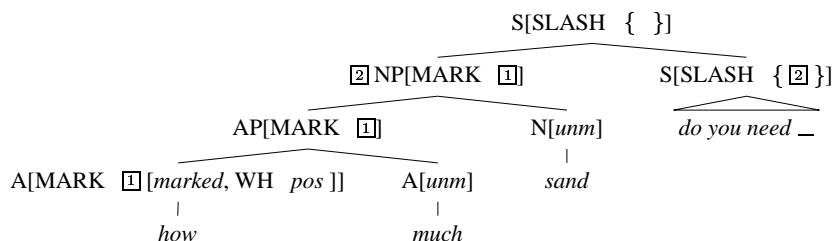

The iterative propagation of the MARKING value can also be observed in extracted APs and PPs, as in:

- (36) I wonder *how much more likely* Kim is __ to do that.
 (37) *How long before the departure* do we have to be ready __?

The fact that the *wh*-word can be arbitrarily deeply embedded in the extracted phrase is, hence, dealt with in a strictly local manner.

It may be worth stressing that the WH value is propagated directly from the functor daughter to the mother, without mediation of the lexical head. This is not only formally simpler, it also avoids overgeneration. To see this, let us suppose, for the sake of the argument, that the WH values are propagated via the head. In that case, the common nouns, the gerunds and the gradable adjectives and adverbs must all be assigned the underspecified value *wh* in the lexicon, since they may end

up in the company of a positively specified functor. As a consequence, if there is no functor, as in *friends*, *quick(ly)* and *leaving*, the WH value remains underspecified, so that they are erroneously licensed as nonhead daughters in *wh*-interrogative clauses. This complication does not arise in the functor treatment, for since all words which are not *wh*-words receive the negative WH value, they cannot pass on a positive WH value to the phrases which they head.

4.2 Pied piping in PPs

For the treatment of pied piping in PPs we need an extra device.

(38) I do not know *to whom* they sent that letter ...

(39) *For how long* are they going to stay ...?

The pronoun *whom* and the AP *how long* must share their positive WH value with the PP, but since they are not functor daughters, the propagation has to be modeled in some other way. For this purpose, I add the constraint that PPs share the WH value of their complement daughter.

$$\left[\begin{array}{l} hd-comp-ph \\ \text{SYNSEM} | \text{LOCAL} | \text{CAT} \left[\begin{array}{l} \text{HEAD } prep \\ \text{MARKING} | \text{WH } \boxed{2} \end{array} \right] \\ \text{DTRS} \left\langle \boxed{1}, \left[\text{SYNSEM} | \text{LOCAL} | \text{CAT} | \text{MARKING} | \text{WH } \boxed{2} \right] \right\rangle \\ \text{HEAD-DTR } \boxed{1} \left[\begin{array}{l} word \\ \text{PHON } list(form) \end{array} \right] \end{array} \right]$$

Also here, the WH value is passed on directly from the complement to the mother without mediation of the lexical head. This is motivated by the same consideration as in the case of the functors: if the preposition were to share the WH value of its complement, its own WH value would have to be underspecified, so that prepositions without complement would erroneously be admitted in the clause initial position of a *wh*-interrogative.

In contrast to the functors, the complements of prepositions do not share the entire MARKING value with the mother, but only the WH value. Otherwise, a PP with a marked NP complement, such as *after the party*, would be marked, and, hence, incompatible with a functor which requires an unmarked PP, as in *just after the party*.

The reason for including the PHON value of the preposition in the constraint is that it provides the means to express the intuition that there is a correlation between the phonological substance of the preposition and the felicity of pied piping. Many speakers, in fact, consider pied piping more felicitous if the lexical stress is on the first syllable of the preposition, as in *at* and *after*, than if it is on another syllable, as in *before* and *beside*.

(40) I do not remember *at/after/?before which party* she met him ...

(41) I do not know *on/under/?beside which table* he put the box ...

This intuition can be captured by a constraint on the PHON value of the preposition.

4.3 Some special cases

A combination which deserves some special attention is the one with a predeterminer, as in *how big a house*. Assuming that the prenominal AP is not a dependent of the article, but of the NP as a whole (see 3.4), this is a combination of a marked AP with a marked NP.

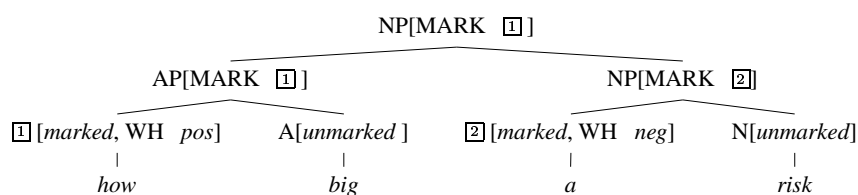

Most properties of this construction are accounted for by the functor analysis. The functor status of *how* accounts for the fact that it shares its MARKING value—and hence its WH value—with the AP and the functor status of the article accounts for the fact that it shares its MARKING value with the lower NP. The functor treatment also accounts for the ill-formedness of *a how big house*, for since the addition of the marked AP yields a marked NP, the latter is not compatible with the article, which requires an unmarked nominal.

What is not accounted for, however, is the fact that the higher NP shares its MARKING value with the AP. More specifically, it is not possible to treat the AP as a functor which selects a marked NP as its head, for since the SELECT value of the functor is shared with the one of its head daughter (*big*), the latter would be stipulated to require a marked NP as well, which is wrong. Instead, prenominal adjectives require an unmarked nominal, as illustrated by the contrast between *a big house* and **big a house*. It is only when the adjective is preceded by a marked functor, such as *how, so, too*, that it combines with a marked NP. We are, hence, dealing with a combination which cannot be modeled in terms of lexical selection. For this reason, I model it in terms of a separate type of headed phrase with the following properties.

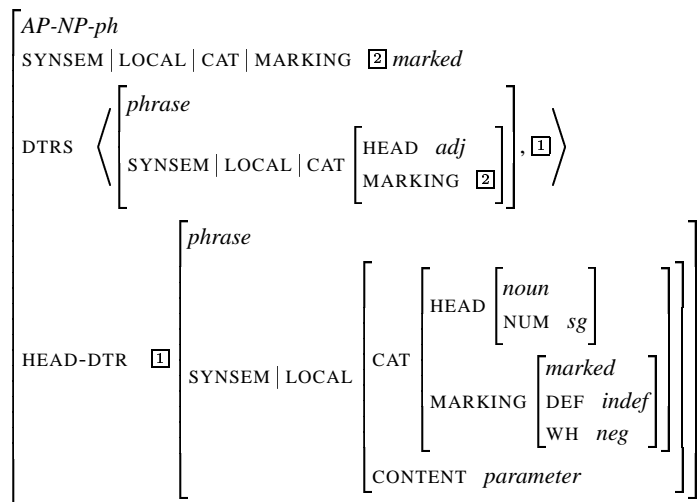

Phrases of type *AP-NP-ph* have a marked AP as their nonhead daughter, and share their MARKING value—and hence their WH value—with that AP. The head daughter is an NP and is subject to a host of restrictions. The requirement that it be singular and marked excludes combinations with plural and determinerless NPs, as in *too big houses* and *how warm water*, the indefiniteness requirement excludes combinations with a definite determiner, as in *how big this house*, the requirement for a negative WH value excludes the combination with extracted interrogatives, as in *too big which house*, and the requirement for an NP of type *parameter* excludes combinations with quantified NPs, as in *so big some house*. Finally, the requirement that the head be phrasal excludes the combination with a pronoun, as in *too big anyone*. The net result is that the NP must be introduced by the indefinite article.⁶

In this construction-based treatment of the AP-NP combination, neither daughter selects the other. Instead, all relevant restrictions are spelled out in the definition of the phrase type, including the sharing of the MARKING—and hence the WH—value. For this reason, it is not necessary to assign a special status to the predeterminers in the treatment of pied piping, since their idiosyncrasy is already captured on a more general level.

Another construction which requires some special attention is the one with the possessive clitic *'s*, as in *whose brother's bike*. To account for the possibility of pied piping the higher NP must share the WH value of the pronoun *whose*. This is partly covered by the functor treatment. More specifically, since *whose* is the functor in the lower NP *whose brother*, the latter inherits the MARKING value—and hence the WH value—of the pronoun. Similarly, since *whose brother's* is the functor in the higher NP *whose brother's bike*, the latter inherits the MARKING value—and hence

⁶In this construction the indefinite article is not used as a quantifier. In fact, most uses of the indefinite article are not quantificational, see Discourse Representation Theory.

the WH value—of the possessive phrase. What the functor treatment does not account for, though, is for the combination of the possessive clitic with the lower NP. Treating the lower NP as the functor in *whose brother's* would be implausible, since it would imply that its head (*brother*) lexically selects the possessive clitic. Further evidence against this treatment is provided by such combinations as *a man's pride* and *people's habits*. The lower NPs in these combinations are indefinite or unmarked, but the higher NPs are inherently marked and definite, just like *his pride* and *my habits*. It is clear then that the lower NP had better not be treated as a functor. As an alternative, I adopt a construction-based treatment for the combination of the possessive clitic with a preceding NP.

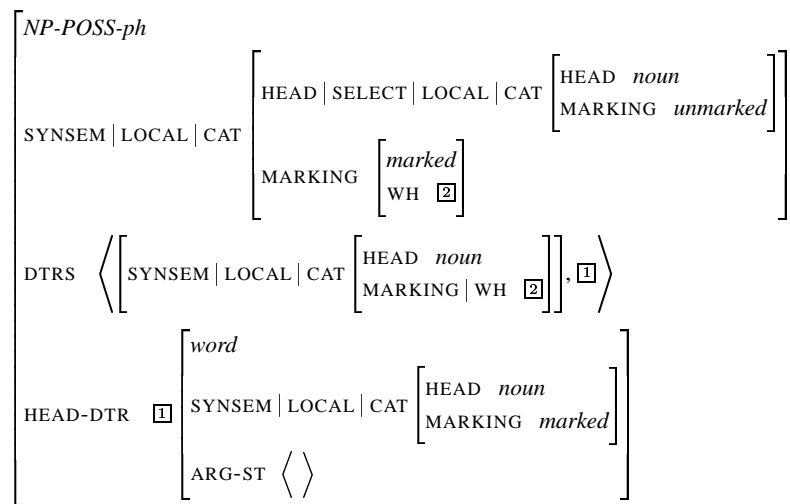

The clitic is the head daughter. It is a reduced possessive pronoun, comparable to the reduced personal pronoun in *let's dance*. Just like the other pronouns, it is inherently marked and it does not take any arguments. The nonhead daughter is an NP which shares its WH value with the mother. The latter, in its turn, is a functor which selects an unmarked nominal as its head. Given the GHFP, this SELECT value is shared with the clitic. The details of the propagation can be read off the following structure.

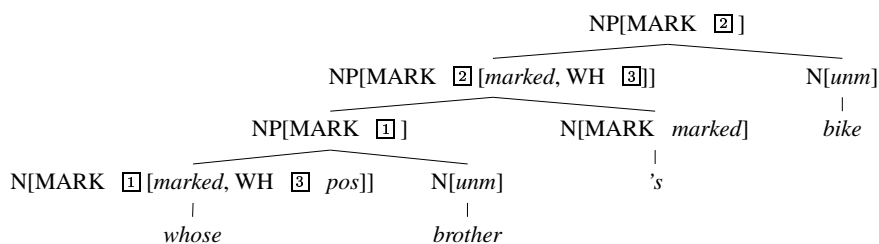

The lowest NP shares its MARKING value with the pronoun *whose*, the highest NP shares it with the possessive phrase, and the sharing of the WH value between the lowest NP and the possessive phrase is modeled by *NP-POSS-ph*.

It may be worth adding that the construction-based treatment of the AP-NP and NP-POSS combinations is not only motivated by the fact that they are not amenable to a purely lexicalist treatment, but also by the fact that they display unusual properties. In this respect, they are comparable to the inversion construction, which—at least in English—is so idiosyncratic that it is commonly assumed to require treatment in terms of a separate type of phrases, see PS-94.

4.4 Summing up

This concludes the survey of the ways in which positive WH values can be propagated. Together, they suffice to allow all the well-formed cases of pied piping in English *wh*-interrogatives.⁷ At the same time, they are sufficiently restrictive to disallow the ill-formed ones. To show this, let us take another look at the ungrammatical sentences which were used in the previous sections.

- (42) a. * I do not know (*the*) *friends of whom* they have invited ___
 b. * I do not know *proud of what* we should be ___
 c. * I wonder *take which train* we should ___
 d. * *Stay how long* are they going to ___?
 e. * I wonder *whom leaving the room* she was referring to ___
- (43) a. * I wonder *just after which party* Poirot met Maigret ___
 b. * I wonder *right under which table* Lee is hiding his toys ___
- (44) * I wonder *which* we should take __ train.

The ill-formedness of the examples in (42) is due to the fact that nouns, adjectives and verbs are negatively specified for WH. This implies that their phrasal projections are also negatively specified, unless they are preceded by a nonhead daughter with a positive WH value. This can be a functor, a predeterminer or a possessive phrase, but not a complement, as in (a-c), an adjunct, as in (d), or a subject, as in (e). The examples in (43) are ill-formed, since the PPs contain a functor with a negative WH value, and the ungrammaticality of (44) follows from the fact that the *synsem* objects which are selected by functors must be of type *canon-ss*, which excludes the type *gap-ss*.

5 Conclusion

To model the pied piping in interrogative clauses GS-2000 proposes a nonlocal head-driven treatment. This treatment has a number of drawbacks: It relies on poorly motivated lexical rules and nonbranching phrase structure rules, it makes

⁷Other languages may be more or less restrictive than English. German, for instance, allows pied piping in infinitival VPs, as in *Ich weiss nicht, wen zu überzeugen er sich vergeblich bemühte* — This can be modeled along the same lines as the pied piping in English PPs, i.e. by allowing the VP[*zu-inf*] to share the WH value of its first complement daughter.

false predictions about pied piping in PPs, and it presupposes an implausible structure for NPs with predeterminers. To solve these problems I have proposed an alternative in which pied piping is treated as a local dependency. Technically, the WH feature is integrated in the CATEGORY objects, and the propagation of its values is modeled by constraints which are independently needed for the treatment of other phenomena, such as the sharing of the MARKING value in phrases of type head-functor. The resulting treatment has no separate constraints for the propagation of WH values (such as the WhAC, the WhC and WhSP), it has no nonbranching phrase structure rules, and it does not rely on lexical rules.⁸

References

- Allegranza, V. (1998). Determiners as functors: NP structure in Italian, in S. Balari and L. Dini (eds), *Romance in HPSG*, CSLI Publications, Stanford, pp. 55–107.
- Ginzburg, J. and Sag, I. (2000). *Interrogative Investigations*, CSLI, Stanford.
- Pollard, C. and Sag, I. (1994). *Head-driven Phrase Structure Grammar*, CSLI Publications and University of Chicago Press, Stanford/Chicago.
- Van Eynde, F. (1998). The immediate dominance schemata of HPSG, in P.-A. Coppen, H. van Halteren and L. Teunissen (eds), *Computational Linguistics in the Netherlands 1997*, Rodopi, Amsterdam/Atlanta, pp. 119–133.
- Van Eynde, F. (2003). Prenominals in Dutch, in J.-B. Kim and S. Wechsler (eds), *On-line Proceedings of HPSG 2002*, CSLI Publications, Stanford University, pp. 333–356.
- Van Riemsdijk, H. (1994). Another note on clausal pied-piping, in G. Cinque, J. Koster, J.-Y. Pollock, L. Rizzi and R. Zanuttini (eds), *Paths towards universal grammar*, Georgetown University Press, Washington, D.C., pp. 331–342.

⁸Just like the GS-2000 treatment, the alternative local treatment also deals with pied piping in exclamative clauses, but not with pied piping in relative clauses.

A comprehensive theory of coordination of unlikes

Shûichi Yatabe 

University of Tokyo

Proceedings of the 11th International Conference on
Head-Driven Phrase Structure Grammar

Center for Computational Linguistics, Katholieke Universiteit Leuven

Stefan Müller (Editor)

2004

Stanford, CA: CSLI Publications

pages 335–355

Yatabe, Shûichi. 2004. A comprehensive theory of coordination of unlikes. In Stefan Müller (ed.), *Proceedings of the 11th International Conference on Head-Driven Phrase Structure Grammar*, Center for Computational Linguistics, Katholieke Universiteit Leuven, 335–355. Stanford, CA: CSLI Publications. DOI: 10.21248/hpsg.2004.19.



Abstract

The principal aim of this paper is to present a comprehensive theory of coordination of unlikes, i.e., a theory that is capable of dealing with every phenomenon resulting from coordination of unlikes. The proposed theory accounts not just for standard cases of coordination of unlike arguments and coordination of unlike functors but also for cases involving single-conjunct agreement and what will be called each-conjunct agreement. In the course of the argumentation, it is also shown that, even in a language like English, predicate-argument agreement needs to be described in terms of a relational constraint that is not simply an identity requirement.

1 Introduction

The principal aim of this paper is to present a comprehensive theory of coordination of unlikes, i.e., a theory that is capable of dealing with every phenomenon resulting from coordination of unlikes.

Coordination of unlikes is a type of coordination in which the conjuncts do not belong to the same syntactic category, and is exemplified by the following sentences.

- (1) Stupid or a liar is what Pat is.
(from Munn (2000))
- (2) Sie hat Karl gefunden und geholfen.
she has Karl found and helped
'She found and helped Karl.'
(from Pullum and Zwicky (1986))

(1) involves coordination of an AP (*stupid*) and an NP (*a liar*). This example makes it clear (pace Maxwell III and Manning (1996), Crysmann (2003), and Beavers and Sag (2004)) that there are cases of coordination of unlikes that cannot be explained away as cases of conjunction reduction. (2) involves coordination of a verb subcategorizing for an accusative object (*gefunden*) and a verb subcategorizing for a dative object (*geholfen*).

Most previous theories of coordination of unlikes are more or less successful in dealing with examples like (1) and (2), but none of them can be said to be capable of dealing with every phenomenon resulting from coordination of unlikes, as will be shown below.

I will start with reviewing some of the previous theories, with a view to familiarizing ourselves with the kinds of pitfalls that a comprehensive theory of coordination of unlikes needs to circumvent, and then will go on to present an alternative theory.

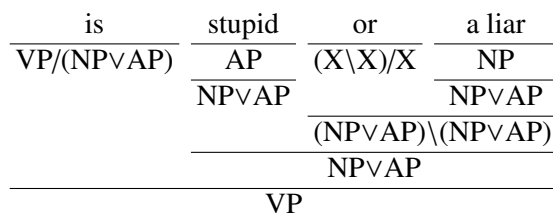

Figure 1: Coordination of unlike arguments in Bayer’s theory

2 Problems with previous theories

2.1 Bayer (1996)

I will first review Bayer’s theory of coordination of unlikes (Bayer (1996)) here because his is arguably one of the most well-developed of the theories of coordination of unlikes that have been proposed in the literature, and it is also the only theory of coordination of unlikes that is equipped with an explicit account of right-node raising.

Bayer’s theory is couched in the terms of Lambek Categorical Grammar; the way it generates a VP of the form *is stupid or a liar* is illustrated in Figure 1. In his theory, a string belonging to the syntactic category AP also belongs to the syntactic category $NP \vee AP$ (because if something is an AP, we know that it is either an NP or an AP, intuitively speaking); likewise, a string belonging to the syntactic category NP also belongs to the syntactic category $NP \vee AP$ (because if something is an NP, we know that it is either an NP or an AP). Given this setting, what appears to be coordination of unlikes turns out not to be coordination of unlikes after all; in the example depicted in Figure 1, what appears to be coordination of an AP and an NP is in fact coordination of two strings belonging to the same category, namely $NP \vee AP$.

Bayer demonstrates that his theory is capable of dealing with coordination of unlike arguments (exemplified by (1) above) and coordination of unlike functors (exemplified by (2) above) in a strikingly simple, unified manner. However, the theory has the following two shortcomings.

First, his theory cannot handle cases in which two or more homophonous expressions with different meanings are fused together and right-node-raised, because his theory is specifically designed so as not to allow a single expression to have more than one meaning. For instance, despite the author’s claim to the contrary, his theory has difficulty in dealing with examples like (3), in which the singular common noun *Dozenten* and the plural common noun *Dozenten*, which happen to be homophonous, are fused together and right-node-raised.

- (3) der Antrag des oder der Dozenten
 (=der Antrag des Dozenten oder der Dozenten)

‘the petition of the docent or the docents’
(from Eisenberg (1973))

Bayer notes that this example poses no problem for his theory if it is assumed (following Zaenen and Karttunen (1984) and Ingria (1990)) that morphological number is not semantically potent at the common noun level and comes to have meaning only at the NP level, and he presents some very interesting (if not conclusive) evidence for this assumption. However, this proposal is not a general enough solution for this problem, as shown by the existence of an example like (4).

- (4) Peter beschreibt den, und Martin beschreibt das Quark.
(=Peter beschreibt den Quark und Martin beschreibt das Quark.)
‘Peter describes the fresh cheese and Martin describes the quark.’
(from Hartmann (2000))

The word *Quark* has two senses: with the masculine article, it refers to fresh cheese, while with the neuter article, it refers to an elementary particle. It is not possible to handle an example like this in terms of morphological number that remains semantically inert at the common noun level.

Another problem with Bayer’s theory is that, as the author notes himself, it is not capable of dealing with single-conjunct agreement, an agreement pattern in which two or more expressions with distinct agreement-related properties are conjoined and one of them, instead of the coordinate structure as a whole, agrees with something outside that coordinate structure. This agreement pattern is exemplified by the sentences in (5), taken from Morgan (1984).

- (5) a. There was/*were a man and two women in the room.
b. There were/*was two women and a man in the room.

In each of these examples, the verb agrees with the first conjunct alone, and not with the coordinate structure as a whole. Bayer’s theory is not compatible with the existence of single-conjunct agreement because the linear order between conjuncts cannot have any significance in his theory; a coordinate structure of the form [NP_{PL} and NP_{SING}], for instance, is given exactly the same status as a coordinate structure of the form [NP_{SING} and NP_{PL}], making it impossible to capture the fact that the former, but not the latter, can appear immediately after the string *There were*.

It has been claimed in Peterson (1986) and Peterson (2004) that single-conjunct agreement is an extragrammatical phenomenon.¹ Peterson’s view can be summarized as follows. There is considerable intra- and inter-speaker variation in usage of single-conjunct agreement. This is because single-conjunct agreement is not something that is dictated by the grammar. Single-conjunct agreement is a ‘strategy’ that speakers sometimes resort to in order to determine verbal number when

¹See Sobin (1997) for an analogous view.

it is not determined by the grammar. A ‘strategy’ is a working principle by which speakers extemporaneously ‘patch up’ gaps left by the grammar.

Peterson’s view of single-conjunct agreement is problematic for the following two reasons. First, in some languages, single-conjunct agreement is a robust, established phenomenon without intra- or inter-speaker variation, as we will see shortly. Second, there is nothing special about speakers feeling unsure about certain aspects of their own language and showing variability. For instance, speakers can be unsure about the meaning of a word that is used only infrequently. Speakers can also be unsure about the pronunciation of a word that is used only infrequently. Likewise, speakers can be unsure about the syntactic rule governing an agreement pattern that is used only infrequently. There does not seem to be any particular reason to believe that this third situation involves anything special that is not involved in the first two situations.

Dalrymple and Kaplan (2000), Daniels (2002), Levy and Pollard (2002), and Sag (2003) represent interesting attempts to improve on Bayer’s theory, but they do not offer new insight regarding the two problems discussed in this subsection, namely the problem of right-node raising of semantically distinct expressions and the problem of single-conjunct agreement.

2.2 Moosally (1999)

The phenomenon of single-conjunct agreement has been given an HPSG-based analysis by Moosally (1999). Discussing the agreement patterns seen in Ndebele, Moosally divides coordinate NPs in the language into the following three types:

- regular-agreement NPs, whose GEND value is identical to the GEND value of each of its conjuncts,
- partial-agreement NPs, whose GEND value is identical to the GEND value of the first (or the last) conjunct, and
- resolution-agreement NPs, whose GEND value is determined by a certain feature-resolution mechanism.

Partial-agreement NPs are the ones that exhibit single-conjunct agreement when used as the subject or the object of a verb.

This seems to be an adequate account of the Ndebele facts that Moosally discusses. However, this analysis cannot be applied to cases involving what Munn (2000) calls mixed agreement, a situation in which one coordinate structure shows a mixture of two or more agreement patterns. (6) and (7), taken from Sadler (2003), are Welsh examples that involve mixed agreement. In (6), for example, the subject noun phrase (*i ac Emyr*), which consists of two conjuncts, agrees with the preceding singular verb (*roeddwn*) and the following plural predicate nominal (*ysgrifenywr*) at the same time; the subject NP is taking part in single-conjunct agreement and another, more regular type of agreement simultaneously. Likewise, in (7), the subject noun phrase (*i a Gwenllian*), which consists of two conjuncts, agrees with the preceding singular verb (*dw*) and the following plural anaphoric pronominal

form (*ein*). Again, the subject NP is taking part in two different kinds of agreement relations simultaneously. (Munn (2000) discusses Brazilian Portuguese examples of an analogous nature.)

(6) Roeddwn i ac Emyr yn ysgrifenyddion rhagorol.
was-1S I and Emyr PT writers excellent
'Emyr and I were excellent writers.'

(7) Dw i a Gwenllian heb gael ein talu.
am.1S I and Gwenllian without get 1PL pay
'Gwenllian and I have not been paid.'

Sadler (2003) summarizes the relevant Welsh facts as follows.

- Head-argument agreement suggests that the coordinate structure bears the agreement features associated with an initial, pronominal conjunct.
- But evidence from anaphora and predicate agreement suggests that the coordinate structure bears semantically resolved person and number agreement features.

A situation like this cannot be handled properly in Moosally's theory, let alone Bayer's theory.

2.3 Sadler (2003)

Examples like (6) and (7) above do not pose a problem for Sadler's LFG-based theory of single-conjunct agreement (Sadler (2003)). In Sadler's theory, a coordinate NP has two agreement-related features, AGR and INDEX. The AGR value of a coordinate NP is identical to the INDEX value of the initial conjunct and is utilized for single-conjunct agreement, whereas the INDEX value of a coordinate NP results from some kind of feature resolution and is utilized for agreement patterns in which the entire coordinate structure appears to be in an agreement relation with something else.

Although Sadler's account captures the above Welsh facts in a concise manner, it has the following shortcomings.

First, since Sadler's theory makes use of a feature AGR, whose sole function is to enable single-conjunct agreement, it predicts that single-conjunct agreement must be a fairly rare phenomenon. This prediction might be correct for SVO and SOV clauses, but it is not correct for VSO clauses. Single-conjunct agreement is a prevalent agreement pattern in VSO clauses, as shown in Doron (2000).

Second, more importantly, Sadler's theory cannot deal with an agreement pattern which I will call *each-conjunct agreement*. One example of each-conjunct agreement is the agreement pattern we see in English sentences in which a verb agrees with a subject NP of the form *X or Y*. As has been noted by Pullum and Zwicky (1986) and others, when an English verb has to agree with a subject NP consisting of disjunctively conjoined NPs, the verb has to agree with each conjunct. Consider the following examples.

(8) (from Sobin (1997))

- a. You or I ??are/*am/*is wrong.
- b. You or I must be wrong.

There is no way to make (8a) perfect, because there is no form of the verb *be* that agrees with *you* and *I* at the same time. On the other hand, (8b) is perfect because the auxiliary verb *must* agrees both with *you* and with *I*. Sadler's theory does not provide a means to capture this set of facts; although the f-structure corresponding to a coordinate NP is equipped with the AGR feature, which shows the agreement-related property of a single, designated conjunct (the initial conjunct in the case of Welsh NPs), it is not equipped with a feature that shows the agreement-related properties of conjuncts other than that single, designated conjunct.

3 The grammar of constituent coordination

In this section, I will present a novel theory of coordination of unlikes and show that it is as successful as Bayer's theory in dealing with examples like (1) and (2). The way the theory circumvents the two problems that beset Bayer's theory will be explained in later sections.

I will describe the intuition behind the theory before presenting the theory itself. I take what has been called Wasow's generalization as the point of departure.

(9) Wasow's generalization:

An element in construction with a coordinate constituent must be syntactically construable with each conjunct. Thus, a structure of the form

D [A, B, and C]

is grammatical only if structures of the form DA, DB, and DC are each grammatical.

While it is obviously not impeccably correct in the form given here, Wasow's generalization is a succinct, insightful description of what we regularly see in cases involving coordination of unlikes. What I called each-conjunct agreement above is a prime example of what this generalization successfully captures. Now, one way to implement Wasow's generalization in one's grammatical theory would be to assume that an element in construction with a coordinate constituent has access to the syntactic property of each conjunct, not just the syntactic property of the coordinate constituent as a whole. Such a move might look like overkill, but it would provide us with a very simple and unified way to capture both single-conjunct agreement and each-conjunct agreement, as well as more standard instances of coordination of unlikes such as (1) and (2).

(10) is the gist of the proposed theory, which is based on the intuition just described.

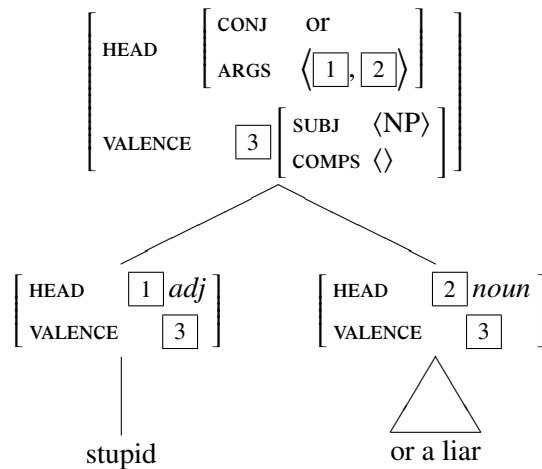

Figure 2: The internal structure of the phrase *stupid or a liar*

(10) Suppose that a coordinate structure M is made up of n conjunct daughters, $d_1 \cdots d_n$ from left to right. Then the following must hold.

(i) The HEAD value of M is

$$\left[\begin{array}{l} \text{CONJ} \quad [0] \\ \text{ARGS} \quad \langle [1], \dots, [n] \rangle \end{array} \right],$$

where $[1] \cdots [n]$ are the HEAD values of $d_1 \cdots d_n$ respectively, and $[0]$ is the SYNSEM|CONT|KEY|RELN value of M .

(ii) The VALENCE value of M is identical to the VALENCE value of each of the conjunct daughters, $d_1 \cdots d_n$.

I assume that MOD is a VALENCE feature, not a HEAD feature (Yatabe (2003); Sag et al. (2003)). On this account, the internal structure of the phrase *stupid or a liar* in example (1) is claimed to be as shown in Figure 2 (assuming that a predicative nominal has a subject slot that is not overtly filled).

Given this analysis of constituent coordination, it is trivially easy to account for the existence of sentences like (1) above and (11) below, which involve coordination of unlike arguments; all that needs to be done is to set up lexical entries such as the one shown in Figure 3, which take into account the fact that subjects and complements they take may turn out to involve coordination.

(11) We emphasized Mr. Colson's many qualifications and that he had worked at the White House. (from Bayer (1996))

Notice that the only aspect in which Figure 3 deviates from what is standardly assumed in HPSG is the use of the functor symbol c within the specification of the subcategorization frame. The meaning of the functor symbol c is defined in (12)

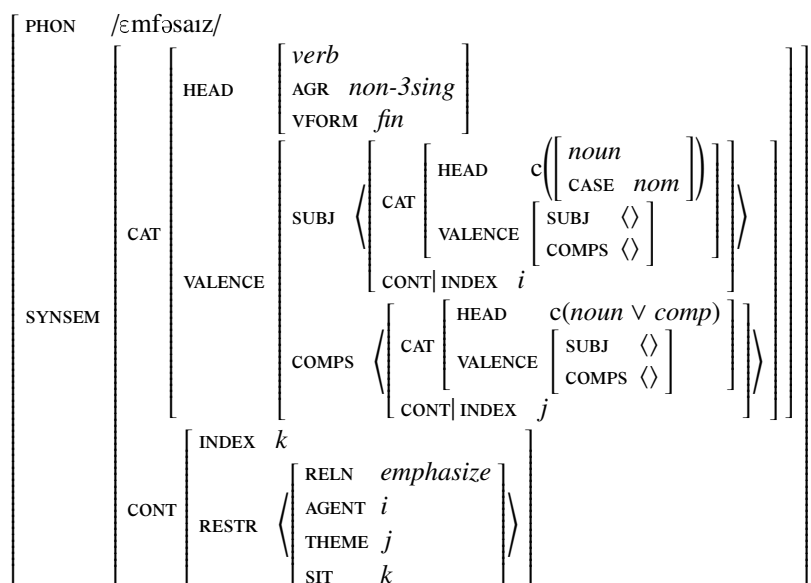

Figure 3: Part of the lexical entry for *emphasize*

below. Roughly speaking, $c(\alpha)$ is an appropriate description of an object X if and only if either α is an appropriate description of X or X is a possibly nested ‘coordinate structure’ such that α is an appropriate description of each of its ‘conjuncts’. The lexical entry in Figure 3 is in effect saying (i) that the subject of this verb must be either a nominative NP or a possibly nested coordinate structure whose conjuncts are all nominative NPs² and (ii) that the complement of this verb must be an NP, a CP, or a possibly nested coordinate structure each of whose conjuncts is either an NP or a CP.

$$\begin{aligned}
 (12) \quad \boxed{1} : c(\alpha) \equiv & \\
 & \boxed{1} : \alpha \\
 \vee & \left(\boxed{1} : \left[\text{ARGS } \langle \boxed{a_1}, \dots, \boxed{a_n} \rangle \right] \right. \\
 & \quad \left. \wedge \boxed{a_1} : c(\alpha) \wedge \dots \wedge \boxed{a_n} : c(\alpha) \right)
 \end{aligned}$$

The proposed theory also successfully accounts for an example like (2), which involves coordination of unlike predicates, when combined with Levine et al.’s theory of case syncretism (Levine et al. (2001)). Specifically, example (2) can be dealt with by introducing a new sort, say, *Acc-Dat*, as a subsort of both *Acc* and *Dat*, as shown in (13). (In this illustration, I ignore cases other than the accusative case and the dative case.)

²This lexical entry captures only the prescriptively “correct” case assignment pattern. Further complexity will have to be introduced into the lexical entry, if we are to capture prescriptively “incorrect” case assignment patterns, described in detail in Sobin (1997).

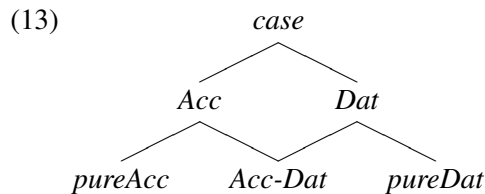

Since the VALENCE value of the coordinate structure *gefunden und geholfen* in (2) is by assumption identical both to the VALENCE value of *gefunden* and to the VALENCE value of *geholfen*, it is correctly predicted that the coordinate structure subcategorizes for an NP whose CASE value is *Acc-Dat*, provided that *gefunden* subcategorizes for an NP whose CASE value is *Acc* and *geholfen* subcategorizes for an NP whose CASE value is *Dat*.

The theory proposed here provides us with a means to capture the contrast illustrated in (14) below, noted in Büring (2002).

- (14) a. one of us/*one of you and me
 b. one of the detectives/*one of Schimansky and Tanner

On the proposed account, it is possible to distinguish the grammatical cases and the ungrammatical cases by stipulating that this use of *of* subcategorizes for a plural NP or a coordinate structure made up of plural NPs, and not for a coordinate structure made up of singular NPs. Such a straightforward account is not available in other theories, where a phrase of the form [NP_{SING} and NP_{SING}] is (or at least can be) given the same status as a plural NP.

The following example is a potential problem for the proposed theory. (I owe this observation to Carl Pollard (personal communication).)

- (15) Ken wants [to go to Berlin] and [for Jane to visit the city as well].

Since the proposed theory requires that the conjuncts of a coordinate structure should share the identical VALENCE value, this example is wrongly predicted to be ungrammatical, as long as we adhere to the standard HPSG analysis in which the first conjunct *to go to Berlin* is a VP while the second conjunct *for Jane to visit the city as well* is a saturated clause. In order to get around this potential problem, I assume here that the SUBJ list of the infinitival verb *go*, as well as the SUBJ list of the word *to*, is lexically specified to be an empty list, and that the first conjunct *to go to Berlin* in the above example is thus in fact a saturated clause, not a VP. Furthermore, in order to prevent this assumption from causing problems regarding our analysis of raising and control, I suggest that we adopt the theory, endorsed by Meurers (1999), Levine (2001), and others, in which a HEAD feature called SUBJECT, whose value is structure-shared with the least oblique element on the head's argument-structure list, makes information about the subject NP accessible to raising and control verbs.

4 Right-node raising

In this section, I will show how the present theory accounts for the grammaticality of (3) and (4), which was identified as a problem for Bayer's theory.

The grammaticality of examples like (3) and (4) is in fact no mystery if we adopt a theory of right-node raising (RNR) such as the one presented in Yatabe (2001), according to which there are two types of RNR: a syntactic type of RNR, which applies to two or more homophonic conjunct-final expressions only when they share the same syntactic and semantic internal structure, and a purely prosodic type of RNR, which is allowed to apply to two or more homophonic conjunct-final elements that may not share the same syntactic and semantic internal structure. On this account, two homophonous words, such as the words *Dozenten* 'docent' and *Dozenten* 'docents' or the words *Quark* 'quark' and *Quark* 'fresh cheese', are allowed to undergo the latter, purely prosodic type of RNR and give rise to sentences like (3) and (4), even though they are syntactically and semantically distinct and thus are not allowed to undergo the former, syntactic type of RNR. The Finnish example in (16) is amenable to the same explanation; it can also be viewed as resulting from the purely prosodic type of RNR.

- (16) He lukivat hänen uusimman _____ ja me hänen parhaat _____
they read his newest (sg gen) and we his best (pl nom)
kirjansa.
book/books
(from Zaenen and Karttunen (1984))

It might be felt that an account like this would inevitably lead to massive over-generation. That is not the case. Most potential cases of purely prosodic RNR can be blocked by the following constraint, which is probably reducible to principles governing the interpretation of focus and hopefully need not be stated as an independent constraint.

- (17) The anti-focus constraint on right-node raising:
Expressions that are accented so as to be interpreted as contrasting with each other cannot be fused with each other.

This constraint prevents the sentence (18b) from being derived from (18a) through application of the purely prosodic type of RNR.

- (18) a. Jo has visited [THAT city]₁ and Ed is going to visit [THAT city]₂.
([THAT city]₁ ≠ [THAT city]₂)
b. Jo has visited and Ed is going to visit THAT city.

The NPs [THAT city]₁ and [THAT city]₂ in (18a) are accented so as to be interpreted as contrasting with each other. Therefore, due to the anti-focus constraint on RNR, the two NPs cannot be fused together and right-node-raised.

Examples like (3) and (4) are special cases. In the ‘pre-RNR stage’ of (3) (that is, ‘der Antrag des Dozenten oder der Dozenten’), the contrast between the singular ‘docent’ and the plural ‘docents’ is signaled not by accenting the nouns themselves but rather by accenting the preceding determiners. Likewise, in the ‘pre-RNR stage’ of (4) (that is, ‘Peter beschreibt den Quark, und Martin beschreibt das Quark’), the contrast between ‘quark’ and ‘fresh cheese’ is indicated not by accenting the nouns themselves but by accenting the preceding determiners.³ Purely prosodic RNR can be used only in exceptional cases such as these.

5 Each-conjunct agreement

In this penultimate section, I will present an analysis of subject-verb agreement in English, in order to show how the proposed theory provides a basis for a principled characterization of the phenomenon of each-conjunct agreement, which was identified as a problem for Sadler’s theory.

The analysis that I suggest consists of the following hypotheses. I will simply describe the hypotheses first, and will try to motivate each afterwards.

Hypothesis 1:

VPs and NPs are both equipped with a HEAD feature called AGR.

Hypothesis 2:

Subject-verb agreement is enforced by requiring a certain relation to hold between the HEAD values (including the HEAD|AGR values) of a VP and its subject.⁴

Hypothesis 3:

Nouns can be constructed on the fly which end with a plurality marker (-s) but whose SYNSEM|CAT|HEAD|AGR|NUM value is *singular*.

Hypothesis 4:

There are (at least) two lexical entries for the word *and*, both of which can be used to conjoin NPs: one entry whose function is to form an NP with a plural index and another one whose function is to form an NP with a singular index.

Hypothesis 5:

The HEAD|AGR value of a verb is atomic and is required to be of type *v-agr-cat*. The type *v-agr-cat* consists of six immediate subtypes, *3sing*, *non-3sing*, *any*, *am*, *was*, and *are-were*, which are all leaf types. The value *3sing* is assigned to verbs like *is* and *walks*, *non-3sing* to

³I have been unable to determine if something analogous can be said about (16).

⁴The way this relation is to be integrated into the grammar is discussed in detail in Yatabe (2003), and will not be elaborated on in this paper.

verbs like the finite *walk*, *any* to verbs like *walked* and the infinite *walk*, *am* to the verb *am*, *was* to the verb *was*, and *are-were* to the verbs *are* and *were*. On the other hand, the AGR value of a noun is a feature structure that has three features, NUM, PER, and GEND.

Hypothesis 6:

The relation that is required to hold between the HEAD values (including the HEAD|AGR values) of a VP and its subject, which I will call the *subject_verb_agreement* relation, is defined as follows. The two arguments of this relation are the HEAD values of a VP and its subject, respectively.

$$\begin{aligned} & \text{subject_verb_agreement}(\boxed{1}, \boxed{2}) \equiv \\ & \quad \text{subj_v_agr}(\boxed{1}, \boxed{2}) \\ \vee & \left(\begin{array}{l} \boxed{1} : [\text{ARGS} \langle \boxed{a_1}, \dots, \boxed{a_n} \rangle] \\ \wedge \left(\text{subject_verb_agreement}(\boxed{a_1}, \boxed{2}) \wedge \dots \right. \\ \quad \left. \wedge \text{subject_verb_agreement}(\boxed{a_n}, \boxed{2}) \right) \end{array} \right) \end{aligned}$$

The *subj_v_agr* relation, which is utilized in this definition, is defined as follows:

$$\begin{aligned} & \text{subj_v_agr}(\boxed{1}, \boxed{2}) \equiv \\ & \quad \left(\begin{array}{l} \boxed{1} : [\text{AGR } 3\text{sing}] \\ \wedge \left(\text{person}(\boxed{2}, 3\text{rd}) \wedge \text{number}(\boxed{2}, \text{sing}) \right) \end{array} \right) \\ \vee & \left(\begin{array}{l} \boxed{1} : [\text{AGR } \text{non-3sing}] \\ \wedge \left(\text{person}(\boxed{2}, 1\text{st}) \vee \text{person}(\boxed{2}, 2\text{nd}) \vee \text{number}(\boxed{2}, \text{pl}) \right) \end{array} \right) \\ \vee & \quad \boxed{1} : [\text{AGR } \text{any}] \\ \vee & \left(\begin{array}{l} \boxed{1} : [\text{AGR } \text{am}] \\ \wedge \left(\text{person}(\boxed{2}, 1\text{st}) \wedge \text{number}(\boxed{2}, \text{sing}) \right) \end{array} \right) \\ \vee & \left(\begin{array}{l} \boxed{1} : [\text{AGR } \text{was}] \\ \wedge \left(\left(\text{person}(\boxed{2}, 1\text{st}) \vee \text{person}(\boxed{2}, 3\text{rd}) \right) \wedge \text{number}(\boxed{2}, \text{sing}) \right) \end{array} \right) \\ \vee & \left(\begin{array}{l} \boxed{1} : [\text{AGR } \text{are-were}] \\ \wedge \left(\text{person}(\boxed{2}, 2\text{nd}) \vee \text{number}(\boxed{2}, \text{pl}) \right) \end{array} \right) \\ \vee & \left(\begin{array}{l} \boxed{2} : \left[\begin{array}{l} \text{CONJ} \quad \text{or} \\ \text{ARGS} \quad \langle \boxed{a_1}, \dots, \boxed{a_n} \rangle \end{array} \right] \\ \wedge \left(\text{subj_v_agr}(\boxed{1}, \boxed{a_1}) \wedge \dots \wedge \text{subj_v_agr}(\boxed{1}, \boxed{a_n}) \right) \end{array} \right) \end{aligned}$$

The *number* relation, which appears in the above definition, is defined as follows. (The definition of the *person* relation is given in the Appendix.)

$$\text{number}(\boxed{1}, \boxed{2}) \equiv$$

$$\begin{array}{l}
\vee \left(\begin{array}{l} \boxed{1} : [\text{AGR} \mid \text{NUM} \ \boxed{2}] \\ \boxed{1} : [\text{CONJ} \ \textit{singular-and}] \end{array} \wedge \boxed{2} = \textit{sing} \right) \\
\vee \left(\begin{array}{l} \boxed{1} : [\text{CONJ} \ \textit{plural-and}] \\ \boxed{1} : [\text{CONJ} \ \textit{plural-and}] \end{array} \wedge \boxed{2} = \textit{pl} \right)
\end{array}$$

Hypothesis 1 was first proposed by Kathol (1999) and has been adopted by Bender and Flickinger (1998), Sag et al. (2003), and others. I take this hypothesis to be relatively uncontroversial, if not universally accepted.

Hypothesis 2 is essentially what has been proposed by Kathol (1999) for subject-verb agreement in German. Kathol, however, chooses not to analyze subject-verb agreement in English in the same way. He instead maintains the analysis proposed in Pollard and Sag (1994), which treats subject-verb agreement in English as index agreement; he assumes that what is involved in subject-verb agreement in English is agreement between the AGR value of a verb phrase and the INDEX value of its subject. The reason I do not accept this aspect of Kathol's analysis is the following. In the theory of constituent coordination proposed in section 3, the HEAD value (including the HEAD|AGR value) of each conjunct remains accessible at the level of the coordinate structure by being incorporated into the HEAD value of the coordinate structure as a whole. The INDEX value of each conjunct, on the other hand, is not accessible at the level of the coordinate structure. Therefore it will not be possible to capture the patterns of each-conjunct agreement within this theory if the principles governing subject-verb agreement in English are to make reference to the INDEX value of the agreement source, rather than its AGR value. Given this state of affairs, it seems at least as reasonable to explore an alternative analysis of subject-verb agreement in English as it is to modify and complicate the theory of coordination.

Hypothesis 3 makes it possible for the proposed theory to deal with examples like (19), discussed in Pollard and Sag (1994).

(19) The hash browns at table nine is getting angry.

Pollard and Sag (1994) cite this example as evidence for the view that subject-verb agreement in English is index agreement. However, if we assume that the AGR|NUM value of the word *hash browns* here can be *singular*, then the example no longer contradicts the view that subject-verb agreement in English is agreement between the AGR values of a verb and its subject, just as subject-verb agreement in German appears to be.

Likewise, Hypothesis 4 makes it possible for the proposed theory to handle examples like the following. (The two conjoined NPs *his aged servant* and *the subsequent editor of his collected papers* in (21) are intended to refer to the same individual.)

(20) Mary and John were criticizing themselves.

(21) His aged servant and the subsequent editor of his collected papers was with him at his deathbed. (from Quirk et al. (1985) (§10.39))

Example (20) shows that when two NPs with different indices are conjoined with *and*, the resulting coordinate NP functions as something plural. Example (21), on the other hand, shows that when two NPs with the same index are conjoined with *and*, the resulting coordinate NP functions as something singular. Pollard and Sag (1994) use examples of this type as another piece of evidence for the view that subject-verb agreement in English is index agreement. However, it is possible to reinterpret these facts in the following way, given Hypothesis 4. The word *and* in (20) and the word *and* in (21) are in fact different words with different meanings. Let us refer to the predicate expressed by the former as *plural-and* and to the predicate expressed by the latter as *singular-and*. Then the HEAD|CONJ value of the subject NP in (20) would be *plural-and*, whereas the HEAD|CONJ value of the subject NP in (21) would be *singular-and*; the difference between the agreement properties of the two subject NPs can now be ascribed to the difference between these two HEAD|CONJ values, rather than the difference between their INDEX values.⁵

Hypothesis 5 says nothing new about the AGR values of NPs; on the other hand, what it says about the AGR values of verbs is novel. In the standard analysis of the phenomenon, subject-verb agreement in English is assumed to be enforced by a constraint that requires the “phi-feature specifications” of a verb and those of its subject to be identical. This standard analysis, however, cannot be maintained, in view of the fact that subject-verb agreement in English resorts to the pattern of each-conjunct agreement at times.⁶ Consider example (8b) (*You or I must be wrong*). If we were to treat the agreement between *must* and its subject in this sentence in terms of simple identity requirements, we would have to say that there was a type, say *1st-2nd*, which was a subtype of both *1st* and *2nd*, and that the PER value of the verb *must*, that of the first conjunct *you*, and that of the second conjunct *I* were all *1st-2nd*. While it might not be so strange to say that the PER value of the verb is *1st-2nd*, it is plainly absurd to say that the PER value of the pronoun *I* or that of the pronoun *you* is *1st-2nd*; to say that would be to say that *I* is actually not just a first-person pronoun but also a second-person pronoun and that *you* is actually not just a second-person pronoun but also a first-person pronoun.

The definition of the *subject_verb_agreement* relation in Hypothesis 6 merely says that a VP must agree with its subject and that, when the VP is a (possibly nested) coordinate structure, each conjunct must agree with the subject. The next definition, the definition of the *subj_v_agr* relation, is the central piece of this analysis of subject-verb agreement. There are seven disjuncts in the right-hand side of the definition of the *subj_v_agr* relation; the seventh disjunct deals with each-

⁵It is probably necessary to say that there are two types of *or* too, since sentences like *Either Fred or Bill are shaving themselves* are possible as well as sentences like *Either Fred or Bill is shaving himself* (Quirk et al. (1985); Peterson (1986)). This complication will be ignored in this paper. What I call summative agreement in Yatabe (2003) will likewise be ignored.

⁶Ingria (1990) also argues against what I call the standard analysis here. Most if not all of his arguments lose force, however, given the analysis of case syncretism developed in Levine et al. (2001) and the notion of purely prosodic RNR, both of which were mentioned earlier.

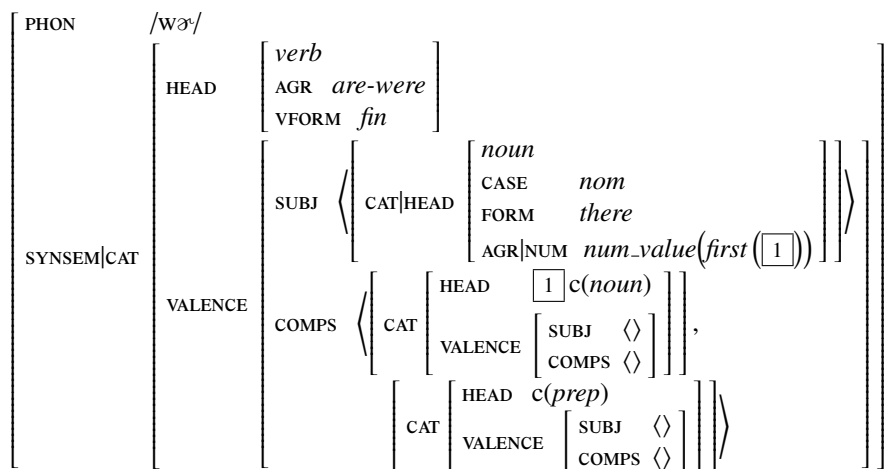

Figure 4: Part of a lexical entry that will give rise to the *there* construction

conjunct agreement and the other six disjuncts deal with the rest of the cases. The *number* relation, which is defined next, is, intuitively speaking, a relation that holds between *X* and *sing* (or *pl*) if and only if *X* can be regarded as something singular (or plural, respectively). Recall that *plural-and* and *singular-and* are the names of the relations expressed by the two lexical entries for *and* mentioned above.

All in all, the proposed theory successfully describes subject-verb agreement in English, including cases involving each-conjunct agreement. The analysis presented in this section is more complicated than many of the analyses that it is intended to supersede, and the same can be said about the analysis of single-conjunct agreement that is going to be presented in the next section. It should be recalled, however, that none of the previous theories is equipped with an adequate analysis of both each-conjunct agreement and single-conjunct agreement.

6 Single-conjunct agreement

In this final section, I will present an analysis of the *there* construction in English, in order to show how the proposed theory can deal with single-conjunct agreement, a phenomenon that was identified as a problem for Bayer's theory.

The reason why the proposed theory is capable of dealing with single-conjunct agreement is that the linear order between conjuncts is reflected in the HEAD value of the coordinate structure as a whole. The facts shown in (5) can be captured by setting up lexical entries like the one shown in Figure 4. The *num_value* function and the *first* function that are used in this lexical entry are defined as follows.

$$(22) \text{ num_value}(\left[\text{AGR|NUM} \begin{array}{|c|} \hline 1 \\ \hline \end{array} \right]) \equiv \begin{array}{|c|} \hline 1 \\ \hline \end{array}$$

$$(23) \text{ first}(\boxed{1}) \equiv \begin{cases} \text{first}(\boxed{a_1}), & \text{if } \boxed{1}: [\text{ARGS} \langle \boxed{a_1} \cdots \boxed{a_n} \rangle] \\ \boxed{1}, & \text{otherwise} \end{cases}$$

The lexical entry in Figure 4 says (i) that the AGR|NUM value of the subject NP *there* must be identical to the AGR|NUM value of the postverbal NP when the postverbal NP is not a coordinate structure, and (ii) that the AGR|NUM value of the subject NP *there* must be identical to the AGR|NUM value of the leftmost conjunct in the postverbal NP when the postverbal NP is a possibly nested coordinate structure. This is an adequate description of what we see in examples like (5).

The following observation, due to Morgan (1984), poses a potentially serious problem for the proposed analysis.

- (24) a. There were two women and a man sunning themselves on the patio.
 b. There ??was/??were a man and two women sunning themselves on the patio.

There is nothing wrong with (24a). In (24b), on the other hand, *was* cannot be used, presumably because the clause-final VP *sunning themselves on the patio* requires a plural subject, and *were* cannot be used either, presumably because the verb is required to agree with the immediately postverbal NP (*a man*), which happens to be singular. These facts seem to justify the following generalization, explicitly stated in Sadler (2003): in English, “once a particular set of feature values has been associated with the coordinate NP as a whole, all agreement processes access these same values.” The problem here is that the theory proposed in this paper does not associate any particular agreement-related feature values to a coordinate NP as a whole and hence does not provide a natural way to state this generalization.

The examples above, however, do not confirm the correctness of the generalization in question. The facts can be captured by setting up a lexical entry like the one in Figure 5, without the help of the generalization. The lexical entry in Figure 5 rules out the *was* version of (24b) by requiring that the AGR|NUM value of *there* (which is required to be *sing* by the AGR value of the verb and the AGR|NUM value of the first conjunct of the postverbal NP) should be identical to the AGR|NUM value of the unexpressed subject of the clause-final VP (which is required to be *pl* by the presence of the plural reflexive pronoun). The *were* version of (24b) is also ruled out, because the first conjunct of the postverbal NP, which is required to be plural by the AGR value of the verb, is in fact singular. Thus the examples do not provide a reason to accept the problematic generalization.⁷

⁷Sadler (2003) uses examples like *Either Fred or Bill is shaving himself/*themselves* and *Either Fred or Bill are shaving themselves/*himself* (Peterson (1986)), in justifying the generalization in question. These examples do not pose a problem for the proposed theory either, provided that, as suggested in note 5 above, there are two types of *or*, one producing NPs that agree with singular verbs and singular pronouns and one that produces NPs that agree with plural verbs and plural pronouns. Incidentally, it should be pointed out that the generalization in question, if true, would pose a problem for Sadler’s theory as well. In Sadler’s theory, the generalization means that, unlike Welsh, English

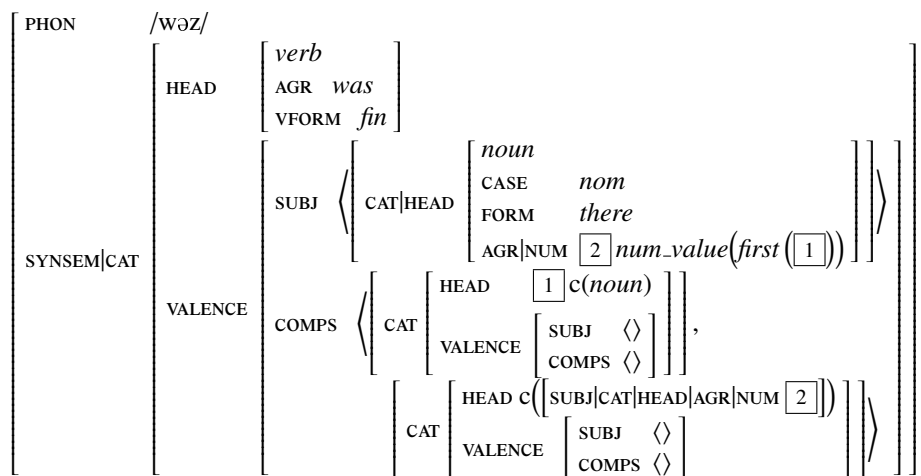

Figure 5: Part of another lexical entry that will give rise to the *there* construction

7 Conclusion

In this paper, it has been argued that it is possible to develop a reasonably simple HPSG-based theory that is capable of dealing with every phenomenon resulting from coordination of unlikes, including single-conjunct agreement and each-conjunct agreement. In the course of the argumentation, it has also been claimed that certain facts involving each-conjunct agreement provide a straightforward piece of evidence that subject-verb agreement in English must be characterized in terms of relational constraints that are not simply identity requirements.

Appendix

The *person* relation, which is referred to in the definition of the *subj_v_agr* relation in section 5, is defined as follows.

$$\begin{aligned}
 & person([1], [2]) \equiv \\
 & \quad [1] : [AGR|PER [2]] \\
 \vee & \quad \left([2] = Ist \right. \\
 & \quad \wedge [1] : \left[\begin{array}{l} CONJ [3] \\ ARGS \langle a_1, \dots, a_n \rangle \end{array} \right] \\
 & \quad \wedge [3] \neq or
 \end{aligned}$$

has only one agreement-related feature or that the AGR value and the INDEX value of an NP are always required to be identical to each other in English. This leads to the following problem. The sentence *There was a man and two women in the room* is grammatical in English. Therefore it must be the case that the NUM value of the NP *a man and two women* can be *sing*. Then why can we not say something like **A man and two women was running around?*

$$\begin{aligned}
& \wedge \left(person(\boxed{a_1}, Ist) \vee \dots \vee person(\boxed{a_n}, Ist) \right) \\
\vee & \left(\begin{array}{l} \boxed{2} = 2nd \\ \wedge \boxed{1} : \left[\begin{array}{l} \text{CONJ } \boxed{3} \\ \text{ARGS } \langle \boxed{a_1}, \dots, \boxed{a_n} \rangle \end{array} \right] \\ \wedge \boxed{3} \neq or \\ \wedge \left(person(\boxed{a_1}, 2nd) \vee \dots \vee person(\boxed{a_n}, 2nd) \right) \\ \wedge \neg \left(person(\boxed{a_1}, Ist) \vee \dots \vee person(\boxed{a_n}, Ist) \right) \end{array} \right) \\
\vee & \left(\begin{array}{l} \boxed{1} : \left[\text{ARGS } \langle \boxed{a_1}, \dots, \boxed{a_n} \rangle \right] \\ \wedge \left(person(\boxed{a_1}, \boxed{2}) \wedge \dots \wedge person(\boxed{a_n}, \boxed{2}) \right) \end{array} \right)
\end{aligned}$$

References

- Bayer, Samuel. 1996. The Coordination of Unlike Categories. *Language* 72, 579–616.
- Beavers, John and Sag, Ivan A. 2004. Some Arguments for Coordinate Ellipsis in HPSG. Paper Presented at the HPSG 2004 Conference.
- Bender, Emily and Flickinger, Dan. 1998. Peripheral Constructions and Core Phenomena: Agreement in Tag Questions. In Gert Webelhuth, Jean-Pierre Koenig and Andreas Kathol (eds.), *Lexical and Constructional Aspects of Linguistic Explanation*, pages 199–214, Stanford: CSLI.
- Büring, Daniel. 2002. $2 \times \text{Singular} \neq \text{Plural}$. *Snippets* 6, 6–7, <http://www.ledonline.it/snippets/>.
- Crysmann, Berthold. 2003. An Asymmetric Theory of Peripheral Sharing in HPSG: Conjunction Reduction and Coordination of Unlikes. In Gerhard Jäger, Paola Monachesi, Gerald Penn and Shuly Wintner (eds.), *Proceedings of Formal Grammar 2003*, pages 47–62, available at <http://cs.haifa.ac.il/~shuly/fg03/>.
- Dalrymple, Mary and Kaplan, Ronald M. 2000. Feature Indeterminacy and Feature Resolution. *Language* 76, 759–798.
- Daniels, Michael W. 2002. On a Type-Based Analysis of Feature Neutrality and the Coordination of Unlikes. In Frank Van Eynde, Lars Hellan and Dorothee Beermann (eds.), *Proceedings of the 8th International Conference on Head-Driven Phrase Structure Grammar*, pages 137–147, Stanford: CSLI, <http://csli-publications.stanford.edu/HPSG/>.
- Doron, Edit. 2000. VSO and Left-Conjunct Agreement: Biblical Hebrew vs. Modern Hebrew. In Andrew Carnie and Eithne Guilfoyle (eds.), *The Syntax of Verb Initial Languages*, Oxford Studies in Comparative Syntax, pages 75–95, Oxford: Oxford University Press.

- Eisenberg, Peter. 1973. A Note on “Identity of Constituents”. *Linguistic Inquiry* 4, 417–420.
- Hartmann, Katharina. 2000. *Right Node Raising and Gapping: Interface Conditions on Prosodic Deletion*. Amsterdam: John Benjamins.
- Ingria, Robert J. P. 1990. The Limits of Unification. In *Proceedings of the 28th Annual Meeting of the Association for Computational Linguistics*, pages 194–204.
- Kathol, Andreas. 1999. Agreement and the Syntax-Morphology Interface in HPSG. In Robert D. Levine and Georgia M. Green (eds.), *Studies in Contemporary Phrase Structure Grammar*, pages 223–274, Cambridge: Cambridge University Press.
- Levine, Robert D. 2001. Tough Complementation and the Extracausal Propagation of Argument Descriptions. In Dan Flickinger and Andreas Kathol (eds.), *Proceedings of the 7th International Conference on Head-Driven Phrase Structure Grammar*, pages 214–228, Stanford: CSLI, <http://csli-publications.stanford.edu/HPSG/>.
- Levine, Robert D., Hukari, Thomas E. and Calcagno, Michael. 2001. Parasitic Gaps in English: Some Overlooked Cases and Their Theoretical Implications. In Peter W. Culicover and Paul M. Postal (eds.), *Parasitic Gaps*, pages 181–222, Cambridge, Massachusetts: MIT Press.
- Levy, Roger and Pollard, Carl. 2002. Coordination and Neutralization in HPSG. In Frank Van Eynde, Lars Hellan and Dorothee Beermann (eds.), *Proceedings of the 8th International Conference on Head-Driven Phrase Structure Grammar*, pages 221–234, Stanford: CSLI, <http://csli-publications.stanford.edu/HPSG/>.
- Maxwell III, John T. and Manning, Christopher D. 1996. A Theory of Non-constituent Coordination based on Finite-State Rules. In Miriam Butt and Tracy Holloway King (eds.), *Proceedings of the LFG '96 Conference*, Stanford: CSLI, <http://csli-publications.stanford.edu/LFG/>.
- Meurers, Walt Detmar. 1999. Raising Spirits (and assigning them case). *Groninger Arbeiten zur Germanistischen Linguistik (GAGL)* 43, 173–226.
- Moosally, Michelle, J. 1999. Subject and Object Coordination in Ndebele: An HPSG Analysis. In Sonya Bird, Andrew Carnie, Jason D. Haugen and Peter Norquest (eds.), *Proceedings of the 18th West Coast Conference on Formal Linguistics*, pages 379–392, Somerville: Cascadilla Press.
- Morgan, Jerry L. 1984. Some Problems of Agreement in English and Albanian. In Claudia Brugman and Monica Macaulay (eds.), *Proceedings of the Tenth Annual Meeting of the Berkeley Linguistics Society*, pages 233–247, Berkeley: BLS.

- Munn, Alan. 2000. Three Types of Coordination Asymmetries. In Kerstin Schwabe and Ning Zhang (eds.), *Ellipsis in Conjunction*, pages 1–22, Tübingen: Niemeyer.
- Peterson, Peter G. 1986. Establishing Agreement with Disjunctively Conjoined Subjects: Strategies vs Principles. *Australian Journal of Linguistics* 6, 231–249.
- Peterson, Peter G. 2004. Coordination: Consequences of a Lexical-Functional Account. *Natural Language and Linguistic Theory* 22, 643–679.
- Pollard, Carl and Sag, Ivan A. 1994. *Head-Driven Phrase Structure Grammar*. Chicago: University of Chicago Press.
- Pullum, Geoffrey K. and Zwicky, Arnold M. 1986. Phonological Resolution of Syntactic Feature Conflict. *Language* 62, 751–773.
- Quirk, Randolph, Greenbaum, Sidney, Leech, Geoffrey and Svartvik, Jan. 1985. *A Comprehensive Grammar of the English Language*. London: Longman.
- Sadler, Louisa. 2003. Coordination and Asymmetric Agreement in Welsh. In Miriam Butt and Tracy Holloway King (eds.), *Nominals: Inside and Out*, pages 85–117, Stanford: CSLI.
- Sag, Ivan A. 2003. Coordination and Underspecification. In Jong-Bok Kim and Stephen Wechsler (eds.), *Proceedings of the 9th International Conference on Head-Driven Phrase Structure Grammar*, pages 267–291, Stanford: CSLI, <http://csli-publications.stanford.edu/HPSG/>.
- Sag, Ivan A., Wasow, Thomas and Bender, Emily M. 2003. *Syntactic Theory: A Formal Introduction*. Stanford: CSLI, second edition.
- Sobin, Nicholas. 1997. Agreement, Default Rules, and Grammatical Viruses. *Linguistic Inquiry* 28, 318–343.
- Yatabe, Shûichi. 2001. The Syntax and Semantics of Left-Node Raising in Japanese. In Dan Flickinger and Andreas Kathol (eds.), *Proceedings of the 7th International Conference on Head-Driven Phrase Structure Grammar*, pages 325–344, Stanford: CSLI, <http://csli-publications.stanford.edu/HPSG/>.
- Yatabe, Shûichi. 2003. A Linearization-Based Theory of Summative Agreement in Peripheral-Node Raising Constructions. In Jong-Bok Kim and Stephen Wechsler (eds.), *Proceedings of the 9th International Conference on Head-Driven Phrase Structure Grammar*, pages 325–344, Stanford: CSLI, <http://csli-publications.stanford.edu/HPSG/>.
- Zaenen, Annie and Karttunen, Lauri. 1984. Morphological Non-Distinctiveness and Coordination. In Gloria Alvarez, Belinda Brodie and Terry McCoy (eds.), *Proceedings of the First Eastern States Conference on Linguistics*, pages 309–320.

Part II

Contributions to the Workshop

A treatment of directionals in two implemented HPSG grammars

Dorothee Beermann 

NTNU Trondheim

Lars Hellan 

NTNU Trondheim

Proceedings of the 11th International Conference on
Head-Driven Phrase Structure Grammar

Center for Computational Linguistics, Katholieke Universiteit Leuven

Stefan Müller (Editor)

2004

Stanford, CA: CSLI Publications

pages 357–377

Beermann, Dorothee & Lars Hellan. 2004. A treatment of directionals in two implemented HPSG grammars. In Stefan Müller (ed.), *Proceedings of the 11th International Conference on Head-Driven Phrase Structure Grammar*, Center for Computational Linguistics, Katholieke Universiteit Leuven, 357–377. Stanford, CA: CSLI Publications. DOI: 10.21248/hpsg.2004.20. 

Abstract

This article proposes a semantics of directional expressions in Norwegian and German, regarded as VP modifiers. The analysis uses Minimal Recursion Semantics, as an integrated part of the HPSG Grammar Matrix-backbone. Directional expressions are analyzed as predicating of an individual, the 'mover'. Context dependent directionals like *here* receive a decomposed analysis. Telicity values reflecting the presence of various types of directional and locative expressions are computed.

1 Introduction

We here report on an implementational approach whose main goal is to explore the incorporation of *lexical semantics* as part of the semantic interface of grammars with standard design. The grammars in question cover Norwegian and German, and are based on the *HPSG Grammar Matrix* (henceforth: the Matrix).¹ Both grammars are distinct from existing larger grammars for the same languages, allowing some experimental flexibility not readily available in larger grammars. We will show that with a rather modest supply of resources for the encoding of semantic information, we are able to compute aspectual values for directional and other constructions of some complexity, and to perform some amount of semantic decomposition reflecting the presence of multiple parameters encoded in locative and directional adverbs.²

Section 2 gives a background introduction to the formal basis of our proposal, and in particular to the representational format of *Minimal Recursion Semantics* (MRS) and how it is integrated in the grammar formalism.

In section 3 we discuss three domains for which we would like to suggest a more pronounced semantics than so far provided in the most developed HPSG grammars (those for English, Japanese and German): these domains are directionals, locative anaphors such as 'here', 'there', etc., and aspect specification.

Section 4 exposes the formal analysis of the phenomena presented in section 3, and in section 5 we provide some expansions of the analysis and some discussion.

¹ (Bender, Flickinger and Open 2002, Bender and Flickinger 2003, Flickinger, Bender and Open 2003). Based essentially on the *ERG (English Resource Grammar)* (Flickinger 2000), and also JACY (Siegel and Bender, 2002), the Matrix provides types inducing a system of typed feature structures, the essential lexical and syntactic types, together with MRS representations. Grammars of some size developed from the Matrix include Norwegian (Hellan and Haugereid 2003), Italian (Gonella and Mazzini 2003), Spanish, Korean and Greek.

² The grammars in question have been built into a small end-to-end application for extracting information from hiking route descriptions for use in a web portal for hiking route queries, called 'Trailfinder' (cf. Beermann, Gulla, Hellan and Prange 2004).

2 Minimal Recursion Semantics in a Matrix grammar

The main format of semantic representation in a Matrix grammar is MRS (cf. Copestake et al. 2003, Flickinger et al. 2003). MRS representations are designed to represent in 'flat' structures the embedding of scopal relations as found in standard logical and semantic formalisms, with an expressive capacity at least that of predicate logic. As currently used, MRS representations accommodate argument structure information, variable binding, scope of quantifiers and other operators. The interaction between grammatical specification and MRS representations (using Matrix.0.5) can be partly seen from (1) and (2) below, where the lexical specification of the verb *throw*, represented in (1), is reflected in the MRS produced for the sentence *the boy throws the ball* ((2)):

(1) Feature structure description for the lexical item *throw*:

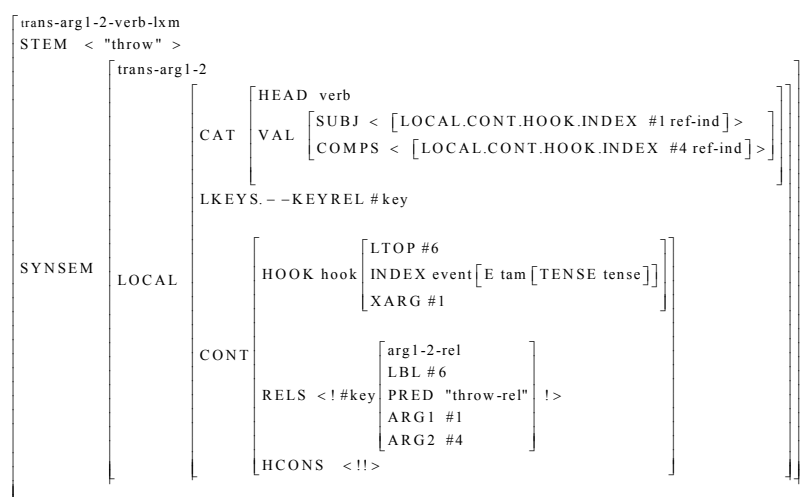

(2) MRS for the sentence *The boy throws the ball*:

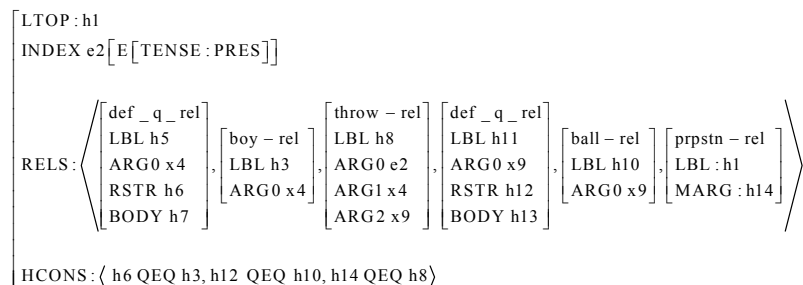

In accordance with a standard MRS set up as illustrated in (2), for any constituent *C* (of any rank), the RELS list in its CONT specification is a 'bag' of those elementary predications (EPs) which are expressed inside *C*. Lexical specifications are standardly not decomposed and in most cases introduce one EP, labelled according to the stem form. In a lexical specification like that for *throw*, thus, there is one EP, entered as value of LKEYS--KEYREL, and reentered in the RELS list. In the build-up of larger constituents headed by *throw*, all elements on the daughters' RELS lists will be entered on the RELS list of the larger constituent, including the EP from *throws*'s RELS list. An example of such a larger constituent is the sentence *The boy throws the ball*, for which the RELS list displays six EPs, of which one reflects *throw*; cf. (2). Two EPs here reflect the subject argument of the verb, as is seen by the coindexation of the ARG1 of the verb and the ARG0 (corresponding to 'bound variable') of the determiner and the noun, and two EPs reflect the object argument, similarly indicated by variable identity; the remaining EP represents 'message type' (cf. Ginzburg and Sag (2001)). Scope properties are expressed in the HCONS list, 'x QEQ y' meaning essentially that x scopes over y. HCONS thus records the scopal tree of the constituent in question, as outlined in Copestake et al. (to appear).

3 Directional expressions

By 'directional expressions' (or simply 'directionals') for the three languages under consideration (Norwegian, German and English - note that we use English as exemplifying language unless a point specific to one of the other languages is made), we understand preposition-headed and adverb-headed expressions like *to the church*, *from here*, *through the park*, *up*, *up through the chimney*, etc. Such expressions can qualify either the subject of a sentence, as in

John ran from here to the church

or the object, as in

John threw the ball from here to the church.

We treat directionals as V- or VP- modifiers; this position is motivated in section 5.

For subject-oriented directionals, a well-known property is their impact on the *telicity* status of the modified VP: Expressions like *to the park* induce telicity, by the criterion of allowing combination with expressions like *in an*

hour, as opposed to *for an hour*, while expressions like *along the river* allow for *an hour* as a further qualifier, but disallow *in an hour*,³ thus:

- (3)
- a. *John ran to the church* *for two hours
in two hours
 - b. *John ran along the river* for two hours
*in two hours

Likewise, *place* adverbials align with *along the river*:

- c. *John ran in the wood* for two hours
*in two hours

To be noticed is that when both types are represented, it is the telicity-inducing type which prevails:

- d. *John ran along the river to the church* *for two hours
in two hours

The same distinctions apply to directional *adverbs*. These, however, unlike directional prepositions, carry inherent *contextual anchoring* of one sort or another. Consider the following pairs in Norwegian:⁴

- (4)
- a. 1. *hit* 'to here', as in *Gutten løper hit* ('the boy runs to-here')
boy-DEF run-PRES to-here
 - 2. *dit* 'to-there', as in *Gutten løper dit* ('the boy runs to-there')
 - b. 1. *opp* '(to) up', as in *Gutten hopper opp* ('the boy jumps up')
boy-DEF jump-PRES to-up
 - 2. *ned* '(to) down', as in *Gutten hopper ned* ('the boy jumps down')

What the pairs in (4) have in common is that they anchor the directionality relative to a contextual correlate given in the discourse. For sentences in isolation, such as (4a), this correlate is by default the *speaker*, the meaning in both cases being that the motion has as its *endpoint* a location related to the speaker - in (a.1) *close* to the speaker, in (a.2) (more) remote from the speaker.

³ Cf., e.g., Smith (1991, 1997).

⁴ We will not attempt to give an exhaustive picture of the usage of the various adverbs and prepositions of Norwegian. Thus, for instance, we ignore those occurrences of 'place' adverbs where they function as predicatives (and then presumably as participant predicators), as in (i):

(i) Jon satte vasen her
Jon put the vase here

In (4b), an endpoint is again expressed, but in these constructions, the correlate can be any given *landmark* (not excluding the speaker), so that in (b.1), the endpoint of the motion is *high* relative to that landmark, in (b.2) *low*.

Exactly these same distinctions turn up in a series of corresponding *place* adverbs:

- (5)
- a.1. *her* 'here', as in *Gutten løper her* ('the boy runs here')
 - 2. *der* 'there', as in *Gutten løper der* ('the boy runs there')
 - b.1. *oppe* '(at) up(stairs)', as in *Gutten hopper oppe* ('the boy jumps up')
 - 2. *nede* '(at) down(stairs)', as in *Gutten hopper nede* ('the boy jumps down')

In (5), what is contextually correlated is not endpoints of movements, but places of events. Thus, the events in (5a) *take place* in locations related to the speaker, and in (5b) related to some discourse-salient landmark.

As exemplified by (4b) vs. (5b), the contrast between event/place modifying adverbs and participant modifying adverbs is morphologically flagged in most cases by the absence vs. presence of a word final *-e*. This contrast holds systematically in Norwegian, and is further exemplified in (6), with (a) as directional adverbs, (b) as place adverbs:

- (6)
- a.
 - 1. *bort* '(to) away', as in *Gutten løper bort* ('the boy runs away')
 - 2. *vekk* '(to) away', as in *Gutten løper vekk* ('the boy runs away')
 - 3. *ut* '(to) out', as in *Gutten løper ut* ('the boy runs out')
 - 4. *inn* '(to) in', as in *Gutten løper inn* ('the boy runs in')
 - 5. *hjem* '(to) home', as in *Gutten løper hjem* ('the boy runs home')
 - b.
 - 1. *borte* 'away', as in *Gutten er borte* ('the boy is away')
 - 2. *vekke* 'away', as in *Gutten er vekke* ('the boy is away')
 - 3. *ute* 'out(side)', as in *Gutten løper ute* ('the boy runs outside')
 - 4. *inne* 'in(side)', as in *Gutten løper inne* ('the boy runs inside')
 - 5. *hjemme* 'at home', as in *Gutten løper hjemme* ('the boy runs at home')

Corresponding to the directionals in (4) and (6a) is furthermore a series of 'along path' directionals, listed in (7):

- (7) *hitover* 'here-wards', as in *Gutten løper hitover* ('the boy runs herewards'); *ditover* 'there-wards'; *oppover* 'upwards'; *nedover* 'downwards'; *bortover* 'away'; *utover* 'outwards'; *innover* 'inwards'; *hjemover* 'home-wards'

The items in (7) differ from those in (4) and (6a) in that the ‘along-path’ concept, expressed by ‘over’, appears in a compound form together with the contextualized place morpheme. (7) is thus reminiscent of German contextualized directional adverbs such as ‘*hierher*’ ‘to here’ and ‘*dorthin*’ ‘to there’. Different from Norwegian, however, German also contextualizes the path description such that ‘*hierher*’ means towards the speaker seen from the speaker’s perspective and ‘*hierhin*’ means towards the speaker seen from the hearer’s perspective. Common to all of these adverbs is that the orientation of the movement relates to some contextually understood entity or place. For all cases, we call this the *contextual correlate*.

In the case of the end-point directional adverbs and along-path directionals in this group, there are in effect *two* entities contextually invoked: the endpoint/path as such, and then the correlate relative to which the endpoint/path is situated (as higher than, lower than, close to, remote from, etc.). With a place adverb like *her*, in contrast, only *one* contextually invoked entity is relevant – in the default case the speaker, expressed as *close to* the event.

Cutting across the contextual correlate distinctions for adverbs is the value they induce for telicity: the end-of-path directionals induce telicity, the other two types not.

Prepositions, in contrast to the adverbs now illustrated, have no contextually determined inherent participants. In the other respects, they cross-classify like the adverbs (as exemplified above for English): directional prepositions can induce telicity, such as Norwegian *til*, German *zu* ('to'), or they contribute atelicity, such as Norwegian *langs*, German *entlang* ('along'); and in the latter respect, they group along with place prepositions. Intuitively speaking, the circumstance that prepositions are those words which govern an NP that explicitly indicates a correlate of movement or location, while adverbs are words lacking such an NP, will seem to match the contrast with regard to contextual determination: one might hypothesize that in their semantics, both prepositions and adverbs are two place relations, and that, in this domain, what characterizes adverbs is that their ‘semantic object’ is contextually induced, while for prepositions, it is syntactically induced. The analysis to be presented below implements this view.

Central to the analysis is also a distinction between directional PPs/adverbs and event modifiers in what they are taken as being predicated of. For Norwegian we saw already that a majority of contextualized adverbs reflect this distinction morphologically. For German, further compelling evidence for such a differentiation comes from the group of prepositions that either govern *accusative* or *dative* case, where the accusative evokes a directional interpretation while the *dative* case forces a 'locative' interpretation. This is illustrated in (8):

- (8) Case in German
- | | | | | |
|----|-------------------------------------|-------------|------------|---------|
| a. | Der | Junge rennt | in der | Kirche. |
| | The.NOM | boy runs | in the.DAT | church |
| | <i>The boy runs in the church.</i> | | | |
| b. | Der | Junge rennt | in die | Kirche. |
| | The.NOM | boy runs | in the.ACC | church |
| | <i>The boy runs into the church</i> | | | |

The implementation of this differentiation is laid out in 4.1 below.

4 Analysis

4.1 Modifier predication of a *participant* vs. modifier predication of an *event*

Implementations of VP-modifiers (like that found in the ERG) commonly construe them as *event modifiers*; thus, in the analysis of *John runs in the wood*, the PP *in the wood* is construed as predicated of the index associated with *run*, and, hence, of the index of the event as such. This analysis corresponds to a paraphrase such as 'John's running is in the wood'. Technically, the value of the ARG1 of the preposition is reentered with the event index (INDEX) of the verb, as illustrated in (9) below. The feature MOD here introduces the item *modified* by the preposition, i.e., the verb, and the value of ARG1 of the preposition is reentered with the INDEX value of the MOD item:

- (9) Feature structure description for the event modifier preposition *on*:

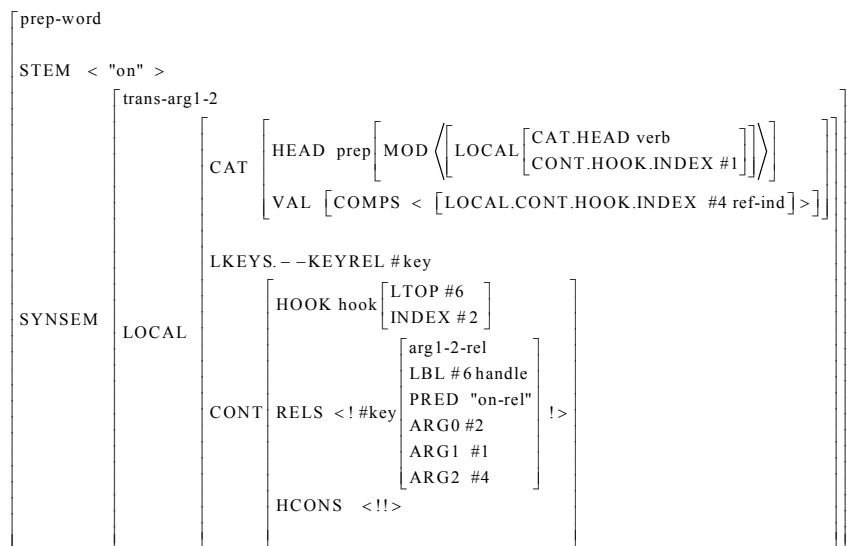

While grammars like ERG (as of 2003) extend this approach to directionals as well, an alternative treatment of directionals, which we will advocate here (and which is prevalent in much of the literature, e.g., Jackendoff (1990), is to construe directionals as predicated of *the mover*, i.e., the entity performing the directional motion. For *to* as in *John ran to the church*, this is to say that the ARG1 of the preposition is reentered with the ARG1 of the verb, rather than with its INDEX, and that in *John threw the ball to the church*, the ARG1 of the preposition is identical to the ARG2 of the verb. A similar contrast will be recognized for adverbs. We thereby implement the general contrast between event modifiers and directionals (illustrated, e.g., in (8) for German) as a difference in what the preposition's/adverb's ARG1 is coindexed with - the verb's INDEX for event modifiers, and one of the verb's arguments for directionals.

It might be asked if such selection information could alternatively be represented by a more morpho-syntactically flavoured feature, such as 'DIRECTIONAL *bool*'. Although a possibility in principle, we do not see any non-arbitrary way of making such an alternative marking. The proposal that the ARG1 of a preposition like *to* equals the ARG1 of the verb, and thus (in the standard case) is a *referential index*, in contrast, seems intuitively reasonable. It also receives some support from constructions like *The road goes to the church*, where, although the subject is not a mover, the phrase *to the church* clearly qualifies a 'thing'-like entity ('the road') rather than an event. This position will now be explicated and illustrated.

The analysis of *endpoint-of path* prepositions here proposed is illustrated in (10), for the Norwegian preposition *til* ('to'); this illustrates the approach we are taking. Crucial here is the identification of the preposition's ARG1 with the 'Mover' argument of the verb. As we have seen, the latter may be either an ARG1 or an ARG2, according to what type of verb it is - either one whose *subject* is a mover, or one whose *object* is what is set into motion, as for *kaste* ('throw'). The specification of *til* as such should be independent of this choice, i.e., of whether it qualifies a subject or an object. To implement such an independence, we enrich the semantic specification of the verb with a feature which exposes which of its arguments - if any - is a 'Mover', and make this index accessible to the preposition's MOD specification.

In the Matrix inventory of features, there is already one feature, XARG (for 'external argument'), at the path `SYNSEM|LOCAL|CONT|HOOK`, which serves for exposing arguments, e.g., for control specifications. All lexical items with predicative content have an XARG feature, and for verbs, it is typically the argument expressed by the *subject* which is exposed by this feature. Since a verb like *throw* will need XARG to expose its subject like all other verbs, this is not a feature that can be used for exposing a 'Mover' argument in general. We

therefore introduce a new feature for this purpose, called *DIRARG*.⁵ This is a feature which will be 'activated' only for verbs one of whose arguments performs a movement, and synsem-subtypes will be distinguished among both intransitive and transitive synsems, to accommodate the presence or absence of such an argument. The presence of this feature thereby serves as a mark of a 'motion-verb', and will be present whether or not a directional modifier actually occurs - it thus reflects an 'inherent' classification of verbs, according to their 'path'-taking potential. In (10), this feature is exposed inside the MOD specification of the preposition, analogously to where an event modifying preposition exposes INDEX as in (9):

- (10) Feature structure description for the preposition *til* ('to') as a participant modifier:

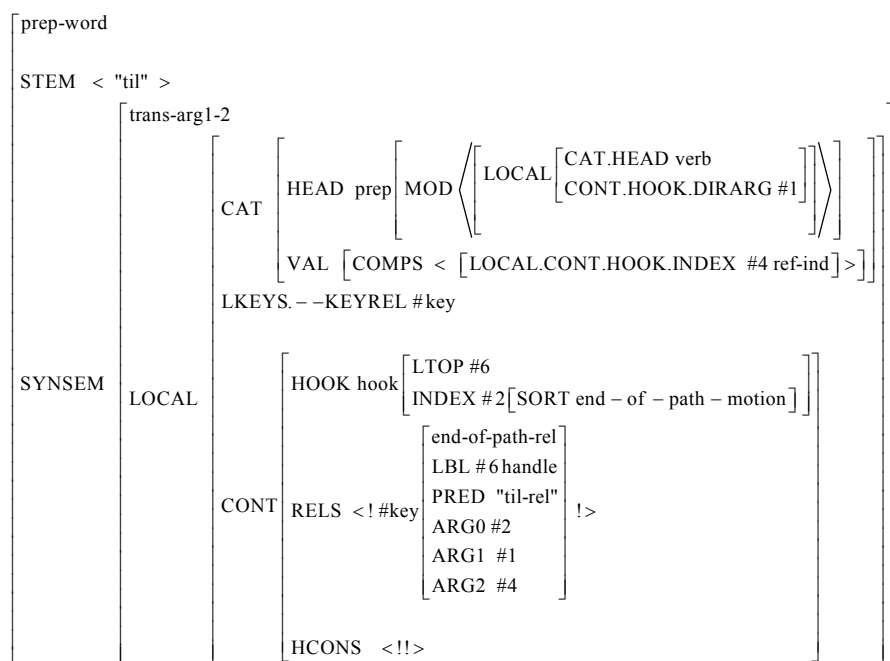

⁵ Technically, this is done by specifying a subtype of the type *hook* (the type which introduces the feature XARG - cf. (1)), and let this subtype - *dirhook* - introduce a feature DIRARG in addition to XARG. DIRARG will be activated by verbs expressing motion, in such a way that if it is the *subject* of the verb which performs the motion, then the verb's DIRARG = ARG1, and if it is the *object* of the verb which performs the motion, the verb's DIRARG = ARG2. These identities are encoded in the appropriate subtypes of intransitive and transitive verb SYNSEMS, respectively, while for *to*, its ARG1 will always be identical to the DIRARG of the verb, enforced by the specification under the MOD attribute of *to*, as seen in (10).

4.2 Inducing telicity values

The AVM in (10), in addition to elements explained above, also contains a specification for the attribute SORT. SORT is a feature inside the path of INDEX, allowing for further semantic specification of an item. In the present case, it introduces a specification *end-of-path-motion* which serves in inducing a *telicity* value for verb phrases composed with a *til*-PP. This is effected through a combinatory rule for the constellation

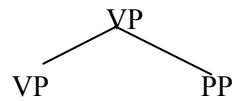

which specifies the head V projection with

SYNSEM|LOCAL|CONT|HOOK|INDEX|TELIC +

in case the PP is marked as in (10). A preposition like *langs* 'along', in contrast, will carry a corresponding specification *along-path-motion*, which fails to induce this effect, leaving the V projection specified as

SYNSEM|LOCAL|CONT|HOOK|INDEX|TELIC bool

A PP like *i to timer* 'for two hours' requires of its sister VP head that it be marked

SYNSEM|LOCAL|CONT|HOOK|INDEX|TELIC -

The type *bool* is compatible with '-', hence a PP with *langs* allows for a combination with *i to timer*:

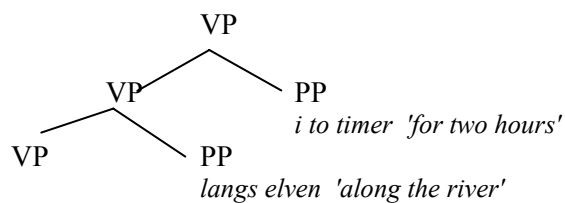

In contrast, a PP like *på to timer* 'in two hours' will combine only with a V projection marked

SYNSEM|LOCAL|CONT|HOOK|INDEX|TELIC +

which means that a PP with *til* will provide a licensing specification for *på to timer*, as in

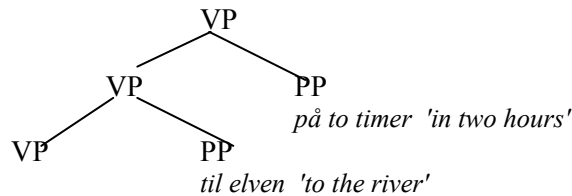

but prevent *i to timer* from combining. In this way, the 'overriding' effect of prepositions like *to* and *til* illustrated in (3) is captured.⁶

The SORT specification associated with a *place*-preposition (or event modifiers, more generally) is in turn compatible with *bool* as telicity value, and thus combine with *i to timer* 'for two hours', in the same way as *langs* and other non-end-point prepositions.

In this sketch, 'telicity' addresses only this factor in so far as it is affected by VP modifiers; in this respect, all verbs are by themselves unmarked, i.e., characterized by *bool*. A distinct feature accommodates inherent aspectual features of verbs, as well as combinatorial aspect induced by the presence vs. absence of objects. As our present concern is with directionals, we will not go into these aspects of verb semantics, nor how they interrelate with features providing specification of whether the verb expresses movement, reflected in the presence of the feature DIRARG.⁷

4.3 Inherent participants and decomposition

We now turn to adverbs with inherent participants, as discussed in section 3. We first consider similarities and contrasts between the end-of-path preposition *til* illustrated in (10), and the adverb *hit* 'to-here', represented in (11) below. Both of these are analyzed as predicating of a *participant*, hence, as seen in (11), also in the MOD value for *hit*, the head verb is specified with regard to its DIRARG.

⁶ It may be noted that this account will license *John ran in two hours*. Although this is not what one would most obviously want, the construction possibly has an interpretation like 'within two hours, John brought it about that he could run', and we therefore regard this case of apparent overgeneration as possibly harmless.

⁷ This is clearly a domain where use of the feature SORT is again relevant. Since the practice in the Matrix is to keep SORT values as atomic (i.e., SORT introduces no features by its own), and verb semantics is well known as requiring some complexity of specification (cf., e.g., Davis 2001, Davis and Koenig 2001, Wechsler 1995), it is an issue for further exploration exactly what features will be necessary in this area.

(11) Feature structure description for the adverb *hit* 'to-here':

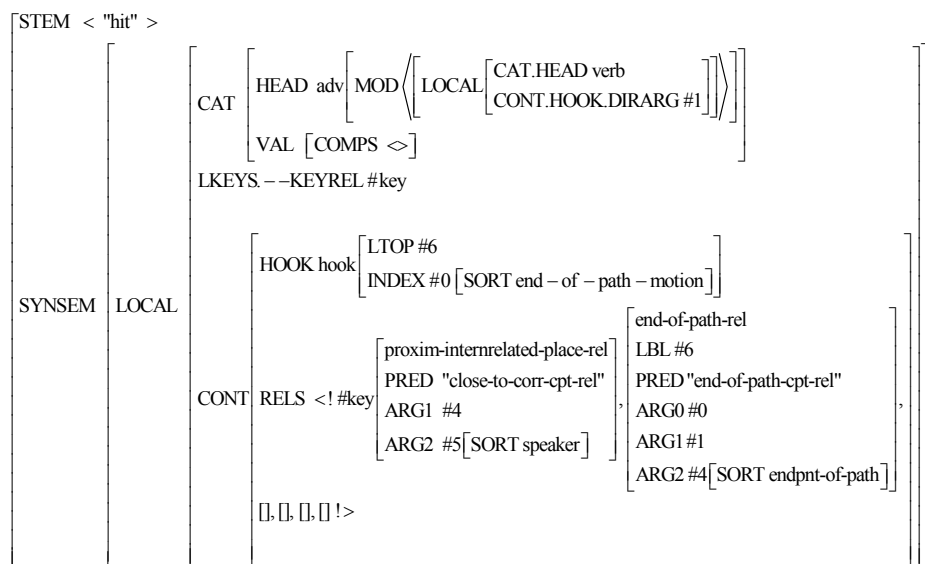

A further parallel is that *hit*, just as *til*, has the value *end-of-path-motion* for the path SYNSEM|LOCAL|CONT|HOOK|INDEX|SORT, whereby its capacity of inducing telicity is represented in exactly the same way as it is for *til*. Still a parallel, announced near the end of section 3, is that both have on their RELS list an EP of type *end-of-path-rel* with an ARG1 and an ARG2, representing the semantic parallelism between directional prepositions and adverbs noted in the discussion.

The interesting difference between (10) and (11) resides in their specifications under RELS: while in (10) there is only one item on this list, in (11) there are (essentially) two. These are binary abstract predicates: the *end-of-path-cpt-rel* relates the Mover (its ARG1) to an endpoint (its ARG2), while the *close-to-corr-cpt-rel* relates the endpoint (its ARG1) to the inherently understood speaker (its ARG2).⁸ The items tagged #4 and #5 are the inherent participants.⁹

⁸ The part *-cpt-* (for 'conceptual') of these labels refers to the circumstance that these predicates are introduced via *decomposition* of lexical items, and thus do not have a spelling matching that of a lexical item.

⁹ As all participants carrying an x-type variable need to be quantified to yield wellformed logical representations (i.e., wellformed MRSs), and there are no overt quantifiers doing this, such quantifiers (with PRED value "pronoun-q-rel"), along with 'restriction' values (with PRED value "zero-pron-context-corr-rel"), have to be introduced into the lexical specification of this item as well; the last four items on the RELS list serve for these purposes. For our present purposes, these four EPs are marked by '[]' in (11), as well as (12) below.

(11) represents a lexical item, and its RELS list is its contribution in the semantic composition of any constituent in which it takes part. We show with (12) an example of an MRS composed by contribution of *hit*:

(12) MRS for the sentence *Gutten løper hit* ('the boy runs to-here'):

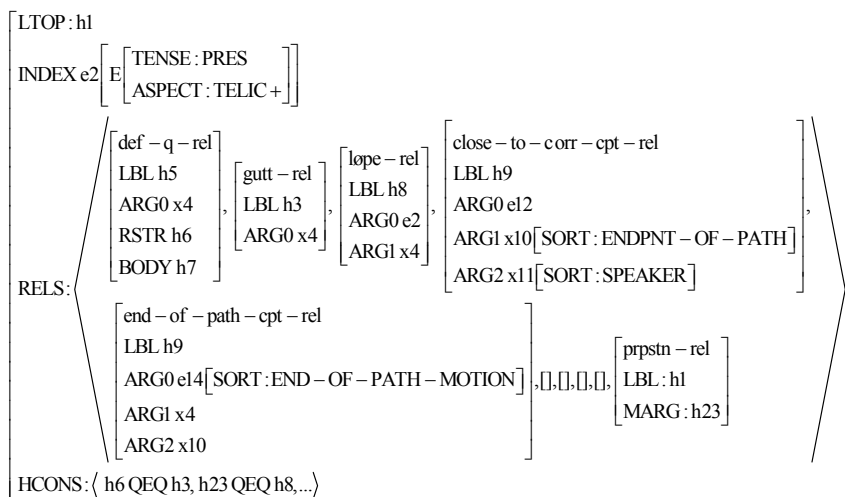

It will be noted that the whole MRS construct has the specification TELIC +, induced by the SORT specification of *end-of-path-rel*, in precisely the same way as indicated above for a preposition like *til*.

Having illustrated the contrast between items with (as with *hit*) and without (as with *til*) inherent participants, but like status as to what they are predicated of (viz., the *Mover*), let us next illustrate the contrast between a predication of a *Mover* (*hit*) and a predication of an event (*her*), along with a contrast between having two and having one inherent participant. At the same time, we illustrate the representation of two distinct words having a common 'semantic feature', here 'closeness to speaker', a property in common between *hit* and *her*:

(13) Feature structure description for the adverb *her* 'here':¹⁰

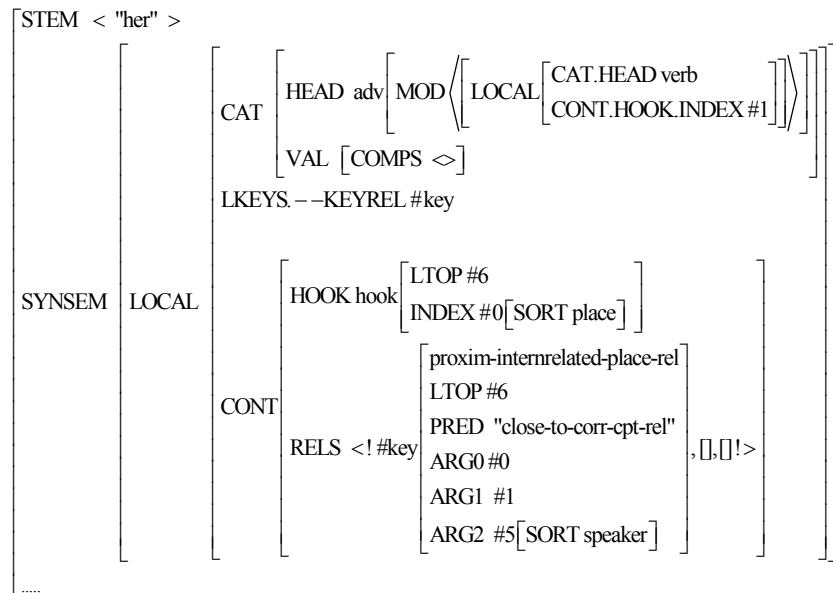

Like the preposition *on* illustrated in (9) above, this is a modifier qualifying the *event* index of the verb. The circumstance that both *her* and *hit* have the PRED value *close-to-corr-rel* in their RELS specification, with ARG2 as 'speaker', accounts for their common feature of referring to a place 'close-to-speaker'. The SORT specification *place* being one which does not induce telicity, *her* is correctly predicted to be combineable with *i to timer* 'for two hours'.

On the basis of the feature structures shown, we briefly indicate how some of the other contrasts illustrated in section 3 are encoded, focussing on endpoint-adverbs, with (4a2, 4b) and (6a) repeated:

- (4a) 2. *dit* 'to-there', as in *Gutten løper dit* ('the boy runs to-there')
boy-DEF run-PRES to-there
- (4b) 1. *opp* '(to) up', as in *Gutten hopper opp* ('the boy jumps up')
boy-DEF jump-PRES to-up
- 2. *ned* '(to) down', as in *Gutten hopp ned* ('the boy jumps down')
boy-DEF jump-PRES to-down
- (6a) 1. *bort* '(to) away', as in *Gutten løper bort* ('the boy runs away')
- 2. *vekk* '(to) away', as in *Gutten løper vekk* ('the boy runs away')
- 3. *ut* '(to) out', as in *Gutten løper ut* ('the boy runs out')
- 4. *inn* '(to) in', as in *Gutten løper inn* ('the boy runs in')

¹⁰ Since this item has only one inherent participant, the abbreviatory place holders on the RELS list are now only two, as opposed to four in (11)/(12).

In relation to the lexical representation (11) of *hit*, and the example (12) of its projection into a sentential MRS, the representation of *dit* will differ only in having *remote-from-corr-cpt-rel* rather than *close-to-corr-cpt-rel* as value at the path `SYNSEM.LOCAL.LKEYS.--KEYREL.PRED`. The representation of *opp* will differ from that of *hit* in having *high-relto-corr-cpt-rel* rather than *close-to-corr-cpt-rel* as PRED-value, and having ARG2| SORT specified as *landmark* rather than *speaker*. The representation of *ned* will differ from that of *opp* only in having *low-relto-corr-cpt-rel* rather than *high-relto-corr-cpt-rel* as PRED -value. The representation of *bort* will differ from that of *opp* only in having *remote-from-corr-cpt-rel*; the representation of *ut* will differ from that of *opp* only in having *outside-relto-corr-cpt-rel* as PRED -value, and the representation of *inn* will differ from that of *opp* only in having *inside-relto-corr-cpt-rel* rather than *high-relto-corr-cpt-rel* as PRED -value.

These specifications are induced through a small hierarchy of *relation* types, of *semsort* types, and of *word* types, where the latter regulate the *relation* types and the specifications in the first EP in the RELS lists (just illustrated above), and the *relation* types induce the *semsort* types. As indicated by this survey, the specifications serve very much like specifications in a componential analysis table, however, being restricted to features of clear grammatical relevance in the languages.¹¹

This subsection has demonstrated a mechanism of semantic componential analysis which preserves important characteristics shared between componentially decomposable and non-decomposable words; examples of the latter are the parameters of participant vs. event modification, and telicity- vs. non-telicity inducing function. We now discuss some of the assumptions made further.

5 Directionals as adjuncts

5.1 The status of iteration

In constructions like

John ran from here to the church

¹¹ Thus, in German semantic parameters of motion such as the telic/atelic distinctions as well as contextual anchoring are, e.g., introduced in the morphological form of particles/ adverbs, as for example (cf. Müller 2002):

(i)	Er	springt	auf /	rauf /	hierauf
	he	jumps	up	on top	on top of this

To demonstrate the application of semantic decomposition for machine translation, we aim in later work at showing an MRS-based set of transfer rules for a fragment of directionals for an MT component between the two languages.

we treat both *from here* and *to the church* as adjuncts, with an assumed structure roughly of the form (14):

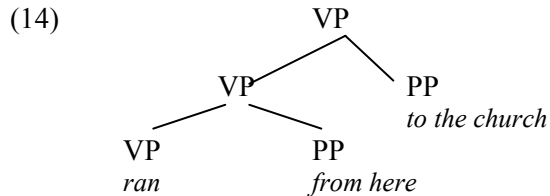

An indication seemingly immediately in favor of such an analysis is the circumstance that such directionals can occur without any upward bound on their number, as in (15):

(15) *John ran from here down via the park along the creek up to the church*

If these directionals were to be analyzed as arguments, it would suggest that standard assumptions about fixedness of valence were to be abandoned, *run* apparently having an indefinite number of possible arguments.

However, we need to contrast constructions like (15) with expansions of constructions like (16a) as in (16b) (from Norwegian - analogous cases would be possible in the other languages): the use of *inn* in (16a) one would treat as an argument, since *sette* 'put' most reasonably should be treated as having two complements in its valence, an object and a locative argument. The multiple occurrences of adverbs and PPs in (16b) will seem to constitute just another instantiation of the pattern in (16a), and hence a case where multiple adverbs/PPs are 'packed' into one argument slot:

(16) a. Jon satte den inn
 John put it in
 b. Jon satte den inn i boksen i hjørnet bort fra sollyset
 Jon put it into box-DEF in corner-DEF away from sunlight-DEF

Seemingly, then, multiplicity of occurrence is not by itself a proof that at a 'top' level, more than one constituent is involved. In (16b), this one constituent in turn may be analyzed as an argument. So, perhaps such an analysis could be applicable also for (15)?

A difference between (16b) and (15) is that in (16b), all the adverbs/PPs are read as specifying one and the same location, whereas in (15), each PP specifies a new stretch of movement. It is to be noted that the 'moving on' sense induced by *run* does not by necessity entail that all adverbs/PPs express different stretches - in the sequence *down via the park* in (15), *down* and *via the park* may well qualify one and the same stretch, and similarly for the directionals in (17):

- (17) Jon gikk opp langs kammen mot Snota
 Jon went up along ridge-DEF towards Snota

Thus, even in the domain of iteration of directionals, one has to recognize the possibility that two or more consecutive directionals co-specify one and the same stretch, or 'leg', analogously to the way the PPs/adverbs in (16b) co-specify one and the same location. For co-specificational clusters like these, it seems that one may well assume a corresponding syntactic clustering - (17), for instance, might receive an analysis like in (18) (although further investigations are warranted to explore what are the possible head-adjunct divisions in such structures - (18) is just one example), and a similar PP cluster would be used in representing the location argument in (16b):

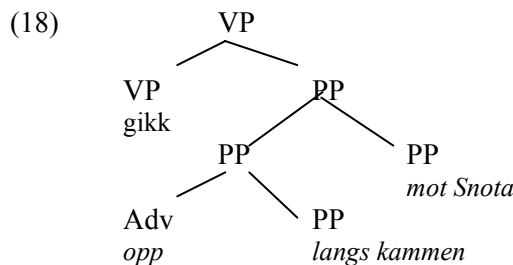

The crucial point that we would like to make is that in the case of iteration of PPs/adverbs tied to verbs like *put*, the clustering analysis is the *only* analysis relevant, whereas for directionals accompanying a verb like *run*, the clustering analysis is only one of the options, and the other is a successive adjunction analysis as illustrated in (15), reflecting a reading where consecutive stretches are being 'consumed'. For this latter construction type, an adjunction analysis seems the more reasonable option. Consequently, for verbs like *run*, whether or not a directional modifier is simple, as in (15), or a cluster as in (18), it either way attaches as an *adjunct*, whereas for a verb like *put*, a locative or directional constituent is necessarily an *argument*.¹²

In the formal analysis of directional adjuncts, a situation like that depicted in (18) will have a semantic representation where the ARG0s of all the PPs or adverbs clustered together have identical value - this represents the circumstance that they are all the *same leg*. (And correspondingly for a structure like in (16b), ARG0 identity will represent identity of location.) For structures like (15), in contrast, the ARG0s will be distinct, displaying the status of the PPs/adverbs as expressing *distinct legs*.

¹² There is in principle a further position construing directionals as arguments which would not entail that a sequence of directionals necessarily shares stretch/leg specification, namely successive application of lexical rules, expanding the verb valence step by step. Such an approach does not seem to make any empirical gains, although might be of relevance in connection with the considerations mentioned in section 5.2.

5.2 The status of DIRARG

The position taken here, to the effect that multiple directionals can reflect multiple adjuncts, was seen to necessitate the introduction of an extra attribute under the verb's HOOK, namely DIRARG, to which each adjunct will refer in tying its ARG1 to the right argument of the verb. It may be noted that if directionals were instead arguments, always abstractly specified in the valence frame of a verb, then this pairing of ARG1 value with the right verb argument would be done inside the valence specifications of each verb, and then the use of a DIRARG attribute would not be required. Let us consider some factors that might count in the evaluation of this feature.

5.2.1 Verbs of 'co-movement'

Verbs like *follow*, *chase*, *pull* and others are commonly interpreted to the effect that the subject argument and the object argument perform the same movement. Would such a situation entail that such verbs have two DIRARGs, and that the ARG1 of each directional is somehow tied to both of those DIRARGs?

We believe that although these verbs clearly need some sort of representation of 'co-movement' in their lexical semantics, this co-movement is not so strict that it warrants a representation of the type alluded to. Typical uses of a verb like *follow*, for instance, tend to fixate on one of the arguments at the time. For instance, in *follow the guests out*, the actual situation is commonly one where only the object - the guests - actually end up outside (the host may stay inside the doorstep). In *I have followed Lenin to where I am today*, analogously, the 'move' described only qualifies the subject. Thus, it seems that verbs of this type have only one DIRARG, but that they alternate in usage as to which argument is tied to ; either way, the general factor of 'co-movement' is always represented, but at a different level than that of DIRARG coindexation. Thus, the verbs of this type do not seem to necessitate a proliferation of DIRARGs.

5.2.2 Controlled adjuncts

Constructions with directionals may be compared to constructions such as those in (19), where the *as*-predicate may seem in principle able to pick any of the argument functions of the head verb as controller (cf. Beermann 1997):

- (19)
- | | | |
|----|---|-----------------|
| a. | They arrived as winners | (subject) |
| b. | They burned her as a witch | (direct object) |
| c. | They gave Jon the responsibility as the captain | (indirect obj.) |

If directionals, as adjuncts, warrant a DIRARG attribute for effecting the control relations, what might constructions like (19) warrant? It may be noted that these control relations are less dependent on specific semantic properties of the verbs involved, and our tentative view is that these control relations should be dealt with at a semantic postprocessing level where coreference resolution more generally may take place. Thus, there is no reason to supplement DIRARG with further features under HOOK for these constructions.

5.3 'Contextual' arguments like 'speaker', 'hearer', 'landmark'

Our semantic representations involving notions like '*speaker*', '*hearer*', '*landmark*', etc, are obviously non-resolved as concerns anaphora and deixis, and in this respect provide only templates for further development of the grammars involved. Compared with designs of context representation like that in Pollard and Sag (1994), it may be noted that where they have 'SPEAKER' as an attribute under CONTEXT, our notion *speaker* emerges as a type used as value of SORT. A motivation for introducing 'speaker' in this way is that in connection with adverbs like *hit* and *her*, what is contextually really involved is a notion of 'most salient point': in a given discourse, this could be resolved as a place which is described as having been reached, whereas its default subtype would be 'speaker'. For this reason, it is reasonable to have the notion 'speaker' construed as a type in a small hierarchy; this of course does not conflict with using the notion also as an attribute.

6 Conclusion

Although the grammars described push their semantic analysis somewhat beyond what is currently instantiated in most MRS based analysis, the formal devices employed are, apart from the one feature DIRARG discussed in the previous section, confined to those contained in the Matrix inventory. This ensures a smooth interface to the other components of a grammar. The semantic analysis itself follows rather standard assumptions from the general literature, in its invocation of a 'mover' as essential in the analysis of directionals, in its treatment of telicity, and in its decomposition of contextually determined locative and directional adverbs. Being still a sentence based grammar, the marking of contextually salient features awaits the incorporation of context anaphoric resolution, but brings the sentential analysis to a point where it can hopefully interact with devices performing such resolution.

References

- Beermann, D. (1997) Syntactic Discontinuity and Predicate Formation. Ph.D. diss., Tilburg University.

- Beermann, D, J.A. Gulla, L. Hellan and A. Prange (2004) 'TrailFinder: an NLP web application for hiking information'. Presented at ScanMatrix meeting, Univ. of Gothenburg, October 2004.
- Bender, E., D. Flickinger and S. Oepen (2002) 'The Grammar Matrix: An open-source starter-kit for the rapid development of cross-linguistically consistent broad-coverage precision grammars.' In: *Proceedings of the Workshop on Grammar Engineering and Evaluation at the 19th International Conference on Computational Linguistics*, 8-14, Taipei, Taiwan.
- Copestake, A. (2002) *Implementing Typed Feature Structure Grammars*. CSLI Publications, Stanford.
- Copestake, A., D. Flickinger, I. Sag and C. Pollard (to appear) 'Minimal Recursion Semantics: An Introduction' (ms, subm. for publication).
- Copestake, A., A. Lascarides and D. Flickinger (2001) 'An Algebra for Semantic Construction in Constraint-based Grammars'. In *Proceedings of the 39th Annual Meeting of the Association for Computational Linguistics (ACL 2001)*, Toulouse.
- Davis, A. 2001. *The Structure of the Hierarchical Lexicon*. CSLI Publications, Stanford.
- Flickinger, D. (2000) 'On building a more efficient grammar by exploiting types', *Natural Language Engineering* 6(1): 15-28, Cambridge University Press.
- Flickinger, D., E. Bender and S. Oepen (2003) 'MRS in the LinGO Grammar Matrix: A Practical User's Guide.' Deep Thought Project Report D3.3.
- Ginzburg, J., and I. Sag (2001) *Interrogative Investigations*. CSLI Publications.
- Gonella, D. and G. Mazzini (2003) 'The Italian Grammar.' Deep Thought Project Report D3.4.
- Hellan, L., and P. Haugereid. 2003.) 'The NorSource Grammar - an exercise in the Matrix Grammar building design'. In: *Proceedings of Workshop on Multilingual Grammar Engineering, ESSLLI 2003*.
- Jackendoff, R. (1990) *Semantic Structure*. MIT Press.
- Müller, St. (2002) *Complex Predicates*. CSLI Publications.
- Pollard, C., and I. Sag (1994) *Head Driven Phrase Structure Grammar*. Chicago University Press, Chicago.
- Sag, I., T. Wasow and E. Bender (2003) *Syntactic Theory. A Formal Introduction*. CSLI Publications, Stanford.
- Siegel, M. and E. M. Bender (2002): 'Efficient Deep Processing of Japanese'. In *Proceedings of the 3rd Workshop on Asian Language Resources and International Standardization. Coling 2002 Post-Conference Work-shop*. Taipei.
- Smith, C. (1991, 1997) *The Parameter of Aspect*. Kluwer.

Underspecification of intersective modifier attachment: Some arguments from German

Berthold Crysmann 

DFKI, Saarland University

Proceedings of the 11th International Conference on
Head-Driven Phrase Structure Grammar

Center for Computational Linguistics, Katholieke Universiteit Leuven

Stefan Müller (Editor)

2004

Stanford, CA: CSLI Publications

pages 378–392

Crysmann, Berthold. 2004. Underspecification of intersective modifier attachment: Some arguments from German. In Stefan Müller (ed.), *Proceedings of the 11th International Conference on Head-Driven Phrase Structure Grammar, Center for Computational Linguistics, Katholieke Universiteit Leuven*, 378–392. Stanford, CA: CSLI Publications. DOI: 10.21248/hpsg.2004.21. 

Abstract

In this paper, I shall discuss the semantic attachment of intersective modifiers in German coherent constructions. I shall show that a purely syntactic solution to the observable attachment ambiguity is undesirable for reasons of processing efficiency and/or massive spurious ambiguity. Instead, I shall follow Egg and Lebeth (1995) and propose an extension to Minimal Recursion Semantics, permitting the expression of underspecified semantic attachment. This rather trivial move, as we shall see, will not only be preferable for processing reasons, but it will also be more in line with the spirit of underspecified semantics, effectively providing a compact representation of purely semantic distinctions, instead of unfolding these distinctions into a rain forest of tree representations and derivations. I will present an implementation of the underspecification approach integrated into the German HPSG developed at DFKI and compare its efficiency to an alternative implementation where semantic attachment is unfolded by means of retrieval rules.

1 Intersective modifiers and word order

It is a well-known property of German that order in the *Mittelfeld* is extremely free: although some restrictions do seem to exist as to the relative order in which a verb's complements can appear, it is by now generally accepted that the linearisation constraints regulating order within the *Mittelfeld* should best be conceived of as soft constraints or performance preferences (Uszkoreit, 1987). The word-order freeness of German is further multiplied by the fact that auxiliaries, modals, control and raising verbs may or must construct coherently (Kiss, 1994, 1995, Müller, 1999, Hinrichs and Nakazawa, 1990), a construction that is modelled by means of Hinrichs/Nakazawa-style argument composition. What is more, inherent and inherited arguments can, again, undergo scrambling, thus, in principle, arguments of the upper and lower verbs may appear in any order.

One of the fundamental empirical tests for the coherent construction — besides scrambling of arguments, of course — builds on the interpretation of modifiers. With a few exceptions, e.g. the marker of sentential negation *nicht* 'not', there does not appear to be any general positional restriction on the distribution of modifiers in the *Mittelfeld*: as a rule of thumb, modifiers can appear just about anywhere between the left and right sentence bracket, demarcated by a complementiser or a finite verb and the sentence-final verb cluster. Independently of position, however, modifiers in the coherent construction often display a systematic ambiguity between high and low attachment.

[†]This work has been carried out as part of the DFKI project QUETAL, funded by the German Federal Ministry for Education and Research (BMBF), and the EU-project DEEPTHOUGHT at the Department for Computational Linguistics, Saarland University. The ideas presented in this paper have benefited a lot from discussion with various people. I would therefore like to thank Ann Copestake, Markus Egg, Dan Flickinger, Stefan Müller, Stephan Oepen and Emily Bender for their comments and suggestions.

- (1) Peter hat es im Labor blitzen sehen
 Peter has it in.the lab flash saw
 ‘Peter saw some flashes/lightning in the lab’ (P”utz, 1982, 340)

As exemplified by the datum above, the PP *im Labor* can modify either the seeing event, or the flashing event: under the first interpretation, Peter is in the lab observing some lightning or flashes somewhere else (possibly outside), whereas under the latter, the flashes are in the lab, with the locus of the observer unspecified.

Although, in (1) the modifier is adjacent to the verb cluster, permitting us to model the two semantic interpretations by means of high or low syntactic attachment, this is not always the case: as illustrated in (2), a flipped auxiliary may intervene (Hinrichs and Nakazawa, 1994, Kathol, 2000, Meurers, 2001), making adjunction to the most deeply embedded cluster element impossible.¹ Still, the modifier displays the same semantic attachment ambiguity as in the example in (1) above.

- (2) weil Peter es im Labor [hat [[blitzen] sehen]]
 because Peter it in.the lab has flash saw
 ‘because Peter saw some flashes/lightning in the lab’

The very same can be observed with scrambling in the Mittelfeld:

- (3) a. weil Peter im Labor es blitzen sah
 because Peter in.the lab it flash saw
 ‘because Peter saw some flashes/lightning in the lab’
 b. weil im Labor Peter es blitzen sah
 because in.the lab Peter it flash saw
 ‘because Peter saw some flashes/lightning in the lab’

Independent of surface position, and, therefore, constituency, modification of upstairs and downstairs verb is equally possible.

Similar evidence against a purely syntactic approach to intersective modifier attachment is provided by Egg and Lebeth (1995):

- (4) Sollen wir im März noch einen Termin machen?
 shall we in March an appointment make
 ‘Should we schedule a meeting in March?’ (Egg and Lebeth, 1995)

The sentence in (4) is three-ways ambiguous: the PP adjunct *im März* ‘in March’ may modify the appointment (*Termin*), the scheduling event (*ausmachen*), or even the modal (*sollen*). Under standard assumptions of phrase structure in

¹For the purposes of this paper I will concentrate foremost on versions of HPSG without word order domains. As far as I can tell, the issues raised within the scope of this paper are by-and-large the same for linearisation approaches and true movement analyses (see below).

the German modal constructions (Kiss, 1994), only attachment to *sollen* should be available. Attachment to the main verb infinitive, however, can only be derived by making otherwise unmotivated assumptions about phrase structure, namely that modals optionally take a VP constituent as their complement.

It should be clear that the data presented thus far constitute a syntax-semantics mismatch: *ceteris paribus*, modification of the downstairs verb obviously conflicts with straightforward rule-by-rule compositionality. Thus, some more elaborated mechanisms are called for to derive the full set of interpretations, independent of constituency in the *Mittelfeld*.

1.1 Storage and Retrieval

One such extension has been proposed in Kiss (1995): to overcome the kind of problem just sketched, he proposes to collect modification targets in a special storage feature from which they can be retrieved whenever a modifier is attached in syntax. Introduction of modification targets onto the storage works in tandem with verb complex formation. Though certainly a viable solution at the time, nowadays, such an approach is not anymore fully attractive, with the Cooper-storage being successfully supplanted by much more concise underspecified descriptions. Furthermore, in a computational setting,² retrieval during parsing can be quite costly, as the exact number of modification targets is locally not always known in bottom-up parsing. Owing to the fact that entire verb clusters can be extracted into the *Vorfeld*, the complexity of the extracted cluster is unknown at the point where the *Mittelfeld* is constructed. Thus, whenever Partial VP Fronting can be hypothesised during parsing, the number of available modification targets to be assumed locally will be equal to the maximum complexity of verbal clusters in German.

- (5) Blitzen sehen hat Peter es im Labor.
flash see has Peter it in.the lab
'Peter saw some flashes/lightning in the lab'

Even if we can put an upper bound on verb cluster complexity — the most complex cluster I found in Meurers (1997) consisted of 5 elements in total —, it should be kept in mind that retrieval of modification targets during parsing will increase by this factor not only the number of head-modifier edges themselves but also the number of chart items that can be transitively derived from these edges. Although the overall frequency of partial VP fronting in German is not that high, local ambiguity is unaffected by this, due to the unbounded nature of the process: even the chart of “harmless” sentences without any PVP fronting is characterised by an incommensurate number of PVP hypotheses.

²As a point of reference I use the fastest processing platform for HPSG grammars currently available, namely PET (Callmeier, 2000) together with the development platform LKB (Copestake, 2001). As for the grammar, I will assume the large-scale grammar of German, developed in the *Verbmobil* context by Müller and Kasper (2000), which has been ported to LKB/PET by Stefan Müller and subsequently enhanced by Berthold Crysmann (Crysmann, 2003, to appear).

Based on these two objections, we can discard the storage-retrieval approach as a suboptimal solution, at least, unless a more efficient and elegant solution can be found.

1.2 Scrambling as movement

Another obvious way to attack the issue is to analyse scrambling as movement, akin to analyses carried out in the generative paradigm. Besides the issue whether or not one should treat essentially local order phenomena on a par with unbounded dependencies, an extraction-based approach will introduce a fair amount of spurious ambiguity into the grammar: unless we can canonicalise the introduction of modifier gaps in a highly restrictive fashion, regulating the relative attachment for every pair of different modifiers, even simple sentences with only one modification target but two intersective modifiers will end up with two syntactically different, yet semantically identical analyses. Worse, the amount of spurious ambiguity thus introduced will be factorial to the number of modifiers present. Finally, in standard bottom-up parsing, the number of modifier gaps to be introduced cannot be known a priori, so we either have to artificially limit the number of scrambled modifiers, or else suffer a termination problem.³ Thus, we can safely discard this latter type of analysis altogether.

2 Modifier interaction

Having established so far that neither a Kiss-style storage and retrieval mechanism nor a movement-based analysis can qualify as optimal solutions to the empirical problem, I will now move on and explore, if and how the treatment of intersective modifier attachment can be likened to that of quantifiers and scopal modifiers, ultimately leading towards a treatment in terms of underspecification.

An important question to be addressed in this context is whether high vs. low attachment of a modifier interacts with the attachment of other modifiers in the sentential domain, or whether different modifiers rather enjoy the same range of attachment possibilities independently of each other.

At least for the interpretation of scopal modifiers, it has repeatedly been claimed (Müller, 1999, Kasper, 1994, Müller, 2004) that scope in the German *Mittelfeld* is determined from left to right. Although I do not doubt that this is the case more often than not, counter-examples to this allegedly hard constraint of German syntax can easily be provided:⁴

³This is at least true in formalisms without lazy evaluation, such as LKB and PET.

⁴The data presented in this section have each been confirmed by 4 native speakers, in addition to my own intuitions. 3 of these subjects are non-linguists, the other does not actively work on German syntax.

- (6) Da muß es schon erhebliche Probleme mit der Ausrüstung gegeben
 there must it severe problems with the equipment given
 haben, da wegen schlechten Wetters ein Reinhold Messner niemals
 have since because.of bad weather a Reinhold Messner never
 aufgabe.
 give-up.would
 ‘There must have been severe problems with the equipment, since someone
 like Reinhold Messner would never give up just because of the bad weather.’

Example (6) contains two scopal modifiers, *niemals* ‘never’ and the *wegen*-PP, a causative operator. Although linear order would suggest interpretation of *niemals* in the scope of the *wegen*-PP, the preferred reading, however, has the relative scope of these two modifiers reversed.

Similar evidence can be found concerning the interaction of intersective modifiers and scopal modifiers.

- (7) Stefan ist wohl deshalb krank geworden, weil er äußerst
 Stefan is presumably therefore ill become because he extremely
 hart wegen der Konferenz in Bremen gearbeitet hat.
 hard because.of the conference in Bremen worked has
 ‘Stefan probably only became ill, because he worked extremely hard be-
 cause of the conference in Bremen.’

As already observed by Kasper (1994, p. 47), embedding of a causal modifier under an intersective manner adverb is ruled out for semantic reasons. Still, a sentence like the one in (7) is completely well-formed, the only available interpretation having the intersective modifier within the scope of the causal modifier.

Thus, we can conclude that the left-to-right scope rule is but a performance preference, however strong.

If we return now to the issue of intersective modifier attachment, we find that here again, the left-to-right rule does not always restrict the range of possible attachments.

- (8) Bei dem Wetter wird ohne Regenmantel ein besorgter Vater seine
 with the weather will without macintosh a caring father his
 Kinder niemals aus dem Haus gehen lassen.
 children never out the house go let
 ‘In this weather, a caring father will never let his children go out without a
 macintosh.’

As illustrated by the example in (8), the PP-modifier *ohne Regenmantel* ‘without a macintosh’ can and, given world knowledge, must attach to the lower verb *ausgehen* ‘go out’, despite the intervention of the scopal temporal modifier *niemals*

‘never’, which scopes over the entire verbal complex, at least under the highly preferred reading. It appears, thus, that the interpretation of an intervening modifier does not interfere with the availability of the downstairs verb as a modification target.

- (9) Der diensthabende Beamte gab zu Protokoll, daß in der
 the policemen who was on duty gave to protocol that in the
 Dachwohnung zum fraglichen Zeitpunkt ein Rentner von der
 loft at.the time in question a retired man from the
 anderen Straßenseite aus die Angeklagte mehrmals auf das Opfer
 opposite side of the road the accused repeatedly on the victim
 einstechen sah.
 stab saw

‘The policemen who was on duty noted that a retired man witnessed from the opposite side of the road that, in the apartment under the roof, at the time in question, the accused stabbed the victim several times.’

This last finding can be replicated with intersective modifiers as well. Here, the PP *von der anderen Straßenseite aus* ‘from the opposite side of the road’ must modify the seeing event⁵ The locative PP *in der Dachwohnung*, however, under the most preferred interpretation, attaches semantically to the downstairs stabbing event.

As we will see below, the observable independence of multiple modifiers with respect to the availability of modification targets will be highly advantageous in the context of an underspecification approach.⁶

3 A proposal

Within current MRS (Copestake et al., 1998, 2001, to appear), the treatment of intersective modifiers essentially assumes that syntactic and semantic structure be homomorphic, as far as attachment is concerned. Thus, at present, this semantic description language does not provide any tools out of the box to address the issues raised in this paper. Essentially, an intersective modifier has its unified with that of the head daughter, whereas its feature is unified with the head daughter’s feature . Both these links are hard-wired. Although this assumption works quite well for highly configurational languages such as English, a treatment along these lines is actually not too well-equipped to deal with non-configurational languages, such as German, where a syntactic solution, as detailed above, will be both inefficient and inelegant.

⁵Unless we want to make the unlikely assumption that the accused has arms as long as Mr Tickle’s.

⁶Conversely, this independence is quite disadvantageous to a storage and retrieval approach, since the number of targets to be considered will not shrink.

If we want to provide an underspecified representation of intersective modifier attachment as well, all we need to do is define a data structure suitable for distributing a modifier's anc and $index$ values over the set of $handle / index$ pairs contributed by the modification targets. These $handle / index$ pairs are best encapsulated as a data structure of their own, which I will call *anc(hor)*, following a proposal of Kiss (in press, 2003) for a semantic treatment of relative clause extraposition. A natural place to represent constraints on the possible attachment of an intersective modifier is the $intersect-mod$ feature, currently hosting *qeq* constraints only.

$$(10) \left[\begin{array}{l} anc \\ \quad handle \\ \quad index \end{array} \right]$$

$$(11) \left[\begin{array}{l} intersect-mod \\ \quad - \quad anc \\ \quad - \quad list(anc) \end{array} \right]$$

With a basic underspecified representation in place, all we have to do in syntax is to define the list of target anchors, and introduce an appropriate constraint into $intersect-mod$, whenever an intersective modifier is syntactically attached.

An implementation of these two steps is quite straightforward. Let us begin with the definition of the list of target anchors: in order to avoid traversal of the $intersect-mod$ list, I will invoke an auxiliary feature $intersect-mod-anc$, which I will assume to be located under $intersect-mod$. The value of this feature is, again, a list of *anc*. Verbs that do not construct coherently, or, that do not take any verbal complements at all, will have a singleton $intersect-mod-anc$ list, where the anc and $index$ features of the only *anc* are unified with the $handle$ and $index$ of the verb itself. Verbs, however, that do construct coherently, will specify an open list, where the first element is again linked to the verb's own $handle$ and $index$. Yet, the rest of the list will be structure-shared with the $intersect-mod$ list of the verbal complement, represented under $intersect-mod$ (see, e.g., Müller, 1999, Kathol, 1999, for motivation of this valence feature).

Now, whenever an intersective modifier gets syntactically attached, we simply add a new *intersect-mod* constraint to the $intersect-mod$ list, unifying its $handle$ and $index$ with the $handle$ and $index$ of the modifier's head. The $intersect-mod-anc$ feature of this constraint will just be structure-shared with the $intersect-mod-anc$ feature of the head-daughter's $intersect-mod$.

As to scopal modifiers, nothing fancy has to be done here: all one needs to do is to have the scopal modifiers $intersect-mod$ outscope the lowest handle in the verb cluster. As a consequence, scopal modifiers will be able to assume any intermediate scope. The attentive reader will have noticed that the solution proposed here implicitly assumes independent phrase structure schemata for intersective and scopal modification. However, this is not really new: as argued by Copestake et al. (to appear), such a move is independently required to ensure a sound treatment of Kasper's problem.

Comparing the approach advanced here with the alternative solutions refuted above, we find that it is highly similar to a storage approach, with the retrieval step delayed to post-syntactic semantic resolution. Under a processing perspective, however, such a move is highly advantageous: first, purely semantic distinctions are effectively encapsulated in the λ -value, rather than expanded into different tree representations or derivations. Furthermore, as we have seen above, proper attachment can often not be resolved on the basis of sortal restrictions. Rather, it is world or discourse knowledge that decides on the most likely attachment. Second, unfolding the set of possible attachment as part of MRS resolution will be much more efficient, as the issue of local ambiguity and the adverse effects on the search space encountered in parsing are simply non-issues: the size of the resulting parse forest and the associated MRS substructures are actually tiny in comparison to the chart that needs to be explored to deliver them.

The approach to underspecified intersective modifier attachment suggested here bears the further potential of reducing processing cost in the context of relative clause extraposition. As detailed in Crysmann (to appear), a considerable amount of the additional cost required by my implementation of a Kiss-style approach to German relative clause extraposition is spent on the retrieval of suitable anchors during parsing: with an upper limit of the 5 most recent anchors introduced, the relative cost of integrating this construction is reflected in an increase by of executed chart items by around 12.7% on the Babel test suite.⁷ With the kind of underspecification advocated here, retrieval can, again, be postponed to a semantic post-processing step, avoiding retrieval costs and ensuring termination without having to impose arbitrary limits. It is of note, in this context, that the data structure suggested here for the expression of underspecified modifier attachment, i.e. λ -pairs, also plays a crucial role under a semantic approach to relative clause extraposition, like the one suggested by Kiss (in press, 2003).

4 Evaluation

In the preceding sections, we have seen that the semantic attachment of intersective modifiers cannot be derived on the basis of surface phrase structure alone. We have discussed three alternative approaches — movement, storage and retrieval, and underspecification — and concluded that among these three, the movement-based approach should be rejected a priori, since it will lead to massive spurious ambiguity, as well as suffer from termination problems on systems without lazy evaluation, such as LKB or PET. This leaves us with only two options: a Kiss-style storage and retrieval approach, and underspecified attachment.

In order to substantiate the expected performance gains of the underspecification approach over a storage and retrieval mechanism (cf. Egg and Lebeth, 1995),

⁷It should be kept in mind that the impact of retrieval rules on relative clause extraposition is of a must lesser degree than what we can expect for ordinary modifiers, owing to the fact that these rules are only applied once a rather large sentential constituent has already been built.

LKB/PET implementations of both variants have been provided and subsequently evaluated. As evaluation corpora, I have chosen the manually constructed Babel test-suite (Müller, 2004; 758 test items), as well as a subset of the Verbmobil spoken language corpus (VM CD-15; 2233 test items).

The underspecification variant is compared to a baseline where semantic attachment is isomorphic to syntactic attachment, enabling us to estimate the minimal cost associated with a sound treatment of intersective modifier attachment.

All test runs have been performed on an Intel Pentium 4 M with 1 GB RAM, running Linux 2.4.26. The version of PET used for the tests dates from July 2003. Test results have been collected and evaluated with [incr tsdb()] (Oepen and Flickinger, 1998).

4.1 Baseline vs. Underspecification

The implementation of underspecified modifier attachment was derived directly from a baseline implementation where modifiers could only semantically attach to the label and index of their syntactic sister (see Müller and Kasper (2000), Müller (2004), Crysmann (2003, to appear) for further details on the German HPSG developed at DFKI). Most obviously, the grammar was extended with a mechanism to collect lists of target anchors during verb cluster construction. Furthermore, the distinction between intersective and scopal modification, which was hitherto performed at the level of lexical types only, is now replicated at the level of phrase structure schemata. Recall that such a move is independently required to provide a solution to Kasper’s problem along the lines proposed in Copestake et al. (to appear). While such a move is virtually cost-neutral for local head-adjunct structures — selection of intersective vs. scopal head-adjunct schemata is entirely determined by the lexical type of the modifier —, this is not the case with adjunct extraction: since the type of modifier is not known locally, we expect an increase in local ambiguity during parsing.⁸ Finally, in order to control for spurious ambiguity, syntactic attachment to downstairs verbs in the cluster is blocked. Thus, even those attachment ambiguities that could in principle be resolved at the level of bare phrase structure are now taken care of by target anchor percolation and underspecified semantic attachment.

The results for these two grammars are given in tables 1 and 2. As depicted in table 1, both grammars have roughly the same coverage on the two corpora used for evaluation. While lexical ambiguity of the grammars is the same, syntactic ambiguity is slightly reduced under the underspecification approach. This slight reduction can be attributed to the elimination of syntactic attachment ambiguities for cluster-adjacent adjuncts.

With respect to performance⁹, we record mild efficiency gains on both corpora.

⁸The additional cost associated with adjunct extraction could in principle be eliminated by moving the semantic effect of adjunction from the gap site to the filler site. Due to time constraints, however, this solution was not explored in the grammars presented here.

⁹Throughout this paper, tasks represent the average number of executed tasks per item, time is

Test suite			Baseline		Underspecification	
	words	lex amb	cov	amb	cov	amb
VM 15	5.18	2.96	84.7	9.92	84.8	9.36
Babel	6.76	2.99	82.9	3.68	82.9	3.67

Table 1: Baseline vs. Underspecification: Coverage & Ambiguity

Test suite	items	Baseline			Underspecification			Factor		
		tasks	time	space	tasks	time	space	tasks	time	space
VM 15	2233	12896	.83	24172	13650	.76	22969	1.058	.906	.95
Babel	758	4117	.21	6731	3639	.18	5755	.884	.849	.855

Table 2: Baseline vs. Underspecification: Performance (including non-exhaustive parses)

Thus, we can conclude that the underspecified approach provides an efficient way to arrive at a complete representation of the attachment potential of intersective modifiers.

4.2 Underspecification vs. Storage & Retrieval

In a second implementation step, I have derived a third version of the grammar, where semantic attachment is fully resolved in syntax. Since percolation of modification targets is unaffected by the way that a modifier gets semantically bound to a target anchor, I have derived this version from the underspecification approach.

The only changes that needed to be performed involve the unfolding of syntactically underspecified attachment into distinct intersective head-adjunct rules: thus, instead of a single head-adjunct rule that simply inserts an appropriate modification constraints into the MRS, representing the distribution of the modifiers anchor over the list of target anchors, we now have to enumerate, by means of distinct syntactic rules, the range of possible semantic attachments. In order to ensure a fair comparison, I have limited access to percolated anchors to the first 3 target anchors. This number should correspond quite well to the maximum complexity of verb clusters observed in corpora, which is 4 (Müller, p.c.), considering that verb clusters of this size will most probably include tense or passive auxiliaries, which I assume to share their event variable with that of the main verb they combine with. In sum, the transition from a syntactically underspecified analysis of intersective modifier attachment to a storage and retrieval approach involves tripling the number of head-initial and head-final intersective head-adjunct rules, as well as that of intersective adjunct extraction rules. As a result, local ambiguity during parsing will increase by this figure, in the worst case.

The results of the comparison between the underspecification and storage/retrieval approaches are summarised in tables 3–5.

average parse time per item in seconds, and space indicates the average space consumption per item in kB.

As shown in table 3, overall coverage decreases with the storage and retrieval approach. This result is directly related to the decrease in parsing efficiency to be described below, reflecting the exhaustion of available resources (70,000 passive edges) before a result could be delivered.

Test suite			Underspecification		Storage/Retrieval	
	words	lex amb	cov	amb	cov	amb
VM 15	5.18	2.96	84.8	9.37	83.6	11.48
Babel	6.76	2.99	82.9	3.68	82.5	3.48

Table 3: Underspecification vs. Storage & Retrieval: Coverage & Ambiguity

Test suite	items	Underspecification			Storage/Retrieval			Factor		
		tasks	time	space	tasks	time	space	tasks	time	space
VM 15	2233	13650	.76	22969	24892	1.24	32324	1.824	1.644	1.407
Babel	758	3639	.18	5755	5942	.27	7870	1.633	1.535	1.368

Table 4: Underspecification vs. Storage & Retrieval: Performance (including non-exhaustive parses)

With respect to performance, a direct comparison on all test items reveals that the syntactic retrieval of anchors is quite costly, leading to an increase by more than 50% in parse time. However, as we have already observed above, the difference in coverage the two grammars display on Verbmobil data is due to the fact that the less efficient storage and retrieval approach reaches the upper limit of 70,000 passive edges much more often than the grammar implementing the underspecification approach. It appears thus, that the less efficient grammar might benefit from a ceiling effect here, since, on items where the available resources are exhausted, this grammar cannot possibly get worse than the time it takes to build up 70,000 passive edges.

In order to get a more accurate picture of the relative performance of the two grammars, I therefore provide additional performance data, derived from those test items where both grammars had been able to explore the entire parse space within the given limit.

Test suite	items	Underspecification			Storage/Retrieval			Factor		
		tasks	time	space	tasks	time	space	tasks	time	space
VM 15	2070	3330	.17	5456	9277	.43	12069	2.786	2.594	2.212
Babel	758	2981	.14	4680	4791	.22	6203	1.607	1.508	1.325

Table 5: Underspecification vs. Storage & Retrieval: Performance (intersection of exhaustively parsed items)

The intersection of sentences exhaustively parsed by both grammars provides a more reliable comparison, showing that, on Verbmobil data of moderate complexity, the underspecification outperforms the storage and retrieval approach to intersective modifier attachment by a factor of 2.6.

5 Conclusion

In this paper I have argued for an extension to Minimal Recursion Semantics (MRS; Copestake et al., 1998, 2001, to appear) permitting the expression of underspecified intersective modifier attachment similar to the proposal of Egg and Lebeth (1995). I have argued on the basis of German modifiers in the coherent construction that a complete, compact, and efficiently processable solution to the attachment ambiguity problem necessitates a treatment in underspecified terms. Furthermore, we have seen that the attachment potential of each individual modifier in the sentential domain is independent of the other modifiers in this domain. This particular finding has paved the way for a straightforward analysis in terms of MRS, enhanced by a new type of handle constraint, recording a modifiers anchor, together with the target anchors it can distribute over. This proposal, in contrast to the alternative syntactic solutions discussed in the text, puts the treatment of the issue much more in line with the spirit of underspecified semantics, namely to provide a compact representation of entirely semantic distinctions.

The proposal has been implemented as part of the German HPSG developed at DFKI, and systematically compared to an alternative approach, involving syntactically resolved attachment to percolated anchors. As detailed by the evaluation results presented in this paper, the underspecification approach outperforms the alternative syntactic solution by a factor between 1.5 and 2.6.

I have further argued that this particular proposal can also be put to use in the context of German relative clause extraposition. Furthermore, I conjecture that such an approach can be fruitfully applied to any other language featuring complex predicate formation of the argument composition type.

References

- Callmeier, Ulrich. 2000. PET — A Platform for Experimentation with Efficient HPSG Processing Techniques. *Journal of Natural Language Engineering* 6(1), 99–108.
- Copestake, Ann. 2001. *Implementing Typed Feature Structure Grammars*. Stanford: CSLI Publications.
- Copestake, Ann, Flickinger, Dan, Pollard, Carl and Sag, Ivan. to appear. Minimal Recursion Semantics: an introduction. *L & C*.
- Copestake, Ann, Flickinger, Dan and Sag, Ivan. 1998. Minimal Recursion Semantics. An Introduction, proceedings of ESSLLI 10, Saarbrücken.
- Copestake, Ann, Lascarides, Alex and Flickinger, Dan. 2001. An Algebra for Semantic Construction in Constraint-based Grammars. In *Proceedings of the 39th Annual Meeting of the Association for Computational Linguistics, Toulouse, France*.

- Crysmann, Berthold. 2003. On the Efficient Implementation of German Verb Placement in HPSG. In *Proceedings of RANLP 2003*, pages 112–116, Borovets, Bulgaria.
- Crysmann, Berthold. to appear. Relative Clause Extraposition in German: An Efficient and Portable Implementation. *Research on Language and Computation*.
- Egg, Markus and Lebeth, Kai. 1995. Semantic Underspecification and Modifier Attachment Ambiguities. In J. Kilbury and R. Wiese (eds.), *Integrative Ansätze in der Computerlinguistik (DGfS/CL '95)*, Düsseldorf, Seminar für Allgemeine Sprachwissenschaft, pages 19–24.
- Hinrichs, E. and Nakazawa, T. 1990. Subcategorization and VP Structure in German. In Hughes, Shaun and Salmons (eds.), *Proceedings of the Third Symposium on Germanic Linguistics*, Amsterdam: Benjamins.
- Hinrichs, Erhard and Nakazawa, Tsuneko. 1994. Linearizing AUXs in German Verbal Complexes. In John Nerbonne, Klaus Netter and Carl Pollard (eds.), *German in Head-Driven Phrase Structure Grammar*, Lecture Notes, No. 46, pages 11–37, Stanford University: CSLI Publications.
- Kasper, Robert T. 1994. Adjuncts in the Mittelfeld. In John Nerbonne, Klaus Netter and Carl Pollard (eds.), *German in Head-Driven Phrase Structure Grammar*, Lecture Notes, No. 46, pages 39–69, Stanford University: CSLI Publications.
- Kathol, Andreas. 1999. Linearization versus Phrase Structure in German Coordinate Constructions. *Cognitive Linguistics* pages 303–342.
- Kathol, Andreas. 2000. *Linear Syntax*. Oxford: Oxford University Press.
- Kiss, Tibor. 1994. Obligatory Coherence: The Structure of German Modal Verb Constructions. In John Nerbonne, Klaus Netter and Carl Pollard (eds.), *German in Head-Driven Phrase Structure Grammar*, Lecture Notes, No. 46, pages 71–107, Stanford University: CSLI Publications.
- Kiss, Tibor. 1995. *Infinite Komplementation. Neue Studien zum deutschen Verbum infinitum*. Linguistische Arbeiten, Tübingen: Niemeyer.
- Kiss, Tibor. 2003. Phrasal Typology and the Interaction of Topicalization, Wh-movement, and Extraposition. In Jong-Bok Kim and Stephen Wechsler (eds.), *Proceedings of the 9th International Conference on Head-driven Phrase Structure Grammar, Kyung Hee University, Seoul, 5–7 August, 2002*, Stanford: CSLI Publications.
- Kiss, Tibor. in press. Semantic Constraints on Relative Clause Extraposition. *Natural Language and Linguistic Theory* forthcoming.

- Meurers, Detmar. 2001. To flip or not to flip: On the nature of irregularities in the German verbal complex. In *Proceedings of the 8th International Conference on Head-Driven Phrase Structure Grammar*, CSLI Online Proceedings, pages 235–246, Stanford: CSLI Publications.
- Meurers, Walt Detmar. 1997. Statusreaktion und Wortstellung in kohärenten Infinitkonstruktionen des Deutschen. In Erhard Hinrichs, Walt Detmar Meurers, Frank Richter, Manfred Sailer and Heike Winhart (eds.), *Ein HPSG-Fragment des Deutschen. Teil 1: Theorie*, volume 95 of *Arbeitspapiere des SFB 340*, pages 189–248.
- Müller, Stefan. 1999. *Deutsche Syntax — deklarativ*. Linguistische Arbeiten, Tübingen: Niemeyer.
- Müller, Stefan. 2004. Continuous or Discontinuous Constituents? A Comparison between Syntactic Analyses for Constituent Order and Their Processing Systems. *Research on Language and Computation* 2(2), 209–257.
- Müller, Stefan and Kasper, Walter. 2000. HPSG Analysis of German. In Wolfgang Wahlster (ed.), *Verbmobil: Foundations of Speech-to-Speech Translation*, pages 238–253, Berlin: Springer.
- Oepen, Stephan and Flickinger, Dan. 1998. Towards Systematic Grammar Profiling. Test Suite Technology Ten Years After. *Journal of Computer Speech and Language* 12, 411–436.
- Pütz, Herbert. 1982. Objektsprädikate. In Werner Abraham (ed.), *Satzglieder im Deutschen – Vorschläge zur syntaktischen, semantischen und pragmatischen Fundierung*, pages 331–367, Tübingen: Gunter Narr Verlag.
- Uszkoreit, Hans. 1987. *Word Order and Constituent Structure in German*. Stanford: CSLI Publications.

Constraint-based RMRS construction from shallow grammars

Anette Frank 

DFKI Saarbrücken

Kathrin Spreyer

DFKI Saarbrücken

Witold Drożdżyński

DFKI Saarbrücken

Hans-Ulrich Krieger

DFKI Saarbrücken

Ulrich Schäfer 

DFKI Saarbrücken

Proceedings of the 11th International Conference on
Head-Driven Phrase Structure Grammar

Center for Computational Linguistics, Katholieke Universiteit Leuven

Stefan Müller (Editor)

2004

Stanford, CA: CSLI Publications

pages 393–413

Frank, Anette, Kathrin Spreyer, Witold Drożdżyński, Hans-Ulrich Krieger & Ulrich Schäfer. 2004. Constraint-based RMRS construction from shallow grammars. In Stefan Müller (ed.), *Proceedings of the 11th International Conference on Head-Driven Phrase Structure Grammar*, Center for Computational Linguistics, Katholieke Universiteit Leuven, 393–413. Stanford, CA: CSLI Publications. DOI: 10.21248/hpsg.2004.22. 

Constraint-Based RMRS Construction from Shallow Grammars

Abstract

We present a constraint-based syntax-semantics interface for the construction of RMRS (Robust Minimal Recursion Semantics) representations from shallow grammars. The architecture is designed to allow modular interfaces to existing shallow grammars of various depth—ranging from chunk grammars to context-free stochastic grammars. We define modular semantics construction principles in a typed feature structure formalism that allow flexible adaptation to alternative grammars and different languages.

1 Introduction

Semantic formalisms such as UDRT (Reyle, 1993), CLLS (Egg et al., 2001), or MRS (Copestake et al., 2003) provide elegant solutions for the treatment of semantic ambiguities in terms of underspecification—most prominently scope. In recent work, Copestake (2003) has investigated a novel aspect of underspecification in the design of semantic formalisms, which is concerned with the representation of *partial* semantic information, as it might be obtained from shallow, i.e., incomplete syntactic analysis. The main rationale for this type of underspecification is to ensure monotonicity, and thus upwards compatibility of the output of shallow parsing with semantic representations obtained from full syntactic parsing. Thus, Copestake’s design of RMRS—Robust Minimal Recursion Semantics—provides an important contribution to a novel line of research towards integration of shallow and deep NLP. While previous accounts (Daum et al., 2003; Frank et al., 2003a) focus on shallow-deep integration at the syntactic level, Copestake aims at integration of shallow and deep NLP at the level of semantics.

In this paper we review the RMRS formalism designed by Copestake (2003) and present an architecture for a principle-based syntax-semantics interface for RMRS construction from shallow grammars. We argue for a unification-based approach to RMRS construction, to account for (underspecified) argument binding in languages with morphological as opposed to structural argument identification. We propose a reparsing architecture for RMRS construction that is especially designed to support flexible adaptation to different types of shallow to intermediate-level syntactic grammars that may serve as a basis for RMRS construction. We define modular semantics construction principles in a typed feature structure (TFS) formalism (Carpenter, 1992), which favours the portability to new grammars and languages. A challenge for principle-based semantics construction from shallow

[†]The research reported here was conducted in the project QUETAL, funded by the German Ministry for Education and Research, BMBF, under grant no. 01 IW C02. Thanks go to Ann Copestake and Dan Flickinger for discussion of our work, and to the audience of the HPSG Workshop on Semantics in Grammar Engineering, for interesting comments and questions.

grammars is the flat and sometimes non-compositional nature of the structures they typically produce. We propose RMRS semantics construction principles that can be applied to flat syntactic structures with various degrees of partiality.

The paper is structured as follows. Section 2 introduces the RMRS formalism. Section 3 gives an overview of the architecture we propose for RMRS construction from shallow grammars. We argue for a modular, constraint-based semantics construction module in a reparsing architecture, which we realise in the unification-based finite-state processing platform SProUT (Becker et al., 2002; Drozdzyński et al., 2004). In Section 4, we present the principles we define for morphological disambiguation and semantics construction from shallow grammars. Section 5 concludes and compares our work to alternative approaches.

2 RMRS—A Formalism for Partial Semantic Representation

Copestake (2003) presents a formalism for partial semantic representation that is derived from Minimal Recursion Semantics (MRS) (Copestake et al., 2003). Robust Minimal Recursion Semantics is designed to support novel forms of integrated shallow and deep NLP, by accommodating semantic representations produced by NLP components of various degrees of partiality and depth of analysis—ranging from PoS taggers and NE recognisers over chunk and (non-)lexicalised context-free grammars to deep grammars like HPSG with MRS output structures.

The advantages of a variable-depth semantic analysis are most evident for applications with conflicting requirements of robustness and accuracy. Given a range of NLP components of different depths of analysis that deliver compatible semantic representations, we can apply flexible integration methods: apply voting techniques, or combine partial results from shallow and deep systems (Copestake, 2003).

To allow intersection and monotonic enrichment of the output representations from shallow systems on one extreme of the scale with complete representations of deep analysis on the other, the missing specifications of the weakest system must be factored out from the most comprehensive deep representations. In the RMRS formalism, this concerns the following main aspects of semantic information:

Argument encoding. A ‘Parsons-style’ notation accommodates for partiality of shallow systems wrt. argument identification. Instead of predicates with fixed arity, e.g., $l4:on(e',e,y)$, predicates and arguments are represented as independent elementary predications: $on(l4,e')$, $ARG1(l4,e)$, $ARG2(l4,y)$. This accounts for the uncertainty of argument identification in shallow grammars. Underspecification with respect to the type of argument is modeled in terms of a hierarchy over disjunctive argument types: $ARG1 \sqsubset ARG12$, $ARG2 \sqsubset ARG12$, $ARG12 \sqsubset \dots \sqsubset ARGn$.

Variable naming and equalities. Constraints for equality of variables in elementary predications are to be added incrementally, to accommodate for knowledge-poor systems like PoS taggers, where the identity of referential variables of, e.g., adjectives and nouns in potential NPs cannot be established, or else chunkers, where the binding of arguments to predicates is only partially established.

An example. The following example of corresponding MRS (1.a) and RMRS (1.b) representations illustrates these differences (cf. Copestake, 2003).

(1) *Every fat cat sat on a mat*

a. MRS representation:

10:every(x,h1,h2), 11:fat(x), 12:cat1(x), 13:CONJ, 14:sit1(e_{spast},x),
114:on2(e',e,y), 19:CONJ, 15:some(y,h6,h7), 16:table1(y), qeq(h1,l3),
qeq(h6,l6), in-g(13,l1), in-g(13,l2), in-g(19,l4), in-g(19,l14)

b. RMRS representation:

10:every(x0), RSTR(10,h1), BODY(10,h2), 11:fat(x1), 12:cat1(x2),
13:CONJ, 14:sit1($e3_{spast}$), ARG1(14,x2), 114:on2(e4), ARG1(114,e3),
ARG2(114,x5), 19:CONJ, 15:some(x5), RSTR(15,h6), BODY(15,h7),
16:table1(x6), qeq(h1,l1), qeq(h6,l6), in-g(13,l1), in-g(13,l2), in-g(19,l4),
in-g(19,l14), $x0 = x1$, $x1 = x2$, $x5 = x6$

3 An Architecture for RMRS Construction from Shallow Grammars

We aim at a modular syntax-semantics interface for RMRS construction that can be adapted to a wide range of *existing* shallow grammars, such as off-the-shelf chunk parsers or probabilistic (non-)lexicalised PCFGs. Moreover, we aim at the construction of underspecified, but *maximally constrained* (i.e., *resolved*) RMRS representations from shallow grammars.

A unification-based account. Chunk parsers and PCFG parsers for sentential structure do in general not provide functional information that can be used for argument identification. While in languages like English argument identification is to a large extent structurally determined, in other languages arguments are (partially) identified by case marking. In case-marking languages, morphological agreement constraints can yield a high degree of completely disambiguated constituents, as shown by Hinrichs and Trushkina (2002) for German. That is, by morphological disambiguation we can obtain maximally constrained identification of arguments from shallow analyses (see also Müller, 2004). We therefore propose a *unification-based approach* for RMRS construction, where agreement constraints can perform morphological disambiguation, and thus partial (i.e., underspecified) argument identification in case-marking languages.

In addition, by interfacing shallow analysis with morphological processing, we can infer important semantic features for referential and event variables, such as PNG and TENSE information. Thus, morphological processing can also be beneficial for languages with structural argument identification.

A reparsing architecture. In order to realise a *modular* interface to existing parsers, we follow a reparsing approach: For semantics construction, we extract constituency information from the output structure of a shallow parser, and deterministically reparse the original input string, while applying RMRS construction principles to the recomposed syntactic structures.

The advantages of a reparsing architecture—as opposed to a grammar with integrated syntactic and semantic rules—are that modular semantics construction rules can be adapted to the output structures of alternative existing parsers, including statistical parsers. Similarly, modular semantics construction rules can be ported to other languages, and applied to the output structures of existing chunkers or parsers for such languages.

Constraint-based RMRS construction—using cascaded SProUT. We define constraint-based principles for RMRS construction in a typed feature structure formalism. These semantics construction principles are applied to the (reparsed) syntactic structures provided by shallow parsing. In the reparsing step the constraints are resolved, to yield maximally specified RMRS representations.

The RMRS construction principles are defined and processed in the SProUT processing platform (Becker et al., 2002; Krieger et al., 2004). The SProUT system combines finite-state technology with unification-based processing. It allows the definition of finite-state transduction rules that apply to (sequences of) typed feature structures (TFSs), as opposed to atomic symbols. The left-hand side of a transduction rule specifies a regular expression over TFSs as a (longest-match) recognition pattern; the right-hand side specifies the output in terms of a typed feature structure. Regular expression operators are ? (optionality), *, + (Kleene star and plus), and {n,m} (constrained iteration). Figure 1 displays a SProUT rule for the recognition of an NP consisting of an optional determiner, any number of adjectives and a noun. Coreferences (#) enforce unification of the referenced feature values. In the example, this enforces agreement of determiner, adjective and noun.

```
np :> morph & [POS art, INFL [CASE #case, NUM #num, GEND #gend]]?
      morph & [POS adj, INFL [CASE #case, NUM #num, GEND #gend]]*
      morph & [POS noun, INFL [CASE #case, NUM #num, GEND #gend]]
-> phrase & [CAT np, AGR [CASE #case, NUM #num, GEND #gend]].
```

Figure 1: Example of a SProUT rule (cf. Krieger et al., 2004).

The rewrite rules are interfaced with a hierarchy of typed feature structures. In Figure 1, the rule is constrained to apply to feature structures of type *morph*; the output structure is defined to be of type *phrase*. The corresponding hierarchy of typed feature structures is specified separately from the rules.

The SProUT system offers a number of special features that proved extremely useful for our purposes.

Most importantly, the system has been extended to cascaded processing, such that the output of a set of rule applications (viz., TFSs) can provide the input to another set of rewrite rules, again on TFSs. This allows us to realise a cascade of grammars for lexical and phrasal RMRS construction, which we describe in more detail in Section 4.

Since SProUT operates on typed feature structures, we can define a hierarchy of types that facilitates the concise definition of semantics construction rules.

In SProUT, several distinct rules can simultaneously apply to the same sequence of input items, as long as the same (maximal) sequence of structures is matched. The output structures defined by the individual rules can then be unified, by special interpreter settings. This allows us to state modular RMRS construction principles with general application conditions that interact to yield complete RMRS structures.

The system offers a mechanism for rule prioritisation that implements *defaults*: rules can be (strictly)¹ ordered according to their priority, such that a rule with lower priority can only apply in case no rule with higher priority could be applied to the same input structure.

Finally, SProUT permits the definition of so-called *functional operators* to impose additional constraints for the application of a rule. Functional operators may extend the formal power of typed unification, and will be used for the implementation of constraining equations in argument identification rules (cf. Section 4.3).

Cascaded reparsing with SProUT. For cascaded reparsing, SProUT first performs morphological lookup on the original input string, which yields as output a list of TFSs of type *morph*. The morphological information is organised in a type hierarchy with disjunctive subtypes to underspecify ambiguities of inflectional features, e.g., case (see Krieger and Xu, 2003, and below).

The output sequence of morphological TFSs is input to the next cascade levels that perform morphological disambiguation and phrase composition.

For cascaded reparsing, or phrase composition according to the output structure of a shallow (context-free) parser, we enrich the input TFSs with constituency information that we extract from the parse tree for the corresponding input span: for each node we extract a uniquely referring node identifier (ID), together with the identifier (M-ID) and category (M-CAT) of its mother node. This implicitly encodes the necessary information about phrasal constituency that can be used to guide phrase composition and concurrent semantics construction in reparsing with SProUT. As unique node identifiers, we use word/phrase span information, as indicated in Figure 2.²

¹Extensions for specification of *partial* ordering of rules are under way.

²Alternatively, one could use character position spans for node identification.

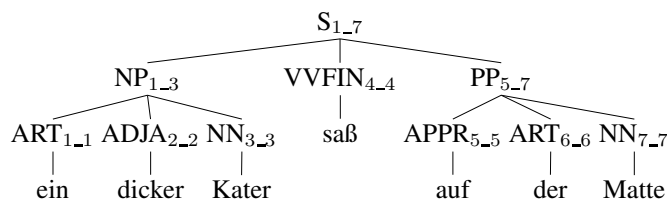

Figure 2: Indexed syntactic tree: *Ein dicker Kater saß auf der Matte* – A fat cat sat on the mat.

```

phrase :-> synsem & [NODE [M-ID #mid, M-CAT #mcat]]+
      -> phrase & [NODE [ID #mid], [M-SYN [CAT #mcat]]].
  
```

Figure 3: Reparsing rule.

A general reparsing rule, displayed in Figure 3, is applied to the enriched input sequence of TFSs for lexical or phrasal nodes and produces as output a TFS for the implicitly defined mother node. The rule specifies that for all nodes in the matched input sequence,³ their mother node identifier and category features (M-ID, M-CAT) must be identical, and defines the output (mother) node’s local identifier and category feature (ID, CAT) by use of co-references (#mid, #mcat). Since the system obeys a longest-match strategy, the regular expression is constrained to apply to the same constituents as in the original parse tree.

Cascaded reparsing first applies to the sequences of leaf nodes that are provided by morphological processing. The output node sequence is enriched with the phrase-building information from the original parse tree, and is input to the phrase building and semantics construction rules. For phrase composition we define a cyclic cascade, where the output of a cascade is fed in as input to the same rules. The cycle terminates when no more phrase building rules could be applied to the input, i.e., the root category has been derived. This establishes a kind of fixpoint construction.

Morpho-syntactic disambiguation. In reparsing, we define very general principles for morpho-syntactic agreement, by defining agreement between single daughter constituents and their mother node, for categories like determiner, adjective, or noun (see Figure 4). This is in contrast to the usual definition of agreement rules between siblings. Since in our reparsing approach constituency is already pre-defined, the agreement constraints can be stated independently from precedence patterns for the recognition of different types of NPs. Defining morphological agreement independently for possibly occurring daughter constituents yields few and very general (disjunctive) projection principles that can also apply to “unseen” constituent sequences.

The rule in Figure 4 again exploits the longest-match strategy to constrain ap-

³with *synsem* a supertype of *lex* and *phrase*, see Section 4.1.

```

agr :-> lex & [NODE [M-ID #mid]]*
      ( lex & [NODE [M-ID #mid], M-SYN [CAT nn, AGR #agr]] |
        lex & [NODE [M-ID #mid], M-SYN [CAT adja, AGR #agr]] |
        lex & [NODE [M-ID #mid], M-SYN [CAT art, AGR #agr]] )
      lex & [NODE [M-ID #mid]]*
-> phrase & [NODE [ID #mid], M-SYN [AGR #agr]].

```

Figure 4: Modular (disjunctive) agreement projection rules.

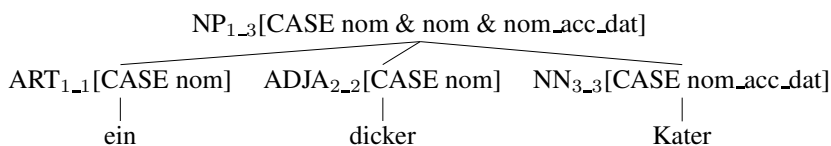

Figure 5: Interaction of morphological constraints.

plication to the pre-defined constituents, by specifying coreferent M-ID features for all nodes in the rule's input sequence. In reparsing, the (possibly disjunctive) morphological types in the output structure of the individual rule applications are unified, yielding partially resolved inflectional features for the mother node. For NP_{1_3} in Figure 2, e.g., we obtain *CASE nom* by unification of *nom* (from ART_{1_1} and $ADJA_{2_2}$) and *nom_acc_dat* (from NN_{3_3}), see Figure 5. This resolved case value of the NP can be used for (underspecified) argument binding in RMRS construction (as discussed in more detail in Section 4.3).

Architecture of the SProUT-XSLT RMRS cascade. SProUT cascades can be defined using the declarative system description language SDL (Krieger, 2003). The sequence of SProUT cascade stages described in this paper has been specified in SDL and integrated into the 'Heart of Gold' (HoG) NLP architecture of Callmeier et al. (2004). HoG provides an XML-based architecture framework for the integration of deep and shallow NLP components. The declaratively defined SDL description of the cascade is compiled into a Java class which is integrated in a HoG architecture instance as a sub-architecture module (Figure 7).

The cascade, displayed in Figure 6, consists of four SProUT grammar instances with four interleaved XSLT transformations. The recursive application of phrase composition rules is defined by means of a cyclic SDL star operator. XSLT is used, e.g., to merge SProUT-generated structures with XML-encoded analyses of the chunk parser Chunkie (Skut and Brants, 1998). Motivation for and further details on XSLT transformation of typed feature structure representations are presented in Schäfer (2004).

```

chunkiermrs = ( sprout_rmrs_morph + xslt_pos_filter + sprout_rmrs_lex
                + ( xslt_nodeid_cat + sprout_rmrs_phrase ) *
                + sprout_rmrs_final + xslt_fs2rmrsxml + xslt_reorder )
sprout_rmrs_morph = sdl.sprout.SproutModulesTextXml("rmrs-morph.cfg")
xslt_pos_filter   = sdl.xslt.XsltModules("posfilter.xsl", "Chunkie")
sprout_rmrs_lex   = sdl.sprout.SproutModulesXmlXml("rmrs-lex.cfg")
xslt_nodeid_cat   = sdl.xslt.XsltModules("nodeinfo.xsl", "Chunkie")
sprout_rmrs_phrase = sdl.sprout.SproutModulesXmlXml("rmrs-phrase.cfg")
sprout_rmrs_final = sdl.sprout.SproutModulesXmlXml("rmrs-final.cfg")
xslt_fs2rmrsxml   = sdl.xslt.XsltModules("fs2rmrsxml.xsl")
xslt_reorder      = sdl.xslt.XsltModules("reorderrmrsdtrs.xsl")

```

Figure 6: SDL definition of the SProUT XSLT cascade.

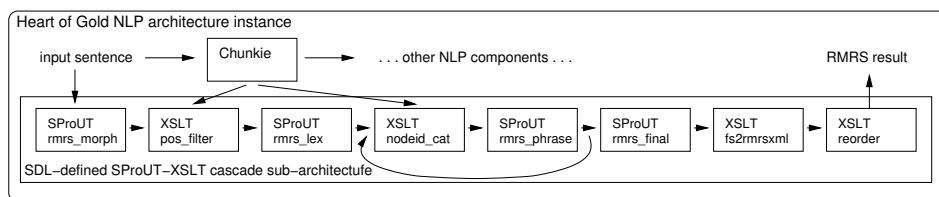

Figure 7: SProUT XSLT cascade in a ‘Heart of Gold’ architecture instance.

4 Semantics Projection Principles for Shallow Grammars

4.1 A Shallow Feature Geometry

The type hierarchy we assume for RMRS construction from shallow grammars specifies expressions as feature structures of type *synsem*, with three main features: the syntactic features *NODE* and *M-SYN*, and the semantic feature *RMRS* (cf. Figure 8.a).

- *NODE* is used to maintain the constituent information that is needed for structure reparsing: It defines the identifier of the local node (*ID*) and the mother node’s identifier and category (*M-ID*, *M-CAT*). These features are referred to in the rules to restrict rule application to entire constituents.
- *M-SYN* values convey morpho-syntactic information, namely the category (*CAT*) and the agreement features *person*, *number*, *gender*, and *case* (in *AGR*). In addition, lexical signs store the results of morphological lookup as (typed) inflectional features embedded under *M-SYN* (cf. section 4.2).
- *RMRS*, of type *rmrs*, introduces four features: *HOOK* stores semantic features (a variable and a label) of a sign’s semantics that need to be externalised for semantics composition; *RELS* is a set containing the elementary predications (EPs) of the local sign; *CONS* is a set of scope constraints of type *qeq*, with features *HI* (for the argument positions of quantifiers or other scope-taking items) and *LO* (for the label of the scoped elementary predication); finally,

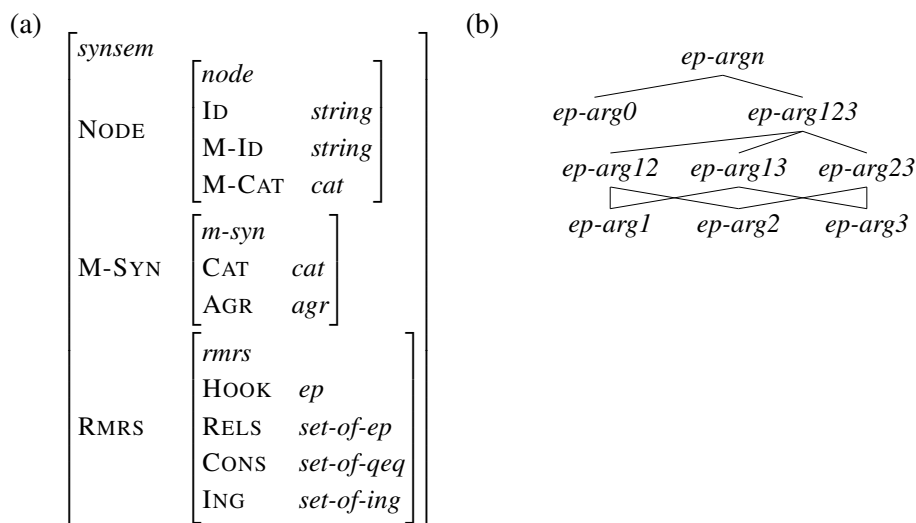

Figure 8: (a) The type *synsem* and (b) the type hierarchy for argument EPs.

ING is used to encode phrasal grouping of labels, as required for coordination or adjectival modifiers, cf. (Copestake, 2003).

Elementary Predications. The basic units for semantics composition are elementary predications (EPs), of type *ep*. They (minimally) define a label LB (of type *lb*) and a variable VAR. Variables are either of type *hole* (subject to *qeq* constraints) or of type *individual*, which is again split into *event-vars* with tense and mood information, and *referential-vars*, carrying PNG information.

We distinguish different subtypes of EPs: *ep-rel* introduces an additional feature REL that specifies the precise semantic relation by means of the lemma, or in terms of general semantic relations (such as *def_rel*, *poss_rel*, etc.);⁴ *ep-rstr* and *ep-body* for quantifiers introduce the features RSTR and BODY, respectively. Arguments are encoded as a supertype *ep-argn* with subtypes for underspecified argument types, as shown in Figure 8.b. Note that a general feature name ARGX, introduced by *ep-arg123*, allows us to specify and refer to arguments in a uniform way, irrespective of their (possibly underspecified) argument type. At the lexical level, the ARG0 value of an *ep-arg0* is coreferent with the externalized variable in HOOK in most cases, depending on the lexical class.

Lexical and phrasal types. The type *synsem* is subdivided into *lex* and *phrase* subtypes. While the latter is simply characterized as having a phrasal CAT value, e.g., one of the atomic types *np*, *vp*, *pp*, *ap*, or *s*,⁵ the former expands to subtypes corresponding to different word classes. These specify how the PoS-specific

⁴*ep-rel* again expands to several subtypes that correspond to (subclasses of) PoS of lexical items. The PoS-specific subtypes are employed for the definition of PoS-specific semantic conditions in lexical semantics construction rules (see below, Section 4.2).

⁵The category types are determined by the input parser’s phrasal category inventory.

morpho-syntactic features (as defined by SProUT’s morphological type system in the feature INFL) are mapped to the more general features AGR and CAT in our sign’s M-SYN feature.

4.2 RMRS construction from lexical nodes

Interfaces for Morphological Lookup and PoS Filtering. The SProUT system performs morphological lookup on the input string in order to retrieve information about inflectional features (case, number, person, gender, mode, and tense), lemmatization, and PoS.⁶ The output structures of morphological processing are (sequences of) TFSs that are based on a hierarchy of (possibly disjunctive) morpho-syntactic types.

Disjunctive types are used for underspecified representation of morphological ambiguities (Krieger and Xu, 2003), instead of atomic disjunctions. Consider, for instance, the German word “Mann” (*man*). This form is ambiguous in that it expresses nominative, accusative or dative case—only genitive (“Mannes”) is excluded. Instead of outputting three distinct structures, the morphological component returns one TFS with the underspecified case value *nom_acc_dat*. Rules for morphological agreement, such as the agreement rule in Figure 4, exploit type unification to reduce this ambiguity. E.g., unification of *nom_acc_dat* with *acc_dat* yields the more restricted type *acc_dat*.

As mentioned above, a general rule integrates the purely morphological information provided by morphology lookup (structures of type *morph*) into the M-SYN feature of lexical signs (cf. the feature geometry of Figure 8.a). The rule’s LHS matches any structure of the pre-defined type *morph* and introduces it as the M-SYN value of the lexical sign that is defined by the RHS of the rule.

```
morph-lookup :> morph & #1 -> lex & [M-SYN #1].
```

If morphological lookup comes across an unknown word, it returns a TFS not of type *morph*, but of type *token*, with unspecified morphological features. The following rule defines how to handle bare tokens:

```
token-lookup:> token & [SURFACE #1]
-> lex & [M-SYN [SURFACE #1,
STEM #1]].
```

This rule acts as a default rule with low priority. Its application is restricted to those parts of the input which fail to match the LHS of the rule *morph-lookup*. Since there is no morphological information to integrate, the token rule simply enriches the lexical synsem with information about the word stem, which we define as identical to the surface form.

⁶For German, SProUT uses the STTS tagset (Schiller et al., 1999), which supports fine-grained distinctions between word classes. Many of these provide important semantic distinctions, such as different types of pronouns or determiners; e.g., PDS for demonstrative pronouns as in “*This* is great.” vs. PDAT for demonstrative determiners (“*This* book is great”).

While morphological ambiguities within a given word class (e.g., noun or adjective) are underspecified by means of disjunctive types, the system delivers disjunctive output structures for words that are ambiguous with respect to their PoS. These disjunctions are preserved by the morph-lookup rule applications.

We cut down this type of ambiguity by interfacing the morphological analyses with the categorial information from the original parse tree. We run an XSLT-stYLESHEET on the rule output, which inserts the category defined by the parser into the CAT feature of the lexical typed feature structures. Since inconsistent structures cannot be matched by any rule, structures with incompatible category specifications are automatically filtered out in the application of the next set of rules.⁷

Moreover, interfacing morphologically enriched lexical structures with the parser's lexical categories provides important word class information for those words that could not be morphologically analysed, and could only be integrated by means of the default token-lookup rule. For these items, we choose the category proposed by the shallow parser for further semantic processing.

Lexical RMRS conditions. Based on the morphologically enriched and PoS-filtered structures, a second rule set introduces lexical RMRS conditions. The individual rules are specific for major PoS lexical classes, again with some special subclasses as provided by the STTS tagset. As an example, we display the rule for common nouns.

```

rmrs-noun:> lex & #lex & [M-SYN [CAT nn,
                                AGR [NUM #num, GEND #gend],
                                INFL infl_noun & [STTS_OPEN_NOUN nn]]]
-> noun-lex & #lex &
    [RMRS [HOOK ep & [LB #lb, VAR #var],
           RELS { ep-rel-noun & [LB #lb],
                  ep-arg0 & [LB #lb,
                              ARG0 ref-var & #var &
                              [PNG [NUMBER #num,
                                    GENDER #gend]]] }]].

```

Figure 9: Lexical RMRS conditions (common nouns).

The rule is restricted to apply to lexical signs of category type *nn*, with the appropriate nominal inflectional features under INFL.⁸ The RHS of the rule specifies the set of EPs for the lexical sign in RELS: it introduces a noun relation (of type *ep-rel-noun*) and a referential arg0-variable in *ep-arg0*, which is enriched with PNG information from the agreement feature. This variable, and the RMRS label that the two EPs share, constitute the semantic HOOK of the lexical sign.

⁷This presupposes an isomorphic mapping from PoS classes defined in the morphology to PoS classes of the parse tree.

⁸In our implementation, these morphological constraints are factored out as special subtypes of *m-syn* (here *map-morph-nn*). Instead of explicit statement of the morphological constraints, we can thus refer to the appropriate *map-morph-<pos>* type to constrain the application of lexical RMRS rules to specific word classes.

Determination of the concrete contents of the RELS feature at this stage crucially depends on the PoS.⁹ The lexical rules for quantifiers, for instance, supply the appropriate EPs of types *ep-rstr* and *ep-body*; possessives introduce an *ep-rel* for the possessive relation, etc.

The output of this level of lexical processing yields RMRSs of the most basic type: Sets of isolated EPs as they can be obtained from a PoS tagger. This bag of “lexical RMRSs” provides the input for the subsequent cascade stages that perform phrasal RMRS composition.

4.3 Content projection principles

RMRS Conditions: Lists vs. Sets. An important issue, in our architecture for semantic composition, is the formal representation of the flat (R)MRS representations. While in theory the values of RELS and CONS are conceived of as sets (or bags), current implementations of typed feature structure formalisms usually do not offer an implementation of sets. MRSs constructed from deep HPSG grammars are therefore represented and processed as (difference) lists.

There have been several approaches to (finite) sets and set unification, some of them extensions to the standard Kasper-Rounds logic for feature structures (e.g., Rounds (1988) or Pollard and Moshier (1990)). Most of them have not been pursued, either due to the the complex nature of the mathematical apparatus, or due to the theoretical and practical complexity (EXPTIME and beyond).

In our approach to semantics construction, independent principles are tailored to specific aspects of semantic composition (e.g., content projection, scoping constraints, or variable binding). Several of these modular principles will apply to the same constituents, and introduce their corresponding semantic constraints. The output structures defined by the individual rules are unified. If the RMRS RELS and CONS features were represented as lists, unification of the output of modular semantics construction rules would in general fail, because list unification is defined by position, and we cannot foresee the relative ordering of semantic predications when different rules apply independently to the same constituent. In our approach, then, we need to represent semantic constraints in RELS, CONS and ING as sets.

In the SProUT system a cheap form of sets (viz. bags) has been implemented that performs *collection*, but not unification of elements into a set (Krieger et al., 2004). That is, the union of two sets $S_1 = \{a_1, b_1\}$ and $S_2 = \{a_2, b_2\}$ will yield the set $S_1 \cup S_2 = \{a_1, b_1, a_2, b_2\}$, whether or not a_1 and a_2 or b_1 and b_2 are unifiable, structurally equivalent, or even identical.

This extension allows us to represent the RMRS features RELS, CONS and ING as sets, and thus to state semantics projection principles in a modular way. The output of the individual semantics projection principles can be unified by set union. To account for the missing unifiability test over set elements, we need to ensure

⁹As a consequence, we obtain PoS-based “default” lexical RMRS conditions for those items that could not be morphologically analysed, but were processed by the token-lookup rule and interfaced with the PoS categories of the parse tree.

that elementary predications are only introduced once. In other words, they need to be sufficiently specified when they are first introduced into the set of semantic constraints. Since RMRS elementary predications are minimal conditions, this can be ensured by appropriate definition of the semantics construction principles.

Structure reparsing for semantic composition. The input to phrasal RMRS composition are sequences of TFSs of type *lex* with isolated lexical RMRS representations, as described in Section 4.2.

The semantic composition of phrases is driven by a general reparsing rule (see Section 3, Figure 3). For each (recursive) application of the phrasal composition rules, the sequence of input TFSs (i.e., the structures built by the previous cascade stage) is enriched with constituency information (ID, M-ID and M-CAT features of NODE) that we extract from the original parse tree by use of an XSLT-stylesheet. By reference to the M-ID features, and given that the system applies longest match, the reparsing rule matches the constituents predicted by the input shallow syntactic parser.¹⁰

This reparsing rule is now extended with additional constraints to define semantic composition of the matched phrases. This includes principles for the projection of semantic conditions from daughter constituents, as well as principles for variable and argument binding, and scopal constraints.

Basic content projection rule. The content projection rule (Figure 10) assembles the elements of the RMRS RELS, CONS and ING features of all daughter constituents. This is specified by a special collection operator $\% \{ feat \}$ which refers to the corresponding values $\% feat$ of the matched constituent phrases. The result structure is defined as the union of the matched $\% feat$ values.

While a classical list representation would require multiple content projection rules—one for each “arity” of daughter constituents—the set representation enables us to state a single content principle that matches an arbitrary number of daughter constituents. The rule applies to any number of daughter constituents and yields the union of the referenced set-valued features as the semantic value for the mother constituent’s feature, here RELS, CONS and ING.

```
cont_proj :-> synsem & [NODE [M-ID #mid],
                       RMRS [RELS %rels, CONS %cons, ING %ing]+
-> synsem & [NODE [ID #mid],
             RMRS [RELS % {rels}, CONS % {cons}, ING % {ing}]].
```

Figure 10: Content projection rule.

The content projection principle is applied to phrasal constituents, and assembles all semantic conditions defined by the daughter constituents to (recursively) define the semantics of phrases. In addition, we define separate principles that conspire

¹⁰An extended version of the rule in Figure 3 accounts for embedded constituents.

to introduce variable and argument binding as well as scopal constraints that can be defined on the basis of syntactic and morpho-syntactic information.

Variable Binding. Binding of referential variables is defined via the semantic HOOK feature, which is used to externalise variables in compositional semantics construction (see Copestake et al., 2001). As we saw in Section 4.2, in lexical RMRSs the HOOK’s variable is in general defined as the internal (ARG0) variable, while in certain cases, such as with adjectives, it is the ARG1 variable that is externalised for referential binding.

The variable binding rule for noun phrases, displayed in Figure 11, refers to the HOOK variables of all daughter constituents of the NP. The rule constrains the referenced variables of all daughters (and all coreferential variables in their lexically defined elementary predications) to be equated. In addition, the rule sets a new HOOK variable for external binding of the phrase, which in the case of noun phrases is identical to the daughter constituents’ equated HOOK variables.¹¹

```
bind_var :> synsem & [NODE [M-ID #mid, M-CAT np], RMRS [HOOK [VAR #var ]]]+
-> phrase & [NODE [ID #mid], RMRS [HOOK [VAR #var]]].
```

Figure 11: Variable binding.

Scope Constraints. The definition of scope constraints by qeq-constraints in CONS is equally mediated by the HOOK feature. The restrictor argument of quantifiers, for instance, takes scope over the head noun. The corresponding qeq constraint relates the restrictor hole argument of the quantifier and the label of the noun head in a qeq relation. In Figure 12 we display the rule for the introduction of the quantifier’s qeq constraint, along with the lexical rule for quantifiers.

In the *rmrs-quant* rule, the quantifier externalises its ARG0 referential variable as the HOOK’s variable (to be used for referential binding), and in addition externalises its main label as the HOOK’s LB value. These HOOK features allow us to introduce the quantifier scoping conditions in the *q_scope* rule. The rule applies to phrases that include a quantifier followed by a noun head. Their respective main labels, *#noun_lb* and *#q_lb*, are externalised as HOOK labels, and can thus be used to introduce the corresponding scope conditions into the phrase’s RMRS representation: we introduce an elementary predication *ep-rstr* for the quantifier’s restrictor argument and a qeq-constraint in CONS, which defines the label of the noun, *#noun_lb*, to be subordinated to the quantifier’s restrictor argument *#rstr*.

¹¹For flat PP structures (as they are typically assumed in shallow parsing, see the tree in Figure 2), we need to separate the binding of referential variables and the definition of the PP’s external HOOK variable. Here, the rule restricts the equation of the daughter’s variables to the non-prepositional daughters, while the HOOK of the phrase is now defined by the preposition’s lexical HOOK variable.

```
bind_var :> prep-lex & [NODE [M-ID #mid, M-CAT pp], RMRS [HOOK [VAR #prep_var]]
  synsem & [NODE [M-ID #mid], RMRS [HOOK [VAR #var ]]]*
  synsem & [NODE [M-ID #mid], RMRS [HOOK [VAR #var ]]]
-> phrase & [NODE [ID #mid], RMRS [HOOK [VAR #prep_var]]].
```

```

q.scope :> quant-lex & [NODE [M-ID #mid], RMRS [HOOK [LB #q_lb]]]
      synsem & [NODE [M-ID #mid]]*
      noun-lex & [NODE [M-ID #mid], RMRS [HOOK [LB #noun_lb]]]
-> phrase & [NODE [ID #mid], RMRS [RELS { ep-rstr & [LB #q_lb, RSTR #rstr] },
      CONS { qeq & [HI #rstr, LO #noun_lb] } ]].

rmrs-quant:> lex & #lex ....
-> quant-lex & #lex &
      [RMRS [HOOK [VAR #var, LB #lb]],
      RELS { ep-rel & [LB #lb],
      ep-arg0 & [LB #lb, VAR #var],
      ep-body & [LB #lb, BODY hole] } ]].

```

Figure 12: Scope constraints (quantifiers).

Argument identification and argument binding. Finally, we define semantic composition rules for the binding of arguments. As discussed in Section 3, argument identification may be marked structurally or morphologically.

In our approach, we can define argument binding rules by way of structural constraints for languages like English, as illustrated in Figure 13.¹² The rules identify structural configurations for a VP-external or VP-internal NP, respectively. By way of morpho-syntactic features for active/passive voice (which can be computed by independent morpho-syntactic rules), we can identify or partially restrict the type of argument to be bound.

```

arg-ident-np-vp :> synsem & [M-SYN.CAT np,
      RMRS.HOOK.VAR #argvar]
      synsem & [M-SYN [CAT vp, PASSIVE -],
      RMRS.HOOK.LB #lb]
-> synsem & [RMRS.RELS { ep-arg1 & [LB #lb, ARGX #argvar]}].

arg-ident-v-np :> synsem *
      synsem & [M-SYN [CAT verb, PASSIVE -],
      RMRS.HOOK.LB #lb]
      synsem *
      synsem & [M-SYN.CAT np,
      RMRS.HOOK.VAR #argvar]
      synsem *
-> synsem & [RMRS.RELS { ep-arg23 & [LB #lb, ARGX #argvar]}].

```

Figure 13: Structural identification of arguments.

The first rule identifies a VP-external NP in active voice and introduces an elementary predication *ep-arg1* which binds the NP's HOOK variable #argvar as the value of the feature ARGX. The second rule illustrates a case of underspecified argument binding. A VP-internal NP argument (in active voice) may be a direct or indirect argument, depending on the verb's subcategorisation frame. Without lexical infor-

¹²We omit the NODE.M-ID constraints for reparsing here and in the following rules.

mation, we cannot resolve this ambiguity, hence the rule introduces an elementary predication for underspecified argument binding, *ep-arg23*.

For languages with morphological identification of arguments, such as German, we can define argument binding principles that make use of morpho-syntactic constraints, most prominently case. In reparsing we apply agreement rules for morphological disambiguation that lead to maximally resolved case features, in terms of disjunctive types (cf. Section 3, Figure 4).

```

arg-ident-nom :> synsem*
  synsem & [M-SYN [CAT np, AGR.CASE #case],
            RMRS.HOOK.VAR #argvar]
  synsem*
  synsem & [M-SYN [CAT verb, PASSIVE -],
            RMRS.HOOK.LB #lb]
  synsem*
  > synsem & [RMRS.RELS {ep-arg1 & [LB #lb, ARGX #argvar]}],
  where type_eq(#case, nom).

arg-ident-nom-acc :> synsem*
  synsem & [M-SYN [CAT np, AGR.CASE #case],
            RMRS.HOOK.VAR #argvar]
  synsem*
  synsem & [M-SYN [CAT verb, PASSIVE -],
            RMRS.HOOK.LB #lb]
  synsem*
  > synsem & [RMRS.RELS {ep-arg12 & [LB #lb, ARGX #argvar]}],
  where type_eq(#case, acc_nom).

```

Figure 14: Morphological identification of arguments.

The rules in Figure 14 apply to sequences of verbs and NP constituents within a phrasal constituent. In the first rule, the case value of the NP constituent is constrained to be of type *nom*, we therefore introduce an EP *ep-arg1* to bind the referential variable of the NP (provided by the HOOK variable *#argvar*). In the second rule we identify an NP constituent with CASE of type *nom_acc*—the variable is thus bound by way of an underspecified argument binding constraint *ep-arg12*.¹³

Note that the rules make use of a so-called “functional operator” to test for type equality: *type_eq(#case, nom_acc)*. Functional operators are a kind of procedural attachment, which allows us to perform tests that extend the power of type unification. The rules need to distinguish fully disambiguated as opposed to underspecified CASE values in order to introduce the appropriate EP argument type. With type unification, however, we cannot *test* for type equality without *stating* type equality.

That is, if in the first rule we were to constrain the case value of the matched phrase by the specification CASE *nom*, a structure with ambiguous case, such as *nom_acc* could be matched and erroneously disambiguated to *nom*. Vice versa,

¹³Disjunctive versions of these rule take care of alternative head-complement serialisations.

the second rule, if specified to match phrases with ambiguous case, e.g., CASE *nom_acc*, would also apply to fully disambiguated phrases of type *nom*.

The SProUT system enables us to define a functional operator for testing type equality—which in this case can be implemented by way of a simple test on string equality.

As with other semantics construction rules, the rules for argument identification are stated independently for specific arguments or configurations of arguments. The output structures of the individual rules are unified, that is, the corresponding argument identification constraints are assembled in the set-valued RELS feature of the resulting phrases.

Content projection from flat structures. A challenge for principle-based RMRS construction from shallow grammars are their flat syntactic structures. They do not, in general, employ strictly binary structures as assumed in HPSG (see e.g., the semantics construction principles in Flickinger et al. (2003)). Constituents may also contain multiple heads, as with flat PP structures (cf. Figure 2). Finally, chunk parsers do not resolve phrasal attachment, and thus provide discontinuous constituents to be accounted for.

In our reparsing approach for semantics construction, the unification-based pattern matching mechanism of the SProUT system provides elegant means to overcome such difficulties. Independent rules can apply to the same phrases to handle individual aspects of semantics construction. Thus, we can state rules that apply to individual constituents of flat structures, irrespective of the number of phrasal constituents. This enables us to state concise rules for morphological agreement and basic content projection. Similarly, we define independent rules to introduce constraints for scopal relations and argument binding.

For multiple-headed constituents we define special rules with adjusted conditions. For instance, we defined a special *bind_var* rule for flat PPs (cf. footnote 12) which combines the PP-rule's definition of the phrasal HOOK and the NP-rule's coreference constraints for the binding of referential variables. Due to the modular design of the semantics construction principles and the regular expression-based definition of rules, only minor adjustments are needed to account for flat PPs in the definition of scope constraints, by admitting an optionally preceding preposition.

A more intricate problem are discontinuous structures for complex NP or PP structures as they are delivered by chunk parsers, where phrasal attachments are not resolved. While the basic internal semantic construction rules for NPs and PPs are unaffected by the discontinuous phrasal structures, the argument binding rules must account for the uncertainty of phrasal attachment. Here, we propose to generate in-group conditions that account for possible attachments, along the lines of (Frank, 2003).

Finally, semantics construction from shallow grammars is intrinsically affected by the non-lexicalised nature of these grammars. Due to the lack of lexical subcategorisation information, the principles for semantic composition—especially ar-

argument binding—differ significantly from the argument binding principles of deep grammars. While in deep grammars, the binding of arguments can be hard-wired in semantic composition rules, by reference to lexically defined argument “slots” (cf. Copestake et al., 2001), argument binding rules for shallow grammars define constraints on co-occurring constituents to identify their argument status, and generate (potentially underspecified) constraints for argument binding. A natural extension for this type of syntax-semantics interface is the integration of external subcategorisation resources that can be consulted to further constrain the principles for argument binding.

5 Conclusion

We presented an architecture for a constraint-based syntax-semantics interface for RMRS construction from shallow grammars. We proposed a reparsing architecture that permits flexible adaptation to the output of different types of shallow parsers, and argued for a unification-based approach to semantics construction, to account for languages that identify arguments on the basis of morphological constraints. Our reparsing approach permits the definition of modular, interacting semantics construction rules that can be tailored to specific properties of the underlying grammars.

We presented an implementation on the basis of the SProUT processing platform (Drozdzyński et al., 2004; Krieger et al., 2004), a finite-state transduction system that operates on sequences of typed feature structures. The combination of a (cascaded) regular expression-based transduction system with typed feature structure unification turned out to provide a powerful and flexible tool for the definition of complex, but modular semantics construction constraints. In particular, we have argued that the availability of sets as a basic data type is a prerequisite for the implementation of modular semantics construction principles. The usage of a typed feature structure formalism with type inheritance permits concise definition of semantics construction principles.

Compared to the RMRS construction method that Copestake (2003) applies to the English PCFG parser of Carroll and Briscoe (2002), the main features of our approach are (i) argument identification via morphological disambiguation and (ii) definition of modular semantics construction principles in a typed unification formalism. Similar architectures for reparsing have been proposed in earlier work for the generation of LFG f-structures from the output of context-free (PCFG) parsers or treebanks (cf. Frank, 2000; Sadler et al., 2000; Frank et al., 2003b; Cahill et al., 2002; Frank, 2003). Finally, similar ideas that aim at a principled account for RMRS construction from shallow grammars have been independently explored in recent work of Lascarides (2003).

In future work, we will compare our semantics construction principles to the general model of Copestake et al. (2001), a formal framework that was designed for principle-based semantics construction from deep grammars.

References

- Becker, M., Drozdzyński, W., Krieger, H.-U., Piskorski, J., Schäfer, U. and Xu, F. 2002. SProUT—Shallow Processing with Unification and Typed Feature Structures. In *Proceedings of the International Conference on Natural Language Processing, ICON-2002*.
- Cahill, A., McCarthy, M., van Genabith, J. and Way, A. 2002. Parsing with PCFGs and Automatic F-Structure Annotation. In M. Butt and T.H. King (eds.), *Proceedings of the LFG 2002 Conference*, Athens, Greece: CSLI Online Publications, Stanford, CA.
- Callmeier, U., Eisele, A., Schäfer, U. and Siegel, M. 2004. The DeepThought Core Architecture Framework. In *Proceedings of the 4th International Conference on Language Resources and Evaluation (LREC) 2004*, pages 1205–1208, Lisbon, Portugal: European Language Resources Association.
- Carpenter, Bob. 1992. *The Logic of Typed Feature Structures*. Tracts in Theoretical Computer Science, Cambridge: Cambridge University Press.
- Carroll, C. and Briscoe, E. 2002. High precision extraction of grammatical relations. In *Proceedings of COLING 2002*, pages 134–140.
- Copestake, A. 2003. Report on the Design of RMRS. Technical Report D1.1a, University of Cambridge, University of Cambridge, UK., 23 pages.
- Copestake, A., Flickinger, D., Sag, I. and Pollard, C. 2003. Minimal Recursion Semantics, ms.
- Copestake, A., Lascarides, A. and Flickinger, D. 2001. An Algebra for Semantic Construction in Constraint-based Grammars. In *Proceedings of the ACL 2001*, Toulouse, France.
- Daum, M., Foth, K.A. and Menzel, W. 2003. Constraint-based Integration of Deep and Shallow Parsing Techniques. In *Proceedings of EACL 2003*, Budapest, Hungary.
- Drozdzyński, W., Krieger, H.-U., Piskorski, J., Schäfer, U. and Xu, F. 2004. Shallow Processing with Unification and Typed Feature Structures — Foundations and Applications. *Künstliche Intelligenz* 1, 17–23.
- Egg, M., Koller, A. and Niehren, J. 2001. The Constraint Language for Lambda Structures. *Journal of Logic, Language, and Information* 10, 457–485.
- Flickinger, D., Bender, E. M. and Oepen, S. 2003. MRS in the LinGO Grammar Matrix: A Practical User’s Guide. Technical Report, Deep Thought Project Deliverable 3.5.
- Frank, A. 2000. Automatic F-structure Annotation of Treebank Trees. In M. Butt and T.H. King (eds.), *Proceedings of the LFG00 Conference*, CSLI Online Publications, Stanford, CA.
- Frank, A. 2003. Projecting LFG F-Structures from Chunks – or (Non-) Configurationality from a Different Viewpoint. In M. Butt and T.H. King (eds.), *Proceedings of the LFG 2003 Conference*, pages 217–237, Albany, New York: CSLI Publications.
- Frank, A., Becker, M., Crysmann, B., Kiefer, B. and Schäfer, U. 2003a. Integrated Shallow and Deep Parsing: ToPP meets HPSG. In *Proceedings of the ACL 2003*, pages 104–111, Sapporo, Japan.

- Frank, A., Sadler, L., van Genabith, J. and Way, A. 2003b. From Treebank Resources to LFG F-Structures. Automatic F-Structure Annotation of Treebank Trees and CFGs Extracted from Treebanks. In A. Abeille (ed.), *Building and Using Syntactically Annotated Corpora*, The Netherlands: Kluwer Academic Publishers.
- Hinrichs, E. and Trushkina, J. 2002. Getting a Grip on Morphological Disambiguation. In S. Busemann (ed.), *Proceedings of KONVENS 2000*, Saarbrücken, Germany.
- Krieger, H.-U. 2003. SDL—A Description Language for Specifying NLP Systems. In *Proceedings of the 3rd AMAST Workshop on Algebraic Methods in Language Processing, AMiLP-3*.
- Krieger, H.-U., Drozdzyński, W., Piskorski, J., Schäfer, U. and Xu, F. 2004. A Bag of Useful Techniques for Unification-Based Finite-State Transducers. In Ernst Buchberger (ed.), *Proceedings of 7th KONVENS*.
- Krieger, H.-U. and Xu, F. 2003. A type-driven method for compacting MMorph resources. In *Proceedings of RANLP 2003*, pages 220–224.
- Lascarides, A. 2003. Robust Construction, manuscript, University of Edinburgh.
- Müller, F. H. 2004. Annotating Grammatical Functions for German Using Finite-Stage Cascades. In *Proceedings of COLING 2004*, pages 268–274, Geneva, Switzerland.
- Pollard, Carl J. and Moshier, M. Drew. 1990. Unifying Partial Descriptions of Sets. In P. Hanson (ed.), *Information, Language, and Cognition. Vol. 1 of Vancouver Studies in Cognitive Science*, pages 285–322, University of British Columbia Press.
- Reyle, U. 1993. Dealing with Ambiguities by Underspecification: Construction, Representation and Deduction. *Journal of Semantics* 10(2), 123–179.
- Rounds, William C. 1988. Set Values for Unification-Based Grammar Formalisms and Logic Programming. Technical Report CSLI-88-129, Center for the Study of Language and Information.
- Sadler, L., van Genabith, J. and Way, A. 2000. Automatic F-Structure Annotation from the AP Treebank. In M. Butt and T.H. King (eds.), *Proceedings of the LFG00 Conference*, University of California, Berkeley, CSLI Online Publications, Stanford, CA.
- Schäfer, U. 2004. Using XSLT for the Integration of Deep and Shallow Natural Language Processing Components. In *Proceedings of the ESSLLI 2004 workshop on Combining Shallow and Deep Processing for NLP*, pages 31–40, Nancy, France.
- Schiller, A. Teufel, S. and Stöckert, C. 1999. Guidelines für das Tagging deutscher Textcorpora mit STTS. Technical Report, University of Stuttgart and Tübingen.
- Skut, W. and Brants, T. 1998. Chunk tagger: statistical recognition of noun phrases. In *ESSLLI-1998 Workshop on Automated Acquisition of Syntax and Parsing*, Saarbrücken.

Linking in constructions

Petter Haugereid 

NTNU Trondheim

Proceedings of the 11th International Conference on
Head-Driven Phrase Structure Grammar

Center for Computational Linguistics, Katholieke Universiteit Leuven

Stefan Müller (Editor)

2004

Stanford, CA: CSLI Publications

pages 414–422

Haugereid, Petter. 2004. Linking in constructions. In Stefan Müller (ed.), *Proceedings of the 11th International Conference on Head-Driven Phrase Structure Grammar*, Center for Computational Linguistics, Katholieke Universiteit Leuven, 414–422. Stanford, CA: CSLI Publications. DOI: 10.21248/hpsg.2004.23. 

Abstract

In this paper I will make an attempt to show how the linking normally done in the lexicon also can be done in constructions. The motivation behind this is the flexibility it gives the grammar writer in underspecifying lexical entries. Being too rigid about linking in the lexicon may lead to unsatisfying results such as multiple lexical entries for what one intuitively feels is just one lexical entry, or alternatively, lexical rules which are not morphologically motivated. The aim is to show that this can be avoided by letting constructions introduce the linking information instead.

1 Introduction

First I will briefly present what I mean by linking in the lexicon. Second I will discuss the kind of semantic representations I will use. Third I will discuss valence features and show how constructions adapted to the function of the argument may be used to introduce linking information. Then I will discuss two problems that turn up when one tries to do linking in the constructions, namely long distance dependencies and linking of subjects.

The fundament for the work presented here is the Matrix Grammar (Bender et al. [2002]) (Version 0.6), which is a subset of the English Resource Grammar (ERG) and which purpose is to give a grammar writer the most basic types needed to write a large coverage HPSG grammar using the LKB system (Copestake [2001]). The Matrix has build into it MRS semantics (Copestake et al. [1999]).

2 Linking in the lexicon

In an active sentence with a ditransitive verb like *give*, there is linking between the ARG1 role of the verb relation and the index of the subject. In addition the index of the direct object is linked to the ARG2 of the verb relation and the index of the indirect object is linked to the ARG3 of the verb relation. Normally this linking is done in the lexicon, and the linking information of a ditransitive lexeme like *give* will look like in figure (1)¹.

One problem about doing linking in the lexicon is that one at an early stage has to decide how many semantic arguments the verb has. In the case of *give*, one will need another lexical entry if one wants to say that that it has only two semantic arguments. Another example is the Norwegian the verb *kaste* (throw) which may be intransitive, transitive and ditransitive. It may also have a particle or a PP as complement. If one wants to decide in the lexicon about the semantic arguments of this verb, one is forced to assume many lexical entries (or lexical rules).

¹The feature KEYREL is a pointer to the main relation in a lexeme.

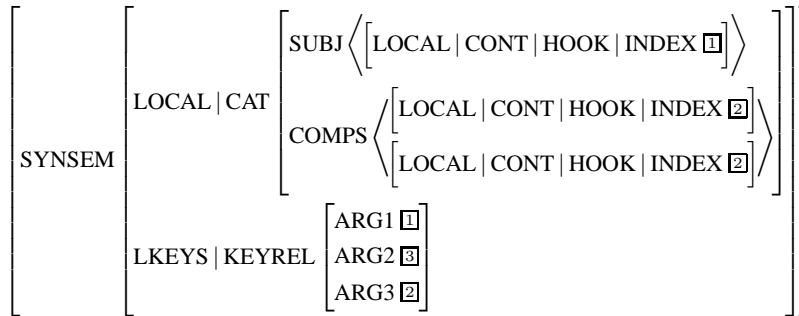

Figure 1: Linking type for ditransitive verbs

3 Decomposed semantics

Instead of doing linking in the lexicon, I would suggest to underspecify lexical entries with regard to linking, and rather do the linking in the constructions. In the following I will use a decomposed semantics called RMRS (Robust Minimal Recursion Semantics) (Copestake [2003]). Argument taking lexemes have a basic relation with a handle (LBL), an index (ARG0) and a PRED feature. There will be other basic relations that link the main relation to its arguments. These relations will have a handle and a feature ARG1, ARG2, ARG3 or ARG4. The semantic representation of the sentence *a man admires a painting* looks like in figure (2)².

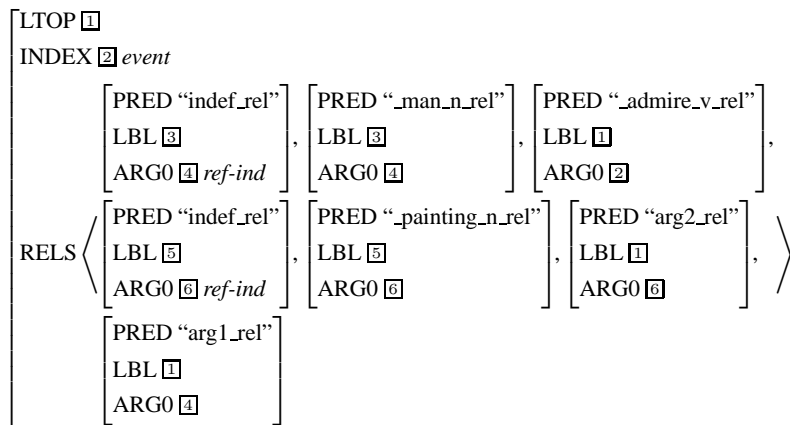

Figure 2: RMRS for “A man admires a painting”

Here the relation of the transitive verb, `_admire_v_rel`, shares handle with the

²Quantifier scope will not be represented in this paper

arg1_rel and the arg2_rel. The representation above is equivalent to the MRS representation in figure (3):

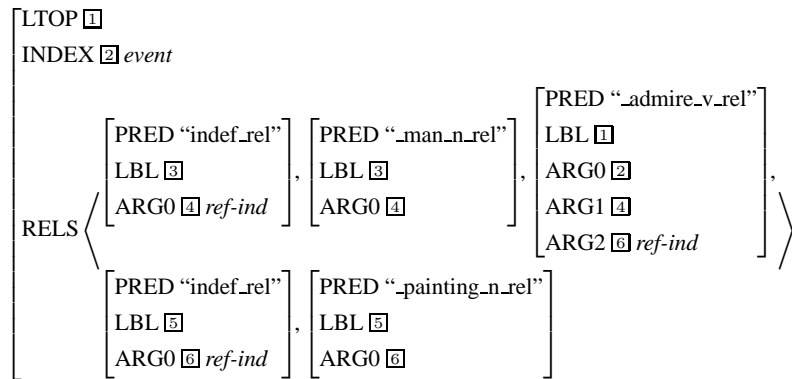

Figure 3: MRS for “A man admires a painting”

4 Valence constructions

In order to make the valence rules introduce linking relations, I will have to make some assumptions about the valence lists. The type *valence* in the Matrix has the following definition:

```

valence := valence-min &
[ SUBJ list,
  SPR list,
  COMPS list,
  SPEC list,
  --KEYCOMP avm ].

```

In this approach the type *valence* is changed:

```

valence := valence-min &
[ SPR list,
  DOBJ list,
  IOBJ list,
  POBJ list ].

```

The two lists SUBJ and SPR are merged into SPR. The COMPS list is divided, so that there is one list for each kind of complement. There is one list for direct objects, one for indirect objects, and one for other complements such as particles and PPs. The SPEC list is taken out.

The decomposed semantics together with the new valence lists allow me to write valence rules that do linking between argument taking signs and their arguments. The rule for direct objects is given in (4)³:

³The exclamation marks on the RELS list mean that the list is a difference list

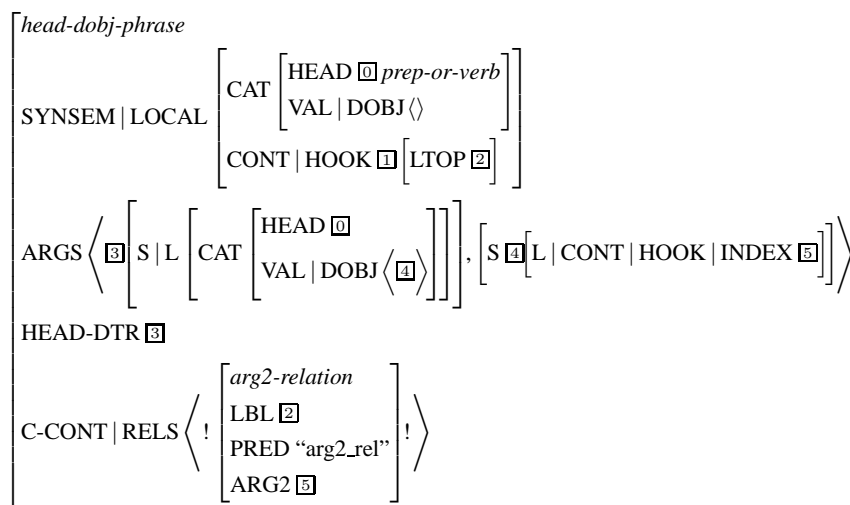

Figure 4: Head direct object rule

The feature C-CONT in a phrase has as value the type *mrs* and it allows the grammar writer to let constructions introduce relations in the same way as lexical entries do. In the phrase above, a linking relation (*arg2-relation*) is introduced in C-CONT. The handle of the linking relation is linked to the LTOP of the phrase. This ensures that it has the same handle as the main relation of the head. The ARG2 of the linking relation is linked to the index of the direct object. This means that the index of the direct object will be the ARG2 of the main relation of the head.

5 Long distance dependencies

One possible problem connected to letting constructions introduce linking relations is long distance dependencies. In long distance dependencies the filler phrase will not have access to information about the function of the filler, and one cannot predict which linking relation it should have. However, this is not a problem if one lets the extraction rule do the linking. In figure (5) I suggest a hierarchy of direct object phrases, where the most essential information is captured in a supertype of the *head-dobj-phrase* and the *extr-dobj-phrase*.

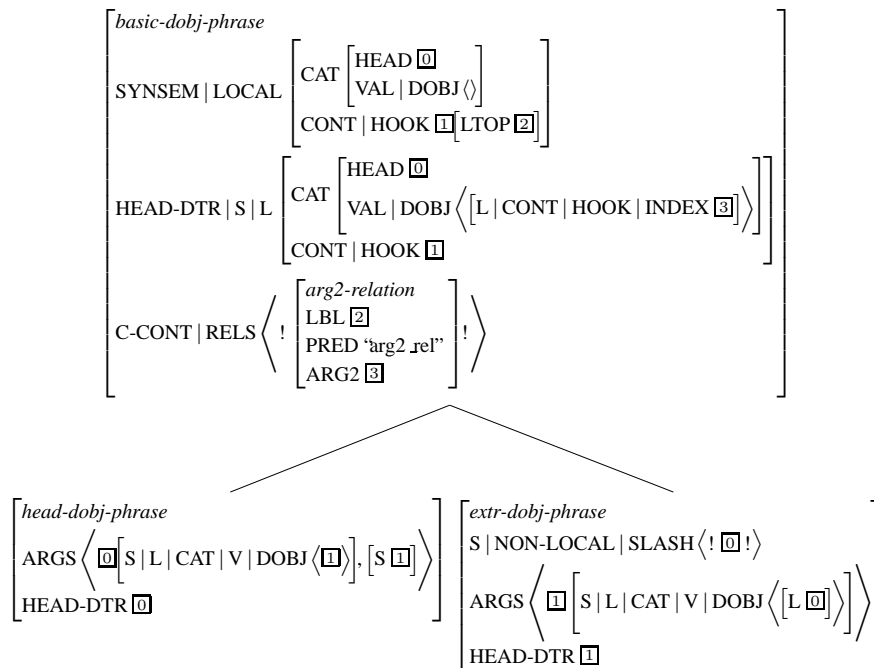

Figure 5: Type hierarchy of direct object phrases

6 Linking of subjects

In this section I will present some problems that subjects in Norwegian raise.

6.1 Presentational constructions

Presentational constructions are very frequent in Norwegian. In presentational constructions the expletive *det* functions as subject. This word is not assumed to have any content, the content that the presentational construction may contribute, can be ascribed the construction, and not the word. Since the expletives don't have any content, there is no need for a linking relation. So I have to assume two kinds of subject rules, one which introduces a linking relation, and one which doesn't. In the first case the subject has a *ref-ind* as an index, and in the second case it will have an *expl-ind*. Then it is an expletive.

6.2 Subjects with content

It is not always the case that subjects with a referential index are in an ARG1 relation to the verb. They can also be in an ARG2 or ARG3 relation to the verb. This

may be the case when the verb has passive voice or it is an ergative. The Norwegian examples (1)-(3) illustrate this fact. The sentences also have presentational counterparts (4) and (5), where the linking should be unproblematic.

- (1) *En mann kommer*
 a man comes
 'A man comes'
- (2) *Mannen blir gitt en kake.*
 man-the becomes given a cake
 'The man is given a cake.'
- (3) *En kake blir gitt mannen.*
 a cake becomes given man-the
 'The man is given a cake.'
- (4) *Det kommer en mann.*
 it comes a man
 'A man comes.'
- (5) *Det blir gitt mannen en kake.*
 it becomes given man-the a cake
 'The man is given a cake.'

In order to account for the different linking relations that can be introduced by the subject rule, I introduce a feature VOICE on *head*. The value of the VOICE feature, *voice* has the feature SPR-CONT. The value of SPR-CONT is *mrs*. The type *head* now has the following information:

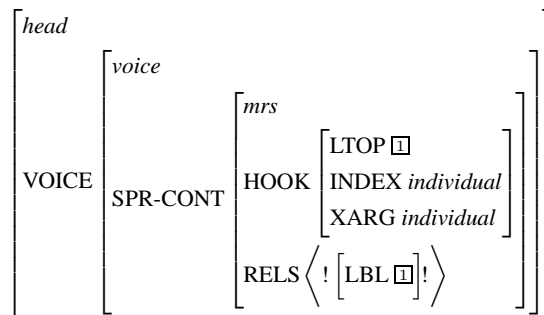

Figure 6: The VOICE feature on the type *head*

The head specifier rule for non-expletive subjects (*content-spr-phrase*) is similar to the direct object rule. Analogous with the direct object phrases, there will be a general specifier phrase that holds for both the *head-spr-phrase* and the *extr-spr-phrase* (7).

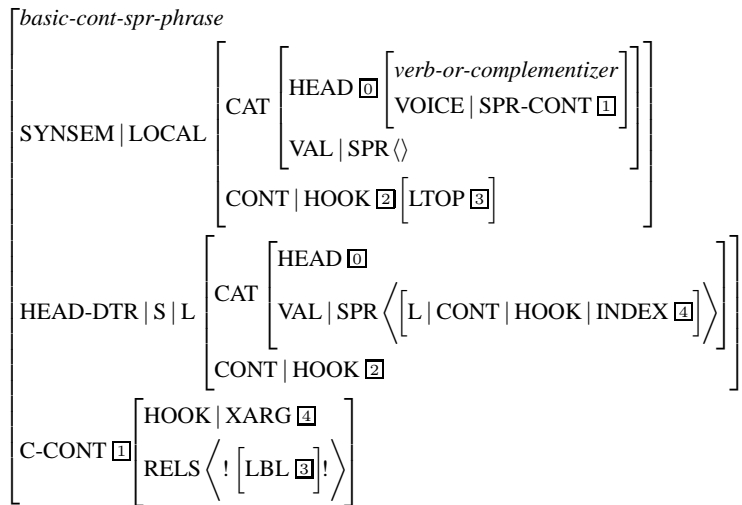

Figure 7: Basic content specifier phrase

The difference is that in this phrase it is underspecified which linking relation is introduced by C-CONT. Instead the C-CONT of the construction is unified with the SPR-CONT of the head projection. Given the hierarchy in (8) and the type definition in (9) we can infer that a sentence with an active agentive verb will get an arg1-relation in the C-CONT of the subject rule.

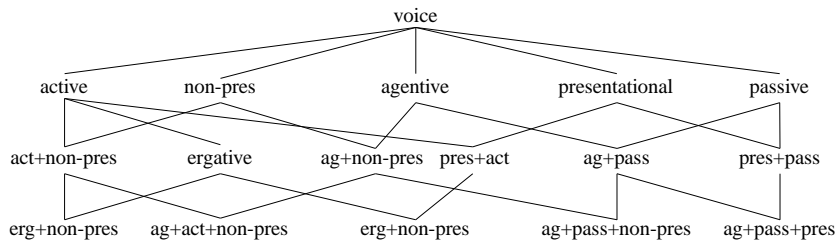

Figure 8: Hierarchy under *voice*

I can also use the new machinery to account for the linking relations for passives and ergatives that have a subject which not an expletive. This can be done by assuming a unary rule that moves one of the objects into the specifier list, constrains the VOICE value to be *non-pres* and specifies the relation in SPR-CONT to be an arg2-relation in case of direct objects, and an arg3-relation in case of indirect objects.

$$\left[\begin{array}{l} \text{ag+act+non-pres} \\ \text{SPR-CONT} \left[\begin{array}{l} \text{HOOK | XARG } \square \\ \text{RELS } \langle ! \left[\text{ARG1 } \square \right] ! \rangle \end{array} \right] \end{array} \right]$$

Figure 9: Type definition of *ag+act+non-pres*

7 Conclusion

I have shown that it is possible to underspecify lexical entries with regard to linking information and still account for phenomena like discontinuous constituents and subjects of ergative and passive verbs.

References

- Emily M. Bender, Daniel P. Flickinger, and Stephan Oepen. The grammar matrix: An open-source starter-kit for the rapid development of cross-linguistically consistent broad-coverage precision grammars. In John Carroll, Nelleke Oostdijk, and Richard Sutcliffe, editors, *Proceedings of the Workshop on Grammar Engineering and Evaluation at the 19th International Conference on Computational Linguistics*, pages 8–14, Taipei, Taiwan, 2002.
- Ann Copestake. *Implementing Typed Feature Structure Grammars*. CSLI Lecture Notes. Center for the Study of Language and Information, Stanford, 2001. URL <http://csli-publications.stanford.edu/site/1575862603.html>.
- Ann Copestake. Report on the design of rmrs (preliminary version). Technical report, Cambridge, April 11, 2003.
- Ann Copestake, Daniel P. Flickinger, and Ivan A. Sag. Minimal recursion semantics: An introduction. URL <http://www-csli.stanford.edu/aac/papers/newmrs.pdf>. Manuscript, Stanford University: CSLI, 1999.

Lexical Resource Semantics: From theory to implementation

Gerald Penn 

University of Toronto

Frank Richter 

Universität Tübingen

Proceedings of the 11th International Conference on
Head-Driven Phrase Structure Grammar

Center for Computational Linguistics, Katholieke Universiteit Leuven

Stefan Müller (Editor)

2004

Stanford, CA: CSLI Publications

pages 423–443

Penn, Gerald & Frank Richter. 2004. Lexical Resource Semantics: From theory to implementation. In Stefan Müller (ed.), *Proceedings of the 11th International Conference on Head-Driven Phrase Structure Grammar, Center for Computational Linguistics, Katholieke Universiteit Leuven*, 423–443. Stanford, CA: CSLI Publications. DOI: 10.21248/hpsg.2004.24. 

Abstract

This paper summarizes the architecture of Lexical Resource Semantics (LRS). It demonstrates how to encode the language of two-sorted theory (Ty2; Gallin, 1975) in typed feature logic (TFL), and then presents a formal constraint language that can be used to extend conventional description logics for TFL to make direct reference to Ty2 terms. A reduction of this extension to Constraint Handling Rules (CHR; Frühwirth and Abdennadher, 1997) for the purposes of implementation is also presented.

1 Introduction

Lexical Resource Semantics (LRS) has already been used in analyses of various syntactic and semantic phenomena on paper,¹ but until now it did not have a computational implementation, in part because standard typed feature logic (TFL) is so ill-suited to the job of serving as the formal basis of a computational language for describing semantics. All is far from lost, however; it turns out to be relatively simple to extend a TFL-based description language to incorporate the primitives required, which we believe will have application to computational semantics extending well beyond LRS. Those primitives are also described here.

Implementations of computational semantics can be accomplished in TFL — Minimal Recursion Semantics (MRS; Copestake et al., 2003) stands as one particularly well-known example of this. Even in MRS, however, structure that encodes embedding constraints (the so-called *qeq* constraints) must be represented alongside the basic components of the semantic terms being constructed, and several necessary “bookkeeping” principles to address free variables, acyclicity etc. must either be stated in the grammar alongside the real principles that are the subject of linguistic investigation, or (as is conventional in MRS) relegated to an extra-grammatical resolution procedure that exists outside TFL altogether. TFL’s own semantic type system also does not provide semantic typing beyond $e \rightarrow t$, and so the richer typing required by all non-trivial theories of semantical form must either be structurally encoded into the object language or forgotten entirely. Indeed, no MRS-based grammar to our knowledge avails itself of any true semantic typing beyond *animate*, *time*, *event* and other $e \rightarrow t$ sorts that are syntactically convenient for the English Resource Grammar.

This is not to say that LRS is merely an alternative to MRS. In some respects, they are simply incomparable. MRS also has no model-theoretic interpretation, serving instead as a sort of front-end for “the real semantics” that is deemed to be

[†]We are greatly indebted to Manfred Sailer for his co-development of LRS, and the insightful feedback he has provided, arising from his ongoing grammar development work with this implementation.

¹These include: negative concord in Polish, sentential (interrogative) semantics in German, the scope of adjuncts in Dutch, the (past) tense system of Afrikaans, and negation in Welsh. See Richter and Sailer (2004) and the references cited therein.

too impractical for the rapid development of large grammars. Parts of the present proposal are probably better thought of as an alternative to the Constraint Language for Lambda Structures (CLLS; Egg et al., 2001), a constraint language over lambda-term trees with linguistically motivated constraints. CLLS's description language, however, has taken shape around a very orthodox view of the syntax-semantics interface as a set of translation rules that augment phrase structure. In our view, *pace* Egg and Erk (2002), making this suitable to HPSG requires more than using typed feature structures in place of atomic categories. Many semantic principles, just as many syntactic principles, are better expressed as universally quantified constraints, and a semantical description language must provide the primitives necessary to accommodate this. CLLS also takes the very traditional view that semantic composition proceeds entirely through beta-reduction. In CLLS, this view brings a certain amount of explicit overhead into the grammar too, in the form of explicit links between lambdas and bound variables. Like MRS and many other underspecified approaches, however, we have been forced to abandon it in recognition of the abundance of concord, discontinuity and proper naming effects from natural language with which it seems irreconcilable.

Section 2 introduces the semantic intuitions behind LRS and the principles that institutionalize them. Section 3 provides further justification (in brief) through some examples of difficult logical form constraints that they enable us to express. Section 4 then presents a constraint language that directly extends standard models of typed feature logic to incorporate Ty2 terms, and shows how to straightforwardly implement this extension using Constraint Handling Rules (CHR; Frühwirth and Abdennadher, 1997) on top of the TRALE system (Penn, 2004).

2 LRS: Fundamental Principles

Although LRS was originally conceived of as a framework-dependent improvement on Flexible Montague Grammar (Hendriks, 1993) implemented within HPSG, it has moved beyond a reconstruction of the Montagovian tradition within TFL. With its combination of techniques derived from model theoretic semantics in the Montagovian tradition, Logical Form (LF) semantics in the generative tradition (von Stechow, 1993), and underspecified processing in computational semantics, LRS now merges insights from several linguistic traditions into a very expressive but computationally feasible framework for natural language semantics.

The architecture of LRS envisages underspecified processing as mediated on the syntactic side by TFL descriptions, and on the semantic side by expressions from a term description language which comprises the necessary devices for scope underspecification as developed in computational semantics. The guiding assumptions behind LRS are that: (a) all semantic and syntactic idiosyncrasies are lexical (including construction type idiosyncrasies), and (b) there is no non-functional semantic contribution from outside of the lexicon. LRS distinguishes between lexical semantics and compositional semantics. Lexical semantics remains under the

CONTENT attribute. CONTENT values are subject to theories of linking, of semantic selection and of HPSG's traditional BINDING THEORY. Compositional semantics, on the other hand, is located in the value of a new attribute LF of signs, and is thus not visible to syntactic and semantic selection by heads. An interface theory which links certain components of the local content to certain parts of the compositional semantics allows for some amount of interaction, such as the lexical selection of the semantic variables of arguments by syntactic heads.

In what follows, we discuss only compositional semantics.² In Section 2.1 we show how to encode the language of two-sorted theory (Ty2; Gallin, 1975) in TFL. This encoding then serves to illuminate the connection between LRS and HPSG in Section 2.2, in which we discuss the constraints which constitute the semantic composition mechanism of LRS. In our computational implementation of LRS (Section 4), the encoding part of the theory disappears entirely and is replaced by providing the terms of Ty2 as first class citizens in the denotation of an appropriately extended description language. The semantic composition mechanism will remain effectively unchanged, however.

2.1 Specification of Ty2

The purpose of this section is to demonstrate how Ty2 can be encoded in a particular version of TFL, Relational Speciate Re-entrant Language (RSRL). Readers not interested in the technical details might skip this section and proceed with Section 2.2.

A specification of Ty2 needs an appropriate signature and a set of constraints which denotes models whose objects correspond to the natural numbers (used as indices of variables and non-logical constants), the types, and the well-formed expressions of Ty2. The signature, Σ_{Ty2} , is shown in Figure 1. It must be part of any signature of a grammar specification in TFL using Ty2 for semantic representations. The sorts, attributes, and relation symbols in Σ_{Ty2} will be explained together with the principles which enforce the well-formedness of the Ty2 expressions in grammar models. They are shown in (1).

- (1) a. The NATURAL NUMBERS PRINCIPLE:

$$integer \rightarrow \exists x^x [zero]$$

- b. The COMPLEX TERM PRINCIPLES:

$$application \rightarrow \left[\begin{array}{l} \text{TYPE } [2] \\ \text{FUNCTOR TYPE } \left[\begin{array}{l} \text{IN } [1] \\ \text{OUT } [2] \end{array} \right] \\ \text{ARG TYPE } [1] \end{array} \right] \quad abstraction \rightarrow \left[\begin{array}{l} \text{TYPE } \left[\begin{array}{l} \text{IN } [1] \\ \text{OUT } [2] \end{array} \right] \\ \text{VAR TYPE } [1] \\ \text{ARG TYPE } [2] \end{array} \right]$$

²See (Sailer, 2004) for a discussion and empirical motivation of the architecture of local semantics in LRS.

$$\begin{array}{ll}
\text{equation} \rightarrow \begin{bmatrix} \text{TYPE } truth \\ \text{ARG1 TYPE } \mathbb{1} \\ \text{ARG2 TYPE } \mathbb{1} \end{bmatrix} & \text{negation} \rightarrow \begin{bmatrix} \text{TYPE } truth \\ \text{ARG TYPE } truth \end{bmatrix} \\
l\text{-const} \rightarrow \begin{bmatrix} \text{TYPE } truth \\ \text{ARG1 TYPE } truth \\ \text{ARG2 TYPE } truth \end{bmatrix} & \text{quantifiers} \rightarrow \begin{bmatrix} \text{TYPE } truth \\ \text{SCOPE TYPE } truth \end{bmatrix}
\end{array}$$

c. The TY2 NON-CYCLICITY PRINCIPLE:³

$$ty2 \rightarrow \forall \mathbb{1} \left(\left(\bigvee \{ [\alpha \ \mathbb{1}] \mid \alpha \in \mathcal{A}_{Ty2} \} \right) \rightarrow \neg \text{ty2-component}(\cdot, \mathbb{1}) \right)$$

d. The TY2 FINITENESS PRINCIPLE:

$$ty2 \rightarrow \exists \mathbb{1} \forall \mathbb{2} (\text{ty2-component}(\mathbb{2}, \cdot) \rightarrow \text{member}(\mathbb{2}, \mathbb{1}[\text{chain}]))$$

e. The TY2 IDENTITY PRINCIPLE:

$$ty2 \rightarrow \forall \mathbb{1} \forall \mathbb{2} (\text{copy}(\mathbb{1}, \mathbb{2}) \rightarrow \mathbb{1} = \mathbb{2})$$

f. The TY2-COMPONENT PRINCIPLE:

$$\forall \mathbb{1} \forall \mathbb{2} \left(\left(\text{ty2-component}(\mathbb{1}, \mathbb{2}) \leftrightarrow \left(\begin{array}{l} \mathbb{1} = \mathbb{2} \vee \\ \bigvee \left\{ \exists \mathbb{3} \left(\begin{array}{l} \mathbb{2}[\alpha \ \mathbb{3}] \wedge \\ \text{ty2-component}(\mathbb{1}, \mathbb{3}) \end{array} \right) \mid \alpha \in \mathcal{A}_{Ty2} \right\} \right) \right) \right)
\end{array}$$

g. The COPY PRINCIPLE:

$$\forall \mathbb{1} \forall \mathbb{2} \left(\left(\text{copy}(\mathbb{1}, \mathbb{2}) \leftrightarrow \left(\begin{array}{l} \bigvee \{ \mathbb{1}[\sigma] \wedge \mathbb{2}[\sigma] \mid \sigma \in \mathcal{S}_{Ty2} \} \wedge \\ \bigwedge \left\{ \forall \mathbb{3} \left(\begin{array}{l} \mathbb{1}[\alpha \ \mathbb{3}] \rightarrow \\ \exists \mathbb{4} (\mathbb{2}[\alpha \ \mathbb{4}] \wedge \text{copy}(\mathbb{3}, \mathbb{4})) \end{array} \right) \mid \alpha \in \mathcal{A}_{Ty2} \right\} \right) \right) \right)
\end{array}$$

h. The SUBTERM PRINCIPLE:

$$\forall \mathbb{1} \forall \mathbb{2} \left(\text{subterm}(\mathbb{1}, \mathbb{2}) \leftrightarrow \left(\begin{array}{l} \mathbb{1}[\text{me}] \wedge \mathbb{2}[\text{me}] \wedge \\ \text{ty2-component}(\mathbb{1}, \mathbb{2}) \end{array} \right) \right)$$

The meaningful expressions of Ty2 are simple or complex expressions in the denotation of the sort *me*. Objects in the denotation of *me* have an attribute TYPE, whose value indicates the type of the expression. If it is a simple expression (a *variable* or a non-logical *constant*), it is indexed by a natural number, which is the value of the attribute NUM-INDEX.

The NATURAL NUMBERS PRINCIPLE, (1a), guarantees the correspondence of objects in the denotation of *integer* to the natural numbers. An *integer* configuration in models of Γ_{Ty2} is either a *zero* entity or a *non-zero* entity on which a term consisting of a finite sequence of PRE attributes is defined whose interpretation on the *non-zero* entity yields an entity of sort *zero*. The number of PRE attributes in

³The symbol \mathcal{A}_{Ty2} denotes the set of attributes of the signature Σ_{Ty2} . Similarly, \mathcal{S}_{Ty2} in (1g) denotes the set of maximally specific sorts of Σ_{Ty2} .

ty_2
me TYPE *type*
variable NUM-INDEX *integer*
constant NUM-INDEX *integer*
application FUNCTOR *me*
ARG *me*
abstraction VAR *variable*
ARG *me*
equation ARG1 *me*
ARG2 *me*
negation ARG *me*
l-const ARG1 *me*
ARG2 *me*
disjunction
conjunction
implication
bi-implication
quantifiers VAR *variable*
SCOPE *me*
universal
existential
type
atomic-type
entity
truth
w-index
complex-type IN *type*
OUT *type*
integer
zero
non-zero PRE *integer*
Relations
append/3
copy/2
member/2
subterm/2
ty2-component/2

Figure 1: The signature Σ_{Ty_2} for a grammar of Ty2 expressions

this term corresponds to the natural number represented by the configuration under the *non-zero* entity.

The six COMPLEX TERM PRINCIPLES, (1b), are responsible for the proper typing of complex Ty2 expressions. These are the *application* of a functor to an argument ($(\alpha_{\langle\tau',\tau\rangle}(\beta_{\tau'})_{\tau})$), lambda *abstractions* ($(\lambda v_{n,\tau'}.\alpha_{\tau})_{\langle\tau',\tau\rangle}$), *equations* ($(\alpha_{\tau} = \beta_{\tau})_t$), negated expressions ($(\neg\alpha_t)_t$), expressions formed from two meaningful expressions by conjoining them with a logical connective (e.g., $(\alpha_t \wedge \beta_t)_t$), and quantificational expressions (e.g., $(\exists v_{n,\tau}\alpha_t)_t$). In models of the TFL grammar the correct typing of the meaningful expressions, indicated in the examples given in parentheses with the type t (for *truth*) and the meta-variable τ , is guaranteed by the COMPLEX TERM PRINCIPLES.

The remaining principles fall in two groups: the task of the principles (1c)–(1e) is to guarantee the well-formedness of the *ty2* configurations in grammar models in the sense that all *ty2* configurations correspond to Ty2 expressions (or natural numbers and types); the remaining three principles, (1f)–(1h), determine the meaning of relation symbols which are needed either in the preceding three principles or in Section 2.2 in the composition principles of LRS. According to (1f) the relation *ty2-component* holds between each pair of Ty2 objects $\boxed{1}$ and $\boxed{2}$ such that either $\boxed{1}$ and $\boxed{2}$ are identical or $\boxed{1}$ is a component of $\boxed{2}$ (i.e., $\boxed{1}$ can be reached by starting from $\boxed{2}$ and following a finite sequence of attributes). With (1g), two Ty2 objects $\boxed{1}$ and $\boxed{2}$ in an expression are in the *copy* relation iff the configurations of objects under them are isomorphically configured: they all have the same attributes and corresponding attribute values of the same sorts. The *subterm* relation, determined by (1h), will be particularly important in Section 2.2. It holds between each pair of *me* objects $\boxed{1}$ and $\boxed{2}$ iff $\boxed{1}$ is a subterm of $\boxed{2}$. For perspicuity we will use an infix notation below and write ' $\boxed{1} \triangleleft \boxed{2}$ ' for *subterm*($\boxed{1}, \boxed{2}$). The *append* and *member* relation symbols, which also belong to the signature Σ_{Ty2} in Figure 1, receive their usual interpretation. We omit the principles defining their intended meaning.

The TY2 NON-CYCLICITY PRINCIPLE, (1c), excludes the possibility of cyclic term configurations. Cyclic terms (and types) are terms which contain themselves as components. Since it is not clear what cyclic configurations of this kind should correspond to in two-sorted type theory, they have to be excluded from our models. The TY2 FINITENESS PRINCIPLE, (1d), uses the finiteness of *chains* in RSRL to enforce the finiteness of *ty2* configurations. The last principle, the TY2 IDENTITY PRINCIPLE in (1e), enforces a kind of extensionality in our models of Ty2 expressions. It requires that any two isomorphic subconfigurations in a *ty2* configuration be actually identical. For example, if the first variable of type s , $v_{s,0}$, occurs more than once in a Ty2 expression, its corresponding model (as determined by our constraints) will contain exactly one configuration of objects representing $v_{s,0}$.⁴

⁴For an extensive discussion and concrete examples of models, see (Richter, 2004). Sailer (2003) proves that the RSRL specification of Ty2 sketched here is correct.

2.2 Semantic Composition

For the purpose of illuminating the connection between LRS and HPSG in a familiar way, one can think of LRS in terms of a simple TFL specification. The signature of the RSRL encoding of an LRS grammar contains the following attributes, sorts and appropriateness specifications:

- (2) The sort *lrs* (LF value of signs)

<i>lrs</i>	EX(TERNAL-)CONT(ENT)	<i>me</i>
	IN(TERNAL-)CONT(ENT)	<i>me</i>
	PARTS	<i>list(me)</i>

From the previous section we know that the objects in the denotation of the sort *me* are the elements of the set of well-formed expressions of Ty2. The crucial difference between systems such as Flexible Montague Grammar and LRS is that the former employs the lambda calculus with (intensional) functional application and beta-reduction for semantic composition. Semantic composition in LRS builds on a tripartite distinction between internal content, external content and the semantic contribution(s) of a sign to the overall semantic representation of an utterance. While external and internal content are substantive concepts, the representation format of PARTS as a list of *mes* is an artifact of the LRS encoding in TFL. Rather than thinking of PARTS values as lists of expressions, it is more accurate to view them as the specification of those nodes of the term graph of a Ty2 expression which are contributed to the meaning of the natural language expression by the given sign. Only the topmost node of each element on PARTS counts as being contributed.

The internal content of a sign is the scopally lowest semantic contribution of the semantic head of the sign. Its membership in PARTS characterizes it as a necessary contribution of meaning to each syntactic head.

- (3) The INCONT PRINCIPLE (IContP):

In each *lrs*, the INCONT value is an element of the PARTS list and a component of the EXCONT value.

$$lrs \rightarrow \left(\left[\begin{array}{l} \text{EXCONT} \quad \boxed{1} \\ \text{INCONT} \quad \boxed{2} \\ \text{PARTS} \quad \boxed{3} \end{array} \right] \wedge \text{member}(\boxed{2}, \boxed{3}) \wedge \boxed{2} \triangleleft \boxed{1} \right)$$

The external content of a sign is the meaning contribution of its maximal projection to the meaning of the overall expression. When a sign enters into a syntactic construction as a non-head, its external content must have been contributed in the completed syntactic domain:

- (4) The EXCONT PRINCIPLE (EContP):

- a. In every phrase, the EXCONT value of the non-head daughter is an element of the non-head daughter's PARTS list.

$$phrase \rightarrow \left(\left[\begin{array}{l} \text{NH-DTR LF} \\ \text{EXCONT} \quad \boxed{1} \\ \text{PARTS} \quad \boxed{2} \end{array} \right] \wedge \text{member}(\boxed{1}, \boxed{2}) \right)$$

- b. In every utterance, every subexpression of the EXCONT value of the utterance is an element of its PARTS list, and every element of the utterance's PARTS list is a subexpression of the EXCONT value.

$$u\text{-sign} \rightarrow \left(\begin{array}{c} \forall \boxed{1} \forall \boxed{2} \forall \boxed{3} \forall \boxed{4} \\ \left(\left[\begin{array}{c} \text{LF EXCONT } \boxed{1} \\ \text{PARTS } \boxed{2} \end{array} \right] \wedge \boxed{3} \triangleleft \boxed{1} \wedge \text{member}(\boxed{4}, \boxed{2}) \right) \rightarrow \\ \left(\text{member}(\boxed{3}, \boxed{2}) \wedge \boxed{4} \triangleleft \boxed{1} \right) \end{array} \right)$$

The external content value of an utterance is its logical form in the traditional sense. According to the second clause of the EContP, which is a kind of closure principle, the logical form comprises all and only the meaning contributions of the lexical elements in the utterance.

The LRS PROJECTION PRINCIPLE makes the internal and external content locally accessible throughout head projections, and it guarantees that the meaning contributions of all subsigns of a sign will be collected.

(5) LRS PROJECTION PRINCIPLE:

In each *headed-phrase*,

- a. the EXCONT value of the head and the mother are identical,

$$phrase \rightarrow \left[\begin{array}{c} \text{LF EXCONT } \boxed{1} \\ \text{H-DTR LF EXCONT } \boxed{1} \end{array} \right]$$

- b. the INCONT value of the head and the mother are identical,⁵

$$phrase \rightarrow \left[\begin{array}{c} \text{LF INCONT } \boxed{1} \\ \text{H-DTR LF INCONT } \boxed{1} \end{array} \right]$$

- c. the PARTS value contains all and only the elements of the PARTS values of the daughters.

$$phrase \rightarrow \left(\left[\begin{array}{c} \text{LF PARTS } \boxed{1} \\ \text{H-DTR LF PARTS } \boxed{2} \\ \text{NH-DTR LF PARTS } \boxed{3} \end{array} \right] \wedge \text{append}(\boxed{2}, \boxed{3}, \boxed{1}) \right)$$

The SEMANTICS PRINCIPLE (SP) specifies restrictions on how to combine the meaning contributions of different types of syntactic and semantic daughters. For each kind of meaning composition which introduces subterm restrictions, the SP specifies a clause. The primary task of these clauses is to state mutual embedding constraints between the terms of each syntactic daughter. If the relative embedding of the meaning contributions is not fixed deterministically, we achieve a descriptive underspecification of readings:

(6) SEMANTICS PRINCIPLE (SP):

⁵We take the noun to be the head of a quantified NP.

1. if the non-head is a quantifier then its INCONT value is of the form $Qx[\rho \circ \nu]$, the INCONT value of the head is a component of ρ , and the INCONT value of the non-head daughter is identical with the EXCONT value of the head daughter,

$$[\text{NH-DTR SS LOC CAT HEAD } det] \rightarrow \left(\left[\begin{array}{l} \text{H-DTR LF} \left[\begin{array}{l} \text{EXCONT } \boxed{1} \\ \text{INCONT } \boxed{2} \end{array} \right] \\ \text{NH-DTR LF } \boxed{1} \left[\begin{array}{l} \text{INCONT } \left[\begin{array}{l} \text{quantifiers} \\ \text{SCOPE } \left[\begin{array}{l} l\text{-const} \\ \text{ARG1 } \boxed{3} \end{array} \right] \end{array} \right] \end{array} \right] \end{array} \right] \wedge \boxed{2} \triangleleft \boxed{3} \right)$$

2. if the non-head is a quantified NP with an EXCONT value of the form $Qx[\rho \circ \nu]$, then the INCONT value of the head is a component of ν ,

$$\forall \boxed{1} \left(\left[\begin{array}{l} \text{NH-DTR} \left[\begin{array}{l} \text{SS LOC CAT} \left[\begin{array}{l} \text{HEAD } \textit{noun} \\ \text{SUBCAT } \langle \rangle \end{array} \right] \\ \text{LF EXCONT} \left[\begin{array}{l} \text{quantifiers} \\ \text{ARG2 } \boxed{1} \end{array} \right] \end{array} \right] \right] \rightarrow \left(\begin{array}{l} \exists \boxed{2} \\ \left[\begin{array}{l} \text{H-DTR LF INCONT } \boxed{2} \\ \wedge \boxed{2} \triangleleft \boxed{1} \end{array} \right] \end{array} \right) \right)$$

3. [clauses for adverbial modifiers, markers, fillers, ...]

2.3 An Example

With the LRS principles of Section 2.2 we can now analyze sentences with quantifier scope ambiguities such as *Every student reads a book*. In a first approximation, we would like to assign the two readings in (7b) and (7c) to this sentence:

- (7) a. Every student reads a book.
- b. $\lambda w. \exists e \exists y (\text{book}'(w, y) \wedge \forall x (\text{student}'(w, x) \rightarrow \text{read}'(w, e, x, y)))$
- c. $\lambda w. \exists e \forall x (\text{student}'(w, x) \rightarrow \exists y (\text{book}'(w, y) \wedge \text{read}'(w, e, x, y)))$

In the first reading, (7b), the existential quantifier of *a book* takes wide scope over the universal quantifier of *every student*. There is one particular book which every student reads. In (7c) the scope relation of the two quantifiers is reversed. Every student reads a book, but it is not necessarily the same book. We write w for the first variable of type s and use intuitive names for non-logical constants, such as $\text{student}'$, book' and read' . The variable e is a Davidsonian event variable.

Figure 2 illustrates how an LRS grammar of English licenses the two readings of sentence (7a). Because of the perspicuity of the computational description language of LRS, we do not use RSRL descriptions of *lrs* objects at the nodes of the syntactic tree in the figure. Instead we use the description language of the LRS implementation language to be introduced in Section 4. In this language *lrs* descriptions are notated as Ty2 expressions augmented with a small inventory of

additional symbols. The figure depicts the LRS specifications of the lexical entries of an implemented grammar and the information about the *lrs* of each phrase which can be derived according to the LRS principles of the previous section.

In the implementation language $\hat{\alpha}$ means that the (possibly augmented) Ty2 expression α is the EXCONT value of the sign's *lrs*. The INCONT value is notated between curly brackets, $\{\beta\}$. Square brackets signal a subterm relationship. $\alpha[\beta]$ (or, equivalently, $\alpha : [\beta]$) means that β is a subterm of α . We write $[\beta]$ if we do not know anything about an expression except that β is a subterm of it.

At the two NP nodes, Clause (1) of the SEMANTICS PRINCIPLE requires the internal content of the head ($\text{student}(w, X)$ and $\text{book}(w, Y)$) to be in the restrictor of the universal and the existential quantifier, respectively. At the VP and S nodes, it is Clause (2) that brings the internal content of the verbal head ($\text{read}(w, e, X, Y)$) in the scope of both quantifiers.

As an effect of the EContP, we know the external contents of the non-heads in all phrases: At the NP nodes, the external content of the determiners is identical to their internal contents, as these are the only elements being contributed that contain the internal contents as their subexpression. Being contributed is the same as being on the PARTS list in the RSRL specification. In the implementation, every (sub-)expression mentioned counts as being contributed, unless explicitly marked otherwise. At the VP node (and analogously at the S node), the external content of the NP *some book* must be identical to that of the determiner: this is the only element being contributed by the NP that satisfies the condition expressed in the lexical entry of *book*, i.e., that the external content be a quantifier that binds the variable y . Note that the lexical entry of *book* has a meta-variable, Y , in the argument slot of type *entity*. The local selection mechanism, not depicted here, is responsible for identifying the variable y , contributed by the existential quantifier, with Y .

At the S node, the second clause of the EContP applies, i.e., the expressions being contributed specify exactly the expressions which can be used in the resulting logical form. There are exactly two Ty2 expressions which are compatible with the contributions and structural requirements of the lexical entries and that also fulfill the subexpression requirements given by the SEMANTICS PRINCIPLE. Either the universal quantifier of *every student* is in the nuclear scope of the existential quantifier of *a book*, or *vice versa*.

3 LF Constraints

The linguistic rationale behind the architecture of LRS is evidenced by the smooth integration of: (I) “typical” LF constraints such as quantifier island constraints, (II) a straightforward and novel account of negative concord (or multiple exponents) phenomena, and (III) a treatment of traditionally problematic LF discontinuities, thus integrating insights from the generative literature on the syntax-semantics interface in terms of Logical Forms. LRS reanalyzes these insights in terms of the additional expressive flexibility provided by a truly constraint-based grammar frame-

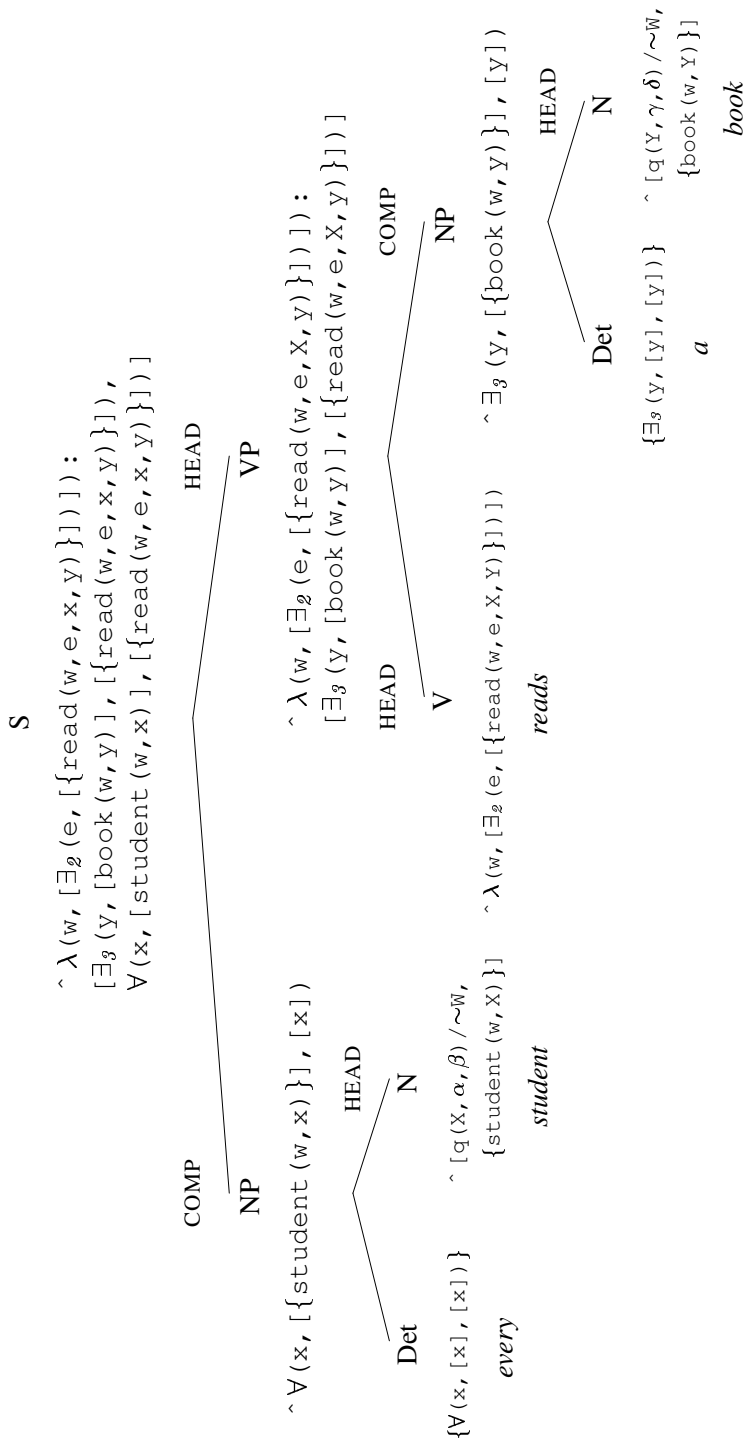

Figure 2: The sentence *Every student reads a book*

work. With a systematic account of typical LF constraints, LRS goes beyond the data analyzed in alternative frameworks used in HPSG such as MRS or UDRT.

For reasons of space, we will give only a very brief and abstract overview of the types of LF constraints for which LRS is designed, and we do not discuss concrete examples in this paper. Quantifier islands (type I constraints) are discussed in (Sailer, 2003, pp. 58–61). A comprehensive empirical motivation for the “multiple exponent” analysis of negative concord in Polish (type II constraints) and an explicit LRS analysis thereof are provided in (Richter and Sailer, 2004, pp. 115–126). Examples of LF discontinuities (type III constraints) and their LRS analysis are discussed in (Richter and Sailer, 2004, pp. 126–131) and in (Richter, 2004, Chapter 6).

A typical LF constraint of type I concerns *quantifier islands*: A universal quantifier may not take scope outside of the clause in which it is realized overtly. As a constraint this is usually regarded as odd, since existential quantifiers in embedded contexts may outscope opaque matrix predicates, producing so-called *de-re* readings. LRS can state restrictions on the scope of quantifiers naturally. They do not differ from any ordinary syntactic restriction in HPSG. Another source of type I LF constraint is statements that postulate that *no quantifier (of a certain type) may intervene* in the logical form between two given logical operators. Conversely, we might require that between a negation operator and some constant only certain quantifiers may intervene.

Type II constraints take advantage of HPSG’s concept of token identity for a novel description of puzzling facts such as negative concord in Romance languages or in Polish. The NEG CRITERION restates a principle of Haegeman and Zanuttini (1991) from a new perspective: For every verb, if there is a negation in the EXCONT value of the verb that has scope over the verb’s INCONT value, then that negation must be an element of the verb’s PARTS list. In other words, if there is a negation with scope over the verb in the verbal projection, the verb itself must also contribute the very same negation. Similarly, the NEGATION COMPLEXITY CONSTRAINT for Polish expresses an insight in terms of LRS which Corblin and Tovenà (2001) found to hold for many languages: For each sign, there may be at most one negation that is a component of the EXCONT value and has the INCONT value as its component. This expresses a (language-dependent) upper bound on the number of negations taking scope over each other and over the main verb of sentences. It also relies on the possibility that, in negative concord languages, negations contributed by different lexical items might be identified with each other in the semantic representation. A third principle which builds on the fact that the same meaning component might be contributed by several lexical elements is the WH-CRITERION (for German, Richter and Sailer, 2001, p. 291): In every clause, if the EXCONT value is of the form $\lambda p.\phi$, then the EXCONT value of the clause must be contributed by the topicalized sign (again rephrasing a well-known principle from the literature). Similar “multiple exponent” effects were found in the LRS analysis of tense in Afrikaans.

LF discontinuities (III) are a lexical phenomenon: A lexical element might

make meaning contributions to a sentence that must be realized discontinuously in the logical form of the overall expression to which they belong. The intervening meaning components are unpredictable and can not be stated in a finite list. Analyses of these phenomena are typically provided by underspecification formalisms which allow for decomposing the logical contributions of lexical items and leaving slots for inserting other pieces of representations.

4 Formal Specification

A formal specification of the core principles of LRS requires a term description language for Ty2 with an is-component-of relation (α is a subterm of β), meta-variables, which, for us, are the variables of the TFL, and a way of attributing semantic “contribution” by lexical items. It also requires a set of axioms for well-formed expressions of Ty2 (which we have presented in Section 2.1), as well as four HPSG principles for IContP, EContP, LRS PROJECTION PRINCIPLE and SP themselves (Section 2.2). Note the absence of beta-reduction from the formalism.

This core of the LRS architecture allows one to assign to each sentence a logical representation with a model-theoretic interpretation; it uses descriptive underspecification to assign to each well-formed utterance one or more fully specified logical form(s) as its meaning representation. If an utterance is n -ways ambiguous, the denotation of the grammar will contain n models of it which differ at least in their meaning representation. In keeping with the tradition of logical form semantics, however, the semantical components of these utterances are modelled by Ty2 *terms*, not the entities of Ty2’s models themselves; thus, no extra expressive power beyond TFL’s model theory is actually required.

Formally, we augment TFL’s model theory with four additional partial functions:

$$\begin{aligned} \text{sem} &: U \rightarrow \text{Ty2} \\ \text{incont} &: U \rightarrow \text{Ty2} \\ \text{excont} &: U \rightarrow \text{Ty2} \\ \text{contrib} &: \text{Ty2} \rightarrow \mathcal{P}(U) \end{aligned}$$

where U is the universe of the TFL model. If *sem*, *incont* and *excont* were features in the signature of TFL, they would be interpreted by functions mapping U to U . These functions, however, allow us to refer instead to a separate collection of entities that model the structure of Ty2 terms. *Sem* is the principal means of access to this collection, potentially associating any entity in the model with a Ty2 term, i.e., a semantics. In practice, this association probably only occurs with signs, and *sem* replaces the LF attribute. Any entity can additionally have *incont* and *excont* values, which in practice are employed in accordance with the intuitions of LRS. Among other things, this means that these values, where they exist, will typically be subterms of the term that *sem* refers to. *Contrib* conversely attributes every Ty2 term in the image of *sem* to the entities that contributed it.

4.1 Constraint Language

Once this model is in place, we need a syntax to refer to it. Augmenting the standard sorts-and-features signature of an HPSG description language, we add to it a collection of semantic type declarations, such as shown in Figure 3. These decla-

```

semtype [t, f]: t.
semtype [student, book]: (s->e->t) .
semtype read: (s->e->e->e->t) .
semtype [every, some]: (e->t->t->t) .
semtype w: var(s) .
semtype q: findom [every, some] .
semtype [a, e, x, y, z]: var(e) .
semtype lambda: (var(A)->B->(A->B)) .

```

Figure 3: An example `semtype` signature.

rations declare the semantic constants and semantic variables that can then be used in our Ty2 terms. Our description language does not stipulate the basic types of the semantic type system (above, `t`, `e`, and `s`), but it does allow for functional closure. Notice that even `lambda` is just another constant, although it has a polymorphic functional type. There is no reason to distinguish it because beta-reduction has no distinguished role in this semantics — if it were desired, it would need to be encoded as a relation or phrase-structure rule just as any other transformation. The `var/l` operator distinguishes semantic variables from semantic constants. This distinction is important because, although there is no beta-reduction, there is still alpha-renaming within variable scope, which we define to be the same as the scope of TFL variables in descriptions. Constants are unique and never renamed. In the example above, `q` is a finite domain variable — an instance of it stands for one of either `every` or `some`.

Having enhanced the signature, we are then in a position to enhance a TFL description language with extra LRS descriptions. Given a countably infinite collection of meta-variables (V), the LRS descriptions (χ) are the smallest set containing:

- the semantic constants of the signature,
- the semantic variables of the signature,
- applications, $f(\chi_1, \dots, \chi_n)$, where
 - $\text{semtype}(f) = \rho_1 \rightarrow \dots \rightarrow \rho_n \rightarrow \tau$,
 - $\text{semtype}(\chi_i) = \rho_i$, all $1 \leq i \leq n$, and
 - τ can be any type (functional or not),⁶

⁶Thus, the case of $n = 0$ is already covered by including the semantic constants.

- meta-variable binding: $V:\chi$,
- subterm binding: $\chi_0 : [\chi_1, \dots, \chi_n]$,
- subterm chain: $V_{top} \sim V_{bottom}$,
- *incont* binding: $\{\chi\}$,
- *excont* binding: $\hat{\chi}$,
- contribution: $\chi/+V$,
- unique contribution: χ/V ,
- negative contribution: $\chi/ \sim V$, and
- implication: $\backslash/S : \chi_S \longrightarrow \chi$.

Because these are included in the closure of the TFL description language, they can be conjoined and disjoined with conventional TFL descriptions, and they can also be applied at feature paths. In the interpretation, however, while TFL descriptions constrain the choice of element $u \in U$ directly, LRS descriptions mostly constrain our choice of $\text{sem}(u) \in Ty2$. *Incont* and *excont* binding instead constrain our choice of $\text{incont}(u) \in Ty2$ and $\text{excont}(u) \in Ty2$, and the contribution constraints constrain our choice of the elements of $\text{contrib}(\text{sem}(u)) \subseteq \mathcal{P}(U)$.

Subterm binding, $\chi_0 : [\chi_1, \dots, \chi_n]$, says that χ_1, \dots, χ_n are all subterms of χ_0 . Meta-variables establish the equality of subterms within an LRS description, within a larger TFL description (which may refer to the semantic term of more than one feature path's value), or across the scope of description variables in a single construct (such as sharing the semantics of the mother and head daughter of a phrase-structure rule). A subterm chain constrains a subterm from both ends: it must fall along the chain from V_{top} to V_{bottom} .

What descriptions do not need to explicate, crucially, are all of the well-formedness properties entailed by our interpretation of these description primitives. Mathematically, our models will already be limited to those that observe the necessary well-formedness properties, and computationally, LRS descriptions are closed under a fixed set of algebraic rules that enforce them, as given below. These rules can be extended, in fact, to allow for universally quantified implicational constraints over semantic terms, much as HPSG principles appear in TFL. The implication, $\backslash/S : \chi_S \longrightarrow \chi$, states that for every subterm S of the term being described, if S is described by χ_S , then the χ holds of the term described. In keeping with TRALE's interpretation of implicational constraints in TFL, the antecedents of these semantic implications are interpreted using subsumption rather than classical negation.

4.2 Description Language Integration

LRS descriptions are identified within ALE descriptions by their embedding within a `@lrs/1` macro that provides the necessary glue to CHR. As a simple example, consider the following expression of clause (1) of the LRS PROJECTION PRINCIPLE above in TRALE syntax:

```
phrase *> (daughters:hdtr:lf: @lrs([Alpha]),
           lf: @lrs([Alpha])).
```

The meta-variable `Alpha` is bound in the consequent of this universally quantified principle to both the *excont* of the head daughter and the *excont* of the mother, thus equating them. The square brackets are necessary because this *excont* must only be a subterm of the semantics of the head daughter and the semantics of the mother, and not necessarily identical.

The IContP above is expressed as:

```
sign *> lf: @lrs([E: [{I}]]).
```

The meta-variable `I` is identified as the *incont* of the sign's LF value by the curly braces of the *incont* binding primitive. This is a subterm (inner square brackets) of `E`, which is identified as its *excont* (caret), and as a subterm (outer square brackets) of its *sem* value. Unlike the TFL presentation, PARTS lists and other structural overhead are not required in our typed feature structures because meta-variables dually refer to both a term and the collection of all of its subterms.

4.3 CHR Implementation

In our Prolog implementation of LRS within the TRALE system, all LRS descriptions are compiled into constraints of a Constraint Handling Rules (CHR) handler, and their well-formedness properties are implemented as the constraint handling rules themselves. The primitive constraints they are compiled into are:

- `node(N, ArgTypes, ResType)`: node `N` has argument types `ArgTypes` with result type `ResType`.
- `literal(N, Lit, Arity)`: node `N` is labelled by literal `Lit` with arity `Arity`.
- `findom(N, Lits)`: node `N` is labelled by one of the literals in `Lits`.
- `ist(N, M, A)`: node `N` is the `A`th argument of node `M`.
- `st(N, M)`: node `N` is a subterm of node `M`.
- `excont(FS, N)`: the *excont* of feature structure `FS` is `N`.
- `incont(FS, N)`: the *incont* of feature structure `FS` is `N`.

- `contrib(FS, N)`: feature structure FS contributed N.
- `uniquecontrib(FS, N)`: feature structure FS uniquely contributed N.
- `nocontrib(FS, N)`: feature structure FS did not contribute N.

The nodes referred to here are nodes of the typed term graphs that represent the logical forms that we are assembling. In addition to these primitives, the transitive closure of `st/2`, called `ststar/2` is also computed on-line.

CHR rules consist of propagators (\implies) that detect the presence of a combination of constraints (left-hand side) in a global constraint store, and in that presence, execute Prolog goals (right-hand side) that typically add more constraints to the store. Detection, as in TRALE, amounts to suspending until subsumption holds. Simplification rules (\Leftrightarrow) additionally remove left-hand-side constraints designated by appearing to the right of the `\`. If no `\` is provided, then all left-hand-side constraints are removed. Right-hand-side goals can also be guarded (`|`) — if the guard fails, then the goal is not executed.

In CHR then, the following algebraic rules are used to enforce well-formedness:

- **literal/arity consistency**
 $\text{literal}(N, \text{Lit1}, \text{Arity1}) \setminus \text{literal}(N, \text{Lit2}, \text{Arity2})$
 $\Leftrightarrow \text{Lit1} = \text{Lit2}, \text{Arity1} = \text{Arity2}.$
- **literal extensionality**
 $\text{literal}(N, F, A), \text{literal}(M, F, A)$
 $\implies \text{ext_args}(A, N, M) \mid N=M.$
- **constants**
 $\text{literal}(N, _ , 0) \setminus \text{st}(M, N) \Leftrightarrow M = N.$
- **finite domains**
 $\text{findom}(N, \text{Lits}), \text{literal}(N, \text{Lit}, _)$
 $\implies \text{member}(\text{Lit}, \text{Lits}).$
- **immediate subterm irreflexivity**
 $\text{ist}(N, N, _) \implies \text{fail}.$
- **immediate subterm uniqueness**
 $\text{ist}(M1, N, A) \setminus \text{ist}(M2, N, A) \Leftrightarrow M1 = M2.$
- **subterm reflexivity**
 $\text{st}(N, N) \Leftrightarrow \text{true}.$
- **subterm idempotence**
 $\text{st}(M, N) \setminus \text{st}(M, N) \Leftrightarrow \text{true}.$
- **subterm subsumption**
 $\text{ist}(M, N, _) \setminus \text{st}(M, N) \Leftrightarrow \text{true}.$

- **subterm antisymmetry**
 $st(M, N), st(N, M) \Leftrightarrow M = N.$
- **subterm upward antisymmetry**
 $ist(M, N, _), st(N, M) \Leftrightarrow M = N.$
- **type consistency**
 $node(N, ATypes1, RType1) \setminus node(N, ATypes2, RType2)$
 $\Leftrightarrow RType1 = RType2, ATypes1 = ATypes2.$
- **literal well-typing**
 $node(N, ATypes, _ _), literal(N, _, A)$
 $\Rightarrow length(ATypes, A).$
- **immediate subterm well-typing**
 $node(M, _, MResType), node(N, NArgTypes, _), ist(M, N, A)$
 $\Rightarrow nth(A, NArgTypes, MResType).$
- **incont and excont functionhood**
 $incont(X, N) \setminus incont(X, M) \Leftrightarrow N=M.$
 $excont(X, N) \setminus excont(X, M) \Leftrightarrow N=M.$
- **unique contribution injectivity**
 $uniquecontrib(FS1, N) \setminus uniquecontrib(FS2, N)$
 $\Leftrightarrow FS1=FS2.$
- **unique contribution subsumption**
 $uniquecontrib(FS1, N) \setminus contrib(FS2, N) \Leftrightarrow FS1=FS2.$
- **negative contribution idempotence**
 $nocontrib(X, N) \setminus nocontrib(X, N) \Leftrightarrow true.$
- **negative contribution negativity**
 $nocontrib(FS, N), contrib(FS, N) \Leftrightarrow fail.$

`ext_args/3` is a guard that checks the arguments of `N` and `M` for equality.

This collection of rules is complete in the sense that any inconsistency that may exist with respect to our standard of well-formedness in `Ty2` will be detected. They are not complete in the sense that the result of simplification under these rules will be minimal in any useful sense, such as having a minimal number of distinct nodes in the resulting term graph, or a minimal number of (non-immediate) subterm arcs. The quest for a combination of propagators and search that would establish minimality efficiently (in practice, at least) remains to be pursued.

Turning to semantic implication, every instance of an implication description is compiled into its own CHR primitive constraint. This constraint occurs on the left-hand side of exactly one new propagator, which is charged with enforcing the implication. To require that universal quantifiers not outscope clausal boundaries, for example, we may require of clauses that:

```
\ /X:every (_, _, _) --> [ ^ [X] ] ) .
```

Let us call this implication instance *i*. We introduce a new primitive *i/1*, which will be applied to semantic terms for which implication *i* is asserted to hold. We then add one new propagator to enforce the implication:

```
i (LF) , ststar (X, LF) , literal (X, every, 3)  
==> node (Ex, _, _) , st (Ex, LF) , excont (FS, Ex) , st (X, Ex) .
```

Here, *LF* will be bound to the term to which *i* applies, *X*, to the universally quantified variable *X* stated in the implication source code, and *FS*, to the feature structure with which *LF* is the associated semantical term.

5 Conclusion

By separating linguistic representations and principles from structural well-formedness and computational considerations, we aspire to do a better job of both. This separation can be achieved by expanding the description language with a set of primitives that intuitively capture the requirements of semantical theories (LRS and otherwise) that manipulate logical forms as typed term graphs, not by using TFL at any aesthetic cost.

The extension presented here captures the basic primitives found in MRS and CLLS, the exceptions being the parallelism and anaphoric binding constraints primitively expressed by CLLS. Future empirical study is required before extending the language in this direction, in our opinion, because much of what falls under the rubrics of ellipsis and binding is not purely a semantic phenomenon.

A more interesting direction in which to extend the present work is towards a semantics which does not stop at logical form. Semantics involves meaning, and meaning is only distinguishable in the presence of inference. Although we have presented the semantic implication of our description language as a tool for conventional linguistic constraints or for perhaps extending a very common-sensical core of well-formedness conditions, they are equally well applicable to inference more broadly construed. This inference would be grounded in presuppositional content and shared background knowledge as much as it would be in the syntactic structure of typed lambda terms.

References

- Copestake, Ann, Flickinger, Dan, Pollard, Carl and Sag, Ivan A. 2003. Minimal Recursion Semantics: An Introduction. Journal submission, November 2003.
- Corblin, Francis and Tovenia, Lucia M. 2001. On the Multiple Expression of Negation in Romance. In Yves D'Hulst, Johan Rooryck and Jan Schroten (eds.), *Romance Languages and Linguistic Theory 1999*, pages 87–115, John Benjamins, Amsterdam.

- Egg, Markus and Erk, Katrin. 2002. A Compositional Account of VP Ellipsis. In Frank Van Eynde, Lars Hellan and Dorothee Beermann (eds.), *Proceedings of the 8th International Conference on Head-Driven Phrase Structure Grammar*, pages 162–179, Stanford: CSLI Publications.
- Egg, Markus, Koller, Alexander and Niehren, Joachim. 2001. The Constraint Language for Lambda Structures. *Journal of Logic, Language and Information* 10(4), 457–485.
- Frühwirth, T. and Abdennadher, S. 1997. *Constraint-Programmierung*. Springer.
- Gallin, Daniel. 1975. *Intensional and Higher-Order Modal Logic*. North-Holland, Amsterdam.
- Haegeman, Liliane and Zanuttini, Raffaella. 1991. Negative Heads and the Neg Criterion. *The Linguistic Review* 8, 233–251.
- Hendriks, Herman. 1993. *Studied Flexibility*. ILLC Dissertation Series 1995-5, Institute for Logic, Language and Computation, Amsterdam.
- Penn, G. 2004. Balancing Clarity and Efficiency in Typed Feature Logic through Delaying. In *Proceedings of the 40th Annual Meeting of the Association for Computational Linguistics*, pages 240–247.
- Richter, Frank. 2004. Foundations of Lexical Resource Semantics. Habilitation Thesis. Seminar für Sprachwissenschaft, Universität Tübingen.
- Richter, Frank and Sailer, Manfred. 2001. On the Left Periphery of German finite Sentences. In W. Detmar Meurers and Tibor Kiss (eds.), *Constraint-Based Approaches to Germanic Syntax*, pages 257–300, Stanford: CSLI Publications.
- Richter, Frank and Sailer, Manfred. 2004. Basic Concepts of Lexical Resource Semantics. In Arnold Beckmann and Norbert Preining (eds.), *European Summer School in Logic, Language and Information 2003 – Course Material I*, volume 5 of *Collegium Logicum*, pages 87–143, Kurt Gödel Society Wien.
- Sailer, Manfred. 2003. Combinatorial Semantics and Idiomatic Expressions in Head-Driven Phrase Structure Grammar. Phil. Dissertation (2000). Arbeitspapiere des SFB 340. 161, Eberhard-Karls-Universität Tübingen.
- Sailer, Manfred. 2004. Local Semantics in Head-Driven Phrase Structure Grammar. In Olivier Bonami and Patricia Cabredo Hofherr (eds.), *Empirical Issues in Syntax and Semantics*, volume 5, pages 197–214, URL: <http://www.cssp.cnrs.fr/eiss5/>.
- von Stechow, Arnim. 1993. Die Aufgaben der Syntax. In Joachim Jacobs, Arnim von Stechow, Wolfgang Sternefeld and Theo Vennemann (eds.), *Syntax. Ein internationales Handbuch zeitgenössischer Forschung*, volume 1, pages 1–88, Walter de Gruyter.

A compound matrix

Anders Søgaard 

Katholieke Universiteit Leuven

Proceedings of the 11th International Conference on
Head-Driven Phrase Structure Grammar

Center for Computational Linguistics, Katholieke Universiteit Leuven

Stefan Müller (Editor)

2004

Stanford, CA: CSLI Publications

pages 444–456

Søgaard, Anders. 2004. A compound matrix. In Stefan Müller (ed.), *Proceedings of the 11th International Conference on Head-Driven Phrase Structure Grammar*, Center for Computational Linguistics, Katholieke Universiteit Leuven, 444–456. Stanford, CA: CSLI Publications. DOI: 10.21248/hpsg.2004.25. 

Abstract

This paper presents a supplement to the Grammar Matrix, namely what I call a *Compound Matrix*; in reality, it is not a matrix, since the type file includes a fully specified cross-linguistic inventory of compound types. The idea is that the grammar writer can comment out the ungrammatical types for his or her own language. The theory behind the typology is presented here in a bottom-up fashion, from the basic assumptions to the actual linguistic types.

1 Assumptions

This study deals with the semantics of *two-constituent nonargumental compound nouns*, but it does not include discussion of the syntactic nature of compounds. For clarity of exposition, we adopted the most conventional analysis of such compound nouns; see Radford (1980) for some discussion:

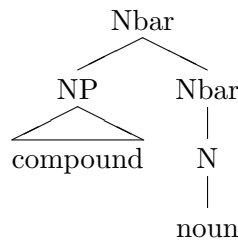

The inventory of the Compound Matrix is based on a typology. Two parameters were used for classifying compounds from about 30 different languages, namely:

- Each nominal constituent can refer in three ways: literally, metonymically or metaphorically. This property is called Reference.
- Independent of syntactic structure, each compound constituent is either the Pointer or Modifier of the construction, and this property is called Status.

The typological part of the study is documented in Søgaard (to appear (a)) and the properties are formally defined in Søgaard (2004). Reference is a Peircean-style trichotomy, while Status is a *functional* distinction; i.e. a Pointer “points” to the possible set of referents, whereas a Modifier modifies or restricts that set. The object of this paper is to provide a semantics for each of these constructions and to describe their implementation in the Compound Matrix. Two important assumptions relate to the translations of compound types:

- Qualia structure (Pustejovsky, 1991) with one additional quale for contour (Q_{ctr}) and Σ -roles (see below) were employed as vocabularies for talking about the meaning of compound nouns.

Table 1: The Compound Typology.

Type	Abbreviation	Example	Language
Appositional	[P(l)-P(l)]	<i>bahay-kubo</i> (house-hut; 'hut')	Tagalog
Copulative	[P(m ₁)-P(m ₁)]	<i>bassu karu</i> (bus-car; 'vehicles')	Kannada
Endocentric	[P(l)-M(m ₁)]	<i>oreh iton</i> (editor newspaper; 'newspaper editor')	Hebrew
Endocentric	[M(m ₁)-P(l)]	<i>numn numpran</i> (village-pig; 'domesticated pig')	Yimas
Endocentric	[P(l)-M(m ₂)]	<i>sundalong-kanin</i> (soldier-cooked rice; 'cowardly soldier')	Tagalog
Endocentric	[M(m ₂)-P(l)]	<i>mek'inobal</i> (mother-haze; 'rainbow')	Tzotzil
Exocentric	[P(m ₂)-M(m ₁)]	<i>panawag-pansin</i> (calling instr.-attention; 'one who wants attention')	Tagalog
Exocentric	[M(m ₁)-P(m ₂)]	<i>Romanteppich</i> (novel-tapestry; a style of prose)	German

- The translations were in (a sublanguage of) the Predicate Calculus.

This latter assumption was motivated by the wish to pass the grammar's output on to a model builder for disambiguation tasks; see Søgaard (2004) for documentation.

1.1 The Compound Typology

Logically, there are 36 possible combinations of Reference and Status. We call the compound whose left-constituent is a Modifier with metonymic Reference, and whose right-constituent is a Pointer with literal Reference, [M(m₁)-P(l)]. This corresponds to a run-of-the-mill endocentric compound in English, e.g. *lawn tennis*. Cross-linguistically, however, only 8 of these 36 types are found; see Table 1.¹

¹It is unclear whether compounds such as *hammerhead* ('shark') and *sabertooth* ('tiger') constitute a class of [M(m₂)-P(m₁)] compounds. No [P(m₁)-M(m₂)] compounds are yet attested. Or is *hammerhead* really a [M(m₂)-P(l)] compound the extension of which has been extended by metonymy? Is it suggestive that another name for sabertooths is *sabertoothed tigers*.

2 Σ -roles

The set of Σ -roles is defined as a (Parsons-style) vocabulary for talking about *event participants*. Since all agentive and telic qualia are eventive, compounds which get their meaning from these qualia involve Σ -roles. The collection of Σ -roles we employ, is inspired by Simon Dik's *Semantic Function Hierarchy* (here in a slightly revised version):

- (1) Agent[?] \gg Object[?] \gg (Recipient[?]) \gg (Beneficiary[?]) \gg Instrument* \gg Material* \gg Location*

(I put Recipient and Beneficiary in brackets, since these roles seem almost irrelevant in the semantics of compound nouns. Though see the appendix for a few exceptions.) For illustration, the telic quale of *knife* is $\lambda x.\exists e.\mathbf{cut}(e) \wedge \mathbf{knife}(x) \wedge \Sigma_{Instr}(x, e)$. If we want to say that a bread is the object of this event, we write $\lambda x.\exists e.\exists y.\mathbf{cut}(e) \wedge \mathbf{knife}(x) \wedge \Sigma_{Instr}(x, e) \wedge \mathbf{bread}(y) \wedge \Sigma_{Obj}(y, e)$. $\Sigma^?$ is optionally expressed, but only “once per event”. (No Sigma Criterion applies here.) Σ^* is optionally expressed more than once, and SIGMA-HEAD identifies the Σ -role of α in $\exists e.\Delta_\alpha(e)$. Consequently, the value of SIGMA-HEAD in **knife1** is **sigmainstr** (a subtype of **sigma-role**).

3 The Construction Hierarchy

The hierarchy of compound constructions, i.e. with the major [S(r)-S(r)]-types as supertypes, and the different combinations of qualia and Σ -roles as subtypes, already seems monstrous and unruly. Is this necessary? There are three reasons that I think the different vocabularies *are* necessary:

- If each construction is properly restricted, ambiguity is realistic, i.e. you typically get one to three readings for each compound.
- The different properties and inventories are helpful in the semantics of adjectives, genitives, prepositions, etc.
- There is empirical evidence for the grammaticality of the specific constructions.

4 Empirical Evidence

- $[M\langle m_1, \Sigma_{Agent} \rangle - P(1)]$ is ungrammatical in English, e.g. **butcher knife* and **musician guitar*; cf. Copestake and Lascarides (1997); but $[M\langle m_2 \rangle - P(1)]$ is not, e.g. *lady snow*²

²There are two possible constraints that explain the ungrammaticality of these examples. Either a certain construction ($[M\langle m_1, \Sigma_{Agent} \rangle - P(1)]$) is ungrammatical, or Attribute

Table 2: The Translation Algorithm.

Type	Logical form
[P(1)-P(1)]	$\lambda x.\beta'(x) \wedge \alpha'(x)$
[P(m ₁)-P(m ₁)]	$\lambda z.\exists x.\exists y.x \oplus y = z.\beta'(x) \wedge \alpha'(y)$ or $\lambda x.\Delta_{F_\beta}$
[P(1)-M(m ₁)]	$\lambda x.\alpha'(x) \wedge \forall y.\exists e.\Delta_\alpha(e) \wedge \Sigma_1(x, e) \wedge \Sigma_2(y, e) \rightarrow \beta'(y)$
[M(m ₁)-P(1)]	$\lambda x.\beta'(x) \wedge \forall y.\exists e.\Delta_\beta(e) \wedge \Sigma_1(x, e) \wedge \Sigma_2(y, e) \rightarrow \alpha'(y)$
[P(1)-M(m ₂)]	$\lambda x.\alpha'(x) \wedge \exists e.\Delta_\beta(e) \wedge \Sigma_1(x, e)$
[M(m ₂)-P(1)]	$\lambda x.\beta'(x) \wedge \exists e.\Delta_\alpha(e) \wedge \Sigma_1(x, e)$
[P(m ₂)-M(m ₁)]	$\lambda x.P(x) \wedge \forall z.\exists e.\Delta_\alpha(e) \wedge \Sigma_1(x, e) \wedge \Sigma_2(z, e) \rightarrow \beta'(z)$
[M(m ₁)-P(m ₂)]	$\lambda x.P(x) \wedge \forall z.\exists e.\Delta_\beta(e) \wedge \Sigma_1(x, e) \wedge \Sigma_2(z, e) \rightarrow \alpha'(z)$

- [M(m₁, Σ_{Instr})-P(1, Σ_{Agent})] is ungrammatical in Danish, e.g. **knivslagter* ('knife butcher') **guitar Musiker* ('guitar musician'); but [M(m₂)-P(1)] is not, e.g. *bildækmand* ('motor car tyre man'); neither is [M(m₁, Σ_{Instr})-P(1, Σ_{Instr_2})], e.g. *guitarforstærker* ('guitar amplifier')
- [M(m₁)-P(1)] where Δ is Contour, is ungrammatical in Estonian; cf. Hiramatsu et al. (2000)
- [M(m₁, Σ_{Loc})-P(1, Σ_{Instr})] translates consistently into β per α in Italian; cf. Paggio og Ørsnes (1993). There is also a grammatical distinction between telic- and agentive-based Δ -compounds; cf. Johnston and Busa (1999)
- ...

There is similar evidence for the grammaticality of non-endocentric constructions. For example, open copulative compounds exist in Modern Greek, but not in Germanic languages. Reportedly only endocentric constructions are found in West Greenlandic (Bauer, 2001).

5 A Translation Algorithm

In our Translation Algorithm (Table 2), *bread knife* translates: 'a bread such that if it cuts anything, then it's bread'. This is of course too restrictive. A better reading is 'a bread such that if it cuts anything, then it's *typically* bread'. This is captured by introducing a Γ -operator (Chierchia, 1995). The Γ -operator is not easy to evaluate computationally. Thus, we introduce an approximation: the $\geq \frac{1}{2}$ -quantifier, a Proportional Quantifier, which denotes a subset of $Mod(\phi)$; see Sogaard (to appear (b)).³

6 The Compound Matrix

The feature structure below represents the semantics of the compound *bread knife* at the \bar{N} -level in the Compound Matrix. It corresponds to the λ -formula above. The reading - 'a bread such that if it cuts anything, then it's bread' - is licensed by the fact that the formal qualia (type) of the non-head daughter unifies with the restriction on Σ_{Obj} of the telic quale of the head daughter.

nouns are restricted in their formal quale to be non-human. The predictions differ. Our first theory wrongly claim that *dog food* is ungrammatical, while the second theory wrongly claims that *child bed* is ungrammatical. Things seem to be fuzzy here. There is a tendency that $[M\langle m_1, \Sigma_{Agent} \rangle - P(1)]$ is not expressed in English, while the corresponding genitive is; on the other hand, $[M\langle m_1, \Sigma_{Obj} \rangle - P(1)]$ is expressed, even with animate or human modifiers. Consider the following examples: *dogtag*, *dog's tongue*, *dog Latin*, *dogwatch*.

³Another simplification is the translation of the exocentric compounds. In our translation, there is only room for one dependent type relation between α and β and the referent. Sometimes this is reasonable, as in the analysis of *dust bowl* ('anything which contains dust'), while in some cases there seem to be more than one relation; e.g. *iron horse* would be analyzed as 'anything made out of iron', which is obviously too unrestrictive. A better analysis would involve both agentive and telic qualia; namely 'anything made out of iron, which is used to transport human beings'. (In Danish, the equivalent of *iron horse*, i.e. *jernhest*, refers to both trains and bicycles.) Exocentric compounds are always underspecified (our analysis still allows plains and boats in $[[iron\ horse]]$). The exact reading of *iron horse* may be due to the historical origin of the word and its rapid lexicalization.

Also, the \forall -based analysis of endocentric compounds may be redundant in some cases. While a straight-forward \exists -analysis is far too weak for the non-deictic and non-lexicalized use of a compound like *salmon knife*, it suffices for the agentive reading of *Eskimo's knife* (which is a true compound in many Germanic languages). It seems foolish to say that an Eskimo's knife is a 'knife which, whenever (or, worse, at least half of the times) it is made, is made by Eskimos'.

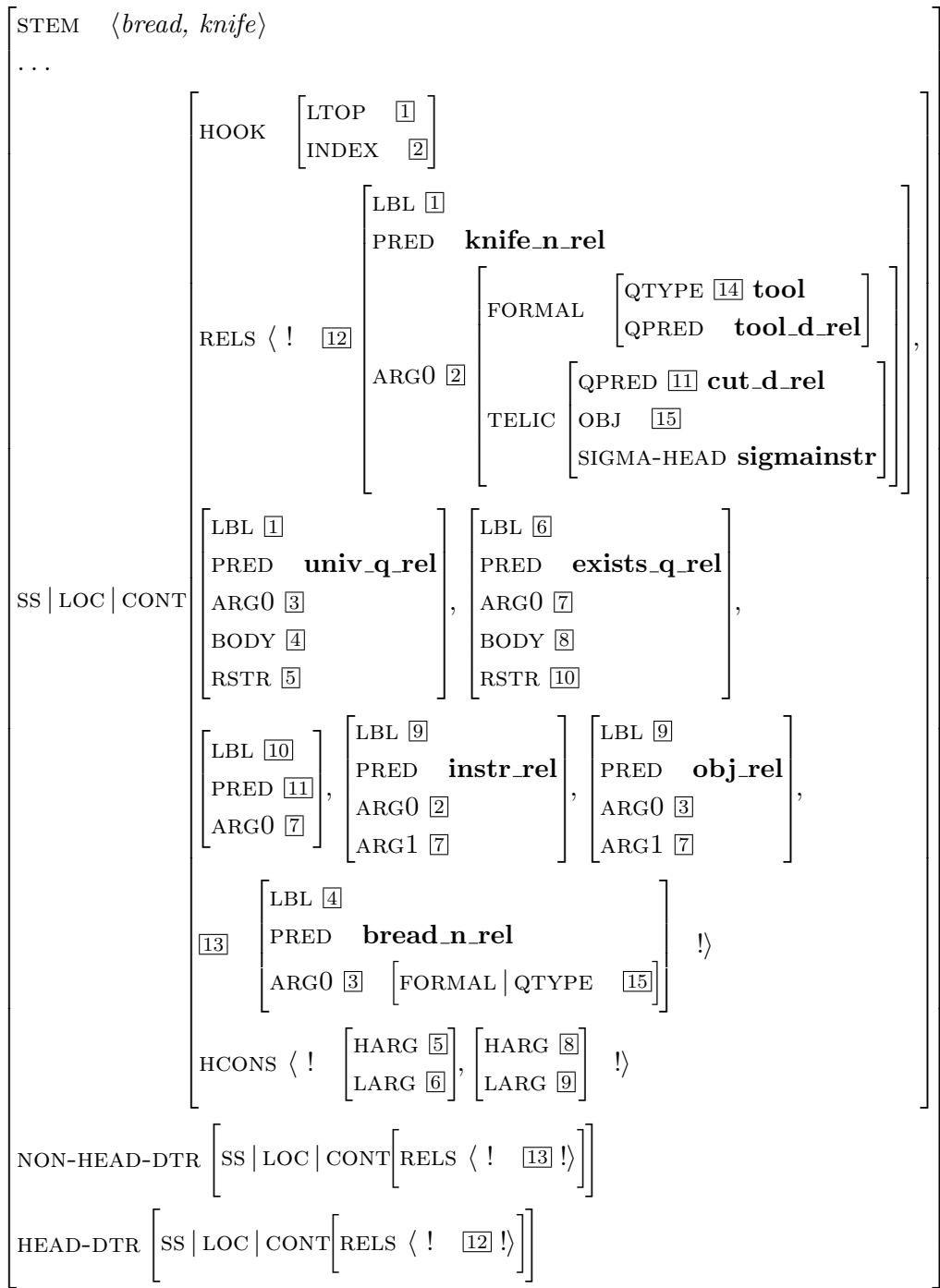

7 The Implementation of a Danish Compound Grammar

The Implementation Algorithm:

- extract qualia information from a SIMPLE dictionary (Lenci et al., 2000) - if there's one for your particular language, that is
- modify the matrix file
- comment out compound types which are ungrammatical in that language, and restrict the grammatical types with appropriate **semports**
- load the matrix file, the language specific grammar, and the "UG-ish" compound grammar

A simple Perl program was written for extraction. Not all relevant information (i.e. Contour and SIGMAHEAD) are contained in the SIMPLE dictionaries, so we restricted the Perl output in various ways:⁴

- `bil1 := nom-lxm & [STEM <"bil">,SYNSEM.LOCAL.CONT [HOOK.INDEX [FORMAL [QTYPE vehicle, QPRED "vehicle.d.rel"], AGENTIVE [QPRED "fremstille.cre.d.rel", SIGMAHEAD sigmaagentive], TELIC [QPRED "transportere.d.rel", SIGMAHEAD sigmarole], CONTOUR [QTYPE contoursort, QPRED "bil-shaped.d.rel"]], RELS <![PRED ".bil.n.rel"!>]]].`
- `bil1 := nom-lxm & [STEM <"bil">,SYNSEM.LOCAL.CONT [HOOK.INDEX [FORMAL [QTYPE vehicle, QPRED "vehicle.d.rel"], AGENTIVE [QPRED "fremstille.cre.d.rel", SIGMAHEAD sigmaagentive], TELIC [QPRED "transportere.d.rel", SIGMAHEAD sigmainstr], CONTOUR [QTYPE cubic, QPRED "bil-shaped.d.rel"]], RELS <![PRED ".bil.n.rel"!>]]].`

The necessary modifications of the matrix file are:

- remove the constraint that quantifiers only quantify over **ref-ind**, i.e. include events
- add a **semport** ontology (e.g. one based on the SIMPLE dictionary) and a **contoursort** ontology
- add types for qualia

8 Interpretation hierarchy

(Parallels complexity in processing, i.e. economy.)

- Words, i.e. lexicalized compounds

⁴For those who don't speak Danish: `bil` is *car*, `fremstille` is *manufacture*, and `transportere` is *transport*.

- Endocentric compounds (incl. appositional and copulative compounds; is there any internal ranking?)
- Exocentric compounds
- Pragmatic interpretations (incl. deictic compounds?)

9 Differences between Danish and English

Using the Compound Matrix types, we constructed a Danish Compound Grammar, following the algorithm above. The grammar is about 2000 words and it blocks 4 types out of about 70 compound constructions. We also constructed an English test grammar; see Søgaard (2004). One of the immediate advantages of compatible grammars is that one can easily describe the differences between compound components of different grammars. Some of the major differences between Danish and English are mentioned here:

- $[M\langle m_1, \Sigma_{Instr} \rangle - P\langle l, \Sigma_{Agent} \rangle]$ is blocked in Danish
- $[M\langle m_1, \Sigma_{Agent} \rangle - P(l)]$ is blocked in English
- While $[P(l) - M(m_1)]$ works in the domain of law in English (e.g., *Code Napoleon*), it doesn't in Danish
- ...

10 Conclusion and Applications

The Grammar Matrix as such adopts a pragmatic approach to compound semantics (Flickinger and Bender, 2003). Such an approach is theoretically inadequate for a variety of reasons. This is evidenced by some of the data presented here, i.e. the ungrammaticality of certain compound types in certain languages, but see Liberman and Sproat (1992), Copestake and Lascarides (1997) and Søgaard (2004) for some more detailed discussion. The supplement presented here addresses this problem in the current design of the Grammar Matrix. The supplement provides exactly the kind of analyses which are necessary for applications such as machine translation and knowledge-based disambiguation.

The Compound Matrix is a flexible module that could easily be fit into other packages, e.g. ERG or the Matrix of Mainland Scandinavian which is currently being developed by the Scandinavian HPSG community. Since semantics is first-order axiomatizable, knowledge-based disambiguation is possible with theorem provers and model builders; cf. Søgaard (2004). The Compound Matrix is for now available upon request.

11 Appendix 1: Σ -roles in $[M(m_1)-P(l)]$ compounds

Where $\alpha = Agent$:

- (2) (a) eskimomusik ('Eskimo's music') ($\beta = Object$)
- (b) eskimokniv ('Eskimo's knife') ($\beta = Instrument$)
- (c) kunstnerværksted ('artists' workplace') ($\beta = Location$)
- (d) børneler ('children's clay') ($\beta = Material$)

Where $\alpha = Object$:

- (3) (a) romanforfatter ('novel writer') ($\beta = Agent$)
- (b) tomatkniv ('tomato knife') ($\beta = Instrument$)
- (c) grøntsagstorv ('vegetable marketplace') ($\beta = Location$)
- (d) skulpturler ('sculpture clay') ($\beta = Material$)

Where $\alpha = Recipient$ or *Beneficiary* (seldom):

- (4) (a) børneforfatter ('children's writer') ($\beta = Agent$)
- (b) kirkeskat ('church tax') ($\beta = Object$)
- (c) børnepenge (children-money; 'financial support to parents')
($\beta = Object$)
- (d) næsedråber ('nose drops') ($\beta = Instrument$)

Where $\alpha = Instrument$:

- (5) (a) * ($\beta = Agent$)
- (b) sværddans ('sword dance') ($\beta = Object$)
- (c) elsav ('power saw') ($\beta = Instrument$)
- (d) knivkøkken ('knife kitchen') ($\beta = Location$)
- (e) støbeformsjern ('mold/cast iron') ($\beta = Material$)

Where $\alpha = Location$:

- (6) (a) koncertmusiker ('concert musician') ($\beta = Agent$)
- (b) skolemad ('school food') ($\beta = Object$)
- (c) køkkenkniv ('kitchen knife') ($\beta = Instrument$)
- (d) skolebod ('school booth/shop') ($\beta = Location$)
- (e) skoleler ('school clay') ($\beta = Material$)

Where $\alpha = Material$:

- (7) (a) stålsmed ('steel smith') ($\beta = Agent$)
- (b) oliemaleri ('oil painting') ($\beta = Object$)
- (c) ?boghvedeovn ('buckwheat oven') ($\beta = Instrument$)
- (d) træværksted ('wood workshop') ($\beta = Location$)

12 Appendix 2: Σ -roles in $[M(m_1)-P(m_2)]$ compounds

Where $\alpha = Agent$:

- (8) (a) børnechampagne (children's champagne; 'juice') ($\beta = Object$)
- (b) hundeskål ('dogs' bowl') ($\beta = Instrument$)
- (c) hundehus ('dogs' house') ($\beta = Location$)
- (d) hippietobak (hippies' tobacco; marihuana) ($\beta = Material$)

Where $\alpha = Object$:

- (9) (a) fodbolddommer (football judge; 'referee') ($\beta = Agent$)
- (b) fiskelomme (fish pocket; 'place with many fish') ($\beta = Instrument$)
- (c) auraværksted (aura workshop/repair office; 'psychologists' office') ($\beta = Location$)
- (d) fjeldhyttebeton (Norwegian cabin beton/concrete; 'wood') ($\beta = Material$)

Where $\alpha = Instrument$:

- (10) (a) * ($\beta = Agent$)
- (b) bogstavrim (letter rhyme; alliteration) ($\beta = Object$)
- (c) flaskepost (bottle mail; 'bottle message') ($\beta = Instrument$)
- (d) vindmølle ('wind mill') ($\beta = Location$)
- (e) printer lead ('ink, cartridge') ($\beta = Material$)

Where $\alpha = Location$:

- (11) (a) køkkenmusiker ('kitchen musician') ($\beta = Agent$)
- (b) bordtennis ('table tennis') ($\beta = Object$)
- (c) rumskib ('space ship') ($\beta = Instrument$)
- (d) kloakrestaurant (underground restaurant; 'foot chamber for rats') ($\beta = Location$)
- (e) Grønlandsmursten (Greenland brick; 'ice block (for iglos)') ($\beta = Material$)

Where $\alpha = Material$:

- (12) (a) betontømrer ('beton carpenter') ($\beta = Agent$)

- (b) lufttennis ('air tennis') ($\beta = \textit{Object}$)
- (c) luftguitar ('air guitar') ($\beta = \textit{Instrument}$)
- (d) genværksted ('genetics repair office') ($\beta = \textit{Location}$)

I realize that *fodboldommer* and *vindmølle* could also be analyzed as endocentric compounds, accepting very underspecified lexical semantics of *ommer* and *mølle*. These examples are just for illustration, so this problem is ignored. There are plenty of examples in both these categories, e.g., respectively, *bogorm* ('bookworm') and *cykelmotorvej* (bicycle highway; 'broad path for bicycles').

13 References

- Bauer, Laurie. 2001. Compounds. In Martin Haspelmath et al. (eds.), *Language typology and language universals*. Berlin: de Gruyter.
- Chierchia, Gennaro. 1995. Individual-level predicates as inherent generics. In Gregory Carlson and Francis Pelletier (eds.), *The generic book*. Chicago: University of Chicago Press.
- Copestake, Ann; Lascarides, Alex. 1997. Integrating symbolic and statistical representations: the lexicon-pragmatics interface. *Proceedings of ACL-EACL 1997*. Madrid, Spain.
- Hiramatsu, Kazuko; Snyder, William; Roeper, Thomas; Storrs, Stephanie; Saccomoni, Mathew. 2000. On musical hand chairs and linguistic swing. *Proceedings of the 24th Boston University Conference on Language Development*. Somerville, USA.
- Johnston, Michael; Busa, Federica. 1999. Qualia structure and the compositional interpretation of compounds. In Evelyne Viegas (ed.), *Breadth and depth of semantic lexicons*. Dordrecht: Kluwer.
- Lenci, Alessandro; Busa, Federica; Ruimy, Nilda; Gola, Elisabetta; Monacchini, Monica; Galzolari, Nicoletta; Zampolli, Antonio; Guimier, Emilie; Recourcé, Gaëlle; Humphreys, Lee; von Rekovsky, Ursula; Ogonowski, Antoine; McGauley, Clare; Peters, Wim; Peters, Ivonne; Gaizauskas, Robert; Villegas, Marta. 2000. *Linguistic specifications*. SIMPLE Work Package 2.
- Lieberman, Mark; Sproat, Richard. 1992. The stress and structure of modified noun phrases in English. In Anna Szabolcsi and Ivan Sag (ed.), *Lexical matters*. Stanford: CSLI.
- Paggio, Patrizia; Ørnsnes, Bjarne. 1993. Automatic translation of nominal compounds. *Rivista di Linguistica* 5: 129-156.
- Pustejovsky, James. 1991. The generative lexicon. *Computational Linguistics* 17: 409-441.
- Radford, Andrew. 1980. *Transformational grammar*. Cambridge: Cambridge University Press.
- Søgaard, Anders. (2004). *Compound semantics: interpretation, representation and implementation*. Copenhagen: Dpt. of Computational Linguistics, Copenhagen Business School. (MA-thesis)
- Søgaard, Anders. (to appear (a)). Compounding theories and linguistic diversity. In Zygmunt Frajzyngier (ed.), *Language theories and linguistic diversity*. Amsterdam: John Benjamins.
- Søgaard, Anders. (to appear (b)). Proportional quantifiers in first-order logic. Submitted to the Workshop on Computational Semantics 2005.