

**Proceedings of the 20th International Conference on  
Head-Driven Phrase Structure Grammar**

Freie Universität Berlin

Stefan Müller (Editor)

2013

Stanford, CA: CSLI Publications

The papers are published under a CC-BY license:  
<http://creativecommons.org/licenses/by/4.0/>

## Contents

Editor's note	3
<b>I Contributions to the Main Conference</b>	<b>4</b>
Mansour Alotaibi, Robert D. Borsley: Gaps and resumptive pronouns in Modern Standard Arabic	6
Olivier Bonami, Berthold Crysmann: Morphotactics in an information-based model of realisational morphology	27
Michael Hahn: Word order variation in Khoekhoe	48
Petter Haugereid, Nurit Melnik, Shuly Wintner: Nonverbal predicates in Modern Hebrew	69
Anke Holler: Reanalyzing German correlative <i>es</i>	90
Dawei Jin: Information structure constraints and complex NP islands in Chinese	110
Philip Miller: Usage preferences: The case of the English verbal anaphor <i>do so</i>	121
Stefan Müller, Bjarne Ørsnes: Passive in Danish, English, and German	140
Adam Przepiórkowski: The syntax of distance distributivity in Polish: Preserving generalisations with weak heads	161
Byong-Rae Ryu: Multiple case marking as case copying: A unified approach to multiple nominative and accusative constructions in Korean	182
Tibor Szécsényi: Argument inheritance and left periphery in Hungarian infinitival constructions	203
Frank Van Eynde, Liesbeth Augustinus: Why and how to differentiate complement raising from subject raising in Dutch	222
<b>II Contributions to the Workshop</b>	<b>243</b>
Artemis Alexiadou: Where is non-active morphology?	244
Peter W. Culicover: Simpler Syntax and explanation	263

## Editor's note

The 20th International Conference on Head-Driven Phrase Structure Grammar (2013) was held at the Freie Universität Berlin.

The conference featured 2 invited talks and 15 papers selected by the program committee (Emily M. Bender, Olivier Bonami, Bob Borsley, Rui Chaves, Berthold Crysmann, Kordula De Kuthy, Elisabet Engdahl, Daniel Flickinger, Jong-Bok Kim, Jean-Pierre Koenig, Valia Kordoni, Anna Kupsc, Robert Levine, Nurit Melnik, Stefan Müller, Tsuneko Nakazawa, Gerald Penn, Adam Przepiórkowski, Frank Richter, Louisa Sadler, Ivan Sag, Manfred Sailer, Jesse Tseng (chair), Frank Van Eynde, Gert Webelhuth, Stephen Wechsler, Shuichi Yatabe, Eun-Jung Yoo).

A tutorial *Linguistic Research with Large Annotated Web Corpora* by Felix Bildhauer and Roland Schäfer and a workshop about *Progress in Linguistics* were attached to the conference. The workshop program was put together by Stefan Müller and consisted of invited talks only.

We want to thank the respective program committees for putting this nice program together.

Thanks go to Stefan Müller (chair), Viola Auermann, Lea Helmers, and Jakob Maché, who were in charge of local arrangements.

The conference was supported by a grant from the Deutsche Forschungsgemeinschaft to Stefan Müller (MU 2822/7-1).

As in the past years the contributions to the conference proceedings are based on the five page abstract that was reviewed by the respective program committees, but there is no additional reviewing of the longer contribution to the proceedings. To ensure easy access and fast publication we have chosen an electronic format.

The proceedings include all the papers except those by Farell Ackerman, Rob Malouf, and John Moore, Tibor Kiss, Takafumi Maekawa, Gereon Müller, Stefan Müller (workshop), Andreas Pankau, Frank Richter, Anatol Stefanowitsch, and Nigel Vincent.

**Part I**

**Contributions to the Main Conference**

# Gaps and resumptive pronouns in Modern Standard Arabic

Mansour Alotaibi

University of Essex, Salman bin Abdulaziz University

Robert D. Borsley 

University of Essex

Proceedings of the 20th International Conference on  
Head-Driven Phrase Structure Grammar

Freie Universität Berlin

Stefan Müller (Editor)

2013

Stanford, CA: CSLI Publications

pages 6–26

Alotaibi, Mansour & Robert D. Borsley. 2013. Gaps and resumptive pronouns in Modern Standard Arabic. In Stefan Müller (ed.), *Proceedings of the 20th International Conference on Head-Driven Phrase Structure Grammar, Freie Universität Berlin*, 6–26. Stanford, CA: CSLI Publications. DOI: 10.21248/hpsg.2013.1.



## Abstract

Unbounded dependencies in Modern Standard Arabic often involve not a gap but a null resumptive pronoun. The facts are quite complex, but it is not too difficult to extend the SLASH mechanism of HPSG to handle dependencies with a null resumptive pronoun. It is also not too difficult to restrict the distribution of gaps appropriately.

### 1. Introduction

Unlike English but like many other languages, Modern Standard Arabic (MSA) has unbounded dependencies which sometimes involve a gap and sometimes involve a resumptive pronoun. The facts are quite complex, but we will show in this paper that it is not too difficult to provide an analysis within HPSG.

The paper is organized as follows. In section 2, we set out the basic data and show that MSA has gaps in some positions and phonologically empty resumptive pronouns in others. Then, in section 3 we outline an HPSG analysis of the data in which both gaps and empty resumptive pronouns are realizations of SLASH. In section 4, we look more closely at some important coordination data, and in section 5, we discuss the analysis of subordinate clauses introduced by the complementizer *ʔanna*. Finally, in section 6, we summarize the paper.

### 2. The data

Like most languages MSA, does not allow a gap in prepositional object position. However, it allows a resumptive clitic in this position. We have the following contrast:

- (1) a. \*ʔayy-i      dʒaamiʕat-in      ɖahaba      Aħmad-u      ʔila \_\_\_\_?  
          which-GEN    university-GEN    went.3SM    Ahmad-NOM    to  
          ‘Which university did Ahmad go to?’  
      b. ʔayy-u      dʒaamiʕat-in      ɖahaba      Aħmad-u      ʔilai-**ha**?  
          which-NOM    university-GEN    went.3SM    Ahmad-NOM    to-it

---

↑ We are grateful to the reviewers and audience at the 20th HPSG conference in Berlin for their helpful comments and discussion. We alone are responsible for what appears here.

Here and subsequently we mark gaps by ‘ \_\_\_ ’ and place resumptive clitics in bold. (We will argue later, however, that certain apparent gaps are really null resumptive pronouns.) Not surprisingly, it is possible to express the same meaning with a PP filler:

- (2) [<sub>PP</sub> ?ila ?ayy-i      dʒaamiʕat-in]      ðahaba      Ahmad-u      \_\_\_?  
to which-GEN      university-GEN      went.3SM      Ahmad-NOM  
‘To which university did Ahmad go?’

Possessor position is similar. Here too a gap is impossible, but a resumptive clitic is fine:

- (3) a. \*?ayy-i      muʔallif-in      garaʔa      Ahmad-u      kitaab-a \_\_\_?  
which-GEN      author-GEN      read.3SM      Ahmad-NOM      book-ACC  
‘Which author’s book has Ahmad read?’  
b. ?ayy-u      muʔallif-in      garaʔa      Ahmad-u      kitaab-a-**hu**?  
which-NOM      author-GEN      read.3SM      Ahmad-NOM      book-ACC-his

It is also possible to express this meaning with a complex NP containing a possessor as a filler:

- (4) [<sub>NP</sub> kitaab-a      ?ayy-i      muʔallif-in]      qaraʔa      \_\_\_      Ahmad-u?  
book-ACC      which-GEN      author-GEN      read.3SM      Ahmad-NOM  
‘Which author’s book has Ahmad read?’

Following Miller and Sag (1997), we assume that MSA clitics are affixes realizing an otherwise unexpressed argument, and not just the result of some superficial cliticization process. We will call such arguments *pro* because we assume that the same element is the subject argument in a null subject sentence.<sup>1</sup> On this view, it is strictly speaking the *pro* that is the resumptive element. The prepositional object and possessor positions both bear genitive case, as (2) and (4) show. However, the filler in (1b) and (3b) is nominative. We will see that a filler associated with a resumptive clitic is always nominative.

Turning to object position, we find that it allows either a gap or a resumptive clitic in *wh*-questions:

- (5) a. ?ayy-a      T-tullaab-i      qaabala      l-qaʔid-u      \_\_\_?  
which-ACC      the-students-GEN      met.3SM      the-leader-NOM  
‘Which of the students has the leader met?’  
b. ?ayy-u      T-tullaab-i      qaabala-**hum**      l-qaʔid-u?  
which-NOM      the-students-GEN      met.3SM-them      the-leader-NOM

<sup>1</sup> For Miller and Sag, the arguments associated with clitics are of type *aff*. However, they are dealing with French, a language which does not have null subject sentences.

The filler is accusative with a gap (as one would expect) and nominative with a resumptive clitic. Notice that the clitic in (5b) is not adjacent to the object position. This argues that it is not the result of a superficial cliticization process. We have the same two possibilities in relative clauses with a definite antecedent, as the following, from Alqurashi and Borsley (2012), show:

- (6) a. qaabaltu r-rajul-a [llaðii ʔarifu \_\_\_\_]  
 met.1SM the-man-ACC that knew.1SM  
 ‘I met the man that I knew.’  
 b. qaabaltu r-rajul-a [llaðii ʔarifu-**hu**]  
 met.1SM the-man-ACC that knew.1SM-him  
 ‘I met the man that I knew.’

In contrast, relatives with an indefinite antecedent only allow a resumptive clitic when object position is relativized:

- (7) a. \*qaabaltu rajul-an [ʔaʕrifu \_\_\_\_]?  
 met.1SM man-ACC knew.1SM  
 ‘I met a man that I knew’  
 b. qaabaltu rajul-an [ʔaʕrifu-**hu**]?  
 met.1SM man-ACC knew.1SM-him

Notice that there is no filler in these clauses.

Next we consider subject position. It has often been assumed that MSA has both postverbal and preverbal subjects (Mohammad 2000) and that they differ with respect to agreement, the former triggering only person and gender agreement and the latter triggering number agreement as well. The following illustrate:

- (8) qaabala/ \*qaabaluu T-tullaab-u Ahmad-a  
 met.3SM met.3PM the-students-NOM Ahmad-ACC  
 ‘The students met Ahmad’  
 (9) T-tullaab-u qaabaluu / \*qaabala Ahmad-a  
 the-students-NOM met.3PM met.3SM Ahmad-ACC  
 ‘The students met Ahmad’

However, what are often viewed as preverbal subjects are required to be definite (Fassi Fehri 1993):

- (10) l-ʔawlaad-u jaaʔuu  
 the-children-NOM came.3PM  
 ‘The children came’



- (11) \*ʔawlaad-un jaaʔuu  
 children-NOM came.3PM  
 ‘Children came’

This suggests that they are really topics associated with a null subject of some kind, and hence that the only real subjects are post-verbal (Aoun *et al* 2010). Assuming this is right, we need to ask why we have full agreement in examples like (9). One would expect a gap to have the same properties as the associated filler and to trigger agreement in the same way. This suggests that the null subject is not a gap but a resumptive *pro*. There is evidence that a *pro* subject triggers full agreement. Consider the following null subject sentences:

- (12) a. laqad qaabala Ahmad-a  
 indeed met.3SM Ahmad-ACC  
 ‘He met Ahmad.’  
 b. laqad qaabaluu Ahmad-a  
 indeed met.3PM Ahmad-ACC  
 ‘They met Ahmad.’

These can only have the meanings indicated. Assuming that they have a *pro* subject, this means that we have full agreement with a *pro* subject. Hence, if we assume that (9) also has a *pro* subject, we expect full agreement. It looks, then, as if only a resumptive *pro* and not a gap is possible in subject position.

Not surprisingly, sentences where a topic is understood as the subject of a subordinate clause point to the same conclusion. Consider the following:

- (13) T-tullaab-u ʔiq tarahtu [ʔan yušaarikuu/  
 the-students-NOM suggested.1SM that participate.3PM  
 \*yušaarika fii l-musaabaqat-i]  
 participate.3SM in the-competition-GEN  
 ‘The students I suggested participate in the competition.’

Here, as in (9), the verb shows full agreement. This suggests that we also have *pro* as the subject of the subordinate clause.

Sentences with an initial *wh*-phrase are like sentences with an initial topic. Parallel to (9), we have the following:

- (14) ʔayy-u Tullaab-in ʔaraf-uu / \*ʔarafa  
 which-NOM students-GEN knew.3PM knew.3SM  
 l-ʔijaabat-a?  
 the-answer-ACC  
 ‘Which students knew the answer?’

As in (9), we have full agreement, suggesting the subject is a *pro*. Parallel to

(13), we have (15).

- (15) ʔayy-u      Tullaab-in      qarrarta      [ʔan    usaafiruu /  
 which-NOM    students-GEN    decided.2SM    that    travel.3PM  
 \*usaafira    ʔla Roma]?  
 travel.3SM    to Rome  
 ‘Which of the students have you decided should travel to Rome?’

Once more, we have full agreement, suggesting we have a pro subject.

As one would expect, MSA also has certain non-nominal gaps. Firstly, there are PP gaps with verbs:

- (16) ʔila ʔayy-i      dʒaamiʕat-in      ḏahaba      Aliy-un      \_\_\_?  
 to    which-GEN    university-GEN    went.3SM    Ali-NOM  
 ‘To which university did Ali go?’

Secondly, there are PP gaps with adjectives:

- (17) min    maḏaa kaana    Aḥmad-u      khaaʔif-an      \_\_\_?  
 from    what    was    Aḥmad-NOM    afraid-ACC  
 ‘Of what was Ahmad afraid?’

Finally, there are adverbial gaps:

- (18) mataa ḏahaba    Aliy-un    ʔil    al-dʒaamiʕat-i      \_\_\_?  
 when    went.3SM    Ali-NOM    to    the-university-GEN  
 ‘When did Ali go to the university?’

The facts that we have set out above are quite complex. We can summarize them as follows:

	Gap	Pro
Subject	No	Yes
Object	In some constructions	Yes
Prepositional object	No	Yes
Possessor	No	Yes
PP complement of verb	Yes	No
PP complement of adjective	Yes	No
Adverbial	Yes	No

Table 1: The distribution of gaps and resumptive pros in MSA

The one position in which things are complex is object position, which allows a gap in *wh*-questions, and definite relatives, but not in indefinite

relatives. We will see in section 5 there is another construction which doesn't allow a gap in object position.

It has been widely assumed since Keenan and Comrie (1977) that subject position is more accessible than object position so that if a gap is possible in the latter it is also possible in the former. However, it is not really clear that this is right. In English, a gap is possible in object position, but as Koopman (1983) noted, the unacceptability of examples like the following suggests that a gap is not possible in subject position in an auxiliary-initial clause:

(19) \*Who did see Lee?

Of course, this is acceptable if *did* is stressed, as in (20).

(20) Who DID see Lee?

But this a *wh*-question counterpart of a subject-initial clause with either a preverbal gap (Levine and Hukari 2006) or no gap at all (Ginzburg and Sag 2000). Thus, the impossibility of a gap in object position in Arabic is perhaps not so surprising.

### 3. An HPSG analysis

An analysis of the data we have set out above needs to do two things: (a) to incorporate resumptive *pro* into an account of unbounded dependencies, and (b) to restrict the distribution of gaps. We will discuss both of these matters in the following pages.

Following Levine and Hukari (2006), we assume that the null hypothesis is that all unbounded dependencies involve the same mechanism, within HPSG the SLASH mechanism. However, it is widely assumed that differences between gaps and resumptives with respect to island constraints suggest that they involve different mechanisms. Consider the following examples:

- (21)a, \*[ʔayy-a bint-in] raʔaita [l-ʔasad-a [llaðii ʔakala  
 which-ACC girl-GEN saw.2SM the-lion-ACC that ate.3SM  
 \_\_\_\_\_]]  
 ‘Which girl did you see the lion that ate?’
- b. [ʔayy-u bint-in] raʔaita [l-ʔasad-a [llaðii  
 which-NOM girl-GEN saw.2SM the-lion-ACC that  
 ʔakala-**ha**]]  
 ate.3SM-her  
 ‘Which girl did you see the lion that ate?’

In these examples the *wh*-phrase in initial position is associated with object

position inside a relative clause. In (21a) there is a gap in object position and it is unacceptable. In (21b) there is a resumptive in object position and it is acceptable. Within transformational work, e.g. Aoun *et al.* (2010), contrasts like these have been seen as evidence that there is movement with a gap but no movement with a resumptive.<sup>2</sup> However, as Borsley (2010, 2013) notes in connection with Welsh, such contrasts only argue for a significant grammatical difference between gaps and resumptives if islands are a grammatical matter. It has been argued e.g. by Kluender (1998), Levine and Hukari (2006), Hofmeister and Sag (2010), and Hofmeister, Staum Casasanto, and Sag (in press) that they are a processing matter. If this is right, contrasts like that in (21) do not necessitate differences in syntactic analysis.

In MSA, as in some other languages, there is evidence from coordination that resumptive pros involve the same SLASH mechanism as gaps. It has been well known since Ross (1967) that unbounded dependencies are subject to the Coordinate Structure Constraint, which essentially says that an unbounded dependency may not affect one conjunct of a coordinate structure unless it affects the other(s), in which case it is commonly referred to as an across-the-board dependency.<sup>3</sup> In the case of MSA, it rules out (22) while allowing (23).

- (22) \*man [tuhibu \_\_\_ wa tušadžiʔu Aħmad-a fii  
 who like.2SM and support.2SM Ahmad-ACC in  
 nafs-i l-waqt-iʔ]  
 same-GEN the-time-GEN  
 \*‘Who do you like and support Ahmad at the same time?’
- (23) man [tuhibu \_\_\_ wa tušadžiu \_\_\_ fii nafs-i  
 who like.2SM and support.2SM in same-GEN  
 l-waqt-iʔ]  
 the-time-GEN  
 ‘Who do you like and support at the same time?’

(23) has a gap in both clauses. Consider now the following:

---

<sup>2</sup> Aoun *et al.* (2010) in fact assume that there may be movement with a resumptive but that there need not be.

<sup>3</sup> Work by Goldsmith (1985), Lakoff (1986), and Kehler (2002) has shown that the Constraint only applies when the conjuncts are parallel in certain ways. However, this is not particularly important in the present context.

- (24) man [tuhibu \_\_\_wa tušadzi<sup>ʕ</sup>u-**hu** fii nafs-i  
 who like.2<sub>SM</sub> and support.2<sub>SM</sub>-him in same-GEN  
 l-waqt-i<sup>ʕ</sup>]  
 the-time-GEN  
 ‘Who do you like and support at the same time?’

This example has a gap in the first clause and a resumptive clitic in the second. As Alqurashi and Borsley (2012) note, we have similar examples in relative clauses such as that in (25).

- (25) l-fataatu [llati ʔuhibbu \_\_\_ wa ʔahrasu ʕalay-**ha**]  
 the-girl.NOM that.SF love.1<sub>SM</sub> and care.1<sub>SM</sub> about-her  
 ‘the girl that I love and care about’

It seems, then, that gaps and resumptive pros have the same status as far as the Coordinate Structure Constraint is concerned. This is unsurprising if both are realizations of SLASH but is a major complication if resumptives involve a different feature as in Vaillette (2000, 2002). A similar argument is developed on the basis of Hausa in Crysmann (2012).

If resumptive pros are realizations of SLASH, one might propose that they have a feature makeup rather like that of gaps. Specifically, one might propose the following:

- (26)
- $$\left[ \begin{array}{l} \text{LOCAL}[1]\text{NP}: \textit{pro} \\ \text{SLASH}\{[1]\} \end{array} \right]$$

This, however, would require fillers to be pronominal, which of course they need not be. It would also require fillers to have the same case as the pro. As we have seen, a filler associated with pro is always nominative even when pro is in a genitive or accusative position. More plausible is the following:

- (27)
- $$\left[ \begin{array}{l} \text{LOCAL NP}: \textit{pro} [\text{INDEX}[1]] \\ \text{SLASH}\{\text{NP}: [\text{INDEX}[1]]\} \end{array} \right]$$

Here the value of LOCAL and the local feature structure within SLASH are only coindexed. Hence, fillers will not be required to be pronominal or to have the same case as the pro. However, there is an important objection to such an analysis.

A central fact about resumptive pros is that they appear in the same positions as non-resumptive pros – subject position and positions associated with a clitic. (12a), repeated here as (28), and (29)–(31) illustrate:

- (28) laqad qaabala Ahmad-a  
indeed met.3SM Ahmad-ACC  
'He met Ahmad.'
- (29) qaabala-**hum** l-qaat'id-u  
met.3SM-them the-leader-NOM  
'The leader met them.'
- (30) ḍahaba Ahmad-u ?ilai-**ha**  
went.3SM Ahmad-NOM to-it  
'Ahmad went to it.'
- (31) qara?a Ahmad-u kitaab-a-**hu**  
read.3SM Ahmad-NOM book-ACC-his  
'Ahmad read his book.'

This suggests that resumptive and non-resumptive pros are the same element, a phonologically empty pronoun, which is [SLASH {}].

This is essentially a version of an argument developed by McCloskey (2002). He observes (p.192) that RPs universally look just like ordinary pronouns. As Asudeh (2004) points out, this casts doubt on any analysis which treats RPs as special pronouns distinct in some way from ordinary pronouns, and McCloskey (2006) argues that 'there can be no syntactic feature which distinguishes RPs from 'ordinary' pronouns'. We are concerned here with phonologically empty pronouns, but we can say that they look alike because they have the same distribution.

Following much work in HPSG we will assume that the type *synsem* has three subtypes as follows:<sup>4</sup>

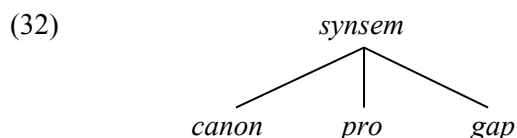

We assume that pros have the following feature makeup:

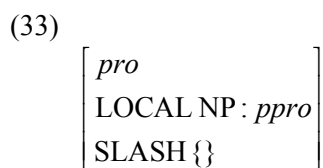

We propose that the distinguishing property of resumptive pros is that they are coindexed with a local feature structure in SLASH. If we assume a head-

---

<sup>4</sup> It may be that *pro* and *gap* should be treated as two subtypes of a *noncanon(ical)* type.

driven approach to SLASH, we can propose that a resumptive *pro* is a pro argument which is coindexed with NP[CASE *nom*] in the SLASH value of a word. In other words, we can propose structures of the following form:<sup>5</sup>

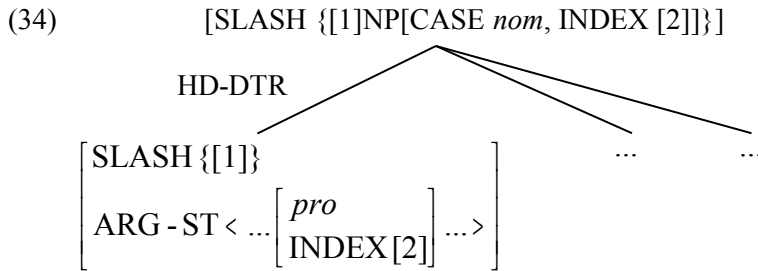

The fact that the *pro* is coindexed with the SLASH value means that it has the same number and gender. Crucially, however, it doesn't require it to have the same case. Hence, the fact that examples like (1b) and (3b) have *pro* in a genitive position is not a problem, and nor is the fact that an example like (5b) has a *pro* in an accusative position.

Within this approach, (1b), with a resumptive *pro* in prepositional object position, will have the following structure:

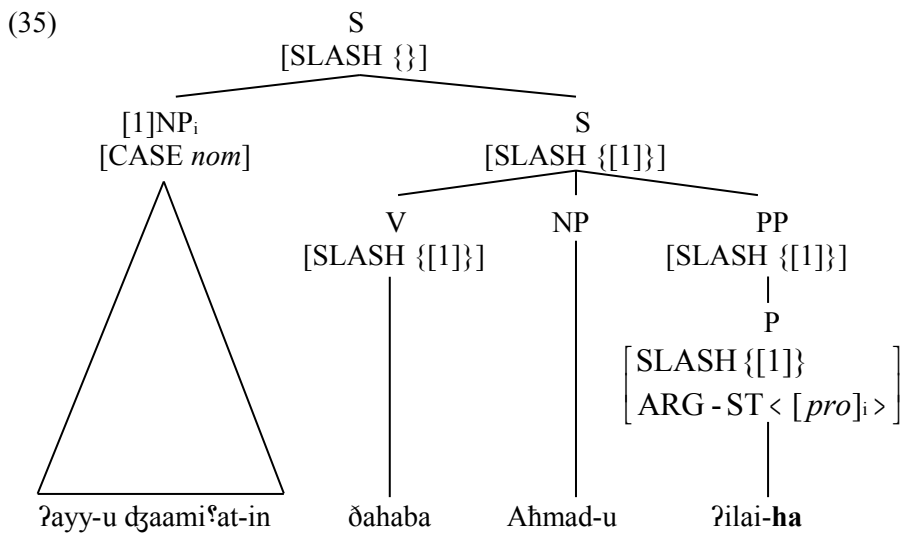

<sup>5</sup> This is essentially the approach that Borsley (2010, 2013) takes to resumptive pronouns in Welsh.

For (5b), with a resumptive *pro* in object position, we will have the structure in (36).

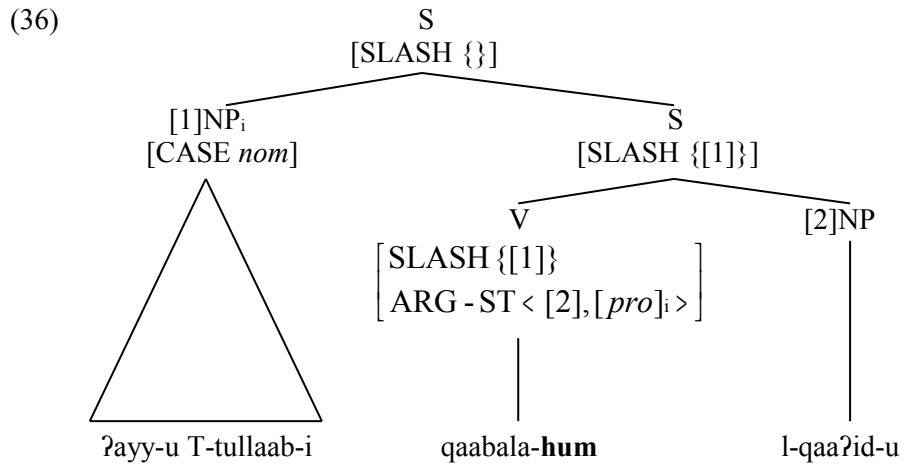

Finally, for (10), with a resumptive *pro* in subject position, we will have (37).

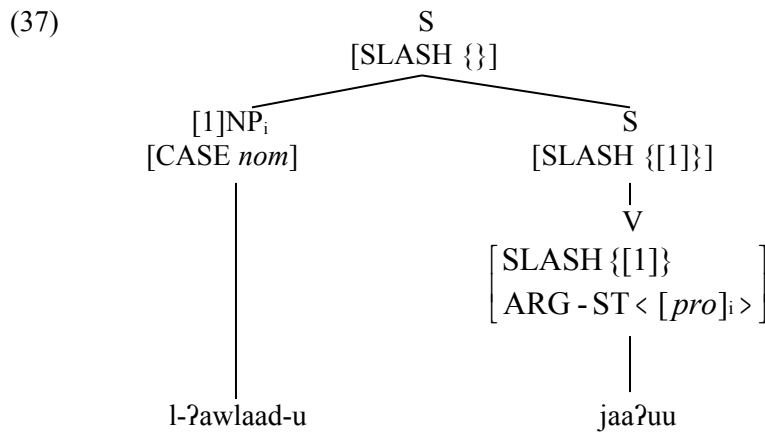

Each of these involves a structure of the form in (34).

What sort of constraints does this approach require? Standard accounts of unbounded dependencies assume that SLASH is subject to the SLASH Amalgamation Principle in (38).

$$(38) \textit{ word} \Rightarrow / \left[ \begin{array}{l} SLASH \{[1] \cup \dots \cup [n]\} \\ ARG-ST \langle [SLASH \{[1]\}], \dots, [SLASH \{[n]\}] \rangle \end{array} \right]$$

This entails that a slashed word must have a slashed argument. This



requirement is met where a head has an argument which is a gap, giving structures of the following form:

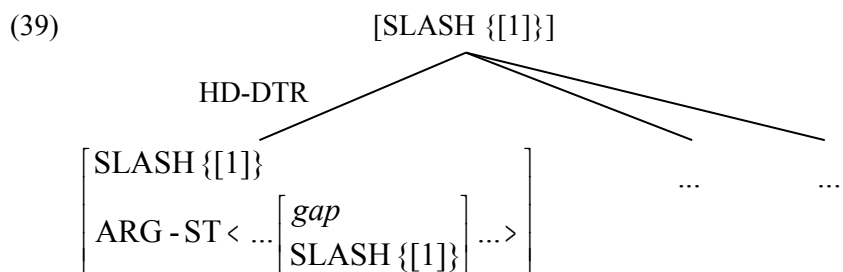

It is also met where a head has an argument which contains a gap or a resumptive, giving structures of the form in (40):

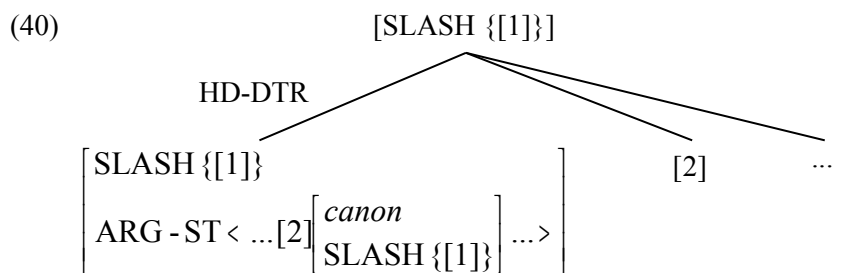

However, the requirement is violated by structures of the form in (34). Hence, it is violated by (35)–(37). The SLASH Amalgamation Principle may be appropriate for languages which just have gaps, but it seems that something more complex is required here.

Firstly, we need a constraint to ensure that a word with a non-empty SLASH value has an argument which is either (a) a gap or a constituent containing a gap or pro or (b) a coindexed pro. The following constraint does this:

$$(41) \left[ \begin{array}{l} \text{word} \\ \text{SLASH \{[1][INDEX [2]]\}} \end{array} \right] \Rightarrow [\text{ARG-ST} < \dots [\text{SLASH \{[1]\}}] \\
 \vee [\text{pro}[\text{INDEX [2]]}]\dots >]$$

We also need a constraint to ensure that a word with a slashed argument is itself slashed in normal circumstances.

$$(42) [\text{ARG-ST} < \dots [\text{SLASH ([1])}] \dots >] \Rightarrow / [\text{SLASH \{[1]\}}]$$

We do not need a parallel constraint requiring a pro argument to be coindexed with a SLASH value because pros need not be resumptive and hence need not be coindexed with a SLASH value. We do, however, need a constraint to ensure that the SLASH value with which a resumptive pro is coindexed is nominative. The following constraint does this:

$$(43) \left[ \begin{array}{l} \textit{word} \\ \text{SLASH } \{[1][\text{INDEX}[2]]\} \\ \text{ARG - ST} < \dots[\textit{pro} [\text{INDEX}[2]]]\dots > \end{array} \right] \Rightarrow [1] = [\text{CASE } \textit{nom}]$$

We turn now to the distribution of gaps. One might suggest that nominal gaps must be accusative. This would exclude gaps from prepositional object, possessor and subject positions. However, we do find nominative gaps in examples like the following:

- (44)  $\text{?ayy-u}$        $\text{rajul-in}$        $\text{Ali-un}$  \_\_\_\_?  
 which-NOM    man-GEN    Ali-NOM  
 ‘Which man is Ali?’

A past tense counterpart has an overt copula, as (45) illustrates.

- (45)  $\text{?ayy-a}$        $\text{rajul-in}$        $\text{kaana}$      $\text{Ali-un}$  \_\_\_\_?  
 which-ACC    man-GEN    was      Ali-NOM  
 ‘Which man was Ali?’

Here an overt form of the copula has a gap as its complement. We assume then that examples like (44) involve a phonologically empty form of the copula with a gap as its complement. On this view, such examples have a complement gap which is nominative. Hence, nominative gaps are acceptable if they are complement gaps. There is also one accusative position in which a gap is not possible. This is the position following complementizer *?anna*, normally occupied by a subject, which is illustrated in (46).

- (46)  $\text{hasiba}$        $\text{Ahmad-u}$       [ $\text{?anna}$      $\text{l-?awlaad-a}$      $\text{ðahabuu}$ ].  
 thought.3SM    Ahmad-NOM    that      the-boys-ACC    left.3PM  
 ‘Ahmad thought the boys had left’

Only a resumptive and not a gap is possible in this position, as the following show:

- (47) a.  $\text{?ayy-u}$        $\text{l-?awlaad-i}$      $\text{hasiba}$        $\text{Ahmad-u}$   
 which-NOM    the-boys-GEN    thought.3SM    Ahmad-NOM

- [ʔanna-**hum**    ḏahabuu]  
 that-they      left.3<sub>PM</sub>  
 ‘Which boys did Ahmad think had left?’
- b. \*ʔayy-a      l-ʔawlaad-i    ḥasiba      Aḥmad-u  
 which-ACC    the-boys-GEN    thought.3<sub>SM</sub>    Ahmad-NOM  
 [ʔanna \_\_\_\_ ḏahabuu]  
 that            left.3<sub>PM</sub>

Instead of using case to restrict gaps, we propose to restrict them to being complements of a verb or adjective with the following constraint:

(48)

$$[1][gap] \Rightarrow \left[ \begin{array}{l} \text{HEAD } verb \vee adj \\ \text{ARG - ST } \langle [] \rangle \oplus \langle \dots [1] \dots \rangle \end{array} \right]$$

This will include adverbial gaps if we assume that adverbials are extra members of ARG-ST lists (Ginzburg and Sag 2000: 168, fn.2). It is essentially a restricted version of the Trace Principle of Pollard and Sag (1994, section 4.4).

There is a further restriction on gaps that we need to consider. We noted earlier that while definite relatives allow both a gap and a resumptive clitic in object position, indefinite relatives only allow the latter in this position. To account for this contrast we need to ensure that the former are [SLASH {NP}] with no case restriction while the latter are [SLASH {NP[CASE *nom*}]]. If we assume with Alqurashi and Borsley (2012) that definite relatives are headed by the complementizer *llaḏi* while indefinite relatives are headed by a phonologically empty complementizer, we can propose that the former has the description in (49) while the latter has that in (50).

(49)

$$\left[ \begin{array}{l} \text{HEAD} \left[ \begin{array}{l} c \\ \text{MOD NP[DEF +, INDEX [1]]} \end{array} \right] \\ \text{COMPS} \langle \text{S[SLASH \{NP[INDEX [1]]\}] \rangle} \end{array} \right]$$

(50)

$$\left[ \begin{array}{l} \text{HEAD} \left[ \begin{array}{l} c \\ \text{MOD NP[DEF -, INDEX [1]]} \end{array} \right] \\ \text{COMPS} \langle \text{S[SLASH \{NP[CASE } *nom*, \text{INDEX [1]]\}] \rangle} \end{array} \right]$$

This will ensure that indefinite relatives can only have a resumptive clitic and not a gap in object position.

#### 4. More on coordination

An important issue arises with examples like (24), which have a gap in one conjunct and a resumptive *pro* in the other. On the face of it, such examples will have [SLASH {NP[CASE *acc*]}] in the first conjunct because the gap is accusative and [SLASH {NP[CASE *nom*]}] in the second conjunct because of the resumptive *pro*. This looks like a problem. However, following Levine, Hukari and Calcagno (2000), we can assume a type *nom&acc*, which is a subtype of both *nom* and *acc* and propose that *man* and the associated SLASH value are [CASE *nom&acc*]. This satisfies both the accusative requirement stemming from the gap and the nominative requirement stemming from the resumptive *pro* and constraint in (40).<sup>6</sup>

It seems, then, that examples like (24) are no problem. Clearly, however, we should ask about similar examples where the *wh*-phrase is unambiguously accusative or nominative. Consider, then, the following:

- (51) ?ayy-a            Tullaab-in    [qaabalta    \_\_\_ wa    tahaddaθa  
       which-ACC    students-GEN    met.2SM            and    talked.2SM  
       ?ilai-**hum**]?  
       to-them  
       ‘Which students have you met and talked to?’
- (52) ??ayy-u            Tullaab-in    [qaabalta    \_\_\_ wa    tahaddaθa  
       which-NOM    students-GEN    met.2SM            and    talked.2SM  
       ?ilai-**hum**]?  
       to-them  
       ‘Which students have you met and talked to?’

Speakers generally find examples like (51) with an accusative *wh*-phrase acceptable. They find examples like (52) with a nominative *wh*-phrase less acceptable, but they do not generally reject them. This is quite challenging. On the face of it, the coordinate structure in (51) has the structure in (53), while that in (52) has the structure in (54).

---

<sup>6</sup> *Man* can also occupy a genitive position, as (i) shows:

- (i) [<sub>NP</sub> kitaab-a    man] gara?a    \_\_\_    Ahmad-u?  
       book-ACC    whoread.3SM            Ahmad-NOM  
       ‘Whose book has Ahmad read?’

This suggests that *man* should in fact be [CASE *nom&acc&gen*], where *nom&acc&gen* is a subtype of *nom* and *acc* and *gen*.

- (53) [SLASH {NP[CASE *acc*]}]  
 [SLASH {NP[CASE *acc*]}] [SLASH {NP[CASE *nom*]}]
- (54) [SLASH {NP[CASE *nom*]}]  
 [SLASH {NP[CASE *acc*]}] [SLASH {NP[CASE *nom*]}]

Given the standard assumption that conjuncts have the same value for SLASH, these should be ill-formed. It looks as if it may be necessary to weaken this assumption. However, there may be an alternative explanation for speakers' judgements.

An important fact about MSA is that it is not anyone's native language. Rather it is the product of formal education. The native language of all users of MSA is one of the dialects of Arabic. These do not have morphological case. Hence with dialectal counterparts of (51) and (52) there is no issue about case and their acceptability is unproblematic. It may be, then, that speakers judging examples like (51) and (52) are influenced by their dialectal counterparts.

This may explain why speakers find examples like (51) and (52) acceptable but what about the fact that (52) is less acceptable than (51)? It may be that this is a reflection of the fact that (51) without the second conjunct is the grammatical sentence in (55), while (52) without the second conjunct is the ungrammatical sentence in (56).

- (55) ?*ayy-a*      *Tullaab-in*      *qaabalta* \_\_\_?  
 which-ACC    students-GEN    met.2SM  
 'Which students have you met?'
- (56) \*?*ayy-u*      *Tullaab-in*      *qaabalta* \_\_\_?  
 which-NOM    students-GEN    met.2SM

(56) is ungrammatical because the filler has a different case from the gap. It seems likely that speakers' judgements on examples like (51) and (52) are influenced by (55) and (56).

### 5. ?*anna*-clauses

There is another construction that is unproblematic for the approach developed above. This is a type of subordinate clause introduced by ?*anna*, which we assume is a complementizer. Here is a typical example:

- (57)  $\zeta$ alimtu [ʔanna l-ʔawlaad-a qaabaluu Aliy-an]  
 knew.1SM that the-boys-ACC met.3PM Ali-ACC  
 ‘I knew that the boys have met Ali’

Here, *ʔanna* is followed by an accusative NP, which is interpreted as the subject of the following verb. One might suppose that *ʔanna*-clauses are rather like English *for-to* clauses. However, the accusative NP is not always interpreted as the subject. In the following it is interpreted an object.

- (58)  $\zeta$ alimtu [ʔanna l-qiSat-a garaʔa-**ha** Ahmad-u]  
 knew.1SM that the-story-ACC read.3SM-it Ahmad-NOM  
 ‘I knew that (as for) the story, Ahmad read it.’

Notice that there is a clitic in this example. A similar example with a gap is ungrammatical:

- (59) \* $\zeta$ alimtu [ʔanna l-qiSat-a garaʔa Ahmad-u \_\_\_\_]  
 knew.1SM that the-story-ACC read.3SM-it Ahmad-NOM  
 ‘I knew that (as for) the story, Ahmad read it.’

We also have examples where the accusative NP is associated with a clitic attached to a preposition or a noun:

- (60)  $\zeta$ alimtu [ʔanna l-baiit-a kaan fii-**hi** rajul-un]  
 knew.1SM that the-house-ACC was in-it man-NOM  
 ‘I knew that there was a man in the house.’
- (61)  $\zeta$ alimtu [ʔanna l-baiit-a kasara Ahmad-u  
 knew.1SM that the-house-ACC broke.3SM Ahmad-NOM  
 baaba-**hu**]  
 door-ACC-it  
 ‘I knew that Ahmad broke the house door’

It seems that what we have in an *ʔanna*-clause is an accusative NP followed by a clause which is rather like an indefinite relative. As with an indefinite relative we can account for its properties by assuming that it is [SLASH {NP[CASE *nom*]}]. This will be realized as a *pro* in subject position ((57)) or in a position associated with a clitic ((58), (59), (61)). The NP in the value of SLASH must be coindexed with the accusative NP. Thus, we can propose the following category for *ʔanna*:

(62)

$$\left[ \begin{array}{l} \text{HEAD } c \\ \text{SUBJ } \langle \rangle \\ \text{COMPS } \langle \text{NP}[\text{CASE } acc, \text{INDEX}[1]], \\ \text{S}[\text{SLASH } \{\text{NP}[\text{CASE } nom, \text{INDEX}[1]]\}] \rangle \end{array} \right]$$

As one might expect, it is possible to have a gap in object position as long as it is not associated with the accusative NP following *?anna*. Consider the following:

(63) man ta<sup>ʕ</sup>taqidu [?anna l-?awlaad-a qaabaluu \_\_\_]?  
who think.2SM that the-boys-ACC met.3PM  
‘Who do you think that the boys have met?’

This is *wh*-question and the gap in object position is associated with the *wh*-word *man*. As in (57), the accusative NP is associated with a *pro* in subject position.

## 6. Conclusions

In this paper we have investigated the behaviour of gaps and null resumptive pronouns in MSA. They differ in their distribution, but we have argued on the basis of coordination that both are realizations of the SLASH. We have argued that null resumptive pronouns are just ordinary null pronouns coindexed with the SLASH value of some head. Within this approach the fact that null resumptive pronouns generally have a different case from an associated filler is unproblematic. We have shown that the facts can be accounted for by a small number of constraints. We have also shown that there is no difficulty in accounting for the contrast between *wh*-questions and relative clauses with a definite antecedent, which allow a gap in object position, and relative clauses with an indefinite antecedent and *?anna*-clauses, which do not. The SLASH value of the former can have any value for CASE, whereas the SLASH value of the latter is NP[CASE *nom*]. It seems, then, that it is not too difficult to accommodate the facts within HPSG.

## REFERENCES

Alqurashi, A. and R. D. Borsley (2012), Arabic Relative Clauses in HPSG, in S. Müller (ed.), *Proceedings of the HPSG12 Conference*, Stanford: CSLI Publications, 26–44.

- Aoun, E. J., E. Benmamoun, and L. Choueiri (2010), *The Syntax of Arabic*, Cambridge: Cambridge University Press.
- Asudeh, A. (2004), *Resumption as Resource Management*, Ph.D. dissertation, Stanford University.
- Borsley, R. D. (2010), An HPSG approach to Welsh unbounded dependencies, in S. Müller (ed.), *Proceedings of the HPSG10 Conference*, Stanford: CSLI Publications, 47–67.
- Borsley, R. D. (2013), On the nature of Welsh unbounded dependencies, *Lingua* 133, 1–29.
- Crysmann, B. (2012), Resumption and islandhood in Hausa, in P. de Groote and M.-J. Nederhof (eds.), *Formal Grammar. 15th and 16th International Conference on Formal Grammar*, Springer, Heidelberg, pp. 50–65.
- Fassi Fehri, A. (1993), *Issues in the Structure of Arabic Clauses and Words*, Dordrecht, Holland: Kluwer Academic Publishers.
- Ginzburg, J. and I. A. Sag (2000), *Interrogative Investigations: The Form, Meaning and Use of English Interrogatives*, Stanford: CSLI Publications.
- Goldsmith, J. (1985), A principled exception to the coordinate structure constraint. *CLS* 21, 133–143.
- Hofmeister, P. and I. A. Sag (2010), Cognitive constraints and island effects. *Language* 86, 366–415.
- Hofmeister, P., L. Staum Casasanto, and I. A. Sag (in press), Islands in the grammar? Standards of evidence, in J. Sprouse, and N. Hornstein (eds.), *Experimental Syntax and Island Effects*.
- Keenan, E. L. and B. Comrie (1977), Noun phrase accessibility and universal grammar, *Linguistic Inquiry* 8, 63–99.
- Kehler, A. (2002), *Coherence, Reference and the Theory of Grammar*. CSLI Publications, Stanford.
- Kluender, R., (1998), On the distinction between strong and weak islands: A processing perspective, in P. W. Culicover and L. McNally (eds.), *Syntax and Semantics 29*. Academic Press, New York, pp. 241–279.
- Koopman, H (1983), ECP effects in main clauses, *Linguistic Inquiry* 15, 211–258.
- Lakoff, G. (1986), Frame semantic control of the coordinate structure constraint, *CLS 22, Part 2: Papers from the Parasession on Pragmatics and Grammatical Theory*, 152–167.
- Levine, R. D. and T. E. Hukari (2006), *The Unity of Unbounded Dependency Constructions* Stanford, CA: Center for the Study of Language and Information.
- Levine, R. D., T. E. Hukari and M. Calcagno (2000), Some overlooked parasitic gap constructions in English and their theoretical implications, in P. Culicover and P. M. Postal (eds.), *Parasitic Gaps*. Cambridge, Mass: MIT Press, pp.181–222.
- McCloskey, J. (2002), Resumption, successive cyclicity and the locality of



- operations, in. S. D. Epstein and T. D. Seeley (eds.), *Derivation and Explanation in the Minimalist Program*, Oxford: Blackwell, pp. 184–226.
- McCloskey, J. (2006), Resumption, in M. Everaert and H. van Riemsdijk (eds.), *The Blackwell Companion to Syntax*, Oxford: Blackwell, pp. 94–117.
- Miller, P. and I. A. Sag (1997), French clitic movement without clitics or movement. *Natural Language and Linguistic Theory* 15, 573–639
- Mohammad M. (2000), *Word Order, Agreement and Pronominalization in Standard and Palestinian Arabic*, John Benjamins Publishing Company. Amsterdam/ Philadelphia.
- Pollard, C. and I. A. Sag (1994), *Head-driven Phrase Structure Grammar*, Chicago: University of Chicago Press.
- Ross, J. R. (1967), *Constraints on Variables in Syntax*. PhD dissertation, MIT.
- Vaillette, N. (2000), Hebrew relative clauses in HPSG, *Proceedings of the 7th International Conference on Head-Driven Phrase Structure Grammar*, CSLI Publications. 305–324.
- Vaillette, N., (2002), Irish gaps and resumptive pronouns in HPSG, *Proceedings of the 8th International Conference on Head-Driven Phrase Structure Grammar*, CSLI Publications. 284–299.

# Morphotactics in an information-based model of realisational morphology

Olivier Bonami 

Université Paris-Sorbonne  
Institut universitaire de France  
LLF (UMR 7110)

Berthold Crysmann 

CNRS  
LLF (UMR 7110)

Proceedings of the 20th International Conference on  
Head-Driven Phrase Structure Grammar

Freie Universität Berlin

Stefan Müller (Editor)

2013

Stanford, CA: CSLI Publications

pages 27–47

Bonami, Olivier & Berthold Crysmann. 2013. Morphotactics in an information-based model of realisational morphology. In Stefan Müller (ed.), *Proceedings of the 20th International Conference on Head-Driven Phrase Structure Grammar, Freie Universität Berlin*, 27–47. Stanford, CA: CSLI Publications. DOI: 10.21248/hpsg.2013.2. 

## Abstract

In most recent work, Crysmann and Bonami (2012) suggest to reconcile the insights of inferential-realisation morphology (Anderson, 1992; Stump, 2001; Brown and Hippisley, 2012) with the full typology of variable morphotactics: situations where the expression of analogous feature sets can appear in various positions in the string. The authors proposed to account for these facts by importing, into HPSG, a variant of Paradigm Function Morphology (Stump, 2001) where realisation rules are doubly indexed for linear position and paradigmatic opposition. In this paper we first introduce more empirical challenges for theories of morphotactics that neither PFM nor the reformist approach of Crysmann and Bonami (2012) can accommodate. We then argue for a reappraisal of methods for morph introduction, and propose a new approach that replaces stipulation of classes of paradigmatic opposition with a general distinction between expression and conditioning (Carstairs, 1987; Noyer, 1992) which greatly expands the scope of Pāṇini’s Principle.

# 1 Variable morph ordering

## 1.1 Types of non-canonical morphotactics

In the inflection of a particular lexical category in a given language, morphs are most canonically organised in a sequence of POSITION CLASSES: morphs expressing different values for the same feature cluster in a single linear position, strictly ordered with respect to positions serving for the realisation of other features.<sup>1</sup> Of course, deviations from this canonical ideal are very common, and come in many varieties; most well-known are FUSED EXPONENCE (a single position realises more than one feature), EXTENDED EXPONENCE (the same feature is realised simultaneously in multiple positions), and ZERO EXPONENCE (some feature is not expressed at all); these famously motivate the Word and Paradigm family of approaches to inflection (Matthews, 1972).

A family of deviations of particular interest is that of VARIABLE MORPH ORDERING. This again comes in multiple varieties. In POSITIONAL DISAMBIGUATION, the same morph expresses related but distinct morphosyntactic property sets in different positions. A nice example is that of subject and object markers in Swahili (Stump, 1993),

---

<sup>†</sup>We would like to thank the audience of HPSG 2013, in particular Doug Arnold, Rob Malouf, Jesse Tseng, and Frank van Eynde. We are also greatly indebted to Greg Stump for his highly stimulating reactions, suggestions and constructive criticism he shared with us on various occasions. Previous versions of the present paper have also been presented at the First American International Morphology Meeting 2012 at Amherst and at a seminar at the University of Essex. We therefore would like to extend our thanks to the respective audiences of these two venues, in particular to Farrell Ackerman, Mark Aronoff, Louisa Sadler, and Andrew Spencer. Of course, the usual disclaimers apply. This work is related to work package *Morph1* of Labex EFL (funded by the ANR/CGI). Participation at HPSG 2013 was supported by the project TranSem, funded by the CNRS programme PEPS HuMaIn.

Authors’ names are listed in alphabetical order, sorted by last name for a change.

<sup>1</sup>Whether the relative order of these positions should be assumed to be canonically correlated with the identity of the features (Bybee, 1985; Rice, 2000; Aronoff and Xu, 2010) is debatable. However we assume without discussion, with e.g. Stump (1993, 2001); Nordlinger (2010) that the relative order is often arbitrary, and we focus on the treatment of the arbitrary cases.

as illustrated in Table 1: these markers are homophonous for most nominal classes, but do not appear in the same position within the verb.

PER	GEN	SUBJECT		OBJECT	
		SG	PL	SG	PL
1		ni	tu	ni	tu
2		u	m	ku	wa
3	M/WA	a	wa	m	wa
	M/MI	u	i	u	i
	KI/VI	ki	vi	ki	vi
	JI/MA	li	ya	li	ya
	N/N	i	zi	i	zi
	U	u	—	u	—
	U/N	u	zi	u	zi
	KU	ku	—	ku	—

Table 1: Subject and object prefixes in Swahili

In MISALIGNED EXPONENCE, morphs that are in paradigmatic opposition appear in different linear positions. The Laz subject markers in Table 2 exemplify (Lacroix, 2009): with intransitive verbs, subject agreement is marked suffixally by default, prefixally in the first person, and both prefixally and suffixally in the 1PL.

LAL ‘bark’		
	SG	PL
1	b-lalum	b-lalum-t
2	lalum	lalum-t
3	lalum-s	lalum-an

Table 2: Subject marking on simple intransitive verbs in Laz

In CONDITIONED REORDERING, one and the same morph expressing the same property set appears in different linear positions depending on some (phonological, morphosyntactic, or semantic) condition.<sup>2</sup> Mari nominal declension offers a relevant example (Luutonen, 1997), as shown in Table 3: in the accusative, the possessor marker precedes the case marker, while in the lative, it is the other way round. In FREE REORDERING, the expression of some combination of morphosyntactic properties relies on two morphs whose relative order is not constrained by the grammar. This is also found in Mari declension, in the dative.

From a theoretical point of view, the Mari data are highly informative, since they actually provide the missing typological link between free ordering, as observed for Chintang (Bickel et al., 2007) and conditioned reordering, as manifest in Laz or Fula (Stump, 1993): systems that feature essentially free permutation, but are constrained for some cells, lend themselves quite naturally to an analysis in frameworks that build

<sup>2</sup>Reversible and ambifixal position classes (Stump, 1993) are two subcases of conditioned reordering.

	NOPOSS	1 PL.POSS	
		POSS < CASE	CASE < POSS
NOM	пöрт	пöрт-на	
ACC	пöрт-ым	пöрт-на-м	*
DAT	пöрт-лан	пöрт-на-лан	пöрт-лан-на
LAT	пöрт-еш	*	пöрт-еш-на

Table 3: Partial paradigm of Mari possessed nouns (Riese et al., 2010)

on the accumulation of partial descriptions.

## 1.2 Approaches to variable morphotactics

Within the Word and Paradigm tradition, the most prevalent view of morphotactics rests on three crucial assumptions (Anderson, 1992; Stump, 2001): (i) morphological composition is stem-centric: it starts from the lexeme’s basic stem which it modifies incrementally by sequential application of morpholexical rules; (ii) morpholexical rules operate on morphologically unstructured (‘a-morphous’) phonological representations; (iii) morpholexical rules are organised into blocks of mutual exclusivity.

This set of assumptions gives rise to a view of morphotactics where exponents in paradigmatic opposition are expected to linearise in onion-like fashion, as outlined in Fig. 1. Deviations from this expectation have been recognised early on, and dealt with using different analytic devices over the years: metarules (Stump, 1993), rules of referral (Stump, 2001), or conditional operators of composition and linearisation (Stump, 2012a,b). Still, all these proposals share the view that the kind of morphotactic structure illustrated by Fig. 1 is the least marked.

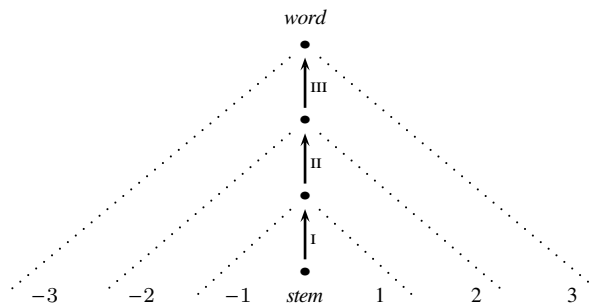

Figure 1: The interaction of rule blocks and morphotactics

Crysmann and Bonami (2012) challenge this assumption, and argue that the types of variable morphotactics found in the languages of the world do not warrant taking any type of variable morphotactics as less marked: what is less marked is to not have any variation in order, but there is no preference for variations that occur in onion-like fashion around the stem. Crucial to their argumentation is the pattern commonly

found with Romance pronominal affixes, here illustrated with Italian (Monachesi, 1999), where sequences of affixes occur in the same order on either side of the stem (see also Luís and Spencer, 2005).

- |     |    |                                |    |                              |
|-----|----|--------------------------------|----|------------------------------|
| (1) | a. | me-lo-dai                      | b. | dá-me-lo!                    |
|     |    | DAT.1SG-ACC.3SG.M-give.PRS.2SG |    | give.IMP.2SG-DAT.1SG-ACC.3SG |
|     |    | ‘You give it to me.’           |    | ‘Give it to me!’             |

Crysmann and Bonami (2012) propose a reformist modification of standard assumptions amounting to dropping (1) above: instead of licensing inflected words starting from the stem, they start from the left edge of the word and delay the introduction of the stem. Morpholexical rules carry an explicit position class index, and order variability is dealt with by underspecification of position class. Crucially, this analytic setup enables Crysmann and Bonami to deal with a wider typology of variable morphotactics while keeping two central analytic assumptions: the a-morphous hypothesis and the organisation of rules into blocks.

## 2 New challenges

### 2.1 Rule blocks and position classes

While Crysmann and Bonami (2012) arguably provides for a more refined theory of variable morphotactics than its predecessors, the proposed formal analysis is a hybrid, which ends up having unsatisfactory design properties. Particularly inelegant is the double indexing of morpholexical rules for rule blocks (encoding paradigmatic opposition) and position class (encoding syntagmatic order). While some indexing scheme for positions is indisputably necessary, the necessity of block indices is far less clear in a system where these indices are dissociated from linear order.

When stripped of their function of deriving linear order, what rule blocks appear to do is just ascertain morphological wellformedness: in inferential-realisational models of morphology and constraint-based grammar alike, a bare stem, being underspecified, may denote any cell of the paradigm, the only problem being that such a stem more often than not fails to constitute a legitimate morphologically well-formed word. Thus, one of the two remaining functions of rule blocks is to ensure that any inflectional feature that has some expression must be expressed and that cases of zero exponence are limited to the cells in the paradigm for which the system provides no exponent. The other remaining function for rule blocks is to limit the scope of Pāṇinian competition, in order to permit instances of extended exponence, i.e., multiple expression of same or overlapping morphosyntactic properties (see section 3.2). But if rule blocks are divorced from the expression of constraints on order, one ends up with a completely unconstrained way of exempting morphs from Pāṇinian competition, severely undermining the status of Pāṇinian competition as an organisational principle of morphological systems.

Another problematic issue with Crysmann and Bonami (2012) — actually a defect inherited from the PFM model — concerns their treatment of the identity func-

tion default (*ifd*), i.e., the morpholexical rule to account for zero exponence: ideally, there should only be one such default realisation rule that captures every morphosyntactic property that does not have an independent overt realisation. However, owing to the logic of rule blocks, Crysmann and Bonami (2012) need to postulate not only multiple instances of the same default rule, but also need to ensure that such an instance exists for every rule block.

More generally, within the context of information-based syntax and semantics, the idea of stipulating a system of ordered or unordered rule blocks merely for the purposes of ensuring morphological wellformedness should come as a bit of an embarrassment, even more so, if wellformedness can be simply captured by a straightforward principle: every property that can be expressed, needs to be expressed. In this paper, we shall develop a model of realisational morphology within HPSG that replaces stipulated static blocks of paradigmatic opposition with a general principle that manages the expression of morphosyntactic resources. We will show that this approach is not only preferable on a conceptual level, but also supported by an increase in analytical elegance and empirical coverage.

## 2.2 Challenging a-morphousness

Wackernagel affixes are affixes that are constrained to be the second realised morph in the word (Nevis and Joseph, 1992). A clear example is provided by Sorani Kurdish (Samvelian, 2007) and illustrated in Table 4. In past transitive verbs, if the verb is VP initial, the set of markers realising subject agreement are realised immediately after the first other morph, irrespective of whether that morph is the basic stem, a negative prefix, or an aspectual prefix.<sup>3</sup>

1	2	3	4	
		nard= <b>jân</b>	im	‘they sent me’
na= <b>jân</b>		nard	im	‘they did not send me’
	da= <b>jân</b>	nard	im	‘they were sending me’
na= <b>jân</b>	da	nard	im	‘they were not sending me’

Table 4: Sorani Kurdish past person markers

Wackernagel affixes pose a serious challenge to the a-morphousness assumption. In order to know where to linearise the affix, one needs to keep track of the position of the first overtly realised morph in the word. Both in conventional stem-centric approaches and in Crysmann and Bonami (2012)’s left-to-right approach, this information is inaccessible: the morpholexical rule introducing **jân** can only access phonological properties of its input, not morphological properties; thus irrespective of the order in which rules apply, there is no way of checking what the morphological structure of

<sup>3</sup>See section 4 for a more detailed description.

the sequence on the right of the affix is.<sup>4</sup> Stump (2012b) circumvents this problem by redefining realisation rules so that they construct two phonological strings in parallel: in addition to the full phonological representation, realisation rules recursively define the *pivot*, the substring of the whole phonology at whose edge Wackernagel affixes are to be realised. We would argue that this amounts to abandoning the spirit, if not the letter, of the amorphous hypothesis: using morphologically segmented phonological strings or recording separately the location of morph boundaries are just two equivalent ways of remembering where those boundaries are. In the remainder of this paper we suggest a more direct approach to this phenomenology.

### 3 Analysis

#### 3.1 Information-based realisational morphology

Inferential-realisation models of morphology typically draw a distinction between morpholexical rules (or realisation rules), which provide recipes for the introduction of exponents, and a system of paradigm functions that concert the way in which these recipes are applied to yield a well-formed word. In a-morphous approaches, such as Anderson (1992); Stump (2001); Crysmann and Bonami (2012), morpholexical rules are formulated as (potentially recursive) unary rules. Paradigm functions then guarantee that exactly the right number of rules are invoked, in the right order. Choice between competing rules is currently understood as being governed by Pāṇinian competition. This division of labour between morpholexical rules and paradigm function has proven quite successful, since it permits reuse of resources, as needed, e.g., for the treatment of positional disambiguation (cf. table 1; Stump, 1993; Crysmann and Bonami, 2012).

While keeping this general division, we shall revise the formal nature of morpholexical rules: instead of rule cascades successively transforming a basic stem into a complete word, rules will be considered instead as pairings between morphosyntactic properties and lists of exponents. Building on ideas proposed in Crysmann (2002), we postulate a flat structure of segmentable morphs (not morphemes) which are indexed for position. In essence, we are moving structure away from the derivation history into morphological representations. This move actually provides for a more restrictive model, since it systematically disallows reference to the derivation history.

Morpholexical rules are represented by feature structures organised in a type hierarchy, providing a pairing of a list of MORPHS with the morphosyntactic features they express (M(ORPHOLOGY) U(NDER) D(ISCUSION)). In order to capture allomorphic conditioning, morpholexical rules may impose constraints on morphosyntactic properties they do not strictly realise, e.g. the negative allomorph of the Swahili past marker in

---

<sup>4</sup>This is not literally true of Crysmann and Bonami (2012)'s approach, because of a technical defect in the formulation of realisation rules: the authors code recursion of realisation rules by the HPSG-standard use of a DTR feature. Thus in fact the whole derivation history is accessible to later rule application. This is clearly a poor design choice that does not correspond to the intended a-morphous interpretation of rules.



(2). The morphs thus introduced consist of a phonological description (PH) together with a position class index (PC). The formal encoding of position class indices is discussed in the appendix.

$$(2) \left[ \begin{array}{l} \text{MUD} \quad \boxed{1} \{past\} \\ \text{MORSYN} \quad \boxed{1} \cup \{neg, \dots\} \\ \text{MORPHS} \quad \left\langle \begin{array}{l} \text{PH} \quad \langle ku \rangle \\ \text{PC} \quad 3 \end{array} \right\rangle \end{array} \right]$$

Since morpholexical rules “know” what features they express (MUD), we can define morphological completeness and coherence in terms of resource consumption: as stated in (3), the morphosyntactic features expressed by morphological rules must match up to produce the morphosyntactic property set of the word. As for exponence, we compute the MORPHS list of a word by shuffling all the morphs contributed by the morpholexical rules in the order of their position class indices.<sup>5</sup>

$$(3) \quad word \rightarrow \left[ \begin{array}{l} \text{MORPHS} \quad \boxed{e_1} \circ \dots \circ \boxed{e_n} \\ \text{MORSYN} \quad \boxed{0} (\boxed{m_1} \uplus \dots \uplus \boxed{m_n}) \\ \text{RULES} \quad \left\langle \begin{array}{l} \text{MORPHS} \quad \boxed{e_1} \\ \text{MUD} \quad \boxed{m_1} \\ \text{MORSYN} \quad \boxed{0} \end{array} \right\rangle, \dots, \left\langle \begin{array}{l} \text{MORPHS} \quad \boxed{e_n} \\ \text{MUD} \quad \boxed{m_n} \\ \text{MORSYN} \quad \boxed{0} \end{array} \right\rangle \end{array} \right]$$

Compared to Crysmann and Bonami (2012), position class information is considered a property of the morphs here, rather than a property of rules. Note further that there are no rule block indices (or POI), ensuring morphological completeness and coherence entirely in terms of the principle in (3). As a direct consequence, we extend the scope of Pāṇinian competition to all maximally specific types:

- (4) a. For any leaf type  $t_1[\text{MUD } \mu_1, \text{MORSYN } \sigma]$ ,  $t_2[\text{MUD } \mu_2, \text{MORSYN } \sigma \wedge \tau]$  is a morphological competitor, iff  $\mu_1 \subseteq \mu_2$ .
- b. For any leaf type  $t_1$  with competitor  $t_2$ , expand  $t_1$ 's MORSYN  $\sigma$  with the negation of  $t_2$ 's MORSYN  $\sigma \wedge \tau$ :  $\sigma \wedge \neg(\sigma \wedge \tau) \equiv \sigma \wedge \neg\tau$ .

Essentially, we formulate Pāṇini's Principle solely in terms of the information being expressed: morpholexical rules that express more properties (MUD) compete with those that express less, and those that have more specific conditioning (MORSYN) compete with those that are less strictly conditioned. Our version of Pāṇini's Principle has the further benefit that we only need a single instance of the identity function default (*ifd*), the morpholexical rule that deals with zero exponence:

<sup>5</sup>Morph lists are shuffled rather than simply concatenated because we want to allow a single rule to introduce two (or more) possibly discontinuous morphs simultaneously: in such a situation a separate rule may introduce a morph in an intermediate position. “ $\uplus$ ” denotes disjoint union:  $X \uplus Y = X \cup Y$  if  $X \cap Y = \emptyset$  and is undefined otherwise. Note that although we take RULES to be a list rather than a set, the relative order of elements in RULES currently plays no role in our analyses.

$$(5) \begin{bmatrix} \text{MORPHS} & \langle \rangle \\ \text{MUD} & \boxed{1} \left\{ \left[ \right] \right\} \\ \text{MORSYN} & \boxed{1} \cup \text{set} \end{bmatrix}$$

Since the *ifd* specifies one completely underspecified MUD value, it is in competition with every other morpholexical rule, having its MORSYN value restricted to exactly those morphosyntactic features that do not have any independent expression, which is clearly a desirable result.

In the following two subsections, we show that this approach provides for a more general and less stipulative approach to competition and variable morphotactics.

### 3.2 Swahili negative marking

The first set of data we are going to investigate in detail pertains to Pāṇinian competition between different position classes and the treatment of extended exponence.

In Swahili, sentential negation is regularly marked by means of the prefix *ha* in slot 1 of the verb (cf. (6a)). However, if the verb is inflected for relative agreement, negation is expressed instead by the marker *si* in slot 3. Since *si* in (6b) is the only overt exponent of negative marking, we must conclude that negative relative *si* expresses negation, preempting the use of the regular negative marker *ha* (6c).

- (6) a. **ha-** wa- ta- taka  
 NEG 3PL FUT want  
 ‘they will not want’
- b. watu wa- **si-** o- soma  
 people 3PL NEG.REL REL.PL read  
 ‘people who do not read’
- c. \* watu **ha-** wa- \*(**si-**) o- soma  
 people NEG 3PL NEG.REL REL.PL read

In PFM, where Pāṇini’s principle is limited to individual rule blocks, and rule blocks are tied to linear position, there is no way to capture this directly. Under our purely information-based approach, preemption of *ha* by *si* follows directly given the proper subsumption of MORSYN specifications.

$$(7) \text{ a. } \begin{bmatrix} \text{MUD} & \{neg\} \\ \text{MORSYN} & \text{set} \\ \text{MORPHS} & \left\langle \left[ \begin{array}{l} \text{PH} <ha> \\ \text{PC} 1 \end{array} \right] \right\rangle \end{bmatrix}$$

$$b. \left[ \begin{array}{l} \text{MUD} \quad \left\{ \begin{array}{l} \textit{neg} \end{array} \right\} \\ \text{MORSYN} \quad \left\{ \textit{rel} \right\} \cup \textit{set} \\ \text{MORPHS} \quad \left\langle \left[ \begin{array}{ll} \text{PH} & \langle \textit{si} \rangle \\ \text{PC} & 3 \end{array} \right] \right\rangle \end{array} \right]$$

Similarly, we can also derive competition between regular markers and portman-teaux without any stipulation in terms of rule block indices, contrary to Stump (1993) and Crysmann and Bonami (2012): as witnessed in (8), the 1sg negative portmanteau *si* simultaneously preempts the regular marker of negation *ha* and the regular marker of 1st singular subject agreement *ni*.

- (8) a. (ha-) a- ta- ku- taka  
 NEG 3SG.SUBJ FUT 2SG.OBJ pay  
 ‘He will (not) pay you.’
- b. (\*ha-) ni- ta- ku- taka  
 NEG 1SG.SUBJ FUT 2SG.OBJ pay  
 ‘I will (\*not) pay you.’
- c. si- ta- ku- taka  
 NEG.1SG.SUBJ FUT 2SG.OBJ pay  
 ‘I will not pay you.’

Again, Pāṇini’s principle directly accounts for preemption, based on the subset relation of MUD values. See the appendix on the simultaneous occupancy of two position classes.

$$(9) \quad a. \left[ \begin{array}{l} \text{MUD} \quad \left\{ \left[ \begin{array}{l} \textit{subj} \\ \text{PER} \quad 1 \\ \text{NUM} \quad \textit{sg} \end{array} \right] \right\} \\ \text{MORPHS} \quad \left\langle \left[ \begin{array}{ll} \text{PH} & \langle \textit{ni} \rangle \\ \text{PC} & 2 \end{array} \right] \right\rangle \end{array} \right]$$

$$b. \left[ \begin{array}{l} \text{MUD} \quad \left\{ \begin{array}{l} \textit{neg}, \\ \left[ \begin{array}{l} \textit{subj} \\ \text{PER} \quad 1 \\ \text{NUM} \quad \textit{sg} \end{array} \right] \end{array} \right\} \\ \text{MORPHS} \quad \left\langle \left[ \begin{array}{ll} \text{PH} & \langle \textit{si} \rangle \\ \text{PC} & 1 - 2 \end{array} \right] \right\rangle \end{array} \right]$$

Having established how the extended domain of competition benefits the treatment of preemption across position classes, we shall now address how we integrate cases of extended exponence.

Consider the examples in (10): here, *ha* is clearly the only overt exponent of negation, so we can conclude that it actually expresses negation. In (11), we find extended exponence of negative marking, triggering the presence of *ha* together with a special negative past marker *ku*. However, since we have already established independently *ha* as the expression of negation, and furthermore, since negative past *ku* cannot independently signal negation, it follows that choice of the past marker is merely conditioned by negation.

- (10) a. tu- ta- taka  
 1PL FUT want  
 ‘we will want’  
 b. **ha-** tu- ta- taka  
 NEG 1PL FUT want  
 ‘we will not want’
- (11) a. tu- li- taka  
 1PL PST want  
 ‘we wanted’  
 b. \*(**ha-**) tu- **ku-** taka  
 NEG 1PL PST.NEG want  
 ‘we did not want’

Drawing on our distinction between MUD and MORSYN, we can capture this situation straightforwardly:

- (12) a. 
$$\left[ \begin{array}{l} \text{MUD} \quad \{past\} \\ \text{MORSYN} \quad set \\ \text{MORPHS} \quad \left\langle \begin{array}{l} \text{PH} \quad \langle li \rangle \\ \text{PC} \quad 3 \end{array} \right\rangle \end{array} \right]$$
- b. 
$$\left[ \begin{array}{l} \text{MUD} \quad \{past\} \\ \text{MORSYN} \quad \{neg\} \cup set \\ \text{MORPHS} \quad \left\langle \begin{array}{l} \text{PH} \quad \langle ku \rangle \\ \text{PC} \quad 3 \end{array} \right\rangle \end{array} \right]$$

Because *ku* is merely allomorphically conditioned on negation, it is not a competitor of *ha*, owing to disjoint MUD values. With respect to TAM marking, however, *ku* is a competitor of *li*, given identity of MUD and subsumption of MORSYN specification. Thus, based on a principled distinction between realising a property and being conditioned on some property (Carstairs, 1987), we can actually dispense with rule blocks and extend the scope of Pāṇini’s Principle, without facing problems with extended exponence.

### 3.3 Mari declension (variable morphotactics)

To illustrate how the present account deals with reordering phenomena, let us turn back to the partial paradigm of Mari nouns illustrated in Table 3. This phenomenology is best described by stating that the relative order of case and possessor markers in Mari nominal declension is unconstrained by default; only specific case values call for one or the other order. This can easily be done within the current framework by underspecifying the position index of all possessor and some case affixes, only stating that it has to be higher than that of the stem, here 1. In the accusative (resp. lative), the possessor is forced to occur in position 2 (resp. 3) because the other position is already occupied by the case marker; in the dative, both orders are possible because neither affix is constrained to a specific slot. Arguably such a view is preferable to any view that arbitrarily chooses one relative ordering as basic and takes special measures to authorise reordering in particular instances (cf. e.g. the use of a conditional composition operator in Stump, 2012b).

(13) Variable position affixes

$$\begin{array}{l} \text{a.} \left[ \begin{array}{l} \text{MORPHS} \left\langle \begin{array}{l} \text{PC } 1 + n \\ \text{PH } \langle \text{Ha} \rangle \end{array} \right\rangle \\ \text{MUD} \left\{ \begin{array}{l} \text{POSS} \\ \text{PER } 1 \\ \text{NUM } pl \end{array} \right\} \end{array} \right] \\ \text{b.} \left[ \begin{array}{l} \text{MORPHS} \left\langle \begin{array}{l} \text{PC } 1 + n \\ \text{PH } \langle \text{лаH} \rangle \end{array} \right\rangle \\ \text{MUD} \left\{ \begin{array}{l} \text{CASE } dat \end{array} \right\} \end{array} \right] \end{array}$$

(14) Fixed position affixes

$$\begin{array}{l} \text{a.} \left[ \begin{array}{l} \text{MORPHS} \left\langle \begin{array}{l} \text{PC } 3 \\ \text{PH } \langle \text{M} \rangle \end{array} \right\rangle \\ \text{MUD} \left\{ \begin{array}{l} \text{CASE } acc \end{array} \right\} \end{array} \right] \\ \text{b.} \left[ \begin{array}{l} \text{MORPHS} \left\langle \begin{array}{l} \text{PC } 2 \\ \text{PH } \langle \text{eIII} \rangle \end{array} \right\rangle \\ \text{MUD} \left\{ \begin{array}{l} \text{CASE } lat \end{array} \right\} \end{array} \right] \end{array}$$

## 4 Edge-relative positioning of morphs

In this final section we illustrate how the current approach can deal with Wackernagel affixes. We first present in more detail the Sorani Kurdish data, and then outline an analysis that combines analytic innovations proposed by Crysmann and Bonami (2012) to deal with variable morphotactics with a new position indexing strategy that relies on reified morphs.

### 4.1 The Sorani Kurdish data

We first outline the system of person marking in Sorani Kurdish. Sorani Kurdish possesses two sets of person markers for verbs, which Bonami and Samvelian (2008) call respectively *verbal person endings* (VPEs) and *mobile person markers* (MPMs). The forms of these markers are indicated in table 5. The function of the markers is

	SG	PL		SG	PL
1	-im	-în	1	-im	-mân
2	-î	-in	2	-it	-mân
3	∅	-in	3	-î	-jân
	VPEs			MPMs	

Table 5: The form of Sorani Kurdish person markers

TENSE	SUBJECT AGREEMENT	PRONOMINAL OBJECT
<i>pres</i>	VPE	—
	VPE	MPM
<i>past</i>	VPE	—
	MPM	VPE

Table 6: The distribution of Sorani Kurdish person markers

variable depending on the morphosyntactic context. In present tense, VPEs function as subject agreement markers (15a), whereas MPMs are object pronominal affixes (15b). In past tense, the situation is much more intricate. With strictly intransitive verbs, only VPEs are used, and they function as subject agreement markers (16). With transitive verbs the form-function mapping is reversed: MPMs now function as subject agreement (17a), and VPEs function as object pronominal affixes (17b). The situation is summarised in Table 6.

- (15) a. Bâzîrgân-akân asp-akân da-kir-in.  
 merchant-DEF.PL horse-DEF.PL IPFV-buy.PRS-3PL  
 ‘Narmin is buying the horses.’
- b. Bâzîrgân-akân da=jân=kir-in  
 merchant-DEF.PL IPFV=3PL=buy.PRS-3PL  
 ‘The merchants are buying them.’
- (16) Bâzîrgân-akân hât-in.  
 merchant-DEF.PL arrive.PST-3PL  
 ‘The merchants arrived.’
- (17) a. (Ema) asp-akân=mân kirî.  
 1PL horse-DEF.PL=1PL buy.PST  
 ‘We bought the horses.’
- b. (Ema) kirî=mân=in.  
 1PL buy.PST=1PL=3PL  
 ‘We bought them.’

Turning to morphotactics now, VPEs have a simple distribution: they occur in a fixed position to the right of the stem. MPMs exhibit a much more intricate pattern.

First, they behave as ENDOCLITICS (Harris, 2002). They are always realised on the word at the right edge of the first constituent of the VP (17a). In general, this means being realised as the last morph of that word. If however that word is a verb, then the MPM interacts with verb-internal morphotactics. By default it is the second morph in the word, as evidenced in Table 4. There are however some contexts where the MPM is realised instead in a fixed position to the right of VPEs: if the MPM is 3SG (18a) or if it is plural and cooccurs with a 1SG VPE (18b).<sup>6</sup>

- (18) a. kirî-n-î.  
           buy.PST-3PL=3SG  
           ‘He bought them.’  
       b. kirî-m-tân.  
           buy.PST-1SG=2PL  
           ‘You (pl.) bought me.’

## 4.2 Analysis

Three ingredients are crucial to our account of this dataset.<sup>7</sup>

First, we account for the form-function reversal in the use of the two sets of person markers by appealing to an indirection between argument structure and MORSYN sets, as indicated in Figure 2. We assume that arguments indexed by inflectional morphology are coded in MORSYN using feature structures of two distinct types, *vpe* and *mpm*. The alignment between the representation of indexed arguments in ARG-ST (for the purposes of syntax) and MORSYN (for the purposes of morphology) varies depending on tense and transitivity. Specifically, intransitive verbs associate their sole direct argument with a *vpe* structure in MORSYN. For transitive verbs there are two strategies depending on tense: in the present the subject associates with a *vpe* structure and the object with an *mpm*, while the reverse situation is found in the past.

Second, to account for the default verb-internal positioning of MPMs, we need a way of explicitly making reference to the position of the first realised morph in a word. Crysmann and Bonami (2012) already recognised two indexing schemes for morphs. In *absolute indexing*, morphs are indexed in terms of absolute numbered position. Together with underspecification, this is sufficient to deal with most morph ordering situations, as illustrated above in the case of Mari. As Crysmann and Bonami (2012) show, the morphotactics of the Romance verb motivates the introduction of *stem-relative indexing*: under their analysis, in an Italian verb, the position of pronominal affixes is fixed, the position of the stem is underspecified, and the position of TAM and agreement markers is defined relative to the position of the stem. To this effect, a feature STM is introduced on morphs, that is shared by all morphs in the word:

$$(19) \text{ word} \rightarrow \left[ \text{MORPHS} \left\langle \left[ \text{STM } \boxed{\text{S}} \right], \left[ \text{STM } \boxed{\text{S}} \right], \dots, \left[ \text{STM } \boxed{\text{S}} \right] \right\rangle \right]$$

<sup>6</sup>More fine points of Sorani morphotactics are discussed in Walther (2012).

<sup>7</sup>We focus on realisation of MPMs within the verb. Realisation at a distance can be dealt with using e.g. an edge feature mechanism, and is an issue orthogonal to our current concerns.

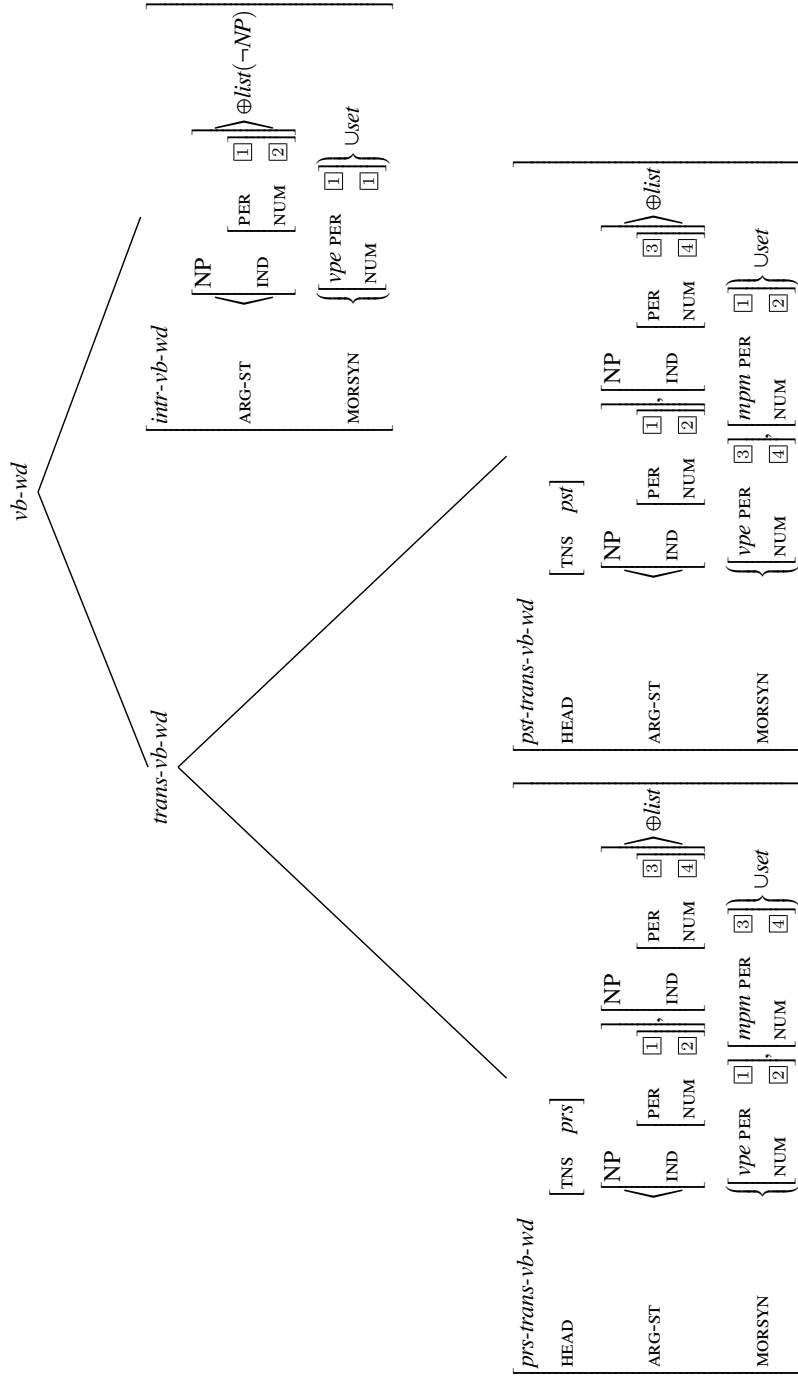

Figure 2: Types of alignment between grammatical functions and person markers



Morphological rules introducing a stem identify their own position index with that of the *STM* feature. Hence the position index of the stem is accessible to all morphs, and particular morphological rules may constrain the exponent they introduce to be realised at some fixed distance from the stem.

A variant of this analytic technique allows us to deal with Wackernagel affixes. We introduce a new feature *1st* that records the position index of the first realised morphs and makes that information available to other morphs (20). Thus a morphological rule for a second position affix such as the schematic rule in (21) will be able to indicate that the morph it introduces has to be adjacent to the first realised morph.

$$(20) \quad \text{word} \rightarrow \left[ \text{MORPHS} \left\langle \left[ \begin{array}{l} \text{1ST} \\ \text{PC} \end{array} \right] \begin{array}{l} \boxed{1} \\ \boxed{1} \end{array} \right\rangle, \left[ \text{1ST} \boxed{1} \right], \dots, \left[ \text{1ST} \boxed{1} \right] \right]$$

$$(21) \quad \left[ \begin{array}{l} \text{MORPHS} \left\langle \left[ \begin{array}{l} \text{1ST} \\ \text{PC} \end{array} \right] \begin{array}{l} \boxed{1} \\ \boxed{1} + 1 \end{array} \right\rangle \\ \text{MUD} \left\{ \left[ \text{mpm} \right] \right\} \end{array} \right]$$

Notice that the formulation of second position placement crucially relies on the use of reified morphs. The current analysis could not be formulated without further stipulations in the a-morphous framework of Crysmann and Bonami (2012): under the set of assumptions that this previous framework shares with other amorphous approaches (Anderson, 1992; Stump, 2001), the rule applying in the most peripheral order need not be a rule that actually introduces an exponent.

The final ingredient to the analysis of Sorani Kurdish person marking is the organisation of the hierarchy of morphological rules in conjunctive dimensions and disjunctive types (Koenig, 1999). Specifically, we assume a cross-classification in two dimensions: MORPHOTACTICS is responsible for the placement of morphs whose phonology is specified in EXPONENCE. Crysmann and Bonami (2012) shows how such a setup allows for the seamless analysis of various variable morphotactic phenomena, including positional disambiguation of person markers in Swahili, conditioned reordering in Fula and Swahili, and mobile stems in Italian. In the present case, the distinction of the two dimensions is crucial to the account of the variable placement of mobile person markers in second or final position. As Figure 3 illustrates, types in the EXPONENCE dimension enumerate the different shapes of MPMs while types in the MORPHOTACTICS list the available positioning strategies documented in Table 4 and examples (18), linking them to appropriate morphosyntactic conditions. As in Koenig (1999), individual combinations of types in conjunctive dimensions need not be listed but can be deduced by so-called online type construction: this is illustrated by the two rules at the bottom of figure 3 corresponding to second position and final placement of the 3PL marker *-jân*. Wherever the distinction between dimension does not allow such factorisation, economy of description is ensured by pre-linking the appropriate type to both dimensions, as is the case here for the rule introducing the 3SG marker *-î*, which uniformly linearises in

final position (18a).

## 5 Conclusion

In this paper we have argued on the basis of complex morphotactic systems for a new model of realisational morphology that is characterised by two central properties: first, an information-based view of morphological completeness and coherence that crucially relies on a distinction of expression (*MUD*) and conditioning (*MORSYN*), enabling us to dispense with stipulated rule blocks altogether and to extend considerably the scope of Pāṇini’s Principle. Second, by moving positional indexing from the rule system into morphological representations, we were able to provide a straightforward account of second position affixes within a much more constrained theory of inflectional morphology which denies morpholexical rules access to the full derivation history, permitting only reference to pivotal positions like that of the stem (for Italian; Crysmann and Bonami, 2012) and the left edge (for Sorani Kurdish).

### A The representation of position class: some further refinements

In the body of this paper, we have assumed, without any further discussion, that position classes can be implemented by means of an integer-valued *pc* feature, together with a global ordering constraint, requiring morphs to be positioned in strictly ascending order. In the context of an HPSG grammar, we may represent natural numbers as lists: 0 is represented by the empty list, and for every number  $n$ ,  $n + 1$  is represented by a list extending the list representing  $n$  by one element. We can then impose the necessary constraints on morph lists by means of the following type declarations:

$$(22) \quad \text{a. } \textit{morph-list} := \textit{list} \wedge [\textit{PREV} \ \textit{list}].$$

$$\text{b. } \textit{ne-morph-list} := \textit{morph-list} \wedge \textit{ne-list} \wedge \left[ \begin{array}{l} \text{FIRST} \left[ \text{PC} \ \boxed{2} (\boxed{1} \oplus \textit{ne-list}) \right] \\ \text{PREV} \ \boxed{1} \\ \text{REST} \left[ \begin{array}{l} \textit{morph-list} \\ \text{PREV} \ \boxed{2} \end{array} \right] \end{array} \right].$$

$$\text{c. } \textit{e-morph-list} := \textit{morph-list} \wedge \textit{e-list}.$$

The formalisation in (22) captures the strict ordering property of morph lists, including slot competition, by means of a local type constraint: as stated in the recursive definition of a non-empty morph list in (22b), the *pc* feature of any morph list element must be longer than the value of the *PREV* feature, which represents the *pc* feature of the previous list item. The length of the current element’s list in turn is registered on the *PREV* value of the list remainder, making the current position class index accessible to the next list element, if any.

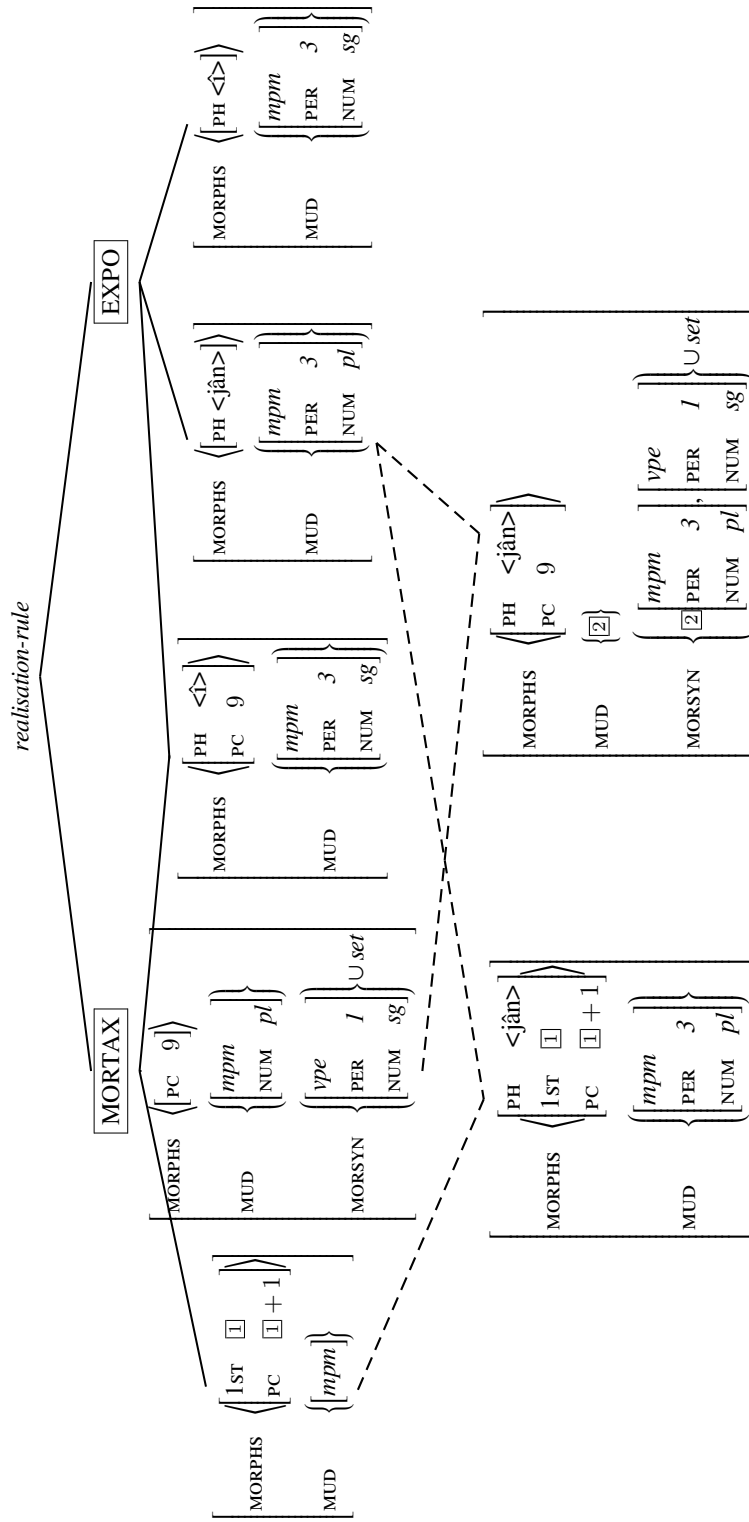

Figure 3: Realisation rules for Sorani Kurdish person markers

While this formalisation is certainly sufficient to deal with the data discussed in this paper, we shall nevertheless propose two refinements to this baseline representation: first, we shall generalise the representation of individual position classes to contiguous spans of position classes, providing a more sound approach to portmanteau morphs, and second, we shall introduce a distinction between distance and direction, thereby facilitating the treatment of ambifixals.

The first extension is rather trivial: instead of representing position classes by means of a single list, all it takes for an implementation of spans is to distinguish between start and end positions, representable as two separate list values. We therefore propose (23) as a replacement for (22b):

$$(23) \quad ne\text{-morph-list} := morph\text{-list} \wedge ne\text{-list} \wedge \left[ \begin{array}{l} \text{FIRST} \quad \left[ \text{PC} \quad \left[ \begin{array}{l} \text{FROM} \quad \boxed{1}(\boxed{0} \oplus list) \\ \text{TO} \quad \boxed{2}(\boxed{1} \oplus ne\text{-list}) \end{array} \right] \right] \\ \text{PREV} \quad \boxed{0} \\ \text{REST} \quad \left[ \begin{array}{l} morph\text{-list} \\ \text{PREV} \quad \boxed{2} \end{array} \right] \end{array} \right].$$

With this first refinement in place, we can assign a positional index to portmanteau position classes, as e.g. in Swahili, without running into arbitrary decisions. Furthermore, a representation of position class built on spans provides a sound basis for slot-based competition that involves a contiguous set of positions, as witnessed, e.g., in Nimboran (Inkelas, 1993).

The second refinement we shall propose concerns the representation of ambifical morphs, that is, morphs are found at a fixed distance from the stem (in terms of position classes), but systematically alternate between a prefixal and a suffixal realisation. Stump (1993) argues that Swahili relative markers and Fula tense and subject agreement are such ambifixals: the main intuition to be captured here is that ambifixals are found at a fixed distance from the stem (in terms of position classes), systematically alternating between a prefixal and a suffixal realisation.

The required level of abstraction from absolute to stem-relative position class can be achieved quite straightforwardly by means of an auxiliary feature *DIST* that is related to absolute position class indices by the following constraints on prefixal and suffixal morphs:

$$(24) \quad pref := aff \wedge \left[ \begin{array}{l} \text{PC} \quad \left[ \text{TO} \quad \boxed{1} \right] \\ \text{DIST} \quad \boxed{2} \\ \text{STM} \quad \left[ \text{FROM} \quad \boxed{1} \oplus \boxed{2} \right] \end{array} \right]. \quad suff := aff \wedge \left[ \begin{array}{l} \text{PC} \quad \left[ \text{FROM} \quad \boxed{1} \oplus \boxed{2} \right] \\ \text{DIST} \quad \boxed{2} \\ \text{STM} \quad \left[ \text{TO} \quad \boxed{1} \right] \end{array} \right].$$

Note that the relative order of prefixes and suffixes on morph lists follows directly from the two constraints above, together with the strict ordering of position class indices imposed by (22) and (23).

In sum, using a single indexing scheme, keyed to certain pivotal positions, we are able to capture a wide range of patterns of variation in position class system,

facilitating abstraction of common properties by means of underspecification.

## References

- Anderson, Stephen R. 1992. *A-Morphous Morphology*. Cambridge: Cambridge University Press.
- Aronoff, Mark and Xu, Zheng. 2010. A realization optimality-theoretic approach to affix order. *Morphology* 20, 388–411.
- Bickel, Balthasar, Banjade, Goma, Gaenzle, Martin, Lieven, Elena, Paudya, Netra Prasad, Rai, Ichchha Purna, Manoj, Rai, Rai, Novel Kishore and Stoll, Sabine. 2007. Free prefix ordering in Chintang. *Language* 83, 43–73.
- Bonami, Olivier and Samvelian, Pollet. 2008. Sorani Kurdish person markers and the typology of agreement, présentation au *Thirteenth International Morphology Meeting*, Vienne.
- Brown, Dunstan and Hippisley, Andrew. 2012. *Network Morphology: a defaults-based theory of word structure*. Cambridge: Cambridge University Press.
- Bybee, Joan L. 1985. *Morphology*. Amsterdam: John Benjamins.
- Carstairs, Andrew. 1987. *Allomorphy in Inflection*. Beckenham, Kent: Croom Helm.
- Crysmann, Berthold. 2002. *Constraint-based Coanalysis*. Ph. D.thesis, Universität des Saarlandes.
- Crysmann, Berthold and Bonami, Olivier. 2012. Establishing order in type-based realisational morphology. In Stefan Müller (ed.), *Proceedings of HPSG 2012*, pages 123–143, Stanford: CSLI publications.
- Harris, Alice C. 2002. *Endoclitics and the Origins of Udi Morphosyntax*. Oxford: Oxford University Press.
- Inkelas, Sharon. 1993. Nimboran Position Class Morphology. *Natural Language and Linguistic Theory* 11, 529–624.
- Koenig, Jean-Pierre. 1999. *Lexical relations*. Stanford: CSLI Publications.
- Lacroix, René. 2009. *Description du dialecte laze d'Arhavi*. Ph. D.thesis, Université Lumière Lyon 2.
- Luís, Ana and Spencer, Andrew. 2005. Paradigm Function Account of 'mesoclis' in European Portuguese. In Geert Booij and Jaap van Marle (eds.), *Yearbook of Morphology 2004*, pages 79–154, Dordrecht: Kluwer.
- Luutonen, Jorma. 1997. *The variation of morpheme order in Mari declension*. Helsinki: Suomalais-ugrilainen Seura.

- Matthews, P. H. 1972. *Inflectional Morphology. A Theoretical Study Based on Aspects of Latin Verb Conjugation*. Cambridge: Cambridge University Press.
- Monachesi, Paola. 1999. *A lexical approach to Italian cliticization*. Stanford: CSLI Publications.
- Nevis, Joel A. and Joseph, Brian D. 1992. Wackernagel affixes: Evidence from Balto-Slavic. In Geert Booij and Jaap van Marle (eds.), *Yearbook of morphology 1992*, pages 93–111, Dordrecht: Kluwer.
- Nordlinger, Rachel. 2010. Verbal morphology in Murrinh-Patha: Evidence for templates. *Morphology* 20, 321–341.
- Noyer, Rolf. 1992. *Features, positions and affixes in autonomous morphological structure*. Ph. D.thesis, MIT.
- Rice, Keren. 2000. *Morpheme Order and Semantic Scope. Word Formation in the Athabaskan Verb*. Cambridge: Cambridge University Press.
- Riese, Timothy, Bradley, Jeremy, Yakimova, Emma and Krylova, Galina. 2010. *Оңай мари́й йылме: A Comprehensive Introduction to the Mari Language*. Department of Finno-Ugric Studies, University of Vienna.
- Samvelian, Pollet. 2007. What Sorani Kurdish Absolute Prepositions Tell Us about Cliticization. In *Texas Linguistics Society IX*, pages 265–285.
- Stump, Gregory T. 1993. Position classes and morphological theory. In Geert E. Booij and Jaap van Marle (eds.), *Yearbook of Morphology 1992*, pages 129–180, Kluwer.
- Stump, Gregory T. 2001. *Inflectional Morphology. A Theory of Paradigm Structure*. Cambridge: Cambridge University Press.
- Stump, Gregory T. 2012a. Overriding default orderings in inflectional morphology, paper presented at the Conference on Defaults in Morphological Theory, University of Kentucky, Lexington, May 21-22, 2012.
- Stump, Gregory T. 2012b. Variable affix order and the amorphousness hypothesis, paper presented at the First American International Morphology Meeting (AIMM), University of Massachusetts, Amherst, September 22, 2012.
- Walther, Géraldine. 2012. Fitting into morphological structure : accounting for Sorani Kurdish endoclitics. In *Proceedings of MMM8*, pages 299–321.

# Word order variation in Khoekhoe

Michael Hahn 

University of Tübingen

Proceedings of the 20th International Conference on  
Head-Driven Phrase Structure Grammar

Freie Universität Berlin

Stefan Müller (Editor)

2013

Stanford, CA: CSLI Publications

pages 48–68

Hahn, Michael. 2013. Word order variation in Khoekhoe. In Stefan Müller (ed.), *Proceedings of the 20th International Conference on Head-Driven Phrase Structure Grammar, Freie Universität Berlin*, 48–68. Stanford, CA: CSLI Publications. DOI: 10.21248/hpsg.2013.3. 

## Abstract

Khoekhoe, a Central Khoisan language, has been claimed to have a clause-second position and topological fields similar to German and Dutch. The position in front of the clause-second position can be occupied by either the matrix verb or a dependent. We argue that monomoraic words are exempt from the general head-final order of Khoekhoe and suggest that this can give rise to discontinuous constituents, where second-position clitics intervene within the VP. We show that this idea provides a simple account of Khoekhoe word order variation and formalize it within a linearization-based HPSG analysis that has a wider scope than the previous Minimalist analyses of Khoekhoe and that is compatible with evidence from tonology.

This paper examines word order variation in Khoekhoe (short for Khoekhoegowab, also known as Nama/Damara), a Central Khoisan language spoken in Namibia and South Africa. It has been claimed to have a clause-second position (den Besten, 2002) and to have topological fields similar to German and Dutch (Witzlack-Makarevich, 2006). There have been three previous generative analyses in GB/Minimalism (Washburn, 2001, den Besten, 2002, Huybregts, 2003). As these analyses seem to be based entirely on descriptive grammars, they are based on a limited amount of data and, while capturing essential aspects of Khoekhoe word order, make some empirical assumptions that turn out to be problematic in the light of corpus data and elicited data. Our goal will be to use new elicited data, supported by corpus data, to give a more complete picture of the empirical situation and then develop a comprehensive analysis, which we will formalize in HPSG.

## 1 Basic Data

### 1.1 SOV Clauses

Khoekhoe is an SOV language (1a).<sup>1</sup> In matrix clauses, one of the clause type markers *ge* (declarative), *kha* (interrogative), *ko/km* (assertive) may appear immediately after the subject. Embedded verbs, stripped of all their non-clitical arguments, the negation marker *tama*, and pronominal object clitics attach to the verb, forming what we will call the *verbal complex*. The linearization of the elements between the clause type marker and the verbal complex is largely free. In (1a), all six permutations of these elements are grammatical (e.g., 1b–d). By analogy

---

<sup>†</sup>I want to thank Berthold Crysmann, Stefan Müller, two anonymous reviewers, and the audience of HPSG 2013 for their helpful comments. Most of all, I thank Gerson Topnaar for sharing his language with me. Of course, I alone am responsible for all errors.

<sup>1</sup>The transliteration largely follows the official transliteration as given in Haacke & Eiseb (2002), with two differences in vowel marking: First, long vowels, including nasalized ones, are marked by reduplication. Second, epenthetic vowels are omitted, following the analyses of Hagman (1977) and Brugman (2009). As in the official transliteration, tone is omitted.



to Germanic, we will refer to the collection of these elements as the *Middlefield*, following Witzlack-Makarevich (2006):

- (1)
- |    |       |      |           |           |          |         |
|----|-------|------|-----------|-----------|----------|---------|
| a. | taras | (ge) | ari       | ‡khanis-a | go       | maa=te  |
|    | woman | DECL | yesterday | book-A    | TAM      | give=me |
| b. | taras | (ge) | ‡khanisa  | ari       | go       | maa=te  |
| c. | taras | (ge) | ari       | go        | ‡khanisa | maa=te  |
| d. | taras | (ge) | go        | ari       | ‡khanisa | maa=te  |
- ‘the woman gave me a book yesterday’

As these examples show, complement NPs are realized as full noun phrases with the case marker *-a* (glossed A) or as a pronominal clitic in the verbal complex. A subject may be realized by a full NP as in (1), or by an enclitic Person-Gender-Number (PGN) marker appearing in the normal subject position (2a). In the latter case, a coreferent case-marked NP may appear in the middlefield (2b):

- (2) a. tsî=s ge ||ari ‡khanis-a go maa=te  
and=3fs DECL yesterday book-A TAM give=me  
‘and she gave me a book yesterday’
- b. tsî=s ge ||ari taras-a ‡khanis-a go maa=te  
and=3fs DECL yesterday woman-A book-A TAM give=me  
‘and the woman gave me a book yesterday’

With respect to case marking and word order, this NP behaves largely like a complement (cf. Haacke (1978) for an extensive discussion). We will assume that it is indeed a complement introduced by a lexical rule and will not consider it further here.

The subject PGN marker is a clitic rather than an affix, as it does not seem to show any morphophonological idiosyncrasies (Zwicky & Pullum, 1983), and may attach to any element preceding the subject position, even if it does not belong to the same clause. In particular, it may appear at the beginning of embedded clauses:

- (3) tsî=[b |gôab-a !narigau] hîa=gu ge ||îga go !gûû<sup>2</sup>  
and=3MS boy-A drive while=3mp DECL they.A TAM go  
‘and while the boy was driving, they left’

As it apparently can have wide scope over VP coordination only if the subject is the same in both VPs, we analyze the PGN marker as a subject pronoun, not an agreement marker.

---

<sup>2</sup>Witzlack-Makarevich (2006, 57)

## 1.2 Fronting

If the subject is realized by a clitic only, a complement (4a), an adjunct (4b), or the verbal complex itself (4c) may precede it. In declaratives, there may be at most one such element (5). The subject position cannot be occupied by a lexical NP in this case (6):

(4)	<i>Prefield</i>		<i>Middlefield</i>	
	a. †khanis-a	=s ge go	ari	maa=te
		book-A 3fs DECL TAM	yesterday	give=me
	b.   ari	=s ge go	†khanis-a	maa=te
	c. maa=te	=s ge go	ari †khanis-a	

‘she gave me a book yesterday’

(5) \* †khanis-a maa=te=s ge go ||ari  
 book-A give=me=3FS DECL TAM yesterday  
 intended: ‘she gave me a book yesterday’

(6) \* †khanis-a taras ge go ||ari maa=te  
 book-A woman DECL TAM yesterday give=me  
 intended: ‘the woman gave me a book yesterday’

Again by analogy with Germanic V2, we refer to the preposed element as the *Prefield* and refer to the occurrence of an element in the prefield as *fronting*. The position of the subject clitic and the clause type marker has been interpreted as a clause-second position by den Besten (2002) and Witzlack-Makarevich (2006).

The verbal complex can be fronted as a whole, while it is impossible to front only parts of the verbal complex. While the prefield may contain at most one element in declaratives, it may contain several elements in interrogative and hortative clauses (7). Any collection of elements that could occur alone in the prefield appears to be allowed. If the verbal complex is fronted, it is the last element of the prefield (7 d–e):

(7)		<i>Prefield</i>		<i>Middlefield</i>	
	a. tarasa	†khanisa	maa =b	go   ari?	
		woman	book give =3MS	TAM	yesterday
	b. tarasa	†khanisa	=b	go   ari	maa?
	c. †khanisa	tarasa	=b	go   ari	maa?
	d. * tarasa	maa	†khanisa =b	go   ari?	
	e. * maa	tarasa	†khanisa =b	go   ari?	

‘did he give the woman a book yesterday?’

The clause type marker *kha* may appear between any two prefield elements (e.g., 8), while it may never appear in the middlefield.

- (8) taras-a kha maa=ts go †khanis-a †ari?  
 woman-A INTERROG give=2MS TAM book-A yesterday  
 ‘did you give the woman a book yesterday?’

Previous work mentions multiple fronting only in the case where there is a clitic-left-dislocated subject and the last fronted element is the verbal complex (Hagman, 1977, 144). Indeed, this is by far the most common pattern, but there is corpus data supporting the more inclusive judgments in (7). Multiple fronting without a dislocated subject is attested at least if the subject is in the first or second person.<sup>3</sup> Possibly, multiple fronting requires the subject to be topical. In any case, it seems that the requirement of a dislocated subject is a matter of discourse constraints, not of grammaticality. Multiple fronting where the last element is not the verbal complex is indeed very rare and we have only been able to find a handful of corpus examples.<sup>4</sup>

## 2 More Data

**TAM Markers** Kheokhoe TAM markers fall into two classes with differing word order possibilities: monomoraic TAM markers (*a, ga, ge, go, nî, ra*), and multimoraic markers (*tide, ii, hââ*). In the examples above, all TAM markers were monomoraic. Monomoraic TAM markers often immediately precede the verbal complex, but they can also be placed further to the left within the middlefield (1c–d).<sup>5</sup> They may also occur immediately after the verbal complex.<sup>6</sup> Thus, monomoraic TAM markers may occur anywhere from the beginning of the middlefield to the position following the verbal complex, subject to certain usage preferences. On the other hand, multimoraic markers are always placed after the verbal complex:

- (9) a. *namas ge taras-a maa tide*  
 Nama(f.) DECL woman-A give TAM+NEG

<sup>3</sup>E.g., [xuu’e] kha [xare] [!gûûs ââts !nââ] [daa-khâi]=ts go – thing-A INTERROG ADV journey your on hurry=2ms TAM ‘did you hurry on your journey?’ (Krönlein, 1889, 47)

<sup>4</sup>E.g., [!gararo-e] [xawe’e]=ts kha uu-hâ tama hâ sa |goan xa – remainder-A ADV=2MS INTERROG have not TAM your cattle of ‘do you not even have a small remainder of your cattle?’ (Krönlein, 1889, 93)

<sup>5</sup>This is not mentioned by the descriptive grammars. Examples are given by Haacke (1999), Witzlack-Makarevich (2006), and Brugman (2009, 244). While this is mainly found in embedded clauses, it is attested in main clauses at least in older data and in Witzlack-Makarevich (2006)’s data from the Richtersveld dialect.

<sup>6</sup>This is again not mentioned by the descriptive grammars. Examples are given by Klein (1976, 215) and Haacke (1999, 191, S14-S17a). There is also a small amount of corpus data, e.g. *hoo-hoo=te=ts ge o=ta kom hoolââ go=o* – warn=me=2MS TAM CONJ=1S ASSERT find.out TAM=ASSERT ‘after you had warned me, I found out (about it)’ (Krönlein, 1889, 109). Our consultant apparently only accepts this pattern if the TAM marker is not sentence-final.

- b. \* *namas ge taras-a tide maa*  
 Nama(f.) DECL woman-A TAM+NEG give  
 ‘the Nama will not give (anything) to the woman’

There are also multiple, potentially discontinuous TAM markers, such as *go...a* in the following example:<sup>7</sup>

- (10) *tsuuse=ta ra tsâa [tiita go ||ari a mîiba=tsi] !khais !aroma*<sup>8</sup>  
 painful=1S TAM feel I TAM yesterday TAM tell=you thing because  
 ‘I feel bad because of the thing I told you about yesterday’

**Other Dislocation Patterns** There is an apparent second fronting strategy, where the verb is fronted together with the TAM markers and optionally some complements and adjuncts, while others may be realized in the middlefield (Hagman, 1977, 111). The subject position may be occupied by a full NP in this case. Its prosodic behavior (Haacke, 1999, Brugman, 2009) and a close parallelism to copulative clauses suggest that this structure is treated best as a fossilized cleft construction where the fronted elements form a constituent modifying the subject, together with which they occupy the prefield. We will not treat this structure here.

Further to the left of the prefield, there may appear dislocated NPs that are coreferent with a pronoun in the subsequent part of the clause. This fronting strategy seems to be an instance of clitic left dislocation and will not concern us further here. Apart from the local fronting of *wh*-phrases into the prefield, there is no *wh*-extraction in Khoekhoe.

**Tonology** Khoekhoe is a tone language (Haacke, 1999). Tone is determined lexically, but the lexical tone melodies are replaced in a predictable way in certain syntactic environments by sandhi melodies. While a formal analysis of tone is beyond the scope of this paper, tone should be considered in any syntactic analysis, as the plausibility of syntactic analyses can be measured by the simplicity of the rules necessary for describing the interaction between syntax and tonology.

For every basic tonal melody, there is an associated sandhi melody (Haacke, 1976, Haacke, 1999). Informally, sandhi patterns generally occur on a word when the word is a noninitial daughter. The pattern is most transparent in NPs and PPs, where, in the simplest case, every noninitial dependent and the phrase-final head

<sup>7</sup>While combinations of a monomoraic marker with multimoraic markers such as *ge...ii* and combinations of the form *gV-rV* are well known, other combinations of monomoraic markers have been documented by Witzlack-Makarevich (2006, 21) for Richtersveld Nama and by Haacke (2013, 346) for !Gora, who links the *a* occurring here with the juncture morpheme of Kalahari Khoe. (10) is an example from written Namibian Khoekhoegowab.

<sup>8</sup>|Uriseb (1993, 4)

show sandhi tone (Haacke, 1976). As the tones inside NPs and PPs are determined entirely by the NP/PP-internal structure, and adverbs and particles do not change their tone (Brugman, 2009, 169), the syntactic constructions that concern us here only affect the tone of TAM markers and the matrix verb. Their tonal behavior, as described by Haacke (1999) and Brugman (2009), has two important ramifications for our concerns. First, it may be suggested that the fronted elements in (7a–c) form a partial VP, which would be fronted as a constituent – similar to the analysis of German multiple fronting by Müller (2002b, 2013). However, as the verb would be the last constituent of the fronted partial VP, it would then be expected to carry sandhi tone in multiple fronting, which it does not (Haacke, 1999). Thus, tonology suggests that the fronted elements in multiple fronting do not form a constituent. Second, it suggests that the verbal complex forms a constituent with TAM markers: while the verb shows sandhi tone if it follows the TAM marker, it usually shows citation tone if it is followed by a TAM marker (Haacke, 1999, 189, Brugman, 2009, 261).<sup>9</sup> These considerations will play a role in the formal details of our analysis.

### 3 Analysis

#### 3.1 Previous work

Word order variation in Khoekhoe has previously been studied in GB and Minimalism by Washburn (2001), den Besten (2002), and Huybregts (2003). They all agree that fronting arises from movement out of the canonical position. The highest (overtly filled) head is an element that resists preposing and under the analyses is a complementizer: the clause type marker in the analyses of Washburn (2001) and den Besten (2002), and the subject clitic according to Huybregts (2003).

The three analyses seem to rely entirely on descriptive grammars, which has the unfortunate consequence that they sometimes make incorrect empirical assumptions. For instance, the presentation in Hagman's descriptive grammar (1977) suggests that TAM markers are always adjacent to the verbal complex unless it is fronted. In Washburn (2001)'s analysis, where TAM markers occupy the T position, this empirical assumption motivates the claim that complements are not overtly realized in the maximal projection of the verb, which then motivates the fact that declaratives do not allow multiple fronting (5). However, the empirical claim, while correctly expressing a general tendency, is falsified by (1c–d). Thus, there is no motivation for the ungrammaticality of (5).

Huybregts is mainly concerned with explaining a presumed pattern where the TAM marker is shifted to the beginning of the middlefield when the verbal complex is fronted. Again, this pattern actually reflects a usage preference, not a grammati-

---

<sup>9</sup>Verbs only show sandhi tone if there is a clause type marker (Brugman, 2009, 256). We assume that this rule has to be stipulated and does not follow from constituent structure.

cality contrast. Besides the empirical problems, the two analyses have gaps that are not trivial to fill. For instance, Washburn only accounts for declaratives, leaving open how (7) can be accounted for. Den Besten (2002) considers more (though only positive) data, which results in a far more comprehensive empirical picture. However, the analysis is rather informal and it is left open which mechanisms precisely generate the grammatical structures and how clauses like (5) are excluded (den Besten, 2002, 38).

### 3.2 Fronting as Extraction

The basic idea of the previous analyses, i.e. that fronting is an instance of dislocation and that clauses without a filled prefield are ‘more basic’, seems very reasonable. From a more theory-neutral point of view, one may take the Subject – Middlefield – Verbal Complex sequence as the basic word order, and allow elements that would appear behind the subject in the basic order to appear in front of the subject clitic, with the syntactic structure and the linearization of the remainder remaining invariant.

The difficulty arises that fronting applies equally to the verb and its dependents. In the GB/Minimalist accounts, this is no problem, as there are intermediate heads: T and C in den Besten’s analysis, and many more in the Minimalist analyses. As these positions are filled by overt elements that indeed resist preposing, namely the TAM marker, the clause type marker, or the subject, the analysis appears to be well-motivated. However, as the following set of examples shows, none of the candidate heads is necessary for fronting to be allowed: a nonreferential subject clitic, the clause type marker, and the TAM marker can be omitted:

(11)		<i>Prefield</i>							
a.	[+hanu	tama]	=’i	kom	hââ	[ gâus	ai]	=o	
	be.right	NEG	=3NS	ASSERT	TAM	home	in	=ASSERT	
b.	[+hanu	tama]	=’i	kom		[ gâus	ai]	=o	
c.	[+hanu	tama]		kom		[ gâus	ai]	=o	
d.	[+hanu	tama]	=’i			[ gâus	ai]		
e.	[+hanu	tama]				[ gâus	ai]		

‘Something is not good at home (a-c, e) / Is something not good at home? (d)’

Under an analysis along the lines suggested above, a uniform analysis of fronting can only be achieved by using empty elements, or by some other way of mimicking the effect of an empty head. Depending on one’s convictions, one may either take this as evidence for empty elements, or as evidence that there might be better analyses. As we are not aware of any other phenomenon of Khoekhoe which would provide an independent motivation for empty clause type markers, TAM markers, or subject clitics, we take this as a motivation to look for alternatives.

### 3.3 Linearization-based Analysis

Descriptively, fronting seems to be purely a matter of constituent order and information structure. There are no known concomitant morphosyntactic effects, we are not aware of differences in semantic interpretation, and there is no particular reason to link fronting to differences in constituent structures. This suggests that one might look for a linearization-based analysis which models fronting as variation in linearization without variation in constituent structure.

Brugman (2009) observes that some of the constraints on the linearization of subject clitics and clause type markers follow from the fact that they consist of at most one mora. In her analysis, mono-moraic words are not prosodic words in Khoekhoe, and hence cannot appear in initial positions. In fact, monomoraic words more generally tend to show unexpected word order patterns in Khoekhoe, when compared to their multimoraic counterparts, which usually show head-final order: PPs and CPs are head-final, the verb usually follows complements and adjuncts, and NPs are generally head-final. The contrast between mono- and multimoraic elements is particularly clear in the case of complements: prosodically autonomous non-extrapolated complements generally precede the verb, while object clitics follow the verb (1).

This is somewhat parallel to the contrast between monomoraic and multimoraic TAM markers discussed above. We suggest that TAM markers are always heads selecting a verbal complex. Monomoraic words, not being prosodic words, are exempt from the general head-final word order. Thus, both the free placement of the monomoraic markers and the obligatory postverbal position of bimoraic TAM markers, which would require additional stipulations if TAM markers were treated as complements or via a construction, follow automatically. The same treatment may be applied to the unexpected word order properties of the subject clitics and clause type markers, which are also monomoraic: they attach to a saturated projection of a verb or a TAM marker, but may be realized within the VP, which thus becomes discontinuous and encompasses both the prefield and the middlefield. This immediately explains why both the predicate and its dependents can appear in the prefield, as the prefield is simply the first part of the discontinuous VP. It also explains why fronting is impossible if the subject position is filled by a lexical NP, as lexical NPs are multimoraic and hence obey strict head-final word order and cannot intervene in another phrase. This treatment is compatible with the fact that the placement of subjects and clause type markers elements is sensitive to the *number* of elements in the prefield, but insensitive to their syntactic categories.

None of these facts appears to be motivated so easily by the extraction-based analyses. Thus, it seems that a more adequate analysis of Khoekhoe word order can be provided on the basis of the claim that Khoekhoe is a head-final language, but that fronted constituents and monomoraic words are exempt from this constraint and that their deviant linearization behavior may give rise to discontinuous constituents. In the next section, we will formalize such an analysis.

## 4 Formalization

The intuition of discontinuous constituents can be formalized elegantly in Domain-based HPSG (Reape, 1994). Every sign is assigned a *domain* encoded in the DOM list, whose elements are of type *dom-obj*. The phonology of a phrase is computed not from the phonologies of the daughters, but from the phonologies of the domain elements:

$$(12) \quad \text{sign} \rightarrow \left[ \begin{array}{l} \text{PHON} \quad \boxed{1} \oplus \dots \oplus \boxed{n} \\ \text{DOM} \quad \left\langle \left[ \text{PHON} \quad \boxed{1} \right], \dots, \left[ \text{PHON} \quad \boxed{n} \right] \right\rangle \end{array} \right]$$

Phrases differ as to how their domain is computed from the domains of their daughters (Kathol & Pollard, 1995, Donohue & Sag, 1999): *Compacting* phrases fuse the daughter's domains into a single domain element, while *Liberating* phrases take all domain elements of the daughters into their domain. Using liberating phrases, domain structure can be dissociated from constituent structure.

$$(13) \quad \begin{array}{l} \text{a. } \textit{liberating-phrase} \rightarrow \left[ \begin{array}{l} \text{DOM} \quad \boxed{1} \circ \dots \circ \boxed{n} \\ \text{DTRS} \quad \left\langle \left[ \text{DOM} \quad \boxed{1} \right], \dots, \left[ \text{DOM} \quad \boxed{n} \right] \right\rangle \end{array} \right] \\ \text{b. } \textit{compacting-phrase} \rightarrow \left[ \begin{array}{l} \text{DOM} \quad \left\langle \left[ \text{DOM} \quad \boxed{1} \circ \dots \circ \boxed{n} \right] \right\rangle \\ \text{DTRS} \quad \left\langle \left[ \text{DOM} \quad \boxed{1} \right], \dots, \left[ \text{DOM} \quad \boxed{n} \right] \right\rangle \end{array} \right] \end{array}$$

In Khoekhoe, the verbal complex, noun phrases, and postpositional phrases are compacting, while higher projections of the verbal complex and of TAM markers are liberating. For the purposes of our analysis, domains that only allow permutation within maximal projections, as used by Müller (1999), would also provide a viable option. Word order is described by the interaction of constituent structure with linearization constraints. We will first discuss the constituent structure of Khoekhoe clauses, and then define appropriate linearization constraints.

### 4.1 Constituent Structure

**Verb Phrase** For the VP, several constituent structures have been proposed for languages that show a similar degree of free word order. It may be flat (Kasper, 1994), binary branching, or have an intermediate structure where arguments are realized in a flat structure, while adjuncts adjoin at higher levels. We choose a binary branching structure, as it avoids technical complications of the other options and readily accounts for simple coordination phenomena. The verbal complex and the VP are built up recursively by *head-comp-phrase* and the *head-adj-phrase*:



$$(14) \left[ \begin{array}{l} \textit{head-comp-phrase} \\ \text{SYNSEM|LOC|CAT|COMPS} \quad \boxed{1} \oplus \boxed{3} \\ \text{HEAD-DTR|S|L|CAT|COMPS} \quad \boxed{1} \oplus \langle \boxed{2} \rangle \oplus \boxed{3} \\ \text{NON-HEAD-DTRS} \quad \langle \boxed{[\text{SYNSEM } \boxed{2}] \rangle} \end{array} \right] \left[ \begin{array}{l} \textit{head-adj-phrase} \\ \text{HEAD-DTR|SYNSEM} \quad \boxed{1} \\ \text{NON-HEAD-DTRS} \quad \langle \boxed{[\dots|\text{MOD } \boxed{1}] \rangle} \end{array} \right]$$

Note that the verb can combine with its complements in any order, which accounts for the free word order within the middlefield Müller (2013, To Appear).

**Verbal complex** Verbal complex formation is enforced by a boolean-valued feature LEX (Müller, 2002a, 87). The analysis of the Khoekhoe verbal complex is simple: Unlike, for instance, German, Khoekhoe only allows clitics and verbs to appear in the verb complex, and none of these elements can be realized outside of the verbal complex. Therefore, we can simply assume that every sub-constituent of the verbal complex is LEX +, while all higher constituents are LEX -. Clitics occurring in the verbal complex and PGN markers are lexically specified as LEX +. Raising verbs select a predicative complement marked as LEX +. NPs, adverbs, and other constituents that cannot occur in the verbal complex are specified as LEX - in the syntax or lexically. We now postulate that a phrase is LEX - if and only if one of the daughters is LEX -, and that non-head-daughters of LEX - phrases are LEX -. This suffices to predict verbal complex formation, without requiring a special phrasal type like Müller (2008)'s *head-cluster-structure*. To account for linearization, we cross-classify *head-comp-phrase* with *liberating* and *compacting* and state that a *head-comp-phrase* is liberating if and only if it is LEX -.

**TAM, Clause Type markers, and Subjects** As we have noted above, tonology suggests that TAM markers form a constituent with the verbal complex. Thus, we analyze them as heads selecting a LEX + verb projection and taking over its argument requirements (15 left). As TAM markers are not part of the verbal complex, they are LEX -. We leave open how multiple TAM marking is analyzed, possibly, there is only one TAM marker which has multiple domain objects. Subjects are realized in a *spr-head-phrase* (15 right), which is also liberating. This phrase is used both for lexical and for clitical subjects.

$$(15) \left[ \begin{array}{l} \text{SPR} \quad \boxed{1} \\ \text{COMPS} \quad \left\langle V \left[ \begin{array}{l} \text{LEX} \quad + \\ \text{SPR} \quad \boxed{1} \\ \text{COMPS} \quad \boxed{2} \end{array} \right] \right\rangle \oplus \boxed{2} \\ \text{LEX} \quad - \end{array} \right] \left[ \begin{array}{l} \textit{spr-head-phrase} \\ \text{SYNSEM|LOC|CAT|COMPS} \quad \langle \rangle \\ \text{HEAD-DTR|S|L|CAT|SPR} \quad \langle \boxed{1} \rangle \\ \text{NON-HEAD-DTRS} \quad \langle \boxed{[\text{SYNSEM } \boxed{2}] \rangle} \end{array} \right]$$

Clause type markers are markers in the sense of Pollard & Sag (1994), attaching to saturated clauses. Via constraints on the marking value of clauses, one may

easily express the generalizations that clause type markers are optional, cannot be iterated, and are only allowed in matrix clauses. Prosodic constraints account for the facts that they cannot appear clause-initially (Brugman, 2009, 241) and cannot occur between the prefield and the subject.

Thus, the constituent structure we assume for the Khoekhoe clause is fairly standard: there is a binary-branching VP, in which complements and adjuncts may be realized in any order, TAM markers behave like raising verbs, and subjects and markers attach at a higher level. Semantic composition can proceed by the usual mechanisms and no extra stipulations are needed for clauses with fronting. The structure is essentially what an HPSG adaptation of the structure assumed by the GB/Minimalist analyses for clauses without fronting could look like. The major difference between the analyses is the mechanism used for fronting: While the Minimalist analyses assume that there is movement, we assume that clauses with fronting only differ in linearization, but not in constituent structure.

**Example Analysis I** Consider the basic examples in (2a–4) again. If we simplify the sentences by removing the NP complement for a moment, we arrive at (16a–d). For each sentence, it is also (at least marginally) possible to put *go* to the end (e.g., 16e).

(16)		<i>Prefield</i>		<i>Middlefield</i>		
	a. (tsîi)	=s	ge	ari	go	maa=te
	and	=3fs	DECL	yesterday	TAM	give=1s
	b. (tsîi)	ari	=s	ge	go	maa=te
	c. (tsîi)	maa=te	=s	ge	go	ari
	d. (tsîi)	=s	ge	go	ari	maa=te
	e. (tsîi)	=s	ge		ari	maa=te go

‘(And) she gave me (something) yesterday’

All these sentences have the same constituent structure, which is shown in Figure 1. The VP, represented by an *head-adj-phrase*, consists of a verbal complex, a TAM marker, and an adjunct. The clause type marker and the enclitic subject pronoun attach at higher levels.

If the VP contains multiple dependents, the question arises in which order they attach. We will show below that they can be assumed to attach in the order in which they appear on the surface.

## 4.2 Constraining Linearization

The DOM list of the clause will contain all elements that can be permuted: the verbal complex, middlefield and prefield constituents, subject, and TAM markers.

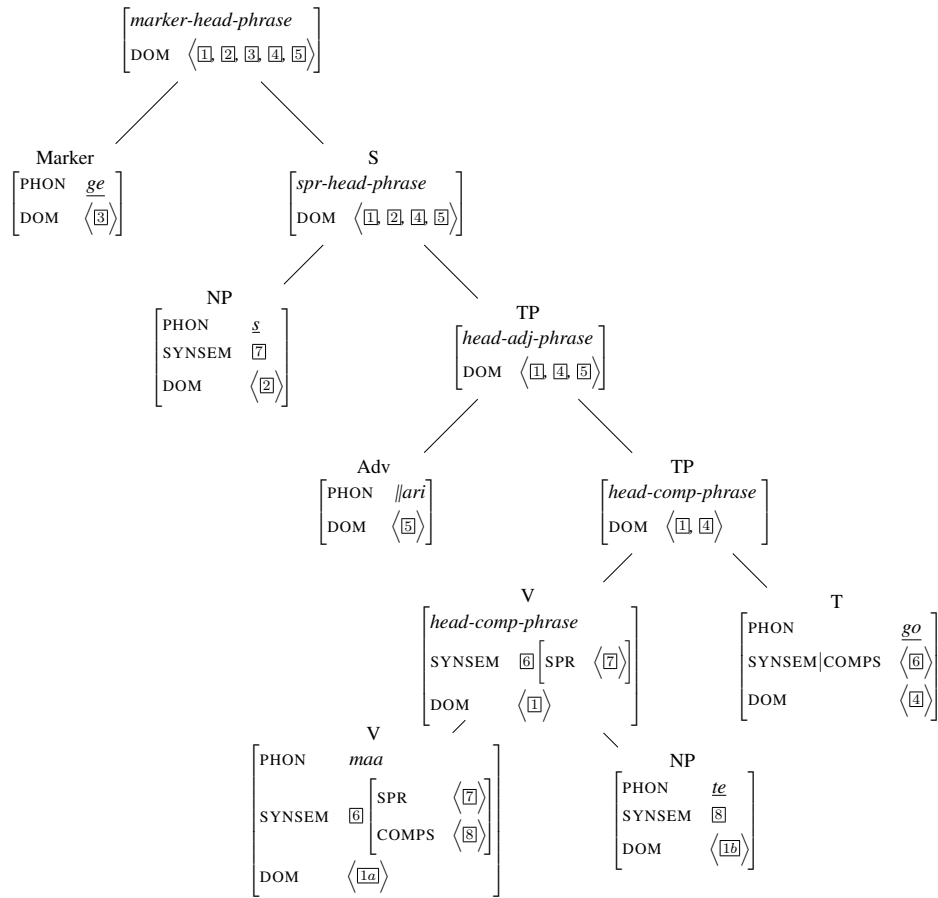

Figure 1: Analysis of (16). Clitics and monomoraic words are underlined.

Linear precedence rules will now restrict their relative ordering. We add a boolean-valued feature `FRONTED` appropriate for *dom-obj* that has the value `+` if and only if the sign is fronted. The members of the prefield and the subject count as fronted, while the elements following the subject are not fronted.

We can now formalize our generalization that, in the absence of monomoraic words, or fronting of the verbal complex, phrases are head-final. The following constraint appears to model this intuition:

(17) Head-Final Constraint (Preliminary Version)

$$\left[ \begin{array}{l} \text{HEAD-DTR} \quad \langle 2 \rangle \left[ \begin{array}{l} \text{FRONTED} \quad - \\ \text{PHON} \quad \textit{multimoraic} \end{array} \right] \\ \text{NON-HEAD-DTRS} \quad \langle 1 \rangle \left[ \text{PHON} \quad \textit{multimoraic} \right] \end{array} \right] \rightarrow \langle 1 \rangle < \langle 2 \rangle$$

It states that, if the head is not fronted and both the head and the dependent are multimoraic, a phrase is head-final. However, the constraint prescribes a relative ordering of the daughters, while it should be possible to shuffle the domains of the daughters. We therefore need a more general statement which quantifies over all domain elements of the daughters:

(18) Head-Final Constraint (Final Version)

$$\left( \begin{array}{l} \text{HD-DTR} \quad \left[ \text{DOM} \left\langle \dots \boxed{2} \left[ \begin{array}{l} \text{FRONTED} \quad \boxed{3} \\ \text{PHON} \quad \textit{multimoraic} \end{array} \right] \dots \right\rangle \right] \\ \text{N-HD-DTRS} \quad \left\langle \dots \left[ \text{DOM} \left\langle \dots \boxed{1} \left[ \begin{array}{l} \text{FRONTED} \quad \boxed{4} \\ \text{PHON} \quad \textit{multimoraic} \end{array} \right] \dots \right\rangle \dots \right\rangle \right] \\ \text{DOM} \quad \boxed{5} \\ \wedge \boxed{3} \rightarrow \boxed{4} \\ \rightarrow \text{precede}(\boxed{5}, \boxed{1}, \boxed{2}) \end{array} \right)$$

where  $\text{precede}(\boxed{5}, \boxed{1}, \boxed{2})$  is true if and only if all occurrences of  $\boxed{1}$  precede all occurrences of  $\boxed{2}$  in the domain structure in  $\boxed{5}$ . Here,  $\rightarrow$  is the usual implication relation between the *boolean* truth values  $-$  and  $+$ :  $\boxed{1} \rightarrow \boxed{2}$  is true if and only if either  $\boxed{1} = -$ , or  $\boxed{1} = \boxed{2} = +$ . Thus, this constraint is more general in a second respect: it also applies when *both* selected domain elements are fronted. This becomes important in multiple fronting, where the verb, if it is fronted, is the last fronted element.

If both elements are non-fronted and multimoraic, the constraint says that the element from the head daughter precedes the element from the non-head daughter. In an utterance in which all phrases are headed and unary or binary, in which all words are multimoraic, and in which there is no fronting, this constraint enforces that all constituents are continuous and head-final, since the elements of the non-head daughter's domain will always precede those of the head daughter.

The constraint predicts that a non-fronted verbal complex follows the middlefield and that multimoraic TAM markers follow the VP. It also predicts that lexical subjects are incompatible with a nonempty prefield (6): Since all lexical roots are multimoraic in Khoekhoe (Brugman, 2009), neither a non-clitical subject nor an element of the prefield other than the clause-type marker can be mono-moraic. Thus, by (18), the domain object of the subject will precede all domain objects contributed by the VP.

If there are monomoraic or fronted elements, their linearization is not constrained by (18) and discontinuities may arise. The linearization of these elements is governed by (19):

- (19) a. [FRONTED +] < [FRONTED –]  
 b. In a *spr-head-phrase*: [FRONTED +] ≤ Specifier  
 c. [HEAD *marker*] ≤ [FRONTED –]  
 d. [HEAD *tam-marker*] → [FRONTED –]

Fronted elements always precede non-fronted elements (19a), and the subject is the last fronted element (19b). This ensures that the prefield does not extend to the right of the subject clitic. The clause type marker precedes all (other) non-fronted elements (19c), but its FRONTED value and its position relative to the fronted elements are not constrained, allowing it to appear within the prefield or after the subject. Note that we use ≤ rather than <, as the specifier itself is also fronted. TAM markers are always non-fronted (19d). Monomoraic TAM markers may appear in any position that allows non-fronted elements, i.e. in the middlefield and after the verbal complex. Multi-moraic TAM markers are forced by (18) to appear after the middlefield and the verbal complex (9).

**Constraining Multiple Fronting** There is an additional constraint stipulating that at most one element may be fronted in declaratives (5), which may be stated as follows:

$$(20) \left[ \begin{array}{l} \dots \text{HEAD} \left[ \begin{array}{l} \textit{verb} \\ \text{CLAUSE-TYPE} \textit{ decl} \end{array} \right] \\ \text{DOM} \langle \textit{dom-obj} \rangle \oplus \mathbb{1} \end{array} \right] \rightarrow \mathbb{1} \left( \begin{array}{l} \text{list} \left( \left[ \text{PHON} \textit{ prosodic-non-word} \right] \right) \\ \oplus \text{list} \left( \left[ \text{FRONTED} \textit{ -} \right] \right) \end{array} \right)$$

Together with (18), it excludes clauses such as (5). It might be considered preferable if this generalization somehow arose from the fronting mechanism. But the fact that it holds only for declaratives and that there are no other known differences between fronting in declaratives and interrogatives/hortatives suggests that this should not be expected. Rather, multiple fronting can be understood simply as one of the ways the language distinguishes non-declarative clauses from declarative ones, for which there is no general mechanism such as a question marker or inverted word order.

**Example Analysis I** Let us now examine how these linearization constraints work together to produce the linearizations in (16) for the constituent structure in Figure 1. By (19), the subject is FRONTED + and the TAM marker is FRONTED –. By (19a), the subject therefore precedes the TAM marker. The linearization of the remainder depends on which elements are FRONTED +. If neither the verbal complex nor the adverb is FRONTED +, they both follow the subject. As they are multimoraic, constraint (18) applies to the *head-adj-phrase* and forces the adjunct to appear in front of the verbal complex. On the other hand, the position of the

monomoraic TAM marker is not restricted by this constraint, and (16c–e) are licensed. By (19c), the clause type marker must appear to the left of these elements. As the clause type marker cannot appear to the left of the subject by prosodic constraints, it can only be placed immediately after the subject.

If, say, the verbal complex is *FRONTED +*, it precedes all other elements by (19a). Constraint (18) does not apply, and the head-initial ordering is licensed. Similarly, if the adverb is *FRONTED +*, orderings such as the one in (16b) result.

**Example Analysis II: Multiple Fronting** In the previous example, the verb had only one non-clitical dependent. Let us now see what happens if there are several dependents, as in the following example with a ditransitive and multiple fronting:

- (21) taras-a kha maa=ts go †khanis-a ‖ari?  
 woman-A INTERROG give=2MS TAM book-A yesterday  
 ‘did you give the woman a book yesterday?’

The VP contains a verb, an adverb, and two argument NPs. The verb and one complement are fronted. The clause type marker and the enclitic subject pronoun attach at higher levels, but again are linearized within the VP. This sentence has the syntactic structure in Figure 2. The difference to Figure 1 is that the VP is more complex and contains two complements in addition to an adjunct. The order in which these attach to the verb directly mirrors the order in which they are linearized. This is also the only possible analysis. To see this, suppose that, say, the complement †*khanisa* and the adjunct ‖*ari* were interchanged in the tree. Then there is an *head-adj-phrase* combining the adjunct (‖*ari*) with the constituent formed by the complement (†*khanisa*), the TAM marker, and the verb (*maa*), where the latter daughter is the head. Now if ① is the complement and ② the adjunct, constraint (18) applies to the *head-adj-phrase* and forces the adjunct to precede the complement, different from the ordering in (21). As the constraint in (18) targets all domain elements of the head, it also applies if the verb is fronted, which means that there is only one analysis even if the verb is fronted. Thus, the use of word order domains does not lead to spurious ambiguities such as those that have been noted for domain-based analyses of German word order (Müller, 2008, 152).

## 5 Discussion

In Section 3.3, we claimed that a linearization-based analysis provides a simple description of the data which directly motivates patterns that are not predicted by the previous movement-based accounts. The phrasal types and lexical entries are very simple and essentially identical to ones that have been previously proposed for other languages. The mechanism of word-order domains has been successful crosslinguistically, and we only used the basic distinction between liberating

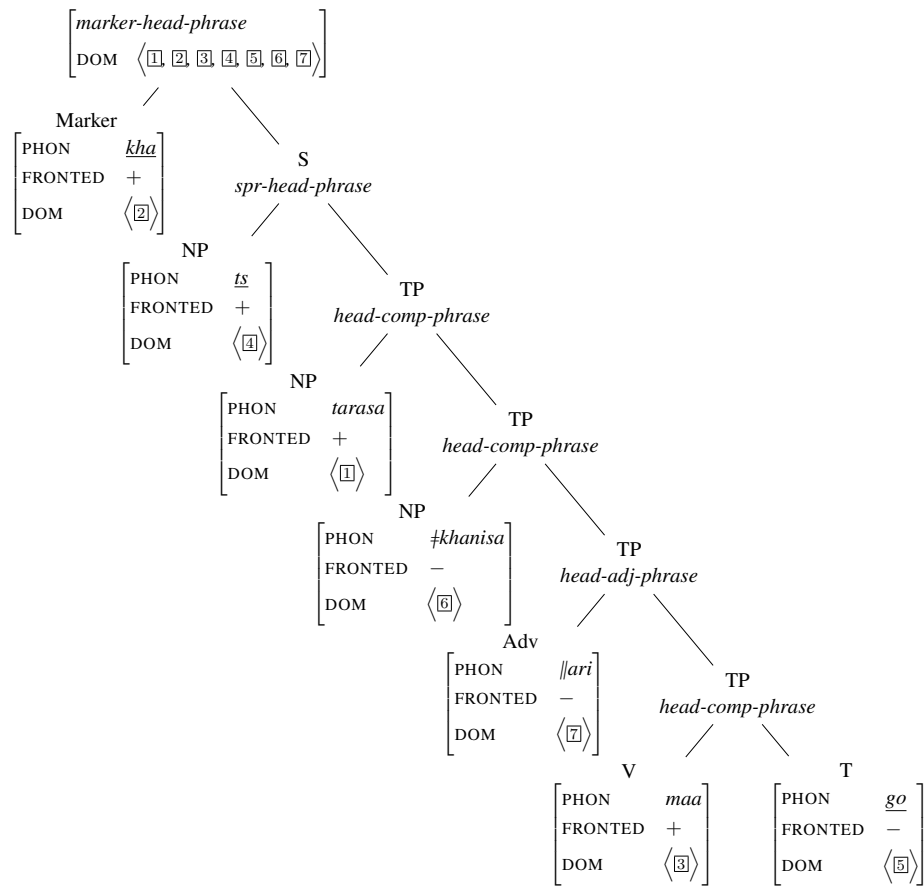

Figure 2: Analysis of (21). The domain objects are numbered by their linear order. Note that, for multimoraic non-heads, linear order coincides with the order of realization in the tree.

and compacting phrases. The only complex language-specific constraints are the Head-Final Principle (18), which we motivated independently in Section 3.3, and the constraint on multiple fronting (20), which is simply one of the mechanisms Khoekhoe uses for marking clause type.

It can also be noted that, assuming that Khoekhoe words receive sandhi tone whenever they are a noninitial daughter and stipulating Haacke’s rule of ‘Relative Retention’, our analysis of constituent structure correctly predicts the tone sandhi data in Haacke (1999, Chapter 4). Some of the additional data in Brugman (2009) is not explained, but it appears likely that some additional rules need to be stipulated in any case. The previous analyses did not consider tone and do not have a sufficient coverage to test them on all of Haacke’s data, but it is in principle also compatible with extraction-based analyses.

Our analysis is somewhat similar to the cross-linguistic account of V2 proposed by Wetta (2011), who defines an attribute *LIN* appropriate for *sign* with values *flexible* and *fixed*. *Fixed* elements are those whose position is determined constructionally, such as the verb in V2 clauses. Linearization constraints such as those acting on a ‘middlefield’ will typically affect flexible elements without interfering with fixed elements. This feature can be identified with our *FRONTED* attribute. As Khoekhoe does not have V2, our linearization constraints are quite different from Wetta’s, but our analysis confirms the applicability of his general approach.

**Alternatives without Domains or Extraction** One might analyze fronting via a local extraction mechanism that is applicable to both the head of the clause and its dependents, uniting local extraction and head movement. The difficulty with this is that such an account requires a mechanism that works for both heads and their dependents, which to our knowledge has not yet been proposed in the HPSG literature. It seems preferable to use a cross-linguistically well-motivated mechanism rather than a mechanism designed for a single language.

One might also assume that fronting arises from the ability of verbs to realize their dependents in different orders, as has been suggested in HPSG for German verb placement (Crysmann, 2004). Such an approach faces difficulties when the verb appears in the prefield (4c), as the relative order of subject, clause type marker, and middlefield remains invariant, while it would be expected to be reversed. Note that the fact that TAM markers are probably heads is irrelevant, as the availability of fronting of the verbal complex does not depend on their presence. Furthermore, there are word order rules applying to the middlefield that appear to be unaffected by fronting, in particular the discontinuous TAM markers. In such an analysis, these rules would have to be stipulated either via linearization domains, in which case both complex variation in constituent structure and linearization domains are required for the analysis of the same phenomenon, or locally by some otherwise unmotivated book-keeping mechanism.

A further alternative is a completely flat structure, in which fronting can be described as permutation of sister nodes, as in the analyses assumed by Haacke (1978). Besides the verb, complements and adjuncts, this structure would also contain the subject and the clause type marker. However, such an analysis requires significant formal machinery to model the possible configurations. Such an analysis can be seen as a notational variant of our analysis in which the realization of dependents is regulated not by simple rules operating on larger binary-branching structures, but by complex rules operating on simple phrase structures.

**The Postfield** It is possible for one or more adjuncts or complements to occur after the verbal complex (Hagman, 1977, 113). This may be taken as evidence that the verbal complex is part of the middlefield, which would then extend to the right, and that verb placement is free. This appears to agree well with the fact that TAM



markers may appear postverbally. However, it seems that postverbal elements are always instances of extraposition. First, it is impossible for a postverbal element to intervene between the verb and a postverbal TAM marker. Second, Khoekhoe has an unbounded dependency extraposition pattern for arguments where there is a pronoun at the canonical position (cf. Haacke (1992) for a comprehensive discussion). Such extraposed elements may intervene between the verbal complex and a postverbal argument (22a), but may not occur in front of the verbal complex (22b).

- (22) a. taras ge go maa=gu<sub>i</sub> [|naa khoega]<sub>i</sub> [Petrub go xoa  
 woman DECL TAM give=them those men-A Petrus TAM write  
 ‡khanisa]  
 book-A  
 ‘the woman gave those men the book Petrus wrote’
- b. \* taras ge go [|naa khoega]<sub>i</sub> maa=gu<sub>i</sub> [Petrub go xoa  
 woman DECL TAM those men-A give=them Petrus TAM write  
 ‡khanisa]  
 book-A  
 ‘the woman gave those men the book Petrus wrote’

Thus, we assume that the rightmost position for TAM markers is the position immediately following the (non-fronted) verbal complex, while arguments and adjuncts may be extraposed with or without a pronoun in the canonical position.

## 6 Conclusion

Khoekhoe allows local fronting of both predicates and complements/adjuncts. We showed that this can be analyzed as a discontinuity of the VP, which is interrupted by monomoraic words attaching at a higher level. More generally, we showed that monomoraic words are exempt from the general head-final order of Khoekhoe and argued that they can give rise to discontinuous constituents. We provided a formal HPSG analysis, showing how Khoekhoe word order variation can be analyzed without empty elements based on mechanisms that have previously been proposed for other languages. The analysis has a significantly wider empirical scope than the previous Minimalist analyses of Khoekhoe clause structure.

## References

- den Besten, Hans. 2002. Khoekhoe syntax and its implications for L2 acquisition of Dutch and Afrikaans. *Journal of Germanic Linguistics* 14.1. 3 – 56.
- Brugman, Johanna Christina. 2009. *Segments, tones and distribution in Khoekhoe prosody*: Cornell University dissertation.

- Crysmann, Berthold. 2004. On the efficient implementation of German verb placement in HPSG. In *Proceedings of RANLP 2003*, 112 – 116.
- Donohue, Cathryn & Ivan A. Sag. 1999. Domains in Warlpiri. In *Sixth international conference on HPSG – Abstracts*, 101–106. Edinburgh.
- Haacke, Wilfrid H. G. 1976. *A Nama grammar: the noun-phrase*. University of Cape Town MA thesis.
- Haacke, Wilfrid H. G. 1978. *Subject deposition in Nama*. Colchester University of Essex MA thesis.
- Haacke, Wilfrid H. G. 1992. Dislocated noun phrases in Khoekhoe (Nama/Damara): further evidence for the sentential hypothesis. *Afrikanistische Arbeitspapiere* 29. 149–162.
- Haacke, Wilfrid H. G. 1999. *The tonology of Khoekhoe (Nama/Damara) Quellen zur Khoisan-Forschung*. Köppe.
- Haacke, Wilfrid H. G. 2013. Syntax: Namibian Khoekkhoe, !Gora. In Rainer Vossen (ed.), *The Khoesan languages*, 325–346. Routledge.
- Haacke, Wilfrid H. G. & Eliphaz Eiseb. 2002. *A Khoekhoegowab dictionary with an English-Khoekhoegowab index*. Gamsberg Macmillan.
- Hagman, R.S. 1977. *Nama Hottentot grammar*, vol. 15. Indiana University Bloomington.
- Huybregts, Riny. 2003. A PF-interface condition on syntactic computation. In Jan Koster & Henk van Riemsdijk (eds.), *Germania et alia: A linguistic webschrift for Hans den Besten*, . <http://www.let.rug.nl/koster/DenBesten/contents.htm>.
- Kasper, Robert T. 1994. Adjuncts in the mittelfeld. In John Nerbonne, Klaus Netter & Carl J. Pollard (eds.), *German in Head-Driven Phrase Structure Grammar* (CSLI Lecture Notes 46), 39–69. Stanford University: CSLI Publications.
- Kathol, Andreas & Carl Pollard. 1995. Extraposition via complex domain formation. In *Proceedings of the 33rd annual meeting of the association for computational linguistics*, 174 – 180.
- Klein, Harriet E. M. 1976. Tense and aspect in the Damara verbal system. *African Studies* 35. 207–227.
- Krönlein, Johann Georg. 1889. *Wortschatz der Khoi-Khoin*. Berlin: Deutsche Kolonialgesellschaft.
- Müller, Stefan. 1999. *Deutsche Syntax deklarativ. Head-Driven Phrase Structure Grammar für das Deutsche* (Linguistische Arbeiten 394). Tübingen: Max Niemeyer Verlag.

- Müller, Stefan. 2002a. *Complex predicates: Verbal complexes, resultative constructions, and particle verbs in German* (Studies in Constraint-Based Lexicalism 13). Stanford: CSLI Publications.
- Müller, Stefan. 2002b. Multiple frontings in German. In Gerhard Jäger, Paola Monachesi, Gerald Penn & Shuly Winter (eds.), *Proceedings of formal grammar 2002*, 113–124. Trento.
- Müller, Stefan. 2008. *Head-Driven Phrase Structure Grammar: Eine Einführung* (Stauffenburg Einführungen 17). Tübingen: Stauffenburg Verlag 2nd edn.
- Müller, Stefan. 2013. German sentence structure: An analysis with special consideration of so-called multiple frontings. Manuscript, <http://hpsg.fu-berlin.de/~stefan/Pub/gs.html>.
- Müller, Stefan. To Appear. HPSG – A Synopsis. In Artemis Alexiadou & Tibor Kiss (eds.), *Syntax – Ein internationales Handbuch zeitgenössischer Forschung* Handbücher zur Sprach- und Kommunikationswissenschaft, Berlin: Walter de Gruyter Verlag 2nd edn.
- Pollard, Carl & Ivan A. Sag. 1994. *Head-Driven Phrase Structure Grammar*. Chicago: University of Chicago Press.
- Reape, Mike. 1994. Domain union and word order variation in German. In John Nerbonne, Klaus Netter & Carl J. Pollard (eds.), *German in Head-Driven Phrase Structure Grammar* (CSLI Lecture Notes 46), 151–197. Stanford University: CSLI Publications.
- |Uriseb, A. 1993. *||Hûisa !nubu ||gae#hâadi*. Windhoek: Gamsberg Macmillan.
- Washburn, P. 2001. A Minimalist approach to Khoekhoe declaratives. *Cornell Working Papers in Linguistics* 18. 28–56.
- Wetta, Andrew C. 2011. A construction-based cross-linguistic analysis of V2 word order. In Stefan Müller (ed.), *The Proceedings of the 18th International Conference on Head-Driven Phrase Structure Grammar*, 248–268. Stanford: CSLI Publications.
- Witzlack-Makarevich, Alena. 2006. *Aspects of Information Structure in Richtersveld Nama*. Universität Leipzig MA thesis.
- Zwicky, Arnold M. & Geoffrey K. Pullum. 1983. Clitization vs. Inflection: English n't. *Language* (59). 502–513.

# Nonverbal predicates in Modern Hebrew

Petter Haugereid 

University of Bergen  
The Open University of Israel  
University of Haifa

Nurit Melnik 

The Open University of Israel

Shuly Wintner 

University of Haifa

Proceedings of the 20th International Conference on  
Head-Driven Phrase Structure Grammar

Freie Universität Berlin

Stefan Müller (Editor)

2013

Stanford, CA: CSLI Publications

pages 69–89

Haugereid, Petter, Nurit Melnik & Shuly Wintner. 2013. Nonverbal predicates in Modern Hebrew. In Stefan Müller (ed.), *Proceedings of the 20th International Conference on Head-Driven Phrase Structure Grammar, Freie Universität Berlin*, 69–89. Stanford, CA: CSLI Publications. DOI: 10.21248/hpsg.2013.4. 

## Abstract

Nonverbal predicates in Modern Hebrew (MH) have been the subject of investigation in a number of studies. However, to our knowledge, none of them was corpus-based. Corpus searches reveal that the nonverbal constructions which are most commonly addressed in the literature are not the most commonly used ones. Once a broader range of data is considered additional issues are raised. Our analysis addresses these issues, unifying the treatment of three types of copular constructions that we identify in MH. The analysis is implemented as part of a larger-scale grammar, and is extensively tested.

## 1 Introduction

This paper contributes to the longstanding discussion of nonverbal predicates and the copula. Our starting point is a corpus investigation of this phenomenon in Modern Hebrew (MH).<sup>1</sup> Although nonverbal predicates in MH have been the subject of investigation in a number of studies (e.g., Doron 1983; Falk 2004; Greenberg 2008), to our knowledge, none of the existing studies have conducted a corpus investigation. We will show that an empirical corpus-based examination of this phenomenon reveals patterns which have not been previously considered yet which should be taken into account when proposing a comprehensive analysis.

The standard data items that illustrate these constructions in the literature are:

- (1) a. dani (hu) more/nexmad  
dani (he) teacher.SM/nice.SM  
'Dani is a teacher/nice.'
- b. ha-yeladim (hem) al ha-gag  
the-kids (they.M) on the-roof  
'The kids are on the roof.'

Here, the predicates consist of NPs (1a), AdjPs (1a), and PPs (1b). The copula linking the subject and the predicate is homonymous with 3rd person pronouns (hence the gloss) and agrees with the subject. The pronominal forms of the copula are only used in present tense, and they are sometimes optional. In past and future tense an inflected form of the verb *haya* 'be' is obligatorily used. The present tense form of *haya* is missing from the MH inflectional paradigm.

- (2) a. dina hayta mora/nexmada  
dina was.3SF teacher.SF/nice.SF  
'Dina was a teacher/nice.'
- b. dani ve-dina yihiyu morim/nexmadim  
danny and-dina will.be.3P teachers.PM/nice.PM  
'Danny and Dina will be teachers/nice.'

---

<sup>†</sup>This research was supported by THE ISRAEL SCIENCE FOUNDATION (grant No. 505/11).

<sup>1</sup>For this study we use a 60-million token WaCky corpus of Hebrew (Baroni et al., 2009).

In what follows we will refer to the present tense copula as ‘Pron’ to distinguish it from the past and future tense forms of *haya*.

The sentences above constitute the prototypical examples of the copular construction, as is reflected by the majority of the papers that address this construction (in MH as well as in other languages). The subject in most data items is an animate NP. Less frequent subjects are concrete nouns (e.g., *The books are on the table.*). Yet it is particularly rare to find abstract nouns as subjects. Nevertheless, corpus searches<sup>2</sup> reveal that abstract nouns are in fact more frequent, and, perhaps more importantly, exhibit additional properties which are often overlooked when only animate nouns are examined.

One such property is the use of two additional types of predicates: infinitival VPs and finite clauses. These are illustrated in (3)–(4).

- (3) ha-matara hi lehenot.  
the-goal.3SF she to.enjoy  
‘The goal is to have fun.’
- (4) ha-matara hi she-dani yehene.  
the-goal.3SF she that-dani will.enjoy  
‘The goal is that Dani will have fun.’

These types of predicates are absent from the literature on copular constructions in MH, yet seem to belong to the same category as the more commonly discussed constructions above. In the following section we will investigate the syntactic properties of all types of nonverbal constructions in MH.

## 2 Syntactic Properties of Nonverbal Constructions in MH

In this section we will focus on a number of syntactic properties of the constructions, which will ultimately be accounted for in the proposed analysis. More specifically, we will address the issues of subject-predicate agreement, word order alternations, unbounded dependency constructions, and the categorial identity of Pron.

### 2.1 Agreement Patterns

Among the different nonverbal predicates identified in MH, the only relevant ones to consider in terms of subject-predicate agreement are NPs and AdjPs, since both nouns and adjectives in MH are specified for number and gender. Animate nouns are inflected for natural gender and number. Inanimate and abstract nouns have grammatical gender. Adjectives obligatorily agree with whatever they modify; attributive adjectives agree with the nominal head in an NP and predicative adjectives with their subjects (cf. (1a) & (2)).

---

<sup>2</sup>For the English data, The BYU British National Corpus was used (Davies, 2004-).

The agreement patterns between NP subjects and NP predicates are not as straightforward as those with AdjP predicates. When the NP predicate is an animate noun that has a full number-gender inflectional paradigm the two NPs exhibit full agreement.

- (5) a. ha-more hu sporta'i  
the-teacher.SM he athlete.SM  
b. ha-mora hi sporta'it  
the-teacher.SF she athlete.SF  
'The teacher is an athlete.'
- (6) a. ha-morim hem sporta'im  
the-teachers.PM they.M athletes.PM  
b. ha-morot hen sporta'iyot  
the-teacher.PF they.F athletes.PF  
'The teachers are athletes.'

With inanimate nouns, which are marked with grammatical gender, gender agreement is irrelevant. Thus in (7) below the masculine subject appears with a feminine predicate. Number, however, does play a role with singular concrete nouns, as singular NP subjects are incompatible with plural NP predicates.

- (7) ha-sefer hu matana/\*matanot  
the-book.SM he gift.SF/gifts.PF  
'The book is a gift.'

There are, however, examples of number mismatches when abstract nouns are involved. In (8), a singular NP subject appears with a plural NP predicate.

- (8) ha-hesber ha-yexidi le-nicxono hu ha-havtaxot  
the-explanation.SM the-single.SM to-his.victory he the-promises.PF  
ha-mafligot she-hu natan le-boxarav  
the-overarching.PF that-he gave to-his.voters  
'The only explanation for his victory is the over-arching promises that he gave his voters.'

Furthermore, with plural subjects the cardinality of the NP predicate encodes a collective vs. distributive distinction, where singular predicates produce a collective reading (9a), and plural predicates a distributive one (9b).

- (9) a. ha-sfarim ha-'ele hem matana mi-axi  
the-books.PM the-these.PM they.M present.SF from-my.brother  
'These books are a present from my brother.'
- b. ha-sfarim ha-'ele hem matanot mi-xaverai  
the-books.PM the-these.PM they.M presents.PF from-my.friends  
'These books are presents from my friends.'

As the English translations of these example sentences indicate, these number agreement patterns are similar in the two languages.

## 2.2 Word Order Alternations

The unmarked word order of clauses in MH is SVO, and this applies to clauses with nonverbal predicates as well. Nevertheless, a number of word order alternations were attested in the corpus. In one such alternation, exemplified by (10), Pron follows the predicate.

- (10) shtei ha-yecirot makbilot hen mi-bxinat ha-mivne  
 two the-pieces.PF parallel.PF they.F from-aspect the-structure  
 ‘The two pieces are parallel in terms of their structure.’

Moreover, there are attested examples of predicate-initial constructions (aka inverse copular constructions), where Pron optionally appears between the predicate and the subject (11a).<sup>3</sup> However, no occurrences of predicate-initial and Pron-final clauses (Pred-S-Pron) were attested (cf. (11b)).

- (11) a. me’atim (hem) ha-nos’im ha-ma’asikim et ha-siyax  
 few.PM (they.M) the-topics.PM the-occupying.PM ACC the-discourse  
 ha-ciburi  
 the-public  
 ‘Few are the topics which occupy the public discourse.’  
 b. \* me’atim ha-nos’im hem  
 few.PM the-topics.PM they.M  
 Intended meaning: ‘The topics are few.’

Finally, one position where Pron does not occur is clause-initially, regardless of the relative ordering of the subject and predicate.

## 2.3 Unbounded Dependency Constructions

“Extraction” from clauses with nonverbal predicates is possible with subjects and predicates. When predicates are extracted Pron can optionally appear (12). When subjects are extracted Pron is absent (13).

- (12) a. eifo (hu) ha-oto?  
 where the-car  
 ‘Where is the car?’  
 b. adayin lo barur ma (hi) ha-siba  
 still NEG clear what (she) the-reason.PF  
 ‘It is still not clear what is the reason.’

<sup>3</sup>It appears that the “weight” of the subject NP plays a role in the licensing of this construction.



- (13) mi (\*hu) ayef?  
 who he tired.SM  
 ‘Who is tired?’

When subjects of nonverbal predicates are relativized the relativizer *she-* ‘that’ is prefixed to the predicate, an AdjP in the following example. Similarly to subject wh-questions, Pron cannot occur in this construction.

- (14) zehu sug ha-mahalaxim she-ofyaniyim lo  
 this-he type the-moves.PM that-typical.PM to-him  
 ‘This is the type of moves which are typical of him.’

## 2.4 What is Pron?

Pron is identical in form to 3rd person personal pronouns and it obligatorily agrees in number and gender with the subject. Nevertheless, we assume that it is not a pronoun. First, Pron is not assigned a semantic role. Second, it can be used as a copula in a construction where the subject is a personal pronoun (15) and the person features of the two elements are mismatched.

- (15) ani hu ha-manhig  
 I he the-leader  
 ‘I am the leader.’

Third, the wh-words *ma* ‘what’ and *mi* ‘who’ have variants that are inflected for number and gender. Inflected wh-forms are used only in the present tense copular construction (cf. (16b) & (17b)), while the pronoun in the periphrastic form can be either Pron or a pronoun (cf. (16a) & (17a)).

- (16) a. ma hi ha-be’aya?  
 what she the-problem.SF  
 b. mahi ha-be’aya?  
 what-she the-problem.SF  
 ‘What is the problem?’

- (17) a. ma hi amra?  
 what she said.3SF  
 b. \*mahi amra?  
 what-she said.3SF  
 ‘What did she say?’

The cliticized form of Pron can also appear with the demonstrative *ze*, while personal pronouns cannot.

(18) zehu axi  
 this-he axi  
 'This is my brother.'

(19) \* zehu  
 this-he  
 'It's him.'

Nevertheless, Pron cannot be classified as a clitic since there are no adjacency requirements between it and the subject or predicate. Adverbs can be placed in the two positions.

- (20) a. ha-seret hu be'ecem ma'agali lexalutin  
 the-movie.SM he actually circular.SM completely  
 'The movie is actually completely circular.'  
 b. kol ha-mishkal be'ecem hu ba-beten  
 all the-weight.SM actually he in.the-stomach  
 'All the weight is actually in the stomach.'

The similar function of present tense Pron and past/future tense *haya* 'be' suggests that Pron may be a type of a verb. However, as Doron (1983) notes, the distribution of Pron is distinct from verbs in general, and *haya* in particular. For example, V2-like constructions occur in MH with 'real' verbs (21), but not with Pron (22).

- (21) a. hayom Dani roce banana  
 today Dani wants.SM banana  
 b. hayom roce Dani banana  
 today wants.SM Dani banana  
 'Today, Danny wants a banana.'

- (22) a. hayom Dani hu more  
 today Dani he teacher  
 b. \* hayom hu Dani more  
 today he Dani more  
 'Today, Danny is a teacher.'

An additional distinction involves the placement of the negative *lo*:

- (23) a. Dani lo roce banana  
 dani NEG wants.SM banana  
 'Danny doesn't want a banana.'  
 b. Dani lo haya more  
 dani NEG was.3SM teacher  
 'Danny wasn't a teacher.'

- (24) Dani hu lo more  
 dani he NEG teacher  
 ‘Danny isn’t a teacher.’

Moreover, in subject extraction constructions such as (13) and (14) above, where Pron is not licensed, the inflected forms of *haya* appear in past and future tense.

To summarize, the types of predicates involved, the agreement patterns between subjects and predicates, the word order alternations, and the categorial identity of Pron and its apparent optionality, are all issues which need to be addressed when proposing an account of the data. In what follows we first review previous HPSG-based analyses of copular constructions and then present our proposal.

### 3 Nonverbal Constructions in HPSG

#### 3.1 The Role of the Copula

The ‘canonical’ HPSG analysis of nonverbal predicate constructions views the copula as a type of a subject raising verb that structure-shares the subject requirement of its predicative complement, and combines with the subject to realize this requirement and form a clause. Importantly, in this analysis the copula does not contribute to the semantics of the clause. These properties are captured in the abbreviated description of the copula *be* (Pollard & Sag, 1994, 147).

- (25) 
$$\left[ \begin{array}{l} \text{CAT} \mid \text{SUBCAT} \left\langle \left[ \text{NP}, \text{XP} \left[ +\text{PRD}, \text{SUBCAT} \left\langle \left[ \text{NP} \right] \right] \right] \right] \right\rangle \right. \\ \left. \text{CONTENT} \left[ \text{NP} \right] \right]$$

This approach to the construction requires that nonverbal predicates select for NP subjects and be marked as +PRD. To this end, a lexical rule takes as input a ‘regular’ noun lexeme and outputs a predicative noun with a non-empty SUBCAT list (Pollard & Sag 1994; Ginzburg & Sag 2000). The motivation for identifying predicational phrases as such extends beyond the copular construction, since the same class of predicates have a similar distribution (Pollard & Sag, 1987, page 66).

This analysis adequately accounts for the constructions commonly considered in the literature. Nevertheless, when more data and other languages are investigated the analysis faces some problems.

Van Eynde (2008) raises a number of arguments against the lexical rule analysis. He objects to the systematic ambiguity which the noun rule introduces. Moreover, he provides evidence against a raising analysis which identifies the subject of the copula with the subject of the predicate. One such case is the infinitival VP predicate, such as illustrated in (3) above. The unexpressed subject of the VP ‘to enjoy’ has arbitrary reference which cannot be equated with the subject of the clause ‘the goal’. This observation holds for the MH data above, its English translation, and the Dutch examples given by Van Eynde (2008). Moreover, when clausal

predicates are involved (e.g., (4)) no unexpressed subject exists, since the subject of the clausal predicate is realized within the predicate itself.

Van Eynde (2008; 2009; 2012) proposes a Montagovian treatment of predicative complements, which shifts the burden from the predicate to the copula (or the selecting verb). According to his analysis, the copula is not devoid of semantic content. Rather, the semantic link between the subject and the predicate is captured in the lexical entry of the copula.

$$(26) \left[ \begin{array}{l} \text{PHON} \langle be \rangle \\ \text{ARG-ST} \langle \text{NP}_{[1]}, \text{XP}_{[2]} \rangle \\ \text{SS} \mid \text{LOC} \mid \text{CONTENT} \mid \text{NUCLEUS} \left[ \begin{array}{ll} \textit{be-rel} & \\ \text{THEME} & [1] \textit{index} \\ \text{ATTRIBUTE} & [2] \textit{index} \end{array} \right] \end{array} \right]$$

One argument for the necessity of ascribing semantic content to the copula comes from the assignment of the EXPERIENCER role in sentences such as *This book is too expensive for me*. If the copula is semantically vacuous, Van Eynde asks, what assigns the EXPERIENCER role to the PP *for me*?

### 3.2 Copula Omission

While Van Eynde places the burden of the licensing of the construction on the copula, MH as well as other languages allow its omission in certain contexts. Although Van Eynde (2009, 368) argues that this “is not by itself an argument for semantic vacuity” the (sometimes optional) omission of a copula is a challenge to an analysis in any framework. In the HPSG framework phonologically empty elements are generally avoided. Nevertheless, several accounts of copular constructions in a variety of languages do assume empty elements.

Bender (2001) proposes a “silent verb analysis” to account for copula absence in African American Vernacular English (AAVE). Her argument is based on complement extraction. When the predicative phrase is extracted in copula-less clauses (e.g., *Where your car?*) there needs to be a place to register the extraction site. This, she argues, can be done either by reintroducing traces or by the use of a silent copula. Both solutions require the stipulation of phonologically empty elements.

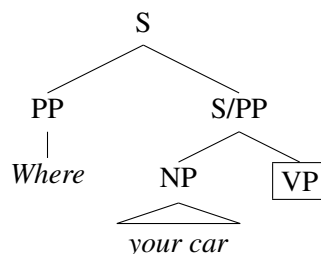

Figure 1: Bender’s analysis of copula absence in AAVE

Müller (2002; to appear) argues that in certain constructions the use of empty elements is advantageous. One such case is the omission of the copula in declarative sentences in German, where assuming a phonologically empty copula preserves the topological fields. Moreover, he demonstrates that the avoidance of empty elements may lead to the stipulation of additional rules and schemata, as well as a linguistically less insightful grammar.

A construction-based analysis of zero copula is proposed by Henri & Abeillé (2007) for the copular construction in Mauritian. They show that the Mauritian copula does not behave like the AAVE copula. Its realization or omission are construction-dependent, as the copula appears only in extraction contexts. This particular behavior, they argue, lends itself well to a construction-based analysis. Moreover, they conclude that a null form analysis is warranted only in cases where the distribution of the copula and zero copula are not complementary.

## 4 An Analysis of MH Nonverbal Predicates

The analysis we propose provides a unified account of the three types of constructions identified for MH: the present tense construction, with and without Pron, and the past/future construction with verb-like inflected *haya* ‘be’. It accounts for the entire range of nonverbal predicates of MH: NP, AdjP, PP, AdvP, VPinf, and S.

Similarly to Van Eynde (2008; 2009; 2012), we propose that nonverbal constructions do not involve raising. While raising requires identity between the subject of the copula and the subject of the predicate, this is not the case with infinitival VPs or clauses (e.g., (3), (4)). In addition, a raising construction is not compatible with cases of agreement mismatches, such as in (7) above.

Moreover, contrary to ‘standard’ HPSG analyses, we concur with Van Eynde in assuming that the semantic content of the copula is not vacuous. Rather, its function is to link the subject and the predicate. Nevertheless, unlike Van Eynde’s analysis, ours does not require all predicates to be of type *scope-object*. Predicates are linked to the subject by the *copula-rel* depending on their type.

Finally, we assume the existence of a phonologically empty Pron element which shares the syntactic and semantic properties of the overt Pron and the verbal *haya* ‘be’. In doing so we can account for cases of complement extraction, which were shown by Bender (2001) (for AAVE) to require the stipulation of an empty element. Moreover, this approach enables us to provide a unified account of the three constructions and to “capture the facts in an insightful way”, in the words of Müller (to appear, page 103).

### 4.1 Grammar Design

The grammar we design makes a distinction between the parse tree and the constituent structure (Haugereid & Morey, 2012). The parse tree is left-branching, and is built incrementally (Figure (2)). Each step of the parse is licensed by a *structure*,

a subtype of *sign*. *Structures* have an ARGS list consisting of either one or two members. The first member describes the string parsed so far, and various features of this string are used to constrain the properties of the following word. These constraints are encoded in the second member of the ARGS list. An additional feature, VBL, is used to record whether a verb is still required, and if so, to pose constraints on that verb.

The grammar that generates the parse tree implements a stack that stores the necessary features of some ('matrix') constituent(s) while a dependent structure is generated. The grammar has tree types of rules; (i) *emb-struct* rules, (ii) *in-const-struct* rules, and (iii) *pop-struct* rules.

The *emb-struct* rules push constituent structures onto the stack, attaching the first word of the dependent. This is illustrated in ((27)), where the feature 'F [1]' represents the features of the matrix constituent, the feature 'F [2]' represents the features of the dependent, and the feature S represents the stack. The *in-const-struct* rules add words to constituents that have already been initiated. This type of rules is illustrated in ((28)), where the feature S, representing the stack, is transferred from initial daughter to mother. The rules used in our account of copulas in Hebrew are of this type, and as will be shown, this kind of rules can be unary-branching. Finally, *pop-struct* rules explicate dependent constituent structures, popping their matrix structure off the stack. This is illustrated in ((29)).

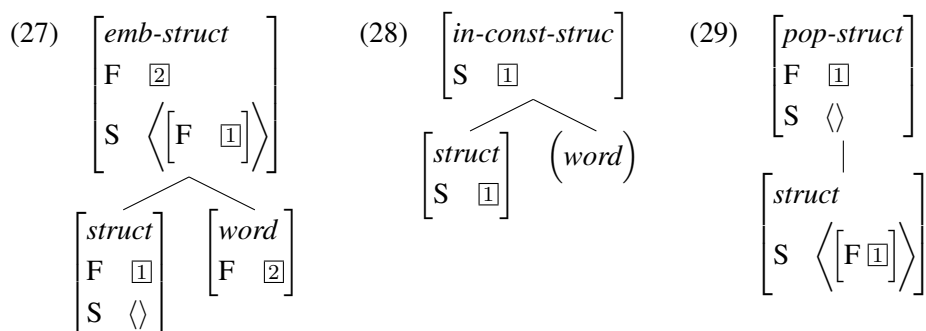

An analysis of a simple transitive sentence (*The boy is eating a fish*) is shown in Figure 2. A rule of type *vbl-struct*, which is a subtype of *in-const-struct*, adds the verb which is selected via the VBL feature (tagged [2]). The VBL value of the verb is transferred to the mother *vbl-struct*, thus constraining whether or not an additional verb is expected. In Hebrew, there will only be one verb, hence the VBL value transferred to the mother will always be *anti-synsem*.

Although the parse tree is strictly left-branching, a corresponding constituent structure which encodes the appropriate semantic structure can be extracted declaratively from the AVM resulting from the parse. For each node in the parse tree, the path to the root node of the corresponding constituent tree is reflected by the stack. When a dependent structure is introduced in the parse tree, with an *emb-struct* rule, a bracket is opened in the constituent tree, and when a dependent is com-

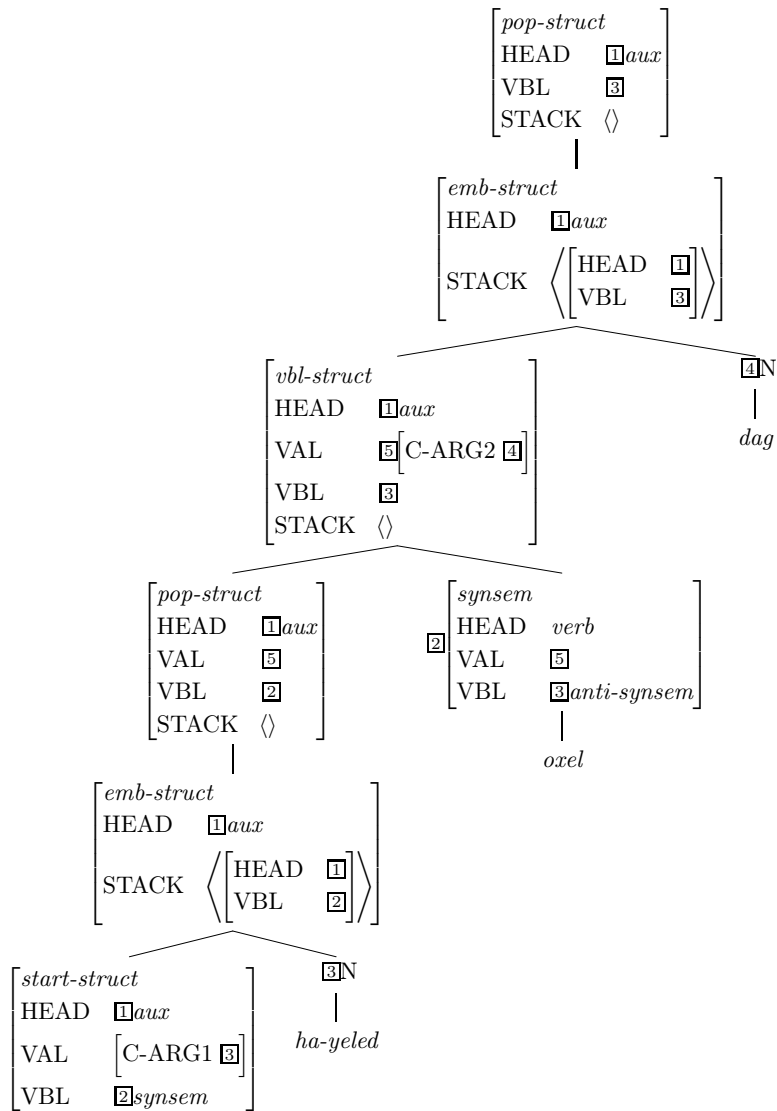

Figure 2: Parse tree for transitive sentence in Hebrew

pletely identified, with a *pop-struct* rule, a bracket is closed in the constituent tree. The constituent structure we assume is relatively flat; see Figure (3).

## 4.2 The Type Hierarchy

In accounting for nonverbal constructions in MH we distinguish between two cases: the present tense construction, with and without Pron, and the past/future construction with inflected *haya* ‘be’. Nevertheless, we recognize a set of properties that the two types have in common. This is reflected in the type hierarchy in Figure 4.

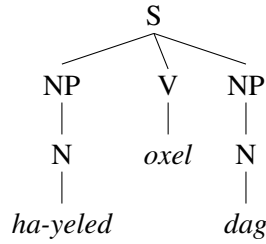

Figure 3: Constituent tree for transitive sentence in Hebrew

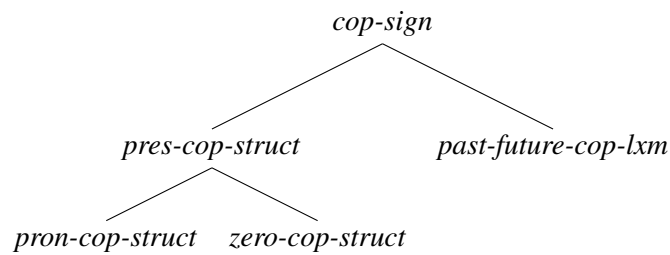

Figure 4: Type hierarchy of copula signs

The type *cop-sign* subsumes all copula signs and specifies their valence requirements and semantic content.

$$(30) \left[ \begin{array}{l} \text{cop-sign} \\ \text{VAL} \left[ \begin{array}{l} \text{C-FRAME } arg12-14 \\ \text{C-ARG1 } \left[ \begin{array}{l} \text{CAT | HEAD } noun \\ \text{CONT | INDEX } \boxed{3} \end{array} \right] \\ \text{C-ARG2 } \left[ \begin{array}{l} \text{CAT | HEAD } c-i-n \end{array} \right] \\ \text{C-ARG4 } \left[ \begin{array}{l} \text{CAT | HEAD } adj-adv-p \\ \text{LKEYS | KEYREL | ARG1 } \boxed{3} \end{array} \right] \end{array} \right] \\ \text{VBL } anti-synsem \\ \text{KEYREL } cop-rel \end{array} \right]$$

The syntactic relationship between the subject and the predicate is defined in the VAL feature. The value *arg12-14* of C-FRAME indicates a transitive frame. C-ARG1 is associated with the subject, and the different kinds of predicates are distributed over two alternating features: C-ARG2 is associated with direct object-like arguments (of type *c-i-n*: S, VPinf, and NP), and C-ARG4 is associated with delimiters (AdjP, AdvP and PP). With C-ARG4 predicates an additional constraint is stated: the INDEX value of the subject (tagged  $\boxed{3}$ ) is structure-shared with the ARG1 of the key relation denoted by the predicate. This constraint introduces a semantic predication relation between the two elements. Moreover, it ensures the full agreement between subjects and AdjP predicates, since adjectives are required



to agree with the noun they modify (i.e., the ARG1 of their key relation), whether predicationally or attributively.

Similarly to Van Eynde, and contrary to previously mentioned HPSG analyses, the semantic content of the copula is not vacuous. Rather, the semantic function of the copula in all three constructions is to link the INDEX of the subject with that of the predicate in *copula-rel*.<sup>4</sup> Unlike standard accounts, KEYREL is specified in the type hierarchy, rather than the lexicon, so that all the three types of copulas inherit this constraint.

The similarity between the two types of constructions ends when the categorial status of the copular element is considered, and thus two immediate subtypes are defined: *pres-cop-struct* and *past-future-cop-lxm*. Following Doron (1983) we posit that the past and future tense forms of *haya* are truly verbal, while the present tense copula, *Pron*, is the realization of agreement features.

The lexeme type of *haya* inherits the syntactic and semantic characterizations of *cop-sign*. The lexeme-specific information defined for it are its category, tense specification, and the structure-sharing of its RELS feature with KEYREL.<sup>5</sup>

$$(31) \left[ \begin{array}{l} \textit{past-future-cop-lxm} \\ \text{HEAD} \quad \textit{verb} \\ \text{CONT} \quad \left[ \begin{array}{l} \text{INDEX} \quad \left[ \text{TENSE} \quad \textit{past-fut} \right] \\ \text{RELS} \quad \langle ! \boxed{1} ! \rangle \end{array} \right] \\ \text{KEYREL} \quad \boxed{1} \end{array} \right]$$

The type *pres-cop-struct* is of subtype of *in-const-struct*, and, as such, licenses the combination of a parsed structure with the next word. The constraints on this type require that the HEAD and VAL features of the structure parsed so far be ‘passed up’ to the newly parsed structure. Moreover, it constrains tense to be ‘present’. Naturally, this information is inherited by the two subtypes, which account for the alternation between copular and copula-less constructions.

$$(32) \left[ \begin{array}{l} \textit{pres-cop-struct} \\ \text{HEAD} \quad \boxed{1} \textit{aux-subcompl} \\ \text{VAL} \quad \boxed{2} \\ \text{INDEX} \quad \left[ \text{TENSE} \quad \textit{present} \right] \\ \text{KEYREL} \quad \boxed{3} \\ \text{ARGS} \quad \left\langle \left[ \begin{array}{l} \text{HEAD} \quad \boxed{1} \\ \text{VAL} \quad \boxed{2} \\ \text{VBL} \quad \textit{synsem} \end{array} \right], \dots \right\rangle \\ \text{C-CONT | RELS} \quad \langle ! \boxed{3} ! \rangle \end{array} \right]$$

<sup>4</sup>This is illustrated in the MRS structures discussed in section 4.3.

<sup>5</sup>Angle brackets with exclamation marks ( $\langle ! \dots ! \rangle$ ) are used for representing difference lists in HPSG grammar implementations.

One subtype, *pron-cop-struct*, licenses the combination of a parsed structure (the first element in ARGS) with Pron (*pron-cop*, the second element in ARGS). In addition to all the constraints inherited from its supertypes, this particular type ensures number-gender agreement between the subject (C-ARG1 in the parsed structure) and Pron.

$$(33) \left[ \begin{array}{l} \textit{pron-cop-struct} \\ \text{ARGS} \left\langle \begin{array}{l} \left[ \text{VAL} \mid \text{C-ARG1} \left[ \text{INDEX} \left[ \begin{array}{l} \text{NUM} \quad \boxed{1} \\ \text{GEN} \quad \boxed{2} \end{array} \right] \right] \right], \\ \textit{pron-cop} \\ \left[ \text{INDEX} \left[ \begin{array}{l} \text{NUM} \quad \boxed{1} \\ \text{GEN} \quad \boxed{2} \end{array} \right] \right] \end{array} \right\rangle \end{array} \right]$$

The Pron element that appears in the ARGS list was shown here to be distinct from verbs, pronouns, and clitics. For this reason we define for it a separate category with a specific head feature: *pron-cop*. The definition of the singular-masculine Pron *hu* ‘he’ is given in (34).

$$(34) \left[ \begin{array}{l} \textit{sgm-pron-cop} \\ \text{STEM} \quad \langle hu \rangle \\ \text{CAT} \quad \left[ \text{HEAD} \textit{pron-cop} \right] \\ \text{CONT} \quad \left[ \begin{array}{l} \text{INDEX} \quad \left[ \begin{array}{l} \text{NUM} \textit{sg} \\ \text{GEN} \textit{masc} \end{array} \right] \\ \text{RELS} \quad \langle !! \rangle \end{array} \right] \end{array} \right]$$

The licensing of zero copula is achieved by the second subtype, *zero-cop-struct*, a unary rule which introduces the empty Pron. In practice this means that the rule imposes the constraints of *cop-sign* (and *pres-cop-struct*) on the parsed structure without attaching a phonologically realized Pron. It should be noted that although we do not define a phonologically empty Pron in the lexicon, in employing such a unary rule we are in fact proposing the existence of an underlyingly present empty Pron.

$$(35) \left[ \begin{array}{l} \textit{zero-cop-struct} \\ \text{ARGS} \quad \langle \textit{struct} \rangle \end{array} \right]$$

The type hierarchy proposed here captures the similarities and differences between the three different nonverbal predicate constructions found in MH: the present tense construction, with and without Pron, and the past/future construction with inflected *haya* ‘be’. The non-standard grammar design adopted here introduces into the type inventory of the grammar a new type *structure*, which licenses the incremental construction of a representation. The proposed grammar makes

use of binary parsing rules which incorporate ‘the next word’ into the structure, and unary parsing rules, which in effect incorporate empty elements and which impose constraints on the structure by way of type inheritance.<sup>6</sup> As will be shown in the next section, in adopting an incremental parsing design we do not lose information regarding the constituent structure and semantic relations between the different components of the sentence. This information is reflected in the constituent tree and MRS representation that are produced by the grammar.

### 4.3 Example Analyses

In order to illustrate the proposed analysis and its implementation we will first consider the following simple zero-copula construction:

- (36) ha-oto (hu) po  
the-car (he) here  
‘The car is here.’

The parse tree produced for this sentence is shown in Figure 5. The parse begins similarly to the standard transitive structure illustrated in Figure 2 above. However, once the parser consumes the first NP constituent the analysis diverges. In the simple transitive clause case, the *vbl-struct* type licenses the introduction of the verb. In the zero-copula construction there is no phonologically realized verb or copula. Instead the parser assumes a null copula, a step which is licensed by the *zero-cop-struct*, a unary rule, and then proceeds to consume the adverbial predicate *po* ‘here’.

In the constituent structure produced for this sentence (Figure 6) a phonologically null Pron is represented. As was discussed earlier, the application of the unary *zero-cop-struct* rule on the parsed structure imposes the syntactic and semantic properties associated with the copular construction. Consequently, the feature structure which is associated with the fully parsed sentence captures the semantic relations between the subject and predicate, regardless of the occurrence or absence of a copular element. The MRS of the sentence in (36) given in (37).

$$(37) \left[ \begin{array}{l} \text{mrs} \\ \text{LTOP} \quad \boxed{h1} \ h \\ \text{INDEX} \quad \boxed{e2} \ e \\ \\ \text{RELS} \quad \left\langle \begin{array}{l} \left[ \begin{array}{l} \text{.car}_n \_1 \_rel \\ \text{LBL} \quad \boxed{h3} \ h \\ \text{ARG0} \quad \boxed{x4} \ x \end{array} \right], \left[ \begin{array}{l} \text{def}_q \_rel \\ \text{LBL} \quad \boxed{h5} \ h \\ \text{ARG0} \quad \boxed{x4} \\ \text{RSTR} \quad \boxed{h6} \ h \\ \text{BODY} \quad \boxed{h7} \ h \end{array} \right], \left[ \begin{array}{l} \text{copula}_v \_rel \\ \text{LBL} \quad \boxed{h8} \ h \\ \text{ARG0} \quad \boxed{e2} \\ \text{ARG1} \quad \boxed{x4} \\ \text{ARG4} \quad \boxed{h9} \ h \end{array} \right], \left[ \begin{array}{l} \text{here}_a \_rel \\ \text{LBL} \quad \boxed{h9} \\ \text{ARG0} \quad \boxed{e10} \ e \\ \text{ARG1} \quad \boxed{x4} \end{array} \right] \right\rangle \\ \\ \text{HCONS} \quad \left\langle \begin{array}{l} \left[ \begin{array}{l} \text{qeq} \\ \text{HARG} \quad \boxed{h6} \\ \text{LARG} \quad \boxed{h3} \end{array} \right] \end{array} \right\rangle \end{array} \right]$$

<sup>6</sup>It should be noted that the use of this empty element is constrained to a very specific context.

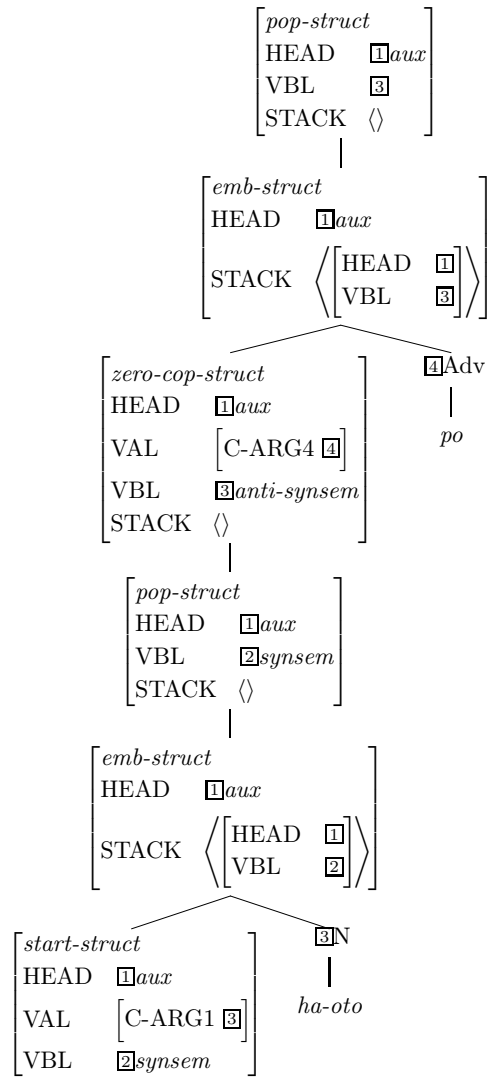

Figure 5: Parse tree for copula sentence with zero copula in Hebrew

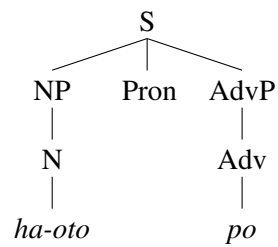

Figure 6: Constituent tree for copula sentence with zero copula in Hebrew

The *copula\_v\_rel* relation links ARG1 with ARG4, where the value of the former is the INDEX of the subject (tagged  $\overline{x4}$ ), and the latter is the label of the relation denoted by the predicate (tagged  $\overline{h9}$ ). Moreover, the value of ARG1 in the Adverbial *here\_a\_rel* relation is structure-shared with the INDEX of the subject. These links are defined in the supertype *cop-sign*.

A different case is VPinf predicates, which are realized as ARG2 complements. The following MRS is a representation of the semantics of the sentence given in (3) ('The goal is to enjoy.')

$$(38) \left[ \begin{array}{l} \text{mrs} \\ \text{LTOP} \quad \overline{h1} \ h \\ \text{INDEX} \quad \overline{e2} \ e \\ \\ \text{RELS} \quad \left\langle \begin{array}{l} \left[ \begin{array}{l} \text{goal}_n\text{-I\_rel} \\ \text{LBL} \quad \overline{h3} \ h \\ \text{ARG0} \quad \overline{x4} \ x \end{array} \right], \left[ \begin{array}{l} \text{def-q\_rel} \\ \text{LBL} \quad \overline{h5} \ h \\ \text{ARG0} \quad \overline{x4} \\ \text{RSTR} \quad \overline{h6} \ h \\ \text{BODY} \quad \overline{h7} \ h \end{array} \right], \left[ \begin{array}{l} \text{copula\_v\_rel} \\ \text{LBL} \quad \overline{h8} \ h \\ \text{ARG0} \quad \overline{e2} \\ \text{ARG1} \quad \overline{x4} \\ \text{ARG2} \quad \overline{e9} \ e \end{array} \right], \left[ \begin{array}{l} \text{enjoy\_v-I\_rel} \\ \text{LBL} \quad \overline{h10} \ h \\ \text{ARG0} \quad \overline{e9} \\ \text{ARG1} \quad \overline{u11} \ u \end{array} \right] \end{array} \right\rangle \\ \\ \text{HCONS} \quad \left\langle \begin{array}{l} \text{qeq} \\ \text{HARG} \quad \overline{h6} \\ \text{LARG} \quad \overline{h3} \end{array} \right\rangle \end{array} \right]$$

Here, in *copula\_v\_rel* ARG1 is the INDEX of the subject (tagged  $\overline{x4}$ ) and ARG2 is the event INDEX of the *enjoy\_v-I\_rel* relation, denoted by the VP (tagged  $\overline{e9}$ ).

A more complex case is the construction which led Bender (2001) to conclude that empty elements are necessary in order to account for copula absence in AAVE: complement extraction. The key example which Bender used to illustrate this challenge is *Where your car?*, where a predicative phrase is extracted, yet there is no phonologically realized element where this extraction can be registered. An additional complication to this construction is the case exemplified in (39), where a predicate is extracted from a zero-copula construction, leaving behind an adverb. The zero copula in this case not only records the extraction but is also accessible for modification.

(39) eifo ata xoshev she-ha-oto axshav?  
 where you.2SM think.SF that-the-car now  
 'Where do you think the car is now?'

Our grammar handles such cases and produces the correct analysis. The constituent tree constructed for this sentence is given in Figure 7. Note the empty Pron and the AdvP<sub>i</sub>, indicating the extraction site.

#### 4.4 Implementation and Evaluation

The analysis proposed here is implemented with the LKB system (Copestake, 2002) as part of HeGram, a computational grammar of Modern Hebrew. HeGram is

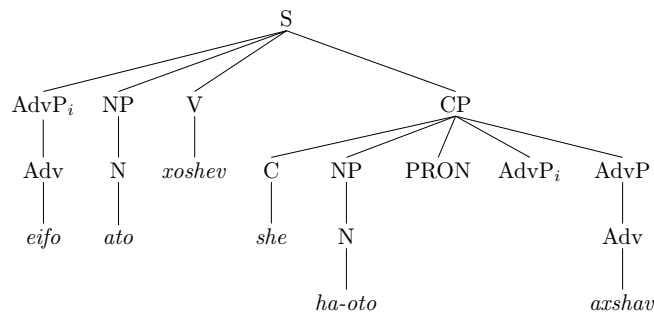

Figure 7: Complement extraction

based on the Norsyg grammar (<http://moin.delph-in.net/NorsygTop>), and is a part of the DELPH-IN effort (<http://www.delph-in.net/>). We integrated into the grammar a wide-coverage morphological processor of Hebrew (Itai & Wintner, 2008), thereby obtaining broad coverage and robustness. Consequently our lexicon now includes over 30 thousand lemmas, or some 150,000 inflected forms. The grammar covers basic clause structures such as main clauses, subordinate clauses, relative clauses and infinitival VPs. It handles long distance dependencies, modification, word order, agreement and object marking.

To test the grammar, we created a test suite of positive and negative items in the format of [incr tsdb()] (Open & Flickinger, 1998). The suite tests agreement between the subject and the AdjP predicate and between the subject and Pron, empty copula constructions, word order alternations, and subject and predicate extraction (including extraction from subordinate clauses).

Our grammar fully covers the positive items, assigning the correct expected syntactic and semantic structures to all of them. In terms of negative examples, the grammar slightly overgenerates. This is due to the fact that the binary copula construction is allowed to insert a Pron *after* the predicate and the subject. While this is grammatical for regular verbs, including *haya* and its inflected forms, it is strongly questionable for Pron. We have not yet decided whether or not this should be ruled out by the grammar.

Not covered by the grammar are: the interface between syntax, semantics, and pragmatics<sup>7</sup>; constraints on the choice between copula and zero copula; the interaction between copular constructions and the existentials; the complex agreement between NP subjects and NP predicates; and copular constructions with *ze* as copula<sup>8</sup>. These issues are left for future research. In addition, we plan to investigate similar constructions in Standard Arabic and explore the possibility of adapting the MH grammar to account for them.

<sup>7</sup>Müller (2009) distinguishes between three types of copular constructions (equational, predicational, and specificational) and argues that a uniform analysis of all three is inappropriate.

<sup>8</sup>The differences and similarities between the two types of pronominal copulas are discussed by Greenberg (2008).

## References

- Baroni, Marco, Silvia Bernardini, Adriano Ferraresi & Eros Zanchetta. 2009. The WaCky wide web: a collection of very large linguistically processed web-crawled corpora. *Language Resources And Evaluation* 43(3). 209–226.
- Bender, Emily M. 2001. *Syntactic variation and linguistic competence: The case of AAVE copula absence*: Stanford University dissertation. <http://faculty.washington.edu/ebender/dissertation/>.
- Copestake, Ann. 2002. *Implementing typed feature structure grammars*. Stanford: CSLI publications.
- Davies, Mark. 2004-. BYU-BNC. (Based on the British National Corpus from Oxford University Press) Available online at <http://corpus.byu.edu/bnc/>.
- Doron, Edit. 1983. *Verbless predicates in Hebrew*: University of Texas, Austin dissertation.
- Falk, Yehuda N. 2004. The Hebrew present-tense copula as a mixed category. In *Proceedings of the lexical functional grammar 04 conference (lfg-04)*, .
- Ginzburg, Jonathan & Ivan A. Sag. 2000. *Interrogative investigations: the form, meaning, and use of English interrogatives*. Stanford, California: CSLI Publications.
- Greenberg, Yael. 2008. Predication and equation in Hebrew (nonpseudocleft) copular sentences. In Sharon Armon-Lotem, Gabi Danon & Susan Rothstein (eds.), *Current issues in generative Hebrew linguistics*, 161–196. Amsterdam: John Benjamins Publishing.
- Haugereid, Petter & Mathieu Morey. 2012. A left-branching grammar design for incremental parsing. In Stefan Müller (ed.), *Proceedings of the 19th international conference on HPSG*, 181–194. <http://csli-publications.stanford.edu/HPSG/2012/haugereid-morey.pdf>.
- Henri, Fabiola & Anne Abeillé. 2007. The syntax of copular construction in Mauritian. In Stefan Müller (ed.), *The proceedings of the 14th international conference on HPSG*, 130–149. Stanford: CSLI Publications. <http://csli-publications.stanford.edu/HPSG/8/>.
- Itai, Alon & Shuly Wintner. 2008. Language resources for Hebrew. *Language Resources and Evaluation* 42(1). 75–98.
- Müller, Stefan. 2002. Multiple frontings in German. In Gerhard Jäger, Paola Monachesi, Gerald Penn & Shuly Winter (eds.), *Proceedings of Formal Grammar 2002*, Trento. <http://hpsg.fu-berlin.de/~stefan/Pub/mehr-vf.html>.

- Müller, Stefan. 2009. On predication. In *Proceedings of the 16th international conference on HPSG*, 213–233. Stanford: CSLI Publications. <http://hpsg.fu-berlin.de/~stefan/Pub/predication-hpsg.html>.
- Müller, Stefan. to appear. Elliptical constructions, multiple frontings, and surface-based syntax. In G. Penn G. Jäger, P. Monachesi & S. Wintner (eds.), *Proceedings of Formal Grammar 2004*, Nancy.
- Oepen, Stephan & Daniel P. Flickinger. 1998. Towards systematic grammar profiling. Test suite technology ten years after. *Journal of Computer Speech and Language* 12 # 4 Special Issue on Evaluation. 411 – 436.
- Pollard, Carl J. & Ivan A. Sag. 1987. *Information-based syntax and semantics, vol. 1* (CSLI Lecture Notes 13). Stanford University: CSLI Publications. Distributed by University of Chicago Press.
- Pollard, Carl J. & Ivan A. Sag. 1994. *Head-driven phrase structure grammar*. Chicago: University of Chicago Press.
- Van Eynde, Frank. 2008. Predicate complements. In Stefan Müller (ed.), *The proceedings of the 15th international conference on HPSG*, 253–273. Stanford: CSLI Publications. <http://csli-publications.stanford.edu/HPSG/9/>.
- Van Eynde, Frank. 2009. On the copula: from a Fregean to a Montagovian treatment. In *Proceedings of the 16th international conference on HPSG*, 359–375. Stanford: CSLI Publications. <http://csli-publications.stanford.edu/HPSG/2009/>.
- Van Eynde, Frank. 2012. On the agreement between predicative complements and their target. In Stefan Müller (ed.), *Proceedings of the 19th international conference on HPSG*, 348–366. <http://csli-publications.stanford.edu/HPSG/2012/vaneynde.pdf>.



# Reanalyzing German correlative *es*

Anke Holler 

University of Göttingen

Proceedings of the 20th International Conference on  
Head-Driven Phrase Structure Grammar

Freie Universität Berlin

Stefan Müller (Editor)

2013

Stanford, CA: CSLI Publications

pages 90–109

Holler, Anke. 2013. Reanalyzing German correlative *es*. In Stefan Müller (ed.), *Proceedings of the 20th International Conference on Head-Driven Phrase Structure Grammar, Freie Universität Berlin*, 90–109. Stanford, CA: CSLI Publications. DOI: 10.21248/hpsg.2013.5.



## Abstract

The present article discusses several aspects of the so-called correlate-*es* construction in German. This complex clausal construction can be identified by a correlative nominal element *es* ('it') occurring in the matrix clause and a right-peripheral full clausal argument linked to *es*. The article supports the hypothesis that correlative *es* has a janus-faced nature between an expletive and a referential meaning. This is the reason why existing approaches are not sufficient to capture the properties of the discussed construction in its entirety. The first part of the article sums up the common view on correlative *es* including the empirical properties of the construction as well as a brief survey of the relevant previous approaches trying to account for correlative *es*. Based on new empirical data, the second part of the article shows that none of these accounts is able to capture all relevant facts of the correlate-*es* construction because existing approaches usually ignore that the realization of correlative *es* is verb-class dependent. Hence, a new constraint-based analysis is developed that takes both empirical observations into account, the verb-class dependence and the janus-faced nature.

## 1 Introduction

Several Germanic languages use correlatives to mark subordination. German is considered to be a prime example of a language realizing correlative constructions to embed finite argument clauses. The present article discusses complex clausal constructions in German that can be identified by a so-called correlative nominal element *es* ('it') and a right-peripheral full clausal argument that is linked to *es*. On an intuitive level *es* functions as an antecedent of the linked argument clause in these constructions. Although correlative *es* is a well-established phenomenon of German grammar, there is no theoretical account that captures the empirical facts comprehensively. In particular, the homonymy of *es* between an expletive and a referential realization form often remains unnoticed. In this article, the janus-faced nature of correlative *es* is empirically substantiated. On the basis of the reported empirical observations the article develops a new constraint-based analysis.

The article is organized as follows: After describing the phenomenon in section 2 and summing up the results of previous studies dealing with correlative *es* in section 3, empirical data that has not yet been captured in existing proposals are given in section 4. Taking into account the new data basis, section 5 then develops and outlines the aforementioned new constraint-based analysis. To conclude, the results of the paper are presented in section 6.

---

<sup>†</sup>I thank Katrin Axel for valuable discussions on the topic and the audience of the HSPG 2013 conference in Berlin for helpful comments. I am also indebted to Christine Göb for thoroughly proof-reading the manuscript and useful assistance in conducting the corpus studies. All remaining errors are of course mine.

## 2 The Phenomenon

The correlate-*es* construction is characterized by a correlative element, *es* ('it'), which occurs in the matrix clause in subject or object position and is case-marked by the matrix predicate. This correlative *es* relates in some way to a finite *dass* ('that')-marked clause serialized to its right in the syntactic surface structure.<sup>1</sup> A typical example of the correlate-*es* construction is given in (1). Most of the standard approaches assume that the *dass*-clause is located in an extraposed position since it follows the matrix clause's finite verb if the finite verb is linearized sentence-finally. Semantically, the *dass*-clause contributes to the representation the proposition that matches the selectional restrictions of the matrix predicate.

- (1) Hotzenplotz bedauert es, dass er außer Räuberei nichts gelernt hat.  
*Hotzenplotz regrets it that he except for robbery nothing learned has*  
'Hotzenplotz regrets that he has learned nothing but robbery.'

In the described configuration *es* is usually analyzed as a means of recursive sentence embedding, which functions as a structural element filling a syntactic position and referring cataphorically to the right-peripheral argument clause.

As has been already observed in traditional grammar of German the occurrence of *es* is subject to certain topological restrictions. Since German is a verb-second language, it offers a so-called prefield position.<sup>2</sup> If the *dass*-clause is topicalized to this position, *es* is obligatorily omitted, cf. (2). Also, the *dass*-clause may not be serialized adjacent to *es* in the so-called middle field, cf. (3).

- (2) Dass er außer Räuberei nichts gelernt hat, bedauert (\*es)  
*That he except for robbery nothing learned has regrets it*  
Hotzenplotz.  
*Hotzenplotz*  
'That he has learned nothing but robbery, Hotzenplotz regrets.'

- (3) weil Hotzenplotz (\*es), dass er außer Räuberei nichts gelernt  
*because Hotzenplotz it that he except for robbery nothing learned*  
hat, bedauert.  
*has regrets*  
'because Hotzenplotz regrets that he has learned nothing but robbery.'

The topological data in (2) and (3) are mostly taken as further evidence for the hypothesis that the finite clause has to be extraposed obligatorily if correlative *es* is realized. In any case, an analysis aiming at a solid treatment of the correlate-*es* construction has to cover these topological facts.

The data presented in this section mainly form the basis for existing approaches to the correlate-*es* construction.

---

<sup>1</sup>In fact, there are further infinite construction types involving *es* that are not considered in this paper, cf. Müller (1999). The presented analysis, however, can easily be transferred to these types.

<sup>2</sup>In main clauses, the prefield position results from fronting the finite verb.

### 3 The traditional view on the correlative-*es* construction

#### 3.1 Previous generative approaches

In principle, there are two competing approaches to correlative *es* in research literature. They differ fundamentally in two respects: firstly, in the analysis of the syntactic and semantic status of correlative *es*, and, secondly, in the interpretation of the grammatical relation between *es* and the linked right-peripheral finite clause.

One strand of research (e.g. Bennis 1987, Cardinaletti 1990, Sonnenberg 1992, Engel 2004) analyzes *es* as a case- and theta-marked argument of the matrix predicate. Correlative *es* projects a nominal phrase and adds a referential index to the representation. The corresponding finite *dass*-clause functions as an explicative (appositive) attribute of *es*. This view is usually implemented by adjoining the *dass*-clause to a verbal projection (V' or VP) containing *es* as a verbal argument. One consequence of this analysis is that both correlative *es* and the finite *dass*-clause constitute two independent constituents to the representation.

The other strand of research holds that correlative *es* and the finite *dass*-clause form together just one (discontinuous) nominal constituent (e.g. Zimmermann 1993, Zifonun 1995, Müller 1996, Sudhoff 2003, Sternefeld 2006) that is subcategorized and theta-marked by the matrix predicate. In this constellation *es* behaves like an expletive, which is linked to the extraposed *dass*-clause. The specific approaches of this analysis variant differ with respect to the way the *dass*-clause is integrated into the nominal phrase containing *es*. Müller (1996) and Sudhoff (2003) propose that *es* acts as the functional head of this nominal phrase and obligatorily selects the *dass*-clause as its complement. Zimmermann (1993) argues that the *dass*-clause modifies the maximal nominal projection.

For both presented analytical options constraint-based analyses have been developed as is discussed in more detail in the next section.

#### 3.2 Previous constraint-based approaches

The few existing previous constraint-based approaches follow the tradition of Pollard & Sag (1994), who treat English correlative constructions only. Pollard & Sag (1994) analyze English *it* as an expletive form which cannot take over any semantic role. Thus, the matrix predicate does not assign the respective role to the correlative *es* but to the finite clause, which has to be extraposed obligatorily. Pollard & Sag (1994) implement this analysis by defining the Extraposition Lexical Rule which operates on the SUBCAT list of the respective verbs. The output structure of this rule for the verb *to bother* in examples like (4) is exemplified in figure 1. In fact, the lexical rule replaces the finite clause that is selected by *to bother* by the nominal expletive *it*, and appends the finite clause to the end of the verb's SUBCAT list.

- (4) It bothers Kim that Sandy snores.

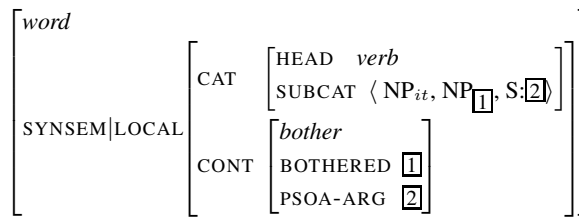

Figure 1: Output structure of Extraposition LR according to Pollard & Sag (1994)

Although the role of correlative elements in recursive sentence embedding has received considerable attention in German grammar writing and the last decades' generative theory, only a few constraint-based approaches on German have dealt with this issue so far. The two most prominent ones are those by Berman et al. (1998) and Kathol (1995).

### 3.2.1 The approach of Berman et al. (1998) couched in LFG

Berman et al. (1998) develop an unification-based analysis in the framework of lexical-functional grammar (LFG henceforth) that is based on a comparison between correlate-*es* constructions like (5) and data sets like (6). (The examples are taken from Berman et al. 1998.)

- (5) Hans hat es bedauert, dass er gelogen hat.  
*Hans has it regretted that he lied has*  
 'Hans regretted that he lied.'

- (6) a. Hans hat bedauert, dass er gelogen hat.  
*Hans has regretted that he lied has*  
 'Hans regretted that he lied.'
- b. Hans hat es bedauert.  
*Hans has it regretted*  
 'Hans regretted it.'
- c. Hans hat den Vorgang bedauert.  
*Hans has the event regretted*  
 'Hans regretted the event.'

According to Berman et al. (1998) the data in (6) indicate that the propositional argument of the matrix predicate *bedauern* ('to regret') can have several realization forms. The respective argument in the object role can be either realized by a clausal complement, i.e. a CP as in (6a) or "by the pronominal *es* which in this usage anaphorically refers to a proposition known from context" [Berman et al., 1998: 1] as in (6b). In addition, (6c) shows that in certain cases even a full nominal phrase denoting propositional entities may realize this argument. Based on these

observations Berman et al. (1998) conclude that a correlate-*es* construction like (5) results from merging constructions of the form (6a) and (6b).

Against the background of the aforementioned facts, the analysis proposed by Berman et al. (1998) relies on three basic assumptions: (i) *es* behaves like a referential pronoun, (ii) *es* and the *dass*-clause share the same argument slot of the matrix predicate in syntax but not in semantics, and (iii) the proposition introduced by the finite clause restricts the independently introduced variable of the referential pronoun *es*. The fundamental technical idea of the Berman et al. (1998) proposal concerns assumption (ii): That *es* and the *dass*-clause in fact share the same argument slot is achieved by unifying their f-structure contributions under the same function. Consequently, both *es* and the *dass*-clause differ at the categorial level—*es* is analyzed as a nominal phrase, the *dass*-clause as a clausal phrase—but share the same grammatical function OBJ(ect) at the level of grammatical functions.

The unification-based analysis proposed by Berman et al. (1998) is charming since it is not necessary to categorize the *dass*-clause syntactically as an appositive or adjoined clause although it is possible to interpret *es* referentially. Moreover, the co-occurrence of correlative *es* with a finite clause is licensed without further assumptions by general constraints on c-structures and f-structures in a LFG-fragment of German. On the other hand, the proposition introduced by the *dass*-clause semantically restricts the independently introduced variable of the referential pronoun *es* by adding more information. Hence, the finite clause behaves semantically like a typical apposition. Thus, Berman et al.'s approach follows the assumptions of standard generative approaches analyzing *es* as a referential pronoun. The main criticism of such an approach, however, is that it overlooks empirical data showing that *es* is not generally referential but may also behave like an expletive when it occurs in the context of certain verbs. The set of data substantiating this criticism is given below in section 4.

### 3.2.2 The approach of Kathol (1995) couched in HPSG

Kathol's (1995) HPSG proposal for the analysis of correlative *es* shares with the presented LFG analysis by Berman et al. (1998) the assumption that *es* has properties of a referential pronoun. Consequently, Kathol (1995) criticizes Pollard & Sag's (1994) treatment of similar constructions in English in that they analyze *it* as an expletive form that cannot carry any semantic role. Moreover, Kathol (1995) points out that in Pollard & Sag's (1994) approach the intuition is not reflected that there is a linkage between the correlative forms (*it* in English and *es* in German) on the one side and the extraposed clause on the other side. Kathol claims that any analysis should convey the observation that the correlative *es* somehow signals the presence of the propositional argument later in the clause.

Unlike Berman et al. (1998), Kathol (1995) does not act on the syntactic level of grammatical functions but on the semantic level of argument structure by reversing the relationship between syntactic complements and their semantic representations in the correlate-*es* construction: The thematic role previously thought to

be borne directly by the propositional argument is now assigned to the correlative *es* directly. The direct consequence of such an assumption is that *es* is interpreted referentially because an expletive cannot take over any thematic role by definition. Another consequence is that the propositional argument cannot carry the thematic role any more. In other words, the finite *dass*-clause cannot function as direct semantic argument of the respective matrix predicate because the referentially used *es* saturates the respective argument position. Kathol suggests that the clausal argument is instead linked to the role assigned to the index of *es*, and that this linkage is established via a relational CONTEXT feature called ANCHOR. The *anchor* relation takes two arguments: the restricted nominal index of *es* and the index of the correlated clause being of sort *parameterized states-of-affairs*. With the lexical entry given in figure 2 Kathol (1995) illustrates this analysis for the verb *stören* (‘to bother’) in an example like (7).

- (7) *dass es Kim stört, dass Sandy schnarcht.*  
*that it Kim bothers that Sandy snores*  
 ‘that it bothers Kim that Sandy snores.’

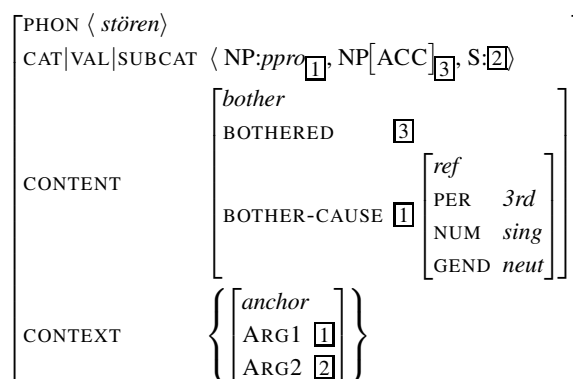

Figure 2: Lexical entry with correlative according to Kathol (1995)

In fact Kathol (1995) uses the *anchor* relation for two purposes. Firstly, it is supposed to cope with the aforementioned intuition that the correlative forms are in some sense linked to the constituent they are correlated with. Secondly, the *anchor* mechanism is needed for technical reasons to avoid a sort mismatch which would be the consequence if the indices of the correlative (which is a restricted nominal index of sort *ppro*) and the clausal argument (which is of sort *psoa*) were structure-shared directly.

Last but not least it should be mentioned that the topological generalizations on order in correlate-*es* constructions, which have been presented in section 2, are captured in Kathol’s linearization-based approach by an additional constraint accessing the *anchor* relation. Roughly speaking, it says that a constituent whose

content value is linked via an *anchor* relation to the index of some other entity is required to occur in an extraposed position.

### 3.3 Summing up

If one evaluates the various proposals discussed above, it turns out that in a sense all of them are right, but each of them may account only for a partial data set. Neither of the existing approaches is able to account for German correlative *es* in its entirety. The main reason for this is that all previous approaches overlook the fact that correlative *es* may behave like both an expletive and as a referential pronoun depending on the respective syntactic context. In particular, existing constraint-based approaches suffer from the lopsided view on *es* as a referential pronoun.

In the following section I will present corpus-based support for the hypothesis that the German correlative *es* distinguishes between two realization forms: an anaphoric referential pronoun and a true expletive. Pütz (1975) has already stated that these two types of correlative *es* may exist. His claim, however, is based on introspection and does not rest on empirical data.

## 4 Empirical evidence for the Janus-faced nature of *es*

In this section, I will argue on the basis of empirical data that correlative *es* is homonymous between an expletive and a referential form. A first step in proving this hypothesis is the evaluation of so-called correlate-taking verbs.

It is a well-established assumption of standard German grammar that verbs may be classified with respect to their ability to select correlative *es*. Surprisingly, there is no consensus in research literature when it comes to this classification. For instance, so-called *verba dicendi* and *sentiendi* like *sagen* ('to say'), *meinen* ('to think'), *hören* ('to hear'), *behaupten* ('to assert'), etc. are sometimes ranked as correlate-taking and sometimes as correlate-rejecting. The list of inconsistently classified verbs could be extended. One reason for the uncertainty in the evaluation of the respective verbs may be that the empirical basis of the classification is often very thin. The classifications often rely on construed examples or on unsystematically collected corpora. In the latter case a single item taken from a corpus is often regarded as sufficient evidence for a certain hypothesis. Boszák (2009) is a recent example of this fallacy.

Based on a quantitative corpus study<sup>3</sup> published in Axel, Holler & Trompelt (in press) it can be empirically substantiated that in fact there is a categorial distinction between two verb classes: With the first class of verbs (class I henceforth), correlative *es* is robustly attested. This is shown in figure 3 where the blue bars

---

<sup>3</sup>Methodically, a group of 35 verbs for which divergent judgments exist in the literature was selected. For each verb, the number of hits was limited to 1000 by random selection. Of those 1000, the first 100 examples in which the *dass*-clause really functions as the object clause of the critical verb were manually selected.



indicate the number of examples with *es*. With the second class of verbs (class II henceforth), however, correlative *es* is not attested among the hundred examples investigated as can be seen in figure 4.

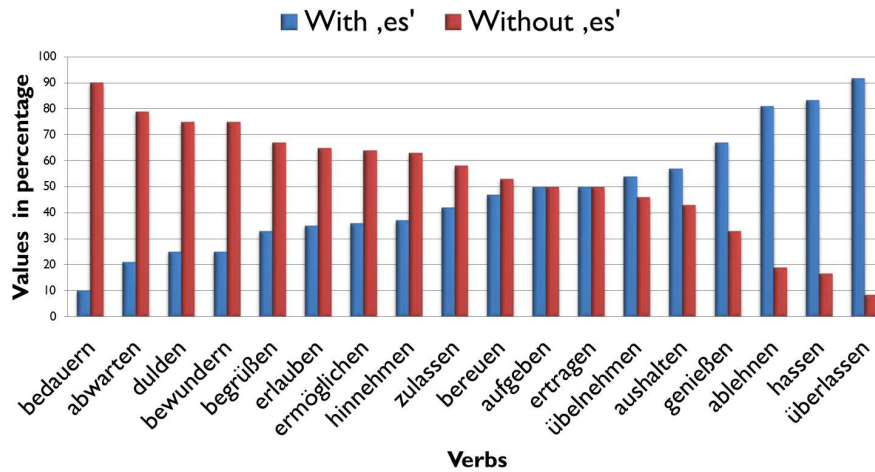

Figure 3: Corpus results for verbs of class I (Axel, Holler & Trompelt, in press)

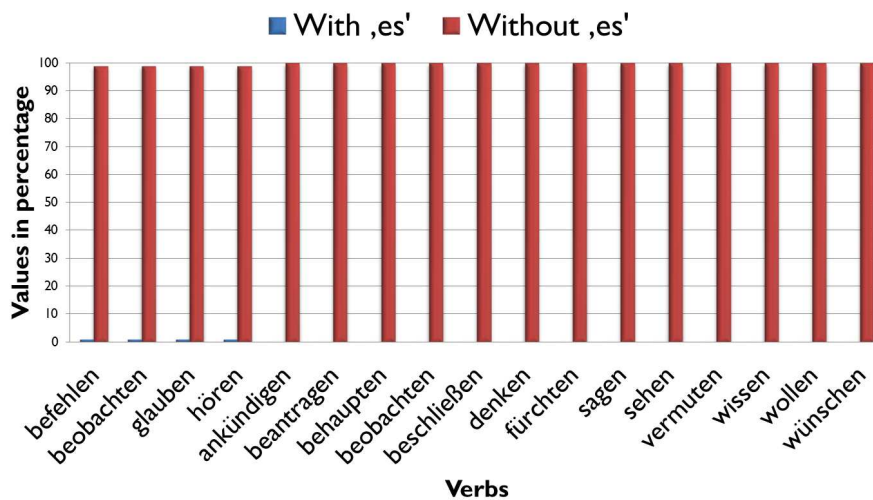

Figure 4: Corpus results for verbs of class II (Axel, Holler & Trompelt, in press)

At first glance, the result for the second verbal class is incomprehensible since it comprises verbs like *glauben* ('to believe'), *sagen* ('to say') and *wissen* ('to know') that are usually regarded as correlate-taking in German grammar theory. In fact, sporadic examples like (8), where one of these verbs is used with correlative *es*, can also be found in corpora, although the quantitatively obtained results for the second verbal class seem to be clear-cut.

- (8) Es ist schrecklich, wenn vor so vielen Dingen ein dunkler Vorhang  
*it is awful if in front of so many things a dark curtain*  
 ist. Ich möchte ihn immer nur zerreißen, aber ich kann es nicht. Ich  
*is I want to it always only tear but I can it not I*  
 glaube es dir, dass Du den Vorhang nicht zerreißen kannst.  
*believe it you that you the curtain not tear can*  
 ‘It is awful that so many things are behind a dark curtain. I believe that you  
 cannot tear the curtain.’

[TLP, 29, cited from Grammatik der Deutschen Sprache: 1487]

The puzzling empirical situation suggests to examine the direct context of the *es*-containing complex clauses with a predicate of class II in more detail. As a result of such analyses, one recognizes that in all of these cases *es* seems to refer back to a contextually given, discourse-old entity and hence behaves like an anaphoric element. In (8) the content of the *dass*-clause is discourse-old since both the curtain, and the act of tearing of the curtain are mentioned in the previous sentences. In other words, *es* seems to refer back to a contextually given, discourse-old entity. It is licensed by a potential antecedent in the left context. This suggests that correlative *es* is used as an anaphoric pro-form in these cases and not as an expletive placeholder.

Thus, the underlying reason for the divergent classification of verbs with respect to their correlate-taking ability in the literature is probably due to the Janus-faced nature of correlative *es*. Obviously, *es* occurs in two realization forms: Combined with verbs of class I it just fills a syntactic position and functions as a placeholder, which is a structural element without any semantic contribution; combined with verbs of class II, however, it must be analyzed as an anaphoric pro-form referring back to a pre-mentioned state-of-affairs.

The presented corpus evidence supports introspective data by Pütz (1975), Sudhoff (2003) and Frey (2011), who conjecture on theoretical grounds that at least two classes of putative correlative-*es*-taking verbs need to be distinguished. They claim for instance that (i) class II verbs, but not class I verbs allow *wh*-extraction and embed V2-clauses in German; (ii) class II verbs do not occur with a full NP, but class I verbs do; (iii) class II verbs, but not class I verbs occur with *dass*-clauses containing modal particles; and last but not least, (iv) class II verbs do not occur with *es* in all-focus clauses, but class I verbs do. Moreover, Axel, Holler, & Trompelt (in press) have shown in a psycholinguistic study that *es* may function as both, a non-referential structural element and a referential anaphoric pro-form. The study demonstrates that the respective usage depends on the syntactic contexts and the verbal class involved.

In view of the empirical facts, we can conclude that any analysis of the correlate-*es* construction must be able to differentiate between a placeholder and a pro-form usage of *es*, and it must mark verbs with respect to their ability to occur

with a placeholder *es* or not. Since all existing theoretical approaches of correlative *es* lack this generalization, there is still a need for a comprehensive analysis accounting for the presented empirical facts. In the next section I will outline a constraint-based analysis that complies with the homonymy of *es*.

## 5 A new constraint-based analysis for correlative *es*

As the empirical facts presented in the previous section have demonstrated, any approach claiming to cope with the correlate-*es* construction has to be able to differentiate between a placeholder and a pro-form usage of *es*, and it has to be able to mark verbs with respect to their ability to occur with a placeholder or not. In order to account for these facts, I propose an analysis of correlative *es* that is based on the following assumptions:

First, *es* is lexically homonymous between an expletive placeholder and a referential pronoun (sort *ppro*), which means that the sort hierarchy for objects of sort *nom-obj* must be extended respectively. In particular, the sort *expletive* has to be further partitioned into at least three subsorts called *placeholder-es*, *prefield-es*, and *quasi-argument-es* as depicted in figure 5. This is necessary since correlative *placeholder-es* has to be distinguished from the so-called *Vorfeld-es* (*prefield-es*), which is a specific expletive form in German to mark the first position in a verb-second clause, cf. Lenerz (1985)<sup>4</sup>, and the quasi-argument *es*, which is an expletive form acting for instance as logical subject for so-called weather-verbs.

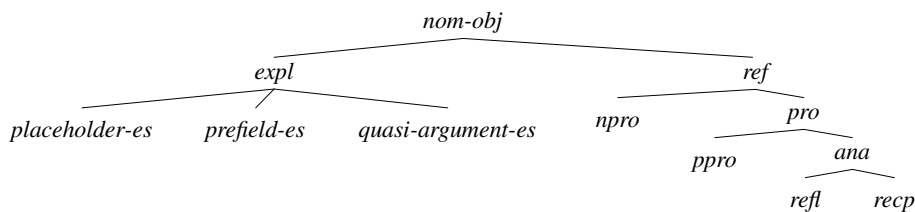

Figure 5: Partition of sort *nom-obj*

Additionally, it is assumed that expletive placeholder *es* and anaphoric pro-form *es* differ grammatically, which is also encoded in the lexicon. Figures 6 and 7 give the respective lexical entries for both realization forms of correlative *es*: *Es* as an expletive placeholder selects a clausal argument representing the finite clause. Note that this also means that the *dass*-clause is not selected by the matrix predicate. Consequently, *es* projects together with its complement, i.e. the finite clause, a nominal phrase that is case- and theta-marked by the respective matrix predicate (which must belong to the class I verbs and thus accepts placeholder *es*).

<sup>4</sup>Vorfeld-*es* is omitted if another constituent occupies the prefield, for instance as a consequence of topicalization.

In contrast to this, *es* as an anaphoric pro-form is fully saturated and has therefore an empty SUBCAT list. Contrary to expletive *es*, the finite clause is not syntactically licensed by anaphoric *es*.

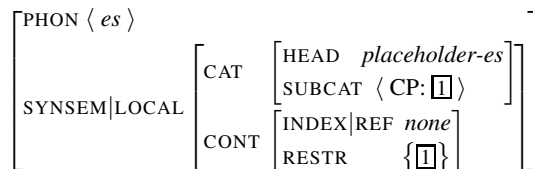

Figure 6: Lexical entry for expletive placeholder *es* (preliminary)

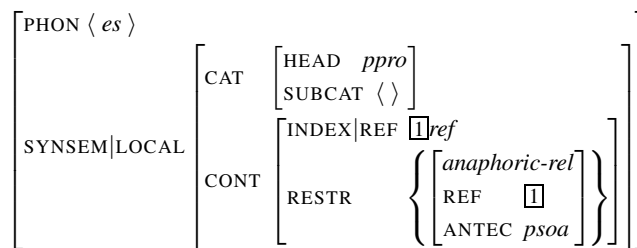

Figure 7: Lexical entry for anaphoric pro-form *es* (preliminary)

Semantically, the anaphoric pro-form *es* contributes, as any pronominal element, a referential index to the representation as well as an anaphoric relation that relates referential *es* to a suitable antecedent of sort *parameterized-state-of-affairs*.<sup>5</sup>

The placeholder *es*, however, does not make any semantic contribution on its own. It does not introduce a referential index. By itself the RESTRICTION value of the expletive placeholder *es* would equal the empty set; in fact it contains the *parameterized-state-of-affairs* which is introduced by the selected *dass*-clause. As exemplified in figure 6 this is achieved by structure-sharing the CONTENT value of the finite clause with the RESTRICTION value of placeholder *es*.<sup>6</sup>

In both cases, the proposed analysis reflects the intuition that the finite clause is linked to *es* but the nature of this linkage is different, and depends on the grammatical status of correlative *es* in each case. If *es* is an expletive, the finite clause is really selected by *es* and thus dependent on it in a closer sense. If *es* is an anaphoric pro-form, the impression of the linkage results from the resolution processes involved to satisfy the binary anaphoric relation *anaphoric-rel* introduced by pro-form *es*. It is established between *es* and its antecedent whose interpretation corresponds to the content of the finite *dass*-clause. This is the only reason

<sup>5</sup>Note that the proposed anaphoric relation resembles Kathol's *anchor* relation but it has the advantage to be motivated independently because it is introduced into the representation by any anaphoric element, not just the anaphoric pro-form *es*.

<sup>6</sup>See Müller (1999) for a similar approach.

why the *dass*-clause seems to be related to referential *es*.

The second fundamental assumption of the analysis concerns the HEAD value *verb*, which is sub-sorted in such a way that verbs can be divided lexically into placeholder-*es* taking verbs (= class I) and verbs that do not license a placeholder *es* (= class II), cf. figure 8.

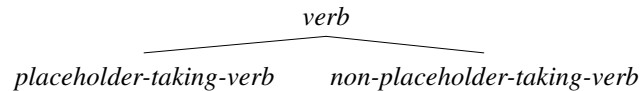

Figure 8: Partition of sort *verb*

Adopting a proposal by Sudhoff (2003), objects of these two verbal sorts differ lexically in their SUBCAT lists. While objects of sort *placeholder-taking-verb* (*ph-verb*) select a nominal argument and hence do not embed the clausal argument directly, objects of sort *non-placeholder-taking-verb* (*non-ph-verb*) are subcategorized for a clausal argument. This idea is illustrated by the partial lexical entries of the verbs *bedauern* ('to regret') and *behaupten* ('to assert') in figure 9.

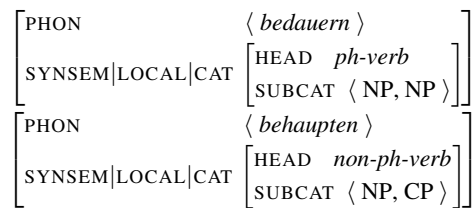

Figure 9: Verbal SUBCAT frames depending on the acceptance of a placeholder *es*

There are independent empirical reasons for the proposed differentiation of the SUBCAT lists of these two verbal classes. For instance: The outlined analysis accounts for the fact that only verbs of class I, but not of class II can occur with nominal phrases containing a full noun as the contrast between (9) and (10) demonstrates. Since verbs of sort *non-placeholder-taking-verb* select a clausal argument instead of a nominal one, as verbs of sort *placeholder-taking-verb* do, this empirical fact is captured without further assumptions. Note that the finite clause in (9a) is not dependent on the verb but it is selected by the relational noun *Tatsache*.

- (9) a. Hotzenplotz bedauert die Tatsache, dass er außer Räuberei  
*Hotzenplotz regrets the fact that he except for robbery*  
 nichts gelernt hat.  
*nothing learned has*  
 'Hotzenplotz regrets the fact that he has learned nothing but robbery.'

- b. Hans bedauert diese Tatsache.  
*Hans regrets this fact*  
 ‘Hans regrets this fact.’
- (10) a. \* Hotzenplotz behauptet die Tatsache, dass er außer Räuberei  
*Hotzenplotz asserts the fact that he except for robbery*  
 nichts gelernt hat.  
*nothing learned has*
- b. \* Hans behauptet diese Tatsache.  
*Hans asserts this fact*

Looking at the empirical facts in (11) two more remarks are necessary. First, examples like (11a) show that verbs of class I can also occur without a realized correlative *es*. To account for this fact, an additional lexical rule is needed just saying that an unstressed expletive placeholder may remain phonologically unrealized.<sup>7</sup> In other words, it is assumed that in this case the expletive *es* still selects the clausal argument but belongs to the class of *gap-ss* instead of *canon-ss* in the sense of Sag (1997) and Ginzburg & Sag (2000). Second, examples like (11b) show that an anaphoric *es* can in principle occur with verbs of class II. In addition to that, evidence that anaphoric *es* must be allowed in these cases also comes from data like (8) above. Given the selectional restrictions of verbs of sort *non-placeholder-taking-verb*, this seems to be surprising at first glance but in fact it follows from a general pronominalization rule that is needed anyway to pronominalize clausal entities.

- (11) a. Hotzenplotz bedauert, dass er außer Räuberei nichts gelernt hat.  
*Hotzenplotz regrets that he except for robbery nothing learned has*  
 ‘Hotzenplotz regrets that he has learned nothing but robbery.’
- b. Hotzenplotz behauptet {es, das}.  
*Hotzenplotz asserts it this*  
 ‘Hotzenplotz asserts {it, this}.’

The third major building block of the proposed analysis affects the finite *dass*-clause. The way of how it is related to *es* differs depending on the realization form of correlative *es*. If *es* functions as a placeholder, the *dass*-clause is a complement of *es*; if *es* functions as an anaphoric pro-form, the correlated *dass*-clause represents a non-integrated clause that behaves like an appositive (explicative) attribute. In both cases the final position of the finite clause at the right clausal edge is ensured.

Combined with a placeholder *es*, the finite clause is obligatorily extraposed, which is realized in a standard way by structure-sharing the CP-complement sub-categorized by *es* with an element of the *extra* list, cf. Keller (1994). See figure 10

<sup>7</sup>In light of examples like (2) it is necessary to implement into this constraint the requirement that the *dass*-clause is only optionally part of the EXTRA list if *es* is phonologically unrealized, in order to capture the fact that the finite clause may be topicalized in this case.

for the extended lexical entry of the placeholder *es*. From general constraints on extraposition then follows that the CP has to be positioned on the right periphery, which particularly means that it neither can be topicalized nor realized in the so-called middle field. Thus, the topological facts presented in section 2 are captured without further assumptions.

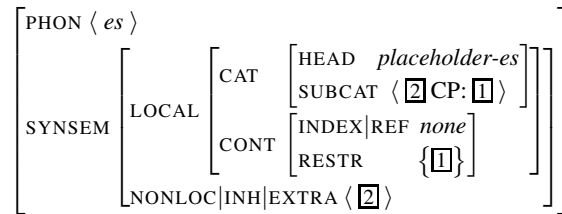

Figure 10: Lexical entry for expletive placeholder *es*

Combined with an anaphoric *es*, however, the CP behaves like an appositive clause and is thus analyzed as being of sort *fully-non-integrated*, cf. Holler (2008). Different approaches to capture non-integrated clauses have been developed. They differ basically in the way of how the non-integrated clause is connected to its host. The proposals range from radical orphanage analyses to analyses that adjoin the non-integrated clause to the highest position of the preceding clause. Which approach is adequate, is not relevant here because from any approach dealing with non-integrated clauses follows that clauses of this sort have to occur right-dislocated if not used parenthetically.

Having the status of the *dass*-clause at hand the lexical entry of pro-form *es* can be extended with respect to the specification of the antecedent that is suitable to resolve anaphoric *es* semantically. Since pro-form *es* behaves like an ordinary anaphoric element, it needs to be resolved. As has been said before the anaphoric relation introduced by *es* combines the referential index of anaphoric pro-form *es* with an entity of sort *parameterized state-of-affairs* which is introduced by the finite *dass*-clause. As the empirical facts discussed in section 4 have shown this relation can only be established if the semantic content of the finite clause is contextually given. To account for this it is required that the CONTENT value of the finite clause is contained in pro-form *es*'s BACKGROUND set. As depicted in figure 11 this is realized by structure-sharing the CONTENT value of the non-integrated *dass*-clause with an element of the BACKGROUND set. Additionally, the CONTENT value of the finite clause is accessible via the CONTEXT value of the anaphoric pro-form *es*, which contains a list of all linked, that means dependent but not embedded clauses. For more details on this differentiation see Holler (2008). The SYNSEM value of the appositive finite *dass*-clause, which is of sort *fully-non-integrated*, instantiates the LINKED list of anaphoric *es*. This is the reason why its CONTENT value is accessible and can constitute a proper antecedent of anaphoric *es*.

To illustrate the outlined approach to expletive and referential correlative *es* I will present an example analysis for both kinds of correlate-*es* constructions.

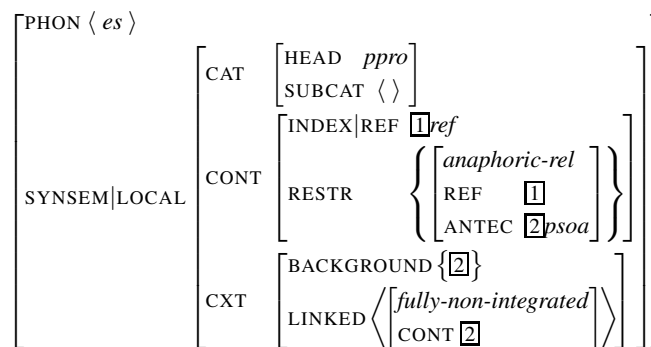

Figure 11: Lexical entry for anaphoric pro-form *es*

Beginning with the expletive placeholder *es*, figure 12 gives the partial structure for an example such as (12), which is a short version of (1). It illustrates the interplay of the lexical specification of placeholder *es* on the one hand and the requirements of the placeholder-taking verb *bedauern* ('to regret') on the other hand.

- (12) Hotzenplotz bedauert es, dass er nichts gelernt hat.  
*Hotzenplotz regrets it that he nothing learned has*  
 'Hotzenplotz regrets that he has learned nothing.'

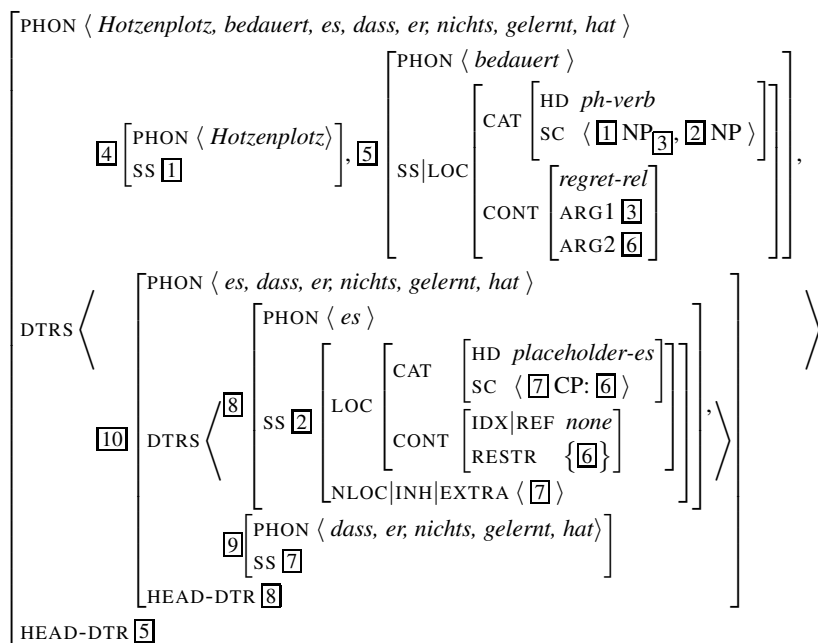

Figure 12: Example for a placeholder-*es* construction

In the attribute-value matrix depicted in figure 12, the placeholder-taking verb



*bedauern* ('to regret') functions as the HEAD daughter selecting both, the nominal subject *Hotzenplotz* (cf. tag [1]) and the expletive placeholder *es* (cf. tag [2]), which itself takes the finite clause as a complement (cf. tag [7]). According to the proposed analysis the finite clause is not dependent on the verb *bedauern*. It is instead subcategorized by the placeholder *es* (cf. tag [7]). This is the reason why the DAUGHTERS list of the whole correlate-*es* construction contains apart from the signs representing the verb *bedauern* (cf. tag [5]) and the nominal subject *Hotzenplotz* (cf. tag [4]) the complex object *es, dass er nichts gelernt hat* (cf. tag [10]). This sign is itself structured and consists of two daughters: *es* acts as the head daughter (cf. tag [8]) and the finite *dass*-clause (cf. tag [9]) acts as the complement daughter of *es*. Since its SYNSEM value is structure-shared with an element of the EXTRA list (cf. tag [7]), it is guaranteed that the *dass*-clause is realized in an extraposed position. Thus, it can neither occur in the pre-field nor in the middle field. The semantic interpretation of a correlative construction containing an expletive *es* is basically controlled by the interplay of the semantic relation introduced by the respective verb (i.e. *regret-rel*) and the lexical specification of placeholder *es*: Tag [6] marks the structure-sharing of the CONTENT value of the finite *dass*-clause with the RESTRICTION value of expletive *es*, which saturates the respective semantic role of *bedauern*. Note that expletive *es* does not contribute a referential index to the representation.

In the case of a non-placeholder-taking verb like *behaupten* ('to assert') occurring with the anaphoric proform *es* the partial analysis in figure 13 shows that the DAUGHTERS list of a correlate-*es* construction for an example such as (13)<sup>8</sup> contains four signs: Apart from the sign representing the verb *behaupten* and functioning as the HEAD-daughter of the clausal structure (cf. tag [5]), the signs representing the subject *Hotzenplotz* (cf. tag [6]), the anaphoric proform *es* (cf. tag [7]), and the non-integrated finite clause stand on the DAUGHTERS list (cf. tag [9]).

- (13) [...] Hotzenplotz behauptet es, dass er nichts gelernt hat.  
*Hotzenplotz asserts it that he nothing learned has*  
 '[...] Hotzenplotz asserts that he has learned nothing.'

In contrast to the analysis of the correlate-*es* construction with an expletive placeholder *es*, the *dass*-clause is not selected by *es*. Instead it is analyzed as being syntactically non-integrated, which means that it is of sort *fully-non-integrated*. Clauses of this sort are part of the LINKED list representing the syntactic context. Semantically, the CONTENT value of the *dass*-clause (cf. tag [8]) resolves the anaphoric referent introduced by *es* (cf. tag [4]). This is indicated by the relation *anaphoric-rel* added to the representation by *es*. Most important is the assumption that the finite *dass*-clause must be given that means it must be pre-mentioned in the left context. This fact is represented by the BACKGROUND set containing the CONTENT value of the finite clause (cf. tag [8]).

<sup>8</sup>Note that example (13) cannot be uttered out-of-the-blue. It is only adequate if the content of the *dass*-clause is pre-mentioned in the right context. [...] marks this aspect.

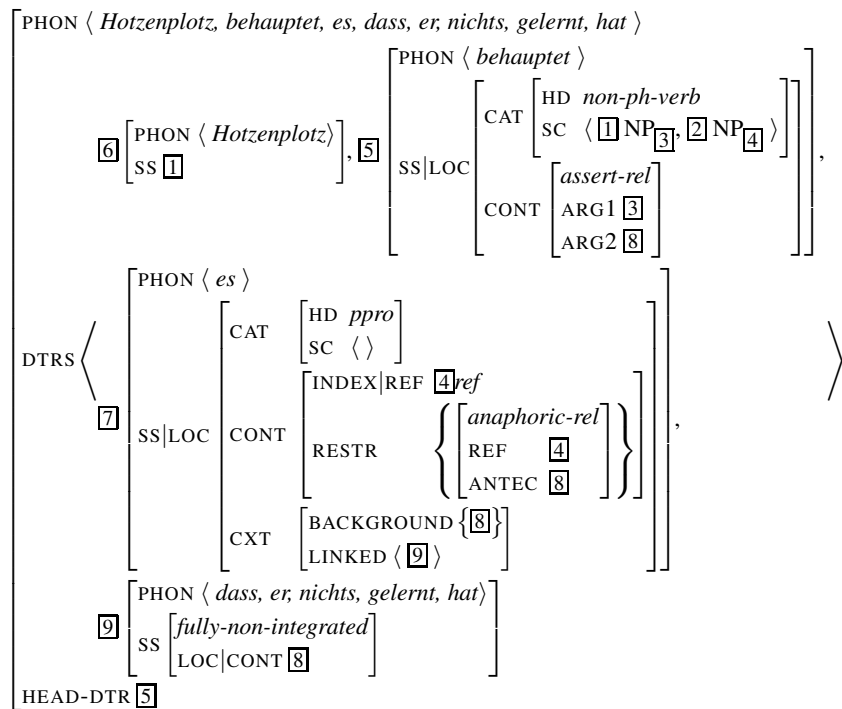

Figure 13: Example for an anaphoric proform-*es* construction

## 6 Conclusion

In the present article it has been argued that correlative *es* functions either as an expletive placeholder, which is a structural element without any semantic value, or as an anaphoric pro-form, which must be resolved by a suitable state-of-affairs. It has been shown empirically that the placeholder versus anaphoric use of correlative *es* is both verb-class dependent and context dependent. To account for these empirical facts the constraint-based analysis outlined in this article differentiates lexically between *es* as an expletive and *es* as a referential pronoun. As an expletive *es* is analyzed as a functional element without an own semantic contribution, but selecting a finite clausal argument. As a referential pronoun, there are three points to consider: Firstly, *es* is syntactically fully saturated; secondly, it contributes semantically a referential index to the representation; and thirdly, it needs to be resolved. Correspondingly, the dependent *dass*-clause is either selected by the expletive *es* or act as a syntactically non-integrated clause, which resolves semantically the anaphoric relation introduced by pro-form *es*. In the first case the *dass*-clause has to be extraposed obligatorily, in the latter case it follows from its non-integratedness that the *dass*-clause is positioned on the right periphery. It is to be expected that the analysis presented here can be transferred to other languages possessing correlative elements such as Dutch and Italian. This should be

examined carefully in further research.

## References

- Axel, Katrin, Anke Holler & Helena Trompelt. In print. Correlative *Es* vs. *Das* in German: An Empirical Perspective. In Kerstin Schwabe, André Meinunger & Werner Frey (eds.), *Inner-sentential propositional pro-forms*, Amsterdam/Philadelphia: John Benjamins.
- Bennis, Hans. 1987. *Gaps and Dummies*. Dordrecht/Providence: Foris Publications.
- Berman, Judith, Stefanie Dipper, Christian Fortmann & Jonas Kuhn. 1998. Argument clauses and correlative *es* in German — deriving discourse properties in a unification analysis. In Miriam Butt & Tracy Holloway King (eds.), *Proceedings of LFG98 conference*, Stanford: CSLI Publications.
- Boszák, Gizella. 2009. *Realisierung der valenzbestimmten Korrelate des Deutschen*. Frankfurt/M. u.a.: Peter Lang.
- Cardinaletti, Anna. 1990. *Impersonal Constructions and Sentential Arguments in German*. Padova: Unipress.
- Engel, Ulrich. 2004. *Deutsche Grammatik*. München: Iudicium.
- Frey, Werner. 2011. On the nominal character of clauses associated with a pronominal. Ms.
- Ginzburg, Jonathan & Ivan A. Sag. 2000. *Interrogative Investigations: the form, meaning, and use of English interrogatives*. Stanford: CSLI.
- Holler, Anke. 2008. German dependent clauses from a constraint-based perspective. In Cathrine Fabricius-Hansen & Wiebke Ramm (eds.), *Subordination vs. coordination in sentence and text.*, 187–216. Amsterdam/Philadelphia: John Benjamins.
- Kathol, Andreas. 1995. *Linearization-Based German Syntax*: Ohio State University dissertation.
- Keller, Frank. 1994. Extraposition in HPSG. Ms.
- Lenerz, Jürgen. 1985. Zur Theorie des syntaktischen Wandels: das expletive *es* in der Geschichte des Deutschen. In Werner Abraham (ed.), *Erklärende Syntax des Deutschen*, 99–136. Tübingen: Narr.
- Müller, Gereon. 1996. On Extraction and Successive Cyclicity. In Ulrich Lutz & Jürgen Pafel (eds.), *On Extraction and Extraposition in German*, 213–244. Amsterdam/Philadelphia: John Benjamins.

- Müller, Stefan. 1999. *Deutsche Syntax deklarativ. Head-Driven Phrase Structure Grammar für das Deutsche*. Tübingen: Max Niemeyer.
- Pollard, Carl & Ivan Sag. 1994. *Head-driven Phrase Structure Grammar*. Stanford/Chicago: CSLI Publications and University of Chicago Press.
- Pütz, Herbert. 1975. *Über die Syntax der Pronominalform es im modernen Deutsch*. Tübingen: Narr.
- Sag, Ivan A. 1997. English Relative Clause Constructions. *Journal of Linguistics* 33(2). 431–484.
- Sonnenberg, Bernhard. 1992. *Korrelate im Deutschen: Beschreibung, Geschichte und Grammatiktheorie*. Tübingen: Max Niemeyer.
- Sternefeld, Wolfgang. 2006. *Syntax. Eine morphologisch motivierte generative Beschreibung des Deutschen*. Tübingen: Stauffenburg.
- Sudhoff, Stefan. 2003. *Argumentsätze und es-Korrelate — zur syntaktischen Struktur von Nebensatzeinbettungen im Deutschen*. Berlin: Wissenschaftlicher Verlag.
- Zifonun, Gisela. 1995. Minimalia grammaticalia: das nicht-phorische es als Prüfstein grammatischer Theoriebildung. *Deutsche Sprache* 23. 39–60.
- Zifonun, Gisela, Ludger Hoffmann & Bruno Strecker. 1997. *Grammatik der deutschen Sprache*. Berlin/New York: de Gruyter.
- Zimmermann, Ilse. 1993. Zur Syntax und Semantik der Satzeinbettung. In Inger Rosengren (ed.), *Satz und Illokution 2*, 231–251. Tübingen: Max Niemeyer.

# Information structure constraints and complex NP islands in Chinese

Dawei Jin 

University at Buffalo, SUNY

Proceedings of the 20th International Conference on  
Head-Driven Phrase Structure Grammar

Freie Universität Berlin

Stefan Müller (Editor)

2013

Stanford, CA: CSLI Publications

pages 110–120

Jin, Dawei. 2013. Information structure constraints and complex NP islands in Chinese. In Stefan Müller (ed.), *Proceedings of the 20th International Conference on Head-Driven Phrase Structure Grammar, Freie Universität Berlin*, 110–120. Stanford, CA: CSLI Publications. DOI: 10.21248/hpsg.2013.6. 

## Abstract

This paper presents an analysis of the complex NP island effects in Chinese. I follow Ginzburg & Sag (2000)'s analysis of *in situ wh*-interrogative construction and propose that feature percolation from the non-head clause daughter to the head daughter is required for a proper treatment of *in situ wh*-relative. A semantic analysis of the idiosyncrasy of *weishenme* 'why' reveals that a definite reading is forced for a *wh*-relative when *weishenme* stays *in situ*. This requirement causes feature percolation into relative head to fail. In this way I show that the island effects in Chinese can be independently ruled out in the grammar as a case of contradiction.

## 1 Introduction

This paper proposes that the complex NP island constraints (henceforth: CNPC) in Chinese *wh*-interrogatives receive an information-structural explanation. I argue that mainstream treatments of CNPC in terms of movement constraints fail to predict the interpretational distinctiveness associated with different *wh*-phrases. On the other hand, island facts follow naturally from an independently motivated constraint on relative clause's propositional content, motivated by this distinctiveness. I adopt an HPSG implementation used in representing *in situ wh*-interrogatives (Ginzburg & Sag, 2000). I show this framework allows us to impose fine-grained interactional constraints that capture the relation between *wh*-phrases and semantic interpretation.

The rest of this paper will be structured as follows: Section 2 reviews the core data surrounding CNPC effects in Chinese; Section 3 summarizes previous theories on Chinese strong islands, couched in the transformational framework, and discusses their shortcomings; Section 4 examines the behavioral differences between reason adverbial *weishenme* 'why' and other *wh*-phrases in some detail, and derives the CNPC effects by an information-structural constraint based on this distinction; Section 5 presents an HPSG implementation of the above mentioned analysis; Section 6 concludes the paper.

## 2 Data

It has long been noted (Huang 1982; Aoun & Li, 1993; Tsai, 1994; Huang et al, 2009) that *in situ wh*-phrases in Chinese can circumvent the canonical CNPC effects, where proper interpretation cannot be established when a *wh*-phrase is associated with a relative-clause internal position. As (1) shows, when a *wh*-phrase is overtly fronted, both Chinese and English induce island effects; however, such effects disappear when Chinese *wh*-phrases stay *in situ*.<sup>1</sup>

- (1) a.?? What do you like the person [who wrote \_ ]?  
b.?? Shenme, ni xihuan [ xie \_ ] de ren?  
      *What, you like write REL person*  
c. Ni xihuan [shei xie \_ ] de shu?  
      *You like who write REL book*

- ‘Who<sub>i</sub> do you like the book(s) that <sub>i</sub> wrote?’  
 d. Ni xihuan [<sub>i</sub> xie shenme] de shu?  
*You like write what REL book*  
 ‘What topic<sub>i</sub> do you like book(s) that describes <sub>i</sub>?’

On the other hand, it has been claimed since Huang (1982) that CNPC obtains for *in situ* reason-adverbial, *weishenme* ‘why’, illustrated below.

- (2) #Ni xihuan [ta weishenme xie <sub>i</sub>] de shu?  
*You like he why write REL book*  
 #‘Why<sub>i</sub> do you like the books that he wrote <sub>i</sub>?’

Crucially, this contrast has been argued to be a matter of argument-adjunct distinction (Huang, 1982), given examples like the following, where island effects once again disappear when *weishenme* is replaced by an argumental reason *wh*-phrase, *yinweishenme* ‘because of what (reason)’.<sup>2</sup>

- (3) Ni xihuan [ta yinwei shenme xie <sub>i</sub>] de shu?  
*You like he because.of what write REL book*  
 ‘What reason do you like the book(s) that he wrote for that reason?’

### 3 Previous Analyses

The mainstream explanations of *weishenme*-induced CNPC (Huang et al, 2009; Cheng & Rooyrck, 2000; Cheng, 2009) have been to take the unruly behavior of *weishenme* as crucial evidence for the existence of covert movement. Specifically, these theories argue that for a *wh*-interrogative to receive proper interpretation in Chinese, the interrogative feature at the matrix scope position needs to be checked off at LF, the purported level of representation that provides the feed for semantic interpretation. One way to achieve feature checking is to move the *wh*-phrase to the matrix position at LF. However, the complex NP domain, which subsumes relative clause, constitutes a barrier against movement, inducing island effects. This explains why *weishenme* induces CNPC. To explain away the island-free behaviors of other *wh*-phrases, a separate, movement-free licensing mechanism for *wh*-interpretation, unselective binding (Pesetsky, 1987; Reinhart, 1998; Aoun & Li, 1993; Tsai, 1994), is proposed, which selectively targets *wh*-arguments.

However, this line of reasoning faces several difficulties.

Theoretically, a movement-based explanation should predict that the island effects disappear in overt pied piping, since it involves extraction of the entire complex NP domain, and therefore the *in-situ wh*-phrase should not cross any barrier. Overt pied-piping of the whole NP chunk to topicalized position is commonly attested in Chinese filler-gap constructions, as (4) illustrates.

- (4) a. [Shei xie <sub>i</sub>] de shu, ni xihuan?  
*Who write REL book, you like*  
 ‘Books written by who, do you like?’  
 b. [<sub>i</sub> xie shenme] de shu, ni xihuan?

*Write what REL book, you like*  
'Books which describe what, do you like?'

However, overt pied-piping fails to rescue *weishenme*-islands, as the following shows

- (5) #[Ta weishenme xie \_ ] de shu, ni xihuan?  
*He why write REL book, you like*  
'Books which he wrote why, do you like?'

Under a movement-based theory, this fact seems mysterious because there seems to be no non-stipulatory reasons why pied-piping should be ruled out as an option in (5).

Empirically, other adjuncts or adverbials are also island-free, as (6) shows.

- (6) a. Ni hui mai [ \_ mai duoshaoqian ] de shu?  
*You will buy sell how.much REL book*  
'How much will you buy the book(s) that were sold for that amount of money?'
- b. Ni xuyao [ na'er neng maidaao \_ ] de shu?  
*You need where can buy=RES REL book (REL: resultative)*  
'Where do you need the books that can be bought at that place?'

Therefore, the purported argument-adjunct asymmetry, motivated by the contrast between (2) and (3), is only apparent. The actual contrast w.r.t. CNPC effects involves *weishenme* versus all other *wh*-phrases. It seems hardly desirable that a structural mechanism is formulated upon one data point alone and is forced to rule out all the remainder.

Furthermore, structural theories fail to take account of the fact that the acceptability for *wh*-phrases in a relative is interpretation-dependent. Crucially, I argue that only generic readings are available for the aforementioned island-free examples. Because there is no definite determiners in Chinese, whether a relative head receives generic or definite readings is normally resolved by contexts. However, as (7) exemplifies, when a definite reading is forced via the presence of the demonstrative *nei* 'that', CNPC effects arise even for *in situ wh*-arguments.<sup>3</sup>

- (7) a. #Ni xihuan [shei xie \_ ] de nei-ben shu?  
*You like who write REL DEM-CL book*  
# 'Who<sub>i</sub> do you like that book that \_<sub>i</sub> write?'
- b. #Ni xihuan [ta yinwei shenme xie \_ ] de nei-ben shu?  
*You like he because.of what write REL DEM-CL book*  
# 'What<sub>i</sub> do you like that book that he wrote because of \_<sub>i</sub>?'

Conceivably, a structural theory may argue that definiteness markers can be barriers of movement. Indeed, Huang (1982) proposes exactly this kind of explanation for the following English example.



- (8) a. Who have you read reviews of \_?  
 b.\*Who have you read this review of \_?

However, the same explanation cannot be extended to the anti-definiteness effect in Chinese, because in such cases no movement occurs: *wh*-arguments undergo unselective binding, and binding, according to standard structural assumptions, is not sensitive to movement barriers (Cheng & Rooyrk, 2000; Cheng, 2009).

These suggest that we should look for the explanation for *weishenme*-induced CNPC within the interpretational component of grammar. Below I propose such an analysis.

#### 4 My Analysis

The semantics of *why* has long been noticed to be peculiar crosslinguistically (Bromberger, 1992; Szabolcsi & Zwarts, 1997). Recent literature has presented various treatments for *why*'s idiosyncrasy, e.g. *why* favors high attachment or late insertion (Ko, 2005). I will adopt Tsai (2008)'s proposal that Chinese *weishenme* takes the underlying event as its internal argument and functions as a sentential operator; On the other hand, the argumental reason *wh*-phrase *yinweishenme* 'because of what' modifies the underlying predicate and functions as a derived predicate in the manner of VP-adverbials. I argue this formulation can readily account for the differing interpretations elicited by the two *wh*-phrases.

For example, although the semantic distinction of *weishenme/yinwei shenme* does not yield logically distinct interpretations when a single event is under discussion, different interpretations arise when a multiple event reading is elicited through the introduction of a quantifier.

- (9) a. Lisi yinwei shenme cizhi?  
*Lisi because.of what resign*  
 'What reason does Lisi have for resigning?'  
 b. Lisi weishenme cizhi?  
*Lisi why resign*  
 'Why did Lisi resign?'  
 c. Weishenme duoshu ren cizhi?  
*Why most person resign*  
 'Why most people, not few people, resign? (What is the singular reason that causes most people in the salient discourse to resign?)'  
 d. Duoshu ren yinwei shenme cizhi?  
*Most person because.of what resign*  
 'What reason did most people have for resigning? (What reasons can account for the majority cases of resignations?)'  
 e. Weishenme meiyouren/henshaoren cizhi?  
*Why nobody/few person resign*  
 'Why nobody/few people resigned?'  
 f. Meiyouren/henshaoren yinwei shenme cizhi?  
*Nobody/few people because.of what resign*  
 'What reasons did nobody/few people have for resigning?'

Generalized quantifiers like *most/few* need to quantify over properties/predicates. Therefore they can only take *yinweishenme* as argument, whereas *weishenme* ranges above the entire quantified event as its argument. Thus when we adopt a strictly compositional semantic derivation by interacting reason *wh*-phrases with other constituents, the resulting logical interpretations will differ. This, I argue, underlies the purported island effects in Chinese.

To begin with, interpretation of a clause containing a *wh*-phrase requires the propagation of the interrogative feature (Fiengo et al, 1988; von Stechow, 1996). For example, when an interrogative NP is contained within another NP, as in *pictures of who*, the head NP will also be construed as interrogative. Just as *who* is a quantifier ranging over individuals, *pictures of who* may be construed as a quantifier ranging over pictures sets defined by their owners. This feature percolation idea has been implemented using different semantic frameworks, but the basic intuition remains the same.

In a *wh*-relative, *wh*-feature percolation requires the head noun to denote a set of entities defined in terms of the properties specified in the *wh*-phrase. For example, in (10)

- (10) Ni xihuan [shei xie \_ ] de shu?  
*You like who write REL book*  
 ‘Who is the person s.t. you like book(s) that (s)he wrote?’

The embedded *wh*-argument *shei* ‘*who*’ denotes a salient set of individuals who have written books, and the question ranges over any books that bear the property of being written by this set of individuals.

A definite reading, where the set of books are already salient from context, and we are inquiring after its author, is not available. That is to say, the identity of the books cannot be known *a priori*, but has to crucially rely on anchoring the identity of the individual who writes them.

Similarly, in (11), a set of alternative sets of books are characterized in terms of a set of discourse-salient reasons as follows

- (11) Ni xihuan [ta yinwei shenme xie \_ ] de shu?  
*You like he because.of what write REL book*  
 ‘What reason do you like the book(s) that he wrote for that reason?’

For example, imagine we have a context where a book A was written for reason  $R_1$ , a book B was written for reason  $R_2$ , etc. The *wh*-relative in (11) would pick out the set of books  $\{A, B, \dots\}$ , which are defined in terms of the set of reasons  $\{R_1, R_2, \dots\}$ . Crucially, the *wh*-feature must percolate from the clause-internal *wh*-phrase to the head, so that the identity of the head noun is determined by the property specified within the *wh*-phrase.

On the other hand, *weishenme* cannot lend itself to such an interpretation, because a *weishenme*-question necessarily solicits the cause of a particular event which is denoted by the propositional argument that *weishenme* takes. Therefore if in (11) *yinweishenme* is replaced by *weishenme*, the relative clause will derive a class of propositions as follows:

(12) {reason r1 CAUSES the event e, reason r2 CAUSES the event e, ... } where e stands for an event of book-writing, and  $R\{R_1, R_2, \dots\}$  are contextually salient reasons that might explain the occurrence of e.

Given that *weishenme* is anchored to a particular event, it cannot provide a classification base that derives multiple events. In fact, it is only logically coherent with a specific reading, i.e. there exists a reason that causes his writing a particular book that the addressee likes, and we are wondering what this reason is. Therefore, the discourse referent of the head noun is not anchored by the relative clause, it must be known *a priori*, and by locating this referent, we are retrieving the reason for this particular event.

This results in a paradox, because the propositional content within the relative clause plays no role in identifying the head noun, therefore feature propagation is impossible.

The anti-definiteness effect follows from the same reason: a demonstrative indicates that the discourse referent of the head noun is an *a priori* known entity salient from prior discourse. However, since the relative clause's propositional content is interrogative, it cannot serve to anchor this referent, therefore similar contradiction occurs.

## 5 Formalization

Below I present an HPSG formalization based on Ginzburg & Sag's (2000) analysis of *wh*-interrogatives. I show HPSG mechanisms neatly account for this island theory in terms of feature constraints, without incurring the difficulties encountered by a movement-based theory.

The Chinese *in situ wh*-relative construction can be treated as being subject to the constraints associated with matrix *in situ* interrogative clauses (*is-int-cl*) and embedded relative clauses (*rel-cl*). Importantly, *is-int-cl* possesses several peculiar properties compared to fronted *int-cl*. First, it must allow the non-initial *wh*-word in its *in situ* position to bear a specified WH-value (Ginzburg & Sag, 2000). Second, association of this WH-value at the root clause level needs to be guaranteed, in order for the matrix content type to be *question*. This requires the WH-value to percolate up via head, given there is no initial filler.

The following constraint by Ginzburg & Sag (2000) already allows WH-percolation to occur via the head-argument path:

(13) WH-Amalgamation Constraint

$$word \Rightarrow / \left[ \begin{array}{l} SS|WH \quad \boxed{\Sigma 1} \cup \dots \cup \boxed{\Sigma n} \\ ARG - ST \quad \langle [WH \boxed{\Sigma 1}], \dots, [WH \boxed{\Sigma n}] \rangle \end{array} \right]$$

As is discussed in my previous analysis, a crucial step to guarantee a question reading is to allow the WH-value to be shared with the relative head, so that it can percolate up all the way through the matrix clause head. This is formulated in a separate WH-amalgamation constraint:

(14) Rel WH-Amalgamation Constraint

$$rel-cl \Rightarrow / \left[ \begin{array}{l} SS|WH \quad \{[2]\} \\ MOD \quad \{[1]\} \\ SLASH \quad [1] [SS|WH\{[2]\}] \end{array} \right]$$

Finally, NPs with a definite reading will have a [DEF +] feature, whereas generic NPs receive a [DEF -] feature. This feature is specified in the CONTENT since it is a semantic/pragmatic feature. Thus a demonstrative head NP is marked [DEF +], so is the head NP of a *weishenme*-relative clause.

On the other hand, whenever a WH-value is specified for a word, the word must be indefinite. This is because a WH-word inherently ranges over a set of properties, and thus cannot ground a particular discourse referent. I incorporate this requirement by stipulating it as the following constraint:

(15) *A noun with a non-empty WH value must be [DEF -] in its CONTENT.*

$$noun \Rightarrow / \left[ \begin{array}{l} SS|WH \quad ne \\ CONT \quad [DEF -] \end{array} \right]$$

For an *wh*-argumental *is-int-cl* like (11), the WH value can percolate all the way up until getting associated at the root clause. First, through (13) it percolates to the embedded clause level, and then to the relative head via (14). Then (13) applies again, until it reaches the matrix root clause. Importantly, the relative head NP is marked [DEF-] when it inherits the WH-value. Also, the semantics of the relative clause results in a generic reading for the head NP, which also requires a [DEF-] value. These two requirements give compatible results, and the whole derivation can be implemented as follows:

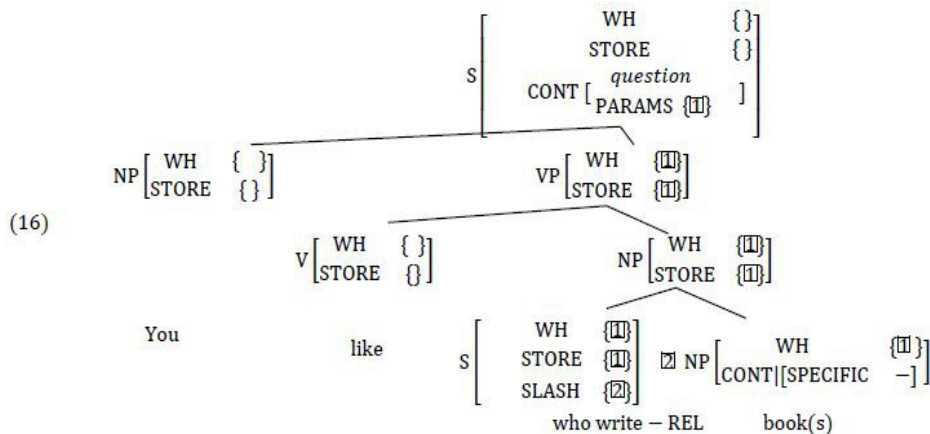

For a *weishenme is-int-cl* as in (2) (repeated below)

(17) #Ni xihuan [ta weishenme xie] de shu?  
*You like he why write REL book*  
 #‘Why<sub>i</sub> do you like the books that he wrote <sub>i</sub>?’

The WH-value of the relative clause percolates up to the head NP and requires it to be specified as [DEF-]. However, the semantics of the relative clause imposes

a definite reading for the head NP, marking it [DEF+]. These two competing feature valuations create contradiction, and as a result the type *weishenme is-int-cl* is ruled out by the interacting constraints and doesn't get generated. The representation of (17) is as follows:

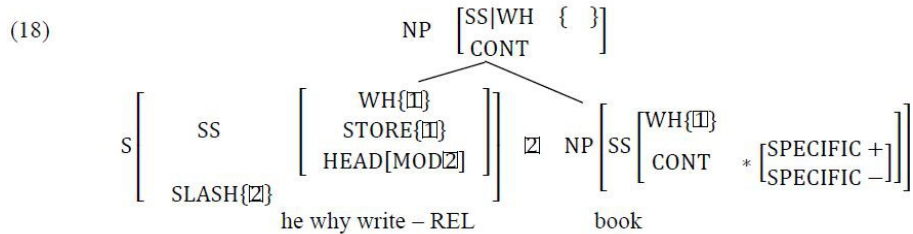

Similarly, when the type *wh-argumental is-int-cl* interacts with the type *definite-NP*, contradiction also arises. This explains the anti-definiteness effect. As the following shows, the presence of a demonstrative determiner marks the head NP as a [DEF+] NP, however, percolation of WH-value from the relative clause daughter requires the head NP to bear a [DEF-] value. The competing requirements cannot be accommodated, and therefore this structure is also ruled out.

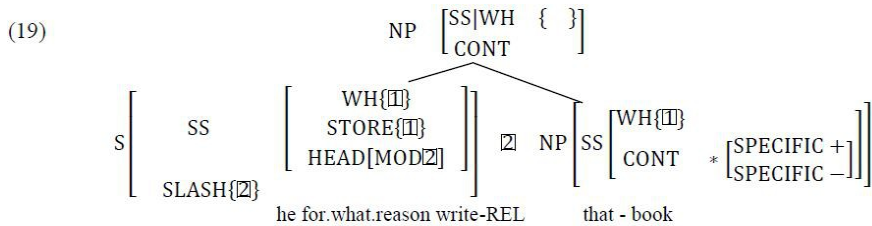

## 6 Conclusion

This paper argues that the CNPC in Chinese are explained by semantico-pragmatic mechanisms. Structural explanations fail to address the fact that the idiosyncratic semantics of *why* gives rise to different interpretations compared to other *wh*-phrases. I show that once this distinction is made, the interpretation differences underlie the judgment contrasts w.r.t. island effects. This solution is readily accommodated within a constraint-based HPSG framework.

This proposal suggests a simpler grammar, since there is no need to specify structural constraints on *in situ wh*-questions. Also, the removal of structural stipulations renders void the grounds for positing covert movement at the LF level. Thus *wh*-licensing mechanisms need not be sensitive to the syntactic categories of *wh*-phrases.

One consequence of this is on the evaluation of island theories. If we assume that *in situ* island effects are treated on a par with overtly displaced island effects, island theories that are formulated on overt displacement cannot be extended to *in situ* cases, thus suffering from an empirical disadvantage (Lasnik, 1999; Sprouse et al, 2012; Boeckx, 2012). For example, in processing-based theories, overt displacement is crucial because the dependency it creates imposes taxing

burden on the processing resources of a cognitive agent (Deane, 1991; Kluender, 1998; Hofmeister & Sag, 2010). As such this approach doesn't have an explanation for Chinese island effects. However, according to my theory, it is not necessary to make this extension. Therefore, although the current claim doesn't in principle favor nonstructural theories over structural ones, it enables a level playing ground by rendering the evidence from *in situ* islands irrelevant.

## Notes

1 Other strong island constraints can be similarly obviated, for example, adjunct islands and subject islands, illustrated as follows

- (i) a. Ta [yinweishenme jiegu yuangong] yihou bei laoban piping=le?  
*He because.of what sack employees after by boss criticize=ASP*  
 'For what reason<sub>i</sub> was he criticized by the boss after he sacked  
 b. [Ta yinweishenme cizhi] zui hao?  
*He because.of what resign be.most good*  
 'For what reason<sub>i</sub> will that he resigned   <sub>i</sub> be the best?'

These phenomena can follow from the analysis laid out in this paper. However, I will leave their exact formulation to future work.

2 The same asymmetrical pattern holds also for Japanese and Korean.

3 One can possibly accept this sentence in a reprise reading: where the *wh*-word serves as an anaphora that refers to a previously pronounced linguistic entity in prior discourse.

## References

- Aoun, J., & Li, Y. H. A. (1993). Wh-elements in Situ: Syntax or LF?.  
*Linguistic Inquiry*, 24(2), 199-238.
- Boeckx, C. (2012). *Syntactic islands*. Cambridge University Press.
- Bromberger, S. (1992). *On what we know we don't know: Explanation, theory, linguistics, and how questions shape them*. U Chicago Press.
- Cheng, L. L. S. (2009). *Wh-in-situ*, from the 1980s to Now *Language and Linguistics Compass*, 3(3), 767-791.
- Cheng, L., & Rooryck, J. (2000). Licensing Wh-in situ. *Syntax*, 3(1), 1-19.
- Choe, J. W. (1987). LF movement and pied-piping. *LI* 348-353.
- Deane, P. (1991). Limits to attention: A cognitive theory of island phenomena. *Cognitive linguistics*, 2(1), 1-63.
- Del Gobbo, Francesca. (2001). "Appositives schmappositives in Chinese."  
*UCI working papers in linguistics* 7 : 1-25.
- Erteschik-Shir, Nomi (2007). *Information Structure: The syntax-discourse interface*. Oxford.
- Fiengo, R., Huang, C. C. T. J., & Lasnik, H. (1988). The Syntax of Wh-in-

- Situ. In *Proceedings of the Seventh WCCFL*, 1988 (p. 81).
- Ginzburg, Jonathan & Sag, Ivan 2000. *Interrogative Investigations: The Form, Meaning and Use of English Interrogatives*. Stanford: CSLI.
- Hintikka, J., & Halonen, I. (1995). Semantics and Pragmatics for Why-questions. *The Journal of Philosophy*, 92(12), 636-657.
- Hofmeister, P., & Sag, I. A. (2010). Cognitive constraints and island effects. *Language*, 86(2), 366.
- Huang, James. 1982 *Logical Relations in Chinese and the Theory of Grammar*. MIT dissertation.
- Huang, J., & Li, A. (1996). *New horizons in Chinese linguistics*. Springer.
- Huang, J., Li, A. & Li, Y. (2009). *Syntax of Chinese* Cambridge: Cambridge .
- Kluender, R. (1998). On the distinction between strong and weak islands: A processing perspective. *Syntax and semantics*, 241-280.
- Ko, H. (2005). Syntax of why-in-situ: Merge into [Spec, CP] in the overt syntax. *Natural Language & Linguistic Theory*, 23(4), 867-916.
- Lasnik, H. (1999). On the locality of movement. *Functionalism and formalism in linguistics* 1, 33-54.
- Levine, R. D., & Hukari, T. E. (2006). *The unity of unbounded dependency constructions*. CSLI Publications.
- Li, Charles & Thompson, Sandra. 1989. *Mandarin Chinese: A functional reference grammar*. Univ of California Press.
- Pesetsky, D. (1987). Wh-in-situ: Movement and unselective binding. *The representation of (in)definiteness*, 98-129.
- Reinhart, T. (1998). Wh-in-situ in the framework of the Minimalist Program. *NALS*6(1), 29-56.
- Shlonsky, U., & Soare, G. (2011). Remarks and Replies: Where's 'Why'? *Linguistic inquiry*, 42(4), 651-669.
- Sprouse, J., Wagers, M., & Phillips, C. (2012). A test of the relation between working-memory capacity and syntactic island effects. *Language*, 88(1), 82-123.
- Stepanov, A., & Tsai, W. T. D. (2008). Cartography and licensing of wh-adjuncts: a crosslinguistic perspective. *NLLT*26(3), 589-638.
- Szabolcsi, A., & Zwarts, F. (1993). Weak islands and an algebraic semantics for scope taking. *NALS* 1(3), 235-284.
- Szabolcsi, A. (2006). Strong vs. weak islands. *The Blackwell companion to syntax*, 4, 479-531.
- Tomioka, S. (2009). Why questions, presuppositions, and intervention effects. *JEAL*18(4), 253-271.
- Tsai, W. T. D. (1994). On nominal islands and LF extraction in Chinese. *NLLT*12(1), 121-175
- Tsai, W. T. D. (2008). Left periphery and how-why alternations. *JEAL*17(2), 83-115.
- Watanabe, A. (1992). Subjacency and S-structure movement of wh-in-situ. *JEAL*1(3), 255-291.

# Usage preferences: The case of the English verbal anaphor *do so*

Philip Miller 

EA 3967 CLILLAC-ARP, Université Paris Diderot

Proceedings of the 20th International Conference on  
Head-Driven Phrase Structure Grammar

Freie Universität Berlin

Stefan Müller (Editor)

2013

Stanford, CA: CSLI Publications

pages 121–139

Miller, Philip. 2013. Usage preferences: The case of the English verbal anaphor *do so*. In Stefan Müller (ed.), *Proceedings of the 20th International Conference on Head-Driven Phrase Structure Grammar, Freie Universität Berlin*, 121–139. Stanford, CA: CSLI Publications. DOI: 10.21248/hpsg.2013.7. 



## Abstract

In this paper I introduce the notion of Usage Preferences (UPs), which are statistically significant preferences in usage which can concern any aspect of linguistics. I suggest that multiple violations of UPs can have additive effects, causing grammatical sentences to be judged as unacceptable. A new judgment on sentences is proposed, the downarrow ( $\downarrow$ ) to mark sentences that are taken to be grammatical but unacceptable due to UP violations. I illustrate the idea of UPs on the basis of a discussion of the English verbal anaphor *do so*, involving both a corpus analysis and two acceptability experiments. This leads to a discussion of the relationship between grammaticality and acceptability and to remarks on the methodological importance of taking UPs into account both in linguistic theorizing and in the construction of acceptability experiments.

## 1 Introduction: Usage Preferences

Most syntacticians will have been confronted, at some point, with the following paradoxical situation. One reads a paper that proposes a constraint C on a construction X and illustrates its relevance by exhibiting occurrences of X that violate C and that indeed appear to be quite unacceptable. Yet corpus research provides examples of X violating C which appear to be perfectly acceptable. This situation can be illustrated with the verbal anaphor *do so* as construction X and the exclusion of stative antecedents as constraint C. This constraint was first suggested by Lakoff & Ross 1976 and appears to have been generally accepted. Culicover & Jackendoff 2005 propose a stronger version, namely that *do so* does not allow non-action antecedents. They provide the following examples to illustrate their claim:<sup>1</sup>

- (1) a. \*Robin dislikes Ozzie, but Leslie doesn't do so. [Stative, C&J:284, their (2a), their judgment]
- b. ?\*Robin fell out the window, but Leslie didn't do so. [Non-action event, C&J:284, their (2b), their judgment]

However one can easily find attested examples of *do so* with stative antecedents. This was first pointed out by Michiels 1978 (a paper which apparently went com-

---

<sup>1</sup>Preliminary versions of the corpus data reported here were presented at the “Linguistic Evidence” conference in Berlin on April 5 2013 and at the “Structure and Evidence in Linguistics” workshop in Stanford on April 29 2013. I would like to thank participants in both these venues for their comments. I would like to thank Gabriel Flambard, Barbara Hemforth, Anne Jugnet, and Geoff Pullum for discussion and comments. I would also like to thank Corey Cusimano for setting up the experiments on the Ibex platform and running them on Amazon’s mechanical turk. Special thanks to Emilia Ellsiepen and to Barbara Hemforth for help with the statistical analysis. All remaining errors are my sole responsibility.

<sup>1</sup>In order to clarify the interpretation of examples I underline the antecedent and double underline the anaphor.

pletely unnoticed) who, embarrassingly, cited a series of examples from articles and books written by linguists, among which the following:

- (2) The basic idea is that whenever the relation of complementary distribution holds between phones belonging to a common phoneme, it does so because the phonetic value of the phoneme depends upon the phonetic environment in which it occurs. [Stative, in Fodor, Bever and Garret, *The Psychology of Language*, cited by Michiels 1978:175]

It appears to be completely impossible to explain such an example away as a speech error. It is in fact completely natural, and would most likely not be noticed at all when reading the paragraph of the book from which it is excerpted.

More recently, Houser 2010 has corroborated the acceptability of *do so* with stative antecedents through large-scale corpus investigation and an acceptability experiment. We are therefore confronted with a paradox: why do constructed examples of *do so* with a stative antecedent, such as (1) seem to be ungrammatical when examples of apparently the same type are attested in spontaneous usage of language and felt to be perfectly acceptable? The goal of this paper is to try to explain this apparently contradictory situation in terms of USAGE PREFERENCES (UPs).

Usage Preferences are statistically significant preferences in usage which can concern any aspect of linguistics, e.g. syntax, lexical semantics, compositional semantics, discourse pragmatics, register etc. In general, it appears that a single violation of a UP has little effect on acceptability. On the other hand I suggest that violations of UPs can have additive effects, causing strong unacceptability. I will illustrate the idea of Usage Preferences with respect to *do so* and suggest that the difference between (2) and (1a) is that the former violates one UP on *do so* whereas the latter violates three of them.

## 2 Usage Preferences for finite *do so*

English has two central types of verbal anaphors. On the one hand, there are a series of complex verbal anaphors based on main-verb *do*, among which *do it*, *do this*, *do that*, *do so*. On the other hand there is Post-Auxiliary Ellipsis (PAE, more commonly known as VP Ellipsis; an alternate analysis is possible where the auxiliary is taken to be a pro-predicate, see e.g. Schachter 1978, Hardt 1993). There have been a huge number of studies on PAE,<sup>2</sup> but far fewer on *do so* (see however Hankamer & Sag 1976, Michiels 1978, Culicover & Jackendoff 2005, Houser 2010). In this paper, I will focus on *do so*, providing both corpus data and data from psycholinguistic experiments.

<sup>2</sup>Among which Sag 1976 (who initially proposed Post-Auxiliary Ellipsis as a more appropriate label), Hardt 1993, Johnson 2001, Kehler 2002.

## 2.1 Corpus data on *do so*

Houser 2010 provides corpus data on *do so* based on the American National Corpus (<http://www.americannationalcorpus.org/OANC/index.html#>). Miller 2011 provides additional corpus data from the COCA corpus (Davies 2008-, <http://corpus.byu.edu/coca/>). On the basis of the results of these studies, the following UPs can be proposed for finite *do so*:

- (3) UP1 Finite *do so* very strongly prefers to occur with non-stative antecedents. (98% of cases according to Houser 2010)
- UP2 Finite *do so* very strongly prefers to occur referring to the same state of affairs as its antecedent and hence with the same subject as its antecedent. (98% of cases according to Miller 2011)
- UP3 Finite *do so* prefers to occur with a non-contrastive adjunct. (83% of cases according to Miller 2011)

We thus have three Usage Preferences which can be satisfied or not, giving us eight possible combinations, which are illustrated in (4), using attested examples when they are available.<sup>3</sup>

- (4) a. What is most important, in the end, is to make sure that the president makes the right decisions, that he does so in a timely manner, and that they are implemented effectively. (COCA) [UP1+, UP2+, UP3+]
- b. Nathan immediately bends down to pick them up but is jostled as he does so and stumbles, breaking his fall with his right hand ... (COCA) [UP1+, UP2+, UP3-]
- c. We assume that logical thought, syllogistic analytical reason, is the necessary, right thought—and we do so because this same thought leads us to think this way. (COCA) [UP1-, UP2+, UP3+]
- d. ... a story about someone who had paid the tolls for the car behind them as a random holiday gift. DH thought that this was just cool and fun so he did so at the tollbooths we encountered in our travels. (Houser 2010:135 [UP1+, UP2-, UP3+])
- e. He delighted in Mr. Spitzer's downfall—and continues to do so. (COCA, note that this is **nonfinite do so**) [UP1-, UP2+, UP3-]
- f. Soon after BMG began restructuring its businesses, some of its rivals did so too. (COCA) [UP1+, UP2-, UP3-]
- g. ↓Mary assumes that logical thought is necessary. Peter does so because this same thought leads us to think that way. [UP1-, UP2-, UP3+]
- h. ↓Mary assumes that logical thought is necessary. Peter does so too. [UP1-, UP2-, UP3-]

<sup>3</sup>In order to clarify examples, I wavy underline the noncontrastive adjunct when it is present.

Examples with violations of only one of UP1 or UP2 (as in (4a-f)) can be found in corpora, with no intuitively clear decrease in acceptability. However, I have not been able to find examples violating both preferences and there is an intuitively strong decrease in acceptability in constructed examples of this type (as in (4g,h)). On the other hand, one can find examples violating either of UP1 or UP2, conjointly with a violation of UP3 (as in (4e,f)), and this does not seem to lead to an intuitively clear decrease in acceptability.<sup>4</sup> I therefore suggest that UP1 and UP2 are STRONG Usage Preferences whereas UP3 is a WEAK Usage Preference. This appears to correlate with the much stronger statistical strength of UP1 and UP2 in corpus data (98% as opposed to the 83% found for UP3). Violation of two strong UPs thus appears to lead to unacceptability.

## 2.2 A functional explanation for UP3

Let us now have a closer look at UP3. Consider what happens to examples like (4a,c), where UP2 is satisfied, and UP3 is as well, if one removes the non-contrastive adjunct, as illustrated in (5a,b):

- (5)
- a. What is most important, in the end, is to make sure that the president makes the right decisions, that #he does so, and that they are implemented effectively.
  - b. We assume that logical thought, syllogistic analytical reason, is the necessary, right thought—and #we do so.

Because the sentence with the anaphor refers to the same state of affairs as its antecedent, removing the noncontrastive adjunct leads to simple tautologous repetition of the previous content and thus to infelicity because of the violation of Grice's maxim of quantity.

On the other hand, an example like (4b), which does not respect UP3 (but does respect UP1 and UP2), does not have the same tautologous status because a second reference to the same state of affairs is made in order to temporally locate another event. All of the examples which do not satisfy UP3 in Miller 2011's sample are in fact of this type, and it is very clearly the overwhelmingly most frequent case of UP3 violations in corpus data. We thus see that UP3 has an obvious functional explanation, given UP2.

## 2.3 Motivations for UP1 and UP2?

By contrast with UP3, UP1 and UP2 seem much less obviously amenable to some sort of functional explanation. UP1 might be thought to stem from the fact that *do so* contains main verb *do*, which is not a stative verb (except in certain idiomatic uses), as has often been suggested in the literature. This idea provides an intuitively

<sup>4</sup>As discussed in the next section, certain violations of UP3 can lead to strong unacceptability because they violate the maxim of quantity.

satisfying explanation for the fact that *do it*, *do this*, and *do that* are clearly much more strongly unacceptable with stative antecedents, as shown by the variants of (2) and (4c).

- (6) a. ... whenever the relation of complementary distribution holds between phones belonging to a common phoneme, #it does it/this/that because ...
- b. We assume that logical thought, syllogistic analytical reason, is the necessary, right thought—and #we do it/this/that because ...

The problem is that if *do so* were synchronically compositional, one would expect to get as strong a resistance to stative antecedents as one finds with *do + it/this/that*, which *can* be argued to be compositional. So at best, UP1 can be explained as a synchronic dispreference inherited from a putative previous situation where *do so* was compositional. As for UP2, it is hard to see what kind of functional (or other) explanation might explain it. In particular, an analysis in terms of performance difficulties seems hard to imagine.

To conclude, it appears that UPs may not always be synchronically motivated. Of course, stating a UP is always an invitation to attempt to provide some sort of more general explanation for it (as was suggested above for UP3). But we must be ready to accept that some UPs might lack any relevant motivation, at least provisionally, and still have additive effects on acceptability.

### 3 UPs and grammaticality

#### 3.1 Acceptability and grammaticality

If one assumes that there exists a specifically linguistic set of cognitive capacities (innate or not), which we can call linguistic competence and which is not reducible to more general cognitive capacities, then one of the central goals of linguistic theory must necessarily be to provide a model of this linguistic competence. In order to do this, we need to have hypotheses about what it is we are supposed to model. If we are working in syntax and semantics, it means that we need to have hypotheses about what are the syntactically and semantically well-formed strings of the language. This requires, in turn a set of hypotheses about performance.

In early work, Chomsky suggested that one should base one's theory of competence on an analysis of the cases where grammaticality and ungrammaticality were obvious and that "in many intermediate cases we shall be prepared to let the grammar itself decide, when the grammar is set up in the simplest way so that it includes the clear sentences and excludes the clear non-sentences" (Chomsky 1957:14). However, very quickly, generative linguists began to use intuitive judgments of grammaticality on sentences for which such judgments were far from obvious as crucial evidence in arguing for one theory over another, rather than "letting the grammar itself decide" in such cases. The dangers of this methodology

have been clearly pointed out by numerous authors, as early as Schütze 1996 (see Gibson & Fedorenko 2013 for a recent discussion and Sprouse & Almeida 2013 for an opposing point of view.)

Many linguists (including many in the HPSG community) have tried to improve the reliability of grammaticality judgments, both by using corpus evidence and psycholinguistic experiments, in order to provide a more solid basis for establishing the domain of well-formed items that we have to model. These studies have made it clear that acceptability is a gradient notion. The question remains open as to how the gradience of acceptability connects to grammaticality. Possible hypotheses (these are not mutually incompatible) include:

- i. Grammatical sentences can be less than fully acceptable and can even be completely unacceptable.
- ii. Grammaticality is a gradient property.
- iii. Ungrammatical sentences may be acceptable.

The first of these positions is as old as generative grammar and is commonly accepted as necessary. The classical example of this type is that performance limitations can make a grammatical sentence unacceptable. The second is upheld by many proponents of probabilistic theories of grammar, corpus linguistics and cognitive grammar.<sup>5</sup> The third position has been proposed by Lyn Frazier and her collaborators (see e.g. Arregui et al. 2006), who call it the ‘recycling hypothesis’). They claim that hearers can ‘repair’ ungrammatical sentences and that the degree of perceived acceptability will depend on the complexity of the repair process (see Kertz 2013 and Miller & Hemforth 2013 for arguments against this position). This leads them to conclude that even very simple ungrammatical sentences can be judged to be acceptable.<sup>6</sup>

I follow Schütze 1996, Pullum & Scholz 2001 and Gibson & Fedorenko 2013 in taking position (i) and considering that there is a well-defined, non gradient notion of grammaticality but that various factors may intervene, making grammatically well-formed structures unacceptable. Specifically, I would like to argue here that multiple violations of UPs can lead to this result.

### 3.2 The down arrow (↓) judgment

Let us come back to the grammaticality status of the sentences in (4). I claim that all of these examples must be considered to be grammatical. If one does not accept

---

<sup>5</sup>See e.g. Pullum & Scholz 2001:26ff for discussion and references. They argue that grammaticality cannot be gradient—either grammatical constraints are satisfied or they are not—but that ungrammaticality is gradient: the more rules and/or constraints are violated, the higher the degree of ungrammaticality and consequently of unacceptability. This position seems entirely plausible to me.

<sup>6</sup>Gibson & Thomas 1999, on the other hand, show that performance mistakes can in some cases lead native speakers to judge complex ungrammatical sentences to be acceptable. This is compatible with the position taken here.

this conclusion, one of the two following positions must be assumed. Either one considers UP1, UP2, and UP3 to be constraints on grammaticality, so that all of the sentences in (4) where any of these UPs is violated, i.e. all of them except (4a), must be considered as ungrammatical. Since there does not seem to be anything especially complex about them which might lead to a performance mistake, one must adopt some position similar to Frazier's recycling hypothesis to explain why some of these are acceptable. Or one must assume that combining violations that do not individually lead to ungrammaticality can lead to ungrammaticality. This position seems to necessitate some form of gradient notion of grammaticality, which we have rejected.

I therefore suggest that we need a new type of judgment characterizing sentences which do not violate any principles of grammar but which are unacceptable because they cumulatively violate different UPs. I suggest using the down arrow ( $\downarrow$ ) to mark these sentences, as was done in (4g,h).

### 3.3 Methodological importance of UPs

Lakoff & Ross 1976 were the first to discuss *do so* in the generative literature. Because the prototype examples for PAE in the literature were cases with contrastive subjects and *too* (e.g. *Mary likes apples and Jane does too*) and *do so* was thought to be a variant of PAE, Lakoff and Ross's invented examples of *do so* typically involved contrasting subjects. Specifically, out of 33 example sentences with *do so*, 27 have contrasting subjects. Among these are ALL of the sentences that they use to argue that *do so* cannot have stative antecedents, as in (7a). This should be contrasted with the variant of their sentence given in (7b), which satisfies UP1 and UP3, and which intuitively seems much more acceptable.

- (7) a. \*Bill knew the answer, and Harry did so, too. (p.105, (8), their judgment).
- b. Bill knew the answer. He did so because he had read an article on the subject in the paper the day before.

Since Lakoff & Ross 1976, this unnatural pattern of usage has made its way into many articles and textbooks, in arguments for VP constituency and for the complement/adjunct distinction, e.g. Radford 1988:234, (23), (24); Haegeman 1991:81-82, (14), (15); Haegeman & Guéron 1999:69, (123), (124), (125); Sobin 2008 (out of 32 examples of *do so*, 26 have contrasting subjects). In all of these cases, it can be argued that the grammaticality judgments (and the results of the tests that are based on them) are strongly compromised because the baseline of the examples does not respect UP2, so that any further preference violation can lead to strong intuitions of unacceptability, possibly independently of any grammaticality problems.

Similarly, not taking UPs sufficiently into account in psycholinguistic experimentation can lead to noise in the results, making them much less statistically

significant. For instance, the materials set up by Houser 2010 to test the acceptability of stative antecedents for *do so* do not control for the identity of subjects and states of affairs, so that some of his stimuli satisfy UP2, but others do not. Similarly, some stimuli have a non contrastive adjunct, satisfying UP3, and others do not. From his discussion of his results, it appears that Houser is a bit disappointed by the weakness of the effects he finds. It is likely that part of this is due to the noise created by not paying sufficient attention to usage preferences.

## 4 Acceptability experiments for *do so*

### 4.1 Experiment 1

The UPs for *do so* discovered through corpus research, stated above in (3), suggest clear predictions for acceptability experiments. Stimuli respecting all UPs should be the most acceptable; stimuli violating several UPs should be less acceptable than those violating only one; and stimuli violating the two strong UPs (UP1 and UP2) should be less acceptable than those violating a strong UP and UP3 (which we suggested was weak). In order to test the predictions an acceptability experiment was run on Amazon's Mechanical Turk. Items were constructed on the basis of three binary factors, corresponding to UP1, UP2, and UP3:

- I. Eventive vs. stative antecedent [Evt/St]
- II. Same subject vs. different subject [SSubj/DSubj]
- III. Non contrastive adjunct vs. no adjunct[Adj/NoAdj]

Here is a typical item in its eight conditions:

- Event
  1. The President of the Senate obtained bipartisan support on this issue. He did so thanks to hours of painstaking negotiations with influential members. [Evt, SSubj, Adj]
  2. The President of the Senate obtained bipartisan support on this issue. The press has reported that he did so. [Evt,SSubj,NoAdj]
  3. The President of the Senate obtained bipartisan support on this issue. The Speaker of the House did so as well, thanks to hours of painstaking negotiations with influential members. [Evt,DSujb,Adj]
  4. The President of the Senate obtained bipartisan support on this issue. The Speaker of the House did so as well. [Evt,DSujb,NoAdj]
- State



5. The President of the Senate has bipartisan support on this issue. He does so thanks to hours of painstaking negotiations with influential members. [St,SSubj,Adj]
6. The President of the Senate has bipartisan support on this issue. The press has reported that he does so. [St,SSubj,NoAdj]
7. The President of the Senate has bipartisan support on this issue. The Speaker of the House does so as well, thanks to hours of painstaking negotiations with influential members. [St,DSubj,Adj]
8. The President of the Senate has bipartisan support on this issue. The Speaker of the House does so as well. [St,DSubj,NoAdj]

## Methods

40 items were constructed. They were distributed across 8 lists following a Latin Square design, randomly mixed with 56 distractors.<sup>7</sup> 160 participants were asked to judge the acceptability of the second sentence (explained in terms of naturalness of the second sentence as a continuation of the first) on a 7 point scale. The experiment was run using Amazon's mechanical turk and the Ibex platform for online experiments.

We modelled the data using linear mixed effect models with EVENT, SUBJECT and ADJUNCT as fixed effects and random effects (including intercept and slope) for Participant and Item. The contribution of each interaction and main effect was assessed using likelihood-ratio tests.

## Results

Acceptability ratings per condition, with error bars, are presented in figure 1.

There was a significant main effect of event ( $\text{Chi}^2(1) = 44.17, p < .001$ ), indicating that events were rated higher than states. The main effect of subject was also significant ( $\text{Chi}^2(1) = 9.02, p < .01$ ). Here, sentences with different subjects were rated higher than those with the same subject. There was also a significant main effect of adjunct ( $\text{Chi}^2(1) = 5.18, p < .05$ ) indicating that sentences with adjunct were rated higher than those without adjunct

The two-way interaction between event and subject was significant ( $\text{chi}^2(1) = 10.07, p < .01$ ), which was due to a smaller difference between event and state within the different subject condition than within the same subject condition. The two-way interaction between event and adjunct was also significant ( $\text{chi}^2(1) = 4.44, p < .05$ ), which was due to a smaller difference between event and state within the adjunct conditions. The two-way interaction between subject and adjunct was highly significant ( $\text{chi}^2(1) = 79.02, p < 0.001$ ). Here pairwise comparisons revealed that within

<sup>7</sup>In order to maximize the dispersion of the acceptability judgments on the materials of this experiment, in which none of the conditions are strongly unacceptable, distractors were chosen so as not to contain anything strongly unacceptable.

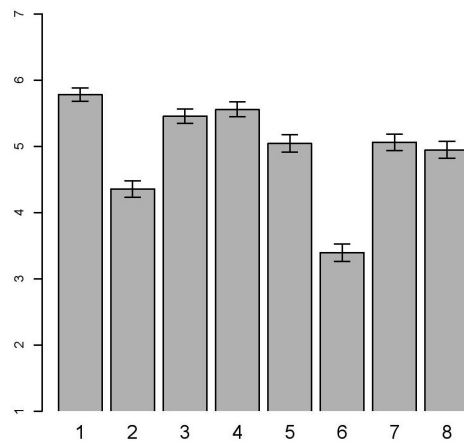

Figure 1: Acceptability ratings per condition

the adjunct condition, same subject was rated slightly higher than different subject, while within no adjunct, different subject was rated higher than same subject. This is illustrated in figure 2.

The three-way interaction was not significant ( $\chi^2(1) < 1$ ), which indicates that the two-way interactions were independent of the third factor.

## Discussion

Results for the event vs. state factor were as expected. Mean acceptability for the four event conditions was 5.29 whereas for the four state conditions it was 4.6. This should be compared with Houser 2010:66 who finds a median acceptability rating of 6 for activity predicates and of 3 for states (also on a 7 point scale). The difference may be due in part to the choices of stative predicates and also to the fact that the stimuli used here were more natural than those used by Houser. It may also be due to the level of education of the participants, as discussed below.

On the other hand, results for the same subject vs. different subject factor were completely unexpected. Sentences with same subjects were judged less acceptable on average (4.64) than those with different subjects (5.25). Several hypotheses can be considered to explain the difference between these results and the expectations stemming from the corpus data.

First, it may be the case that the sample studied by Miller 2011 was not representative. Further corpus analysis is required to see if this is in fact the case. Though a detailed analysis is beyond the scope of this paper, it was possible to use search heuristics on the COCA to corroborate the idea that *do so* disprefers contrasting subjects. Figure 3 provides the number of occurrences of *do so*, *do it* and PAE with *do*, followed by an optional comma and either *too* or *as well* and a period.<sup>8</sup> The second column provides the raw number of occurrences in the COCA;

<sup>8</sup>In order to ensure that only finite forms were being counted, only the forms *does* and *did* were

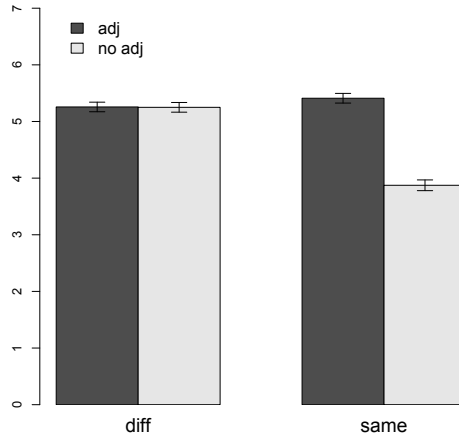

Figure 2: Acceptability ratings for different and same subjects with and without an adjunct

Pattern	N of occ	%	overall % in COCA
does/did so (,) too/as well .	18	2.65%	12%
does/did it (,) too/as well .	33	4.85%	8%
does/did (,) too/as well .	697	92.5%	80%
Total	748	100%	100%

Figure 3: Comparative frequency of *do so*, *do it* and PAE with contrasting subjects in the COCA

the third column gives the percentage of occurrences of each anaphor in the *too/as well* context and the fourth column gives the percentage of occurrences of each anaphor overall in the COCA (as reported in Miller 2011). It appears that PAE is the preferred construction in these contexts, occurring more frequently than overall in the COCA. On the other hand, both *do so* and *do it* are less frequent in this context than overall. Specifically, it appears that *do so* is four to five times less frequent in this context than it is overall in the COCA. This discussion is only meant to be suggestive. It includes a bit of noise and covers only one subcase of the different subject condition. Further detailed corpus analysis is required to shed more definitive light on the situation.

Second, the sentence pattern used in conditions 2 and 6 (the same subject/no adjunct conditions) appears to be a highly unnatural use of *do so*, and these stimuli were judged by far the least acceptable (mean ratings of 4.35 for condition 2 and of 3.39 for condition 6). On the other hand, both sentence patterns used in the

---

included in the search.

different subject conditions appear to be equally acceptable. It is thus tempting to neutralize conditions 2 and 6. This could be done by replacing the results for conditions 2 and 6 by conditions 1 and 5 respectively. This leads to a mean of 5.41 for the same subject condition and of 5.25 for the different subject condition. Or one might simply prefer to reduce the comparison to the conditions with adjuncts, which gives essentially the same results (5.41 for the same subject condition and 5.26 for the different subject condition). Better test materials must be constructed, avoiding the pattern used in conditions 2 and 6, in order to see if these hypotheses are on the right track. Specifically, this condition should have been tested using examples of the type illustrated in (4b), which, as mentioned above, are the typical instances of this case found in corpora.

A third hypothesis involves consideration of the level of education of the participants. In this experiment, I did not think to include a question on this. However a question on level of education was asked in a subsequent experiment and showed that 65.6% of participants had completed elementary school, .6% had completed junior highschool and 33.8% had completed highschool. There were no college graduates. This is potentially very important as Miller 2011 shows that register is a very significant factor in the use of *do so*: it is 13.5 times more frequent in the academic part of the COCA than in the spoken and fiction parts. It is thus possible that the typical participants in Amazon mechanical turk experiments are simply not sufficiently familiar with the usual use of *do so* to make the same acceptability judgments as speakers familiar with academic English. This might explain an overall bias towards high acceptability in this experiment (since *do so* might overall be interpreted as a marker of higher register and thus an example of “good speech”). It may also partly explain the difference between judgments of *do so* with stative antecedents in this experiment and in Houser’s: since his participants were college undergraduates they can be presumed to be more familiar with academic English and might thus be more sensitive to UP1. On the other hand, the probable lack of familiarity with academic English of the Amazon mechanical turk participants might lead to a reduced capacity to discriminate between natural and unnatural uses.

In the light of this suggestion, one might wonder why there would be a difference between the same/different subject factor (UP1) and the event/state factor (UP2). Why should Amazon mechanical turk participants be sensitive to the former, but not to the latter? A hypothesis here might be linked to the presence of main verb *do* and its eventive semantics (cf. section 2.3). This is shared by *do it*, *do this* and *do that*, which are register neutral. The relevance of the distinction between stative and eventive can thus be expected to be at least partly accessible to speakers unfamiliar with academic English, given the obvious main verb status of *do* in *do so*. On the other hand, the same subject constraint is not shared by the other verbal anaphors based on main verb *do* and speakers unfamiliar with academic English might be completely unaware of it. As mentioned in section 2.3, UP2 does not seem to have any obvious independent motivating factors that would allow it to be inferred by speakers unfamiliar with the usual uses of *do so*. In order to evaluate

this hypothesis, similar experiments will have to be conducted on a population of participants who are users of academic English.

## 4.2 Experiment 2

In the presentation of the results of experiment 1 at the HPSG conference, I suggested that register compatibility might be one reason for the difference in perceived acceptability between the examples proposed by Lakoff & Ross 1976 and Culicover & Jackendoff 2005 (cf. (7a) and (1a,b)) and the similar experimental materials of conditions 3,4,7,8 with contrasting subjects. Indeed, in the experimental materials, I chose to use *as well*, which is marked for higher register and thus very compatible with *do so*, rather than *too*, which is not clearly register marked.<sup>9</sup> Participants at the HPSG conference and other linguists I consulted felt that replacing *too* by *as well* led to a significant increase in the acceptability of the Lakoff & Ross and Culicover & Jackendoff examples.

In order to test the relevance of these observations, an experiment was run on Amazon's mechanical turk. Items were constructed on the basis of two binary factors:

- I. Event vs. state [Evt/St]
- II. *too* vs. *as well* [too/as well]

Here is a typical item in its four conditions:

1. A.—Kate read the book. B.—Karen did so too. [Evt/too]
2. A.—Kate read the book. B.—Karen did so as well. [Evt/as well]
3. A.—Kate owned an apartment. B.—Karen did so too. [St/too]
4. A.—Kate owned an apartment. B.—Karen did as well. [St/as well]

## Methods

20 items were constructed. They were distributed across 4 lists following a Latin Square design, randomly mixed with 60 distractors. 80 participants were asked to judge the acceptability of the B's response (explained in terms of its naturalness as a response to A's initial statement) on a 7 point scale.

<sup>9</sup>A more detailed look at the corpus data reported in the table presented in figure 3 suggests that this is on the right track. The following table distinguishes the cases of *too* and *as well* initially grouped in column 2:

Pattern	N of occ	<i>too</i>	<i>as well</i>
does/did so (,) too/as well .	18	5	13
does/did it (,) too/as well .	33	30	3
does/did (,) too/as well .	697	629	68
Total	748	664	84

It appears that while *as well* is on the order of 10 times less frequent than *too* with PAE and *do it*, it is more frequent with *do so*.

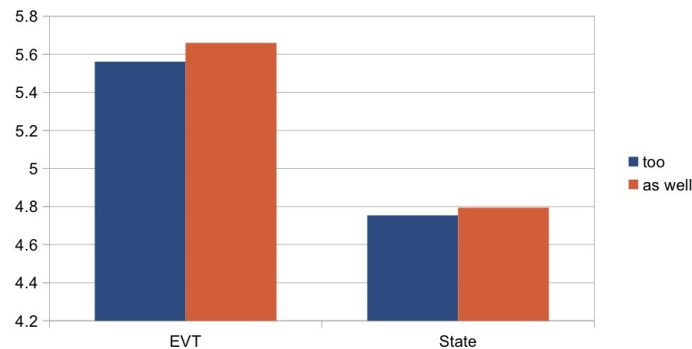

Figure 4: Acceptability ratings for Evt/St and *too* vs. *as well*

## Results

The results are shown in figure 4. Once again items with event antecedents were judged to be significantly more acceptable (mean: 5.6) than with state antecedents (mean: 4.78). This effect was highly significant ( $\chi^2(1)=17.245, p<.001$ ). However there was no significant main effect of *too*/*as well* ( $p>.24$ ).

## Discussion

The experiment further corroborates the relevance of the event/state distinction for antecedents of *do so*. However, contrary to expectations, no effect of the choice between *too* and *as well* was found. As with experiment 1, this might be a consequence of the probable lack of familiarity of the participants with academic English. Further experiments on subjects who *are* familiar with academic English are necessary to corroborate this conjecture.

## 5 Some remarks on nonfinite *do so*

The corpus data and experiment reported in Houser 2010 shows that the effect of stativity on acceptability is reduced when *do so* is in a nonfinite form. Houser follows up on a suggestion of Huddleston et al. 2002 that this is due to the impossibility of PAE in these contexts.<sup>10</sup>

Miller 2011 points out that the proportion of nonfinite over finite uses of *do so* in the COCA can be estimated to be much higher than for other common verbs, so that nonfinite forms are strongly overrepresented. Specifically, *to do so* is four times more frequent in the COCA than one would expect, given the frequency of

<sup>10</sup>Certain varieties of British English allow what is apparently auxiliary *do* to appear in nonfinite contexts, e.g. (i) So far, everything that could go wrong has done. (*The Guardian*, 26/05/2001, I thank L. Haegeman for this example); (ii) —Does Mr Charley Newton live here? —He might do (BBC, *Westway*, 23 nov 2001). Such examples are impossible in American English.

finite *do so* and the average proportion of finite to non finite uses for high-frequency verbs.

This suggests that we are confronted here with a typical Saussurean systemic effect: for two constructions A (PAE) and B (*do so*) that are in competition in an environment E (finite clauses), if B can occur in a environment E' that precludes A (nonfinite clauses), UPs that favor A over B in E will lead to reduced unacceptability if they are violated in E'. Houser 2010 provides another example of this type of Saussurean systemic effect illustrated in the following constructed example:

- (8) a. The students who know French best do so because they lived in France for a year. (Houser 2010:4,(8b))
- b. \*The students who know French best do because they lived in France for a year.

He points out that when the antecedent of *do so* is in a relative clause on the subject of *do so* then alternation with PAE is once again impossible. His experimental results show a significant improvement in the acceptability of sentences with stative antecedents in this configuration.

## 6 Conclusion

In this paper, I have tried to argue that it is necessary to take Usage Preferences into account when analyzing linguistic phenomena. Since these preferences govern verbal behavior, they must be taken to be part of linguistic competence, and as such are a necessary part of any complete analysis of a speaker's knowledge of language. On the other hand, I have argued that violating UPs does not affect grammaticality. However, it appears that acceptability judgments *can* be affected by not respecting UPs and, more specifically, that the effects of UP violations can be additive (as it has been argued that UPs do not necessarily result from performance difficulties, this provides a further case of additive effects beyond those linked to performance problems, such as those discussed in Hofmeister et al. 2014)). It is therefore methodologically very important to take Usage Preferences into account, both when using introspective acceptability judgments and when setting up experimental materials. One of the flaws that make the results of experiment 1 reported above difficult to interpret is precisely that I did not follow my own advice, using a dispreferred sentence type as materials in two conditions.

I have also suggested that UPs might be divided into strong and weak UPs. One might speculate that such a binary distinction is not sufficient and that what is needed is continuous statistical weighting of UPs, which might be directly linked to their statistical strength in language use. The effects on acceptability of multiple violations of UPs might then be predictable on the basis of some combinatorics based on the weighting of the UPs involved, the exact nature of which is left for further investigation.

The line of investigation proposed here can be understood as a strategy for dealing with the gradience of acceptability judgments (see e.g. Keller 2001, Sorace & Keller 2005) on a basis similar to much current work on probabilistic approaches to grammar (see e.g. Bod et al. 2003, Manning 2003, Bresnan 2007). However, contrary to much work that takes grammaticality itself to be a gradient property, I have tried to suggest an approach which accounts for gradience of acceptability based on a nongradient conception of grammaticality, explaining differences in acceptability between equally grammatical sentences on the basis of a calculus of UPs.

Another important conclusion of the study is the importance of register (which might itself be modeled in terms of UPs) and of the fact that different groups of speakers might not be equally competent in all registers (an idea which will be obvious to sociolinguists).

The idea of UPs may not at first sight be appealing to many specialists of theoretical syntax and semantics. There seems to be something unsatisfying about simple stipulatory statements about usage. Obviously, anyone would prefer to be able to explain any observed UP on the basis of more general properties (as was suggested for UP3 in section 2.2 above). This leads to two observations. First, in order to even raise the question of explaining a UP it is necessary to have observed it. This in and of itself makes the study of such UPs relevant, as they raise intriguing questions for theoretical studies. Second, even if it turns out that a UP is not amenable to any more general synchronic explanation, it is still a part of linguistic competence, and as such must be described in any complete theory of knowledge of language. It is also crucial to take them into account in order to avoid mistakenly classifying as ungrammatical structures that are in fact only dispreferred.<sup>11</sup>

## References

- Arregui, Ana, Charles Clifton Jr., Lyn Frazier & Keir Moulton. 2006. Processing elided verb phrases with flawed antecedents: The recycling hypothesis. *Journal of Memory and Language* 55. 232–246.
- Bod, Rens, Jennifer Hay & Stefanie Jannedy. 2003. *Probabilistic syntax*. Cambridge, MA: MIT Press.
- Bresnan, Joan. 2007. A few lessons from typology. *Linguistic Typology* 11(1). 297–306.
- Chomsky, Noam. 1957. *Syntactic structures*. The Hague: Mouton.

---

<sup>11</sup>See Payne et al. 2013 who argue that one must distinguish being ungrammatical and being a dispreferred alternate of another construction, arguing that a classical unacceptable example like *the one of physics* is simply dispreferred with respect to *the physics one* and that it is the existence of a preferred alternate which causes the dispreferred one to be felt to be unacceptable.



- Culicover, Peter & Ray Jackendoff. 2005. *Simpler syntax*. Oxford: Oxford University Press.
- Davies, Mark. 2008-. The corpus of contemporary american english: 450 million words, 1990-present. <http://corpus.byu.edu/coca/>.
- Gibson, Edward & Evelina Fedorenko. 2013. The need for quantitative methods in syntax and semantics research. *Language and Cognitive Processes* 28. 88–124.
- Gibson, Edward & James Thomas. 1999. Memory limitations and structural forgetting: The perception of complex ungrammatical sentences as grammatical. *Language and Cognitive Processes* 14. 225–248.
- Haegeman, Liliane. 1991. *Introduction to government and binding theory*. Oxford: Blackwell.
- Haegeman, Liliane & Jacqueline Guéron. 1999. *English grammar: A generative perspective*. Oxford: Blackwell.
- Hankamer, Jorge & Ivan A. Sag. 1976. Deep and surface anaphora. *Linguistic Inquiry* 7. 391–426.
- Hardt, Daniel. 1993. *Verb phrase ellipsis: Form, meaning, and processing*: University of Pennsylvania dissertation. Distributed as IRCS Report 93-23.
- Hofmeister, Philip, Laura Staum Casasanto & Ivan A. Sag. 2014. Processing effects in linguistic judgment data: (super-)additivity and reading span scores. *Language and Cognition* to appear.
- Houser, Michael John. 2010. *The syntax and semantics of do so anaphora*. Berkeley, CA: University of California, Berkeley dissertation.
- Huddleston, Rodney, Geoffrey K. Pullum et al. 2002. *The Cambridge grammar of the English language*. Cambridge: Cambridge University Press.
- Johnson, Kyle. 2001. What VP ellipsis can do, and what it can't, but not why. In Mark Baltin & Chris Collins (eds.), *The handbook of contemporary syntactic theory*, 439–479. Cambridge: Blackwell.
- Kehler, Andrew. 2002. *Coherence, reference, and the theory of grammar*. Stanford: CSLI Publications.
- Keller, Frank. 2001. *Gradience in grammar: experimental and computational aspects of degrees of grammaticality*. Edinburgh: University of Edinburgh dissertation.
- Kertz, Laura. 2013. Verb phrase ellipsis: The view from information structure. *Language* 89. 390–428.

- Lakoff, George & John Robert Ross. 1976. Why you can't do so into the sink. In James D. McCawley (ed.), *Syntax and semantics 7: Notes from the linguistic underground*, 101–111. New York: Academic Press. First semipublished in 1966.
- Manning, Christopher D. 2003. Probabilistic syntax. In Rens Bod, Jennifer Hay & Stefanie Jannedy (eds.), *Probabilistic linguistics*, 289–341. Cambridge, MA: MIT Press.
- Michiels, Archibald. 1978. A note on the relation between agent and stativity. *Neophilologus* 62. 172–177.
- Miller, Philip. 2011. The choice between verbal anaphors in discourse. In I. Hendrickx, S. Lalitha Devi, A. Branco & R. Mitkov (eds.), *Anaphora processing and applications: 8th discourse anaphora and anaphor resolution colloquium, daarc 2011*, vol. 7099 Lecture Notes in Artificial Intelligence, 82–95. Berlin: Springer.
- Miller, Philip & Barbara Hemforth. 2013. Verb phrase ellipsis with nominal antecedents. Ms. Université Paris Diderot.
- Payne, John, Geoffrey K. Pullum, Barbara C. Scholz & Eva Berlage. 2013. Anaphoric *one* and its implications. *Language* 89. to appear.
- Pullum, Geoffrey K. & Barbara C. Scholz. 2001. Model-theoretic and generative-enumerative syntactic frameworks. In Philippe de Groote, Glyn Morrill & Christian Retoré (eds.), *Logical aspects of computational linguistics*, 17–43. Berlin: Springer.
- Radford, Andrew. 1988. *Transformational grammar: A first course*. Cambridge: Cambridge University Press.
- Sag, Ivan A. 1976. *Deletion and logical form*. Cambridge, MA: MIT dissertation.
- Schachter, Paul. 1978. English pro predicates. *Linguistic Analysis* 4. 187–224.
- Schütze, Carson T. 1996. *The empirical base of linguistics: Grammaticality judgments and linguistic methodology*. Chicago: University of Chicago Press.
- Sobin, Nicolas. 2008. *Do so* and VP. *Linguistic Inquiry* 39. 147–160.
- Sorace, Antonella & Frank Keller. 2005. Gradience in linguistic data. *Lingua* 115. 1497–1524.
- Sprouse, Jon & Diogo Almeida. 2013. The empirical status of data in syntax: A reply to Gibson and Fedorenko. *Language and Cognitive Processes* 28. 222–228.

# Passive in Danish, English, and German

Stefan Müller 

Freie Universität Berlin

Bjarne Ørsnes 

Freie Universität Berlin

Proceedings of the 20th International Conference on  
Head-Driven Phrase Structure Grammar

Freie Universität Berlin

Stefan Müller (Editor)

2013

Stanford, CA: CSLI Publications

pages 140–160

Keywords: passive, Danish, English, German, impersonal passive, case

Müller, Stefan & Bjarne Ørsnes. 2013. Passive in Danish, English, and German.  
In Stefan Müller (ed.), *Proceedings of the 20th International Conference on Head-Driven Phrase Structure Grammar*, Freie Universität Berlin, 140–160. Stanford, CA: CSLI Publications. DOI: 10.21248/hpsg.2013.8. 

## Abstract

We show how variation in the passive in Danish, English, and German can be accounted for. The three languages differ along the following dimensions:

- the existence of a morphological passive in Danish
- a subject requirement in Danish and English resulting in expletive insertion in impersonal constructions in Danish and absence of impersonal passives in English
- the possibility to promote the secondary object to subject in Danish

The differences are accounted for by differences in the structural/lexical case distinction and by mapping processes that insert expletives in Danish. The passive in general is accounted for by a lexical rule that is uniform across languages and hence captures the generalization regarding passive.

## 1 The Phenomenon

In the following subsections we examine various properties of passives in which Danish, English, and German differ. We look at the morphological passive in Danish in Section 1.1, compare the personal and impersonal passives in the three languages in Section 1.2, and examine the possibility to promote the objects in passives of ditransitive constructions in Section 1.3.

### 1.1 Morphological and Analytic Forms

Danish has two basic variants of passives. The first one is an analytic form with the auxiliary *blive* and a participle (1b) and the second one is a morphological passive that is formed with the suffix *-s* (1c,d). (1c) shows an example of the passive in the present tense form and (1d) shows one in the past tense form:

- (1) a. Peter læser avisen.  
Peter reads newspaper.DEF  
'Peter is reading the newspaper.'
- b. Avisen bliver læst af Peter.  
newspaper.DEF is read by Peter  
'The newspaper is read by Peter.'
- c. Avisen læses af Peter.  
newspaper.DEF read.PRES.PASS by Peter  
'The newspaper is read by Peter.'
- d. Avisen læstes af Peter.  
newspaper.DEF read.PAST.PASS by Peter  
'The newspaper was read by Peter.'

The morphological passive may also apply to infinitives:

- (2) Avisen skal læses hver dag.  
 newspaper.def must read.INF.PASS every day  
 ‘The newspaper must be read every day.’

The morphological passive and its analytical counterpart are not equal in their distribution (see for instance Bjerre & Bjerre, 2007 and Engdahl, 2001), but we will not discuss the differences here.

English and German do not have morphological passives. The only possible forms are the analytic ones that are shown in (3):

- (3) a. The paper was read.  
 b. Der Aufsatz wurde gelesen.  
 the paper.NOM was read

## 1.2 Personal and Impersonal Passives

We already saw instances of the personal passive in (1b) and (3). The subject in personal passives can be an NP as in (1b–d) and (3) or a clause as in (4a) or an infinitival VP as in (4b).

- (4) a. At regeringen træder tilbage, bliver påstået.  
 that government.DEF resigns PART is claimed  
 ‘It is claimed that the government resigns.’  
 b. At reparere bilen, bliver forsøgt.  
 to repair car.DEF is tried  
 ‘It is tried to repair the car.’

The following example from Dalrymple & Lødrup, 2000, p. 108 shows that sentential objects can be promoted to subject in English too:

- (5) That the earth is round was not believed.

Often, however, sentential subjects are extraposed and an expletive *it* takes the subject position as in the translations of the Danish examples in (4).

As Dalrymple & Lødrup (2000, p. 109) point out, there are verbs that take a sentential complement and allow for a passive with *it* together with a sentential complement without allowing a passive with a sentential subject.

- (6) a. It was hoped that it would rain.  
 b. \* That it would rain was hoped.

It is interesting to note that verbs like *hope* do not take NP objects (7) and hence analyses that try to analyze (6a) as an instance of the passive of the pattern *NP was verb* in which the NP slot is filled by *it* + extraposed clause are not viable.

- (7) \* I hoped it.

Apart from personal passives, German and Danish allow for impersonal ones. (8) shows German examples and (9) the Danish analogues.

- (8) weil noch gearbeitet wird  
 because still worked is  
 ‘because there is still working there’
- (9) a. fordi der bliver arbejdet  
 because EXPL is worked  
 ‘because there is working’  
 b. fordi der arbejdes  
 because EXPL work.PASS  
 ‘because there is working’

Danish differs from German in requiring an expletive subject pronoun. Without the expletive pronoun the sentences in (9) are ungrammatical, as (10) shows:

- (10) a. \*fordi bliver danset  
 because is danced  
 b. \*fordi danses  
 because dance.PASS

German on the other hand does not permit an expletive as (11) shows:<sup>1</sup>

- (11) \*weil es noch gearbeitet wird  
 because EXPL still worked is

The reason for this difference is a typological difference between the languages: Danish is an SVO language while German is an SOV language. Danish, like English, requires the subject position to be filled. While English simply does not allow for passives of mono-valent verbs, Danish inserts an expletive subject. English passivizations like (6a) are special since the sentential complement is not realizable as subject but an expletive is inserted.

The examples in (8) and (9) show passives of mono-valent verbs but of course bi-valent intransitive verbs like the German *denken* (‘think’) and Danish *passé* (‘take care of’) also form impersonal passives:

- (12) dass an die Männer gedacht wurde  
 that PREP the men thought was  
 ‘that one thought about the men’
- (13) a. at der passes på børnene  
 that EXPL take.care.of.PRES.PASS on children.DEF  
 ‘that somebody takes care of the children’  
 b. at der bliver passet på børnene  
 that EXPL is taken.care.of on children.DEF  
 ‘that somebody takes care of the children’

---

<sup>1</sup>German has expletives, but these are positional expletives that are impossible in verb final clauses. Positional expletives are independent of the passive. On positional expletives in Danish, German, and Yiddish see Müller & Ørsnes, 2011.

### 1.3 Primary and Secondary Objects

While German and English only allow one of the objects to be promoted to subject in passives with the canonical auxiliary (German the accusative, English the primary object, which would be the dative in German), both objects can be promoted to subject in Danish.<sup>2</sup> The following German examples show that the dative object cannot be promoted to subject in passives with *werden*:

- (14) a. weil der Mann dem Jungen den Ball schenkt  
because the man.NOM the boy.DAT the ball.ACC gives.as.a.present  
'because the man gives the boy the ball as a present'
- b. weil dem Jungen der Ball geschenkt wurde  
because the boy.DAT the ball.NOM given.as.a.present was  
'because the boy was given the ball as a present'
- c. \* weil der Junge den Ball geschenkt wurde  
because the boy.NOM the ball.ACC given.as.a.present was  
Intended: 'because the ball was given to the boy as a present'

The same is true for the secondary object (the transferred object) in English: While the primary object can be promoted to subject as in (15a), promoting the secondary object as in (15b) is ungrammatical.<sup>3</sup>

- (15) a. because the boy was given the ball  
b. \* because the ball was given the boy

The intended information structural effect can be achieved though by using the dative shift construction in (16a) and passivizing the verb that takes an NP and a PP object:

- (16) a. because the man gave the ball to the boy  
b. because the ball was given to the boy

Danish allows for the promotion of either argument:

- (17) a. fordi manden giver drengen bolden  
because man.DEF gives boy.DEF ball.DEF  
'because the man gives the boy the ball'
- b. fordi drengen bliver givet bolden  
because boy.DEF is given ball.DEF  
'because the boy is given the ball'
- c. fordi bolden bliver givet drengen  
because ball.DEF is given boy.DEF  
'because the ball is given to the boy'

---

<sup>2</sup>We follow Pollard & Sag (1992, p. 280) in using the terms primary and secondary object rather than direct and indirect object here. The primary object corresponds to the NP that is realized next to the verb in English and the secondary object to the other one. The primary object hence is what usually is called the indirect object, that is, the recipient, which is realized in the dative in German.

<sup>3</sup>Such passivizations are possible in some English dialects. We assume that these dialects can be analyzed in parallel to the analysis of Danish that we suggest below.

## 2 The Analysis

We analyze the passive crosslinguistically as the suppression of the most prominent argument with different possibilities of object promotion. The representation of arguments is discussed in Section 2.1, the lexical rule for argument suppression is discussed in Section 2.2, Section 2.3 deals with the promotion of objects, Section 2.4 with impersonal passives and expletive insertion, and Sections 2.5–2.8 with the passive auxiliary, the morphological passive, the expression of the agent, and the perfect, respectively.

### 2.1 Argument Structure and Valence

We follow Pollard & Sag (1994) in assuming a list-valued feature for the representation of valence information (here ARG-ST). For instance (18a,b) shows the ARG-ST values for the verb *dance* and the transitive verb *read*.

- (18) ARG-ST
- a. *dance* ⟨NP[*str*]⟩
  - b. *read* ⟨NP[*str*], NP[*str*]⟩

The values for the respective Danish and German lexical items are identical.

*str* is the abbreviation for structural case. We follow Haider (1986) in assuming that dative and genitive objects in German have lexical case while nominative and (most) accusative arguments of verbs get their case structurally.

The members of the ARG-ST list are mapped to valence features. For German finite verbs all arguments are mapped to the COMPS list (Pollard, 1996), for English and Danish the first element is mapped to the valence feature for the subject (SPR in our analysis) and the other elements are mapped to the COMPS list (see Pollard & Sag, 1994 on English, see Section 2.4 on impersonals in Danish). Danish and English are SVO languages and the respective dominance schemata will take care of the preverbal realization of the subject and the postverbal realization of the non-subjects. German is an SOV language and allows for the combination of the verb with its arguments in any order, that is, for a verb + subject and object the orders (subj (obj verb)) and (obj (subj verb)) are allowed. This is done by a version of the Head-Complement Schema that does not restrict the order of combination (see Müller, 2013c, p. 130; To appear).

### 2.2 Designated Argument Reduction

We follow the implementation of Haider's ideas (1986) by Heinz & Matiasek (1994) and Müller (2002, Section 3.2; 2003) in assuming a special list-valued feature DESIGNATED ARGUMENT (DA) that contains the designated argument of a verb. The designated argument is the subject of transitive and unergative verbs.



The DA value of unaccusative verbs is the empty list. Passive is analyzed as a lexical rule that applies to a verbal stem and subtracts the DA list from the argument structure list of the input verb or stem. Since we do not focus on the difference between unaccusative and unergative verbs in this paper, we will not discuss the designated argument any further and focus on transitive and unergative verbs instead.<sup>4</sup>

(19) shows the ARG-ST list for *tanzen* ('to dance'), *lesen* ('to read'), *schicken* ('to give as a present'), *helfen* ('to help'):

(19)	ARG-ST	DA
a. <i>tanzen</i> ('dance', unerg):	$\langle \boxed{1} \text{NP}[\textit{str}] \rangle$	$\langle \boxed{1} \rangle$
b. <i>lesen</i> ('read', trans):	$\langle \boxed{1} \text{NP}[\textit{str}], \text{NP}[\textit{str}] \rangle$	$\langle \boxed{1} \rangle$
c. <i>schicken</i> ('give', ditrans):	$\langle \boxed{1} \text{NP}[\textit{str}], \text{NP}[\textit{ldat}], \text{NP}[\textit{str}] \rangle$	$\langle \boxed{1} \rangle$
d. <i>helfen</i> ('help', unerg):	$\langle \boxed{1} \text{NP}[\textit{str}], \text{NP}[\textit{ldat}] \rangle$	$\langle \boxed{1} \rangle$

We follow Meurers (1999) and Przepiórkowski (1999) in assuming that the first element in the ARG-ST list of a verbal head that has structural case gets nominative and all other elements in the ARG-ST list that have structural case get accusative (for a formalization of case assignment see Meurers, 1999; Przepiórkowski, 1999). Lexical case is not affected by passivization, so for instance the dative arguments of *schicken* and *helfen* stay in the dative even when the verb is passivized. (20) shows an example:

- (20) a. weil der Mann ihm geholfen hat  
           because the man.NOM him.DAT helped has  
           'because the man has helped him'
- b. weil ihm geholfen wurde  
           because him.DAT helped was  
           'because he was helped'

(22) shows the result of the application of the participle formation rule in (21):

(21) Lexical rule for the formation of the participle (preliminary):

$$\left[ \begin{array}{l} \text{HEAD} \\ \text{ARG-ST} \\ \textit{stem} \end{array} \begin{array}{l} \left[ \begin{array}{l} \text{DA } \boxed{1} \\ \textit{verb} \end{array} \right] \\ \boxed{1} \oplus \boxed{2} \end{array} \right] \mapsto \left[ \begin{array}{l} \text{ARG-ST } \boxed{2} \\ \textit{word} \end{array} \right]$$

The designated argument is blocked. The ARG-ST list of the participle is either empty or starts with a former object:

---

<sup>4</sup>But see Haider, 1986 and the other quoted literature on unaccusative verbs.

- (22) ARG-ST
- a. getanzt ('danced', unerg):  $\langle \rangle$
  - b. gelesen ('read', trans):  $\langle \text{NP}[\textit{str}] \rangle$
  - c. geschenkt ('given', ditrans):  $\langle \text{NP}[\textit{ldat}], \text{NP}[\textit{str}] \rangle$
  - d. geholfen ('helped', unerg):  $\langle \text{NP}[\textit{ldat}] \rangle$

Since the first element on the ARG-ST list with structural case gets nominative, we have an explanation for the passive in (3b).

The respective argument structures for the English verbs are given in (23):

- (23) ARG-ST
- b. dance (unerg):  $\langle \text{NP}[\textit{str}] \rangle$
  - c. read (trans):  $\langle \text{NP}[\textit{str}], \text{NP}[\textit{str}] \rangle$
  - d. give (ditrans):  $\langle \text{NP}[\textit{str}], \text{NP}[\textit{str}], \text{NP}[\textit{lacc}] \rangle$
  - e. help (trans):  $\langle \text{NP}[\textit{str}], \text{NP}[\textit{str}] \rangle$

English differs from German in not having dative arguments. The object of *help* has structural case just like the object of *read*. This explains the contrast between (20b) and its translation. The NP *ihm* keeps its dative case, that is, it is not realized as a subject. (20b) is an impersonal passive. In English, by contrast, the NP *he* is realized as subject and is assigned nominative. The case of the secondary object of the ditransitive verb *give* is a lexical accusative. This will be explained in the following subsection.

### 2.3 Primary and Secondary Objects

Danish is similar to English in not having a dative case, but it is different from both German and English in allowing the promotion of both objects of ditransitive verbs. We assume that the difference is best captured by assuming that in Danish both objects have structural case while in German and English the secondary object has lexical case. (24) shows the ARG-ST values of the respective Danish verbs:

- (24) ARG-ST
- a. danse ('dance', unerg):  $\langle \text{NP}[\textit{str}] \rangle$
  - b. læse ('read', trans):  $\langle \text{NP}[\textit{str}], \text{NP}[\textit{str}] \rangle$
  - c. give ('give', ditrans):  $\langle \text{NP}[\textit{str}], \text{NP}[\textit{str}], \text{NP}[\textit{str}] \rangle$
  - d. hjælpe ('help', trans):  $\langle \text{NP}[\textit{str}], \text{NP}[\textit{str}] \rangle$

If the personal passive is seen as the promotion of an object that has structural case, the Danish facts and the differences between Danish and the other languages under consideration are explained: Danish has two objects with structural case and hence

both of them can be promoted to subject as in (17b) and (17c). German and English have only one object with structural case, the primary object and hence only the primary object can function as the subject in passives.

The lexical rule in (21) does not account for the passive variants in which a secondary object is promoted to subject. For such a promotion the second object with structural case has to be placed before the first object with structural case in the ARG-ST list. This can be achieved by non-deterministically deleting an NP with structural case from  $\boxed{2}$  in (21) and adding it at the beginning of  $\boxed{2}$ . *delete* and *append* are standard relational constraints and their formulation will not be given here. However, it is possible that  $\boxed{2}$  does not contain any NPs with structural case at all. Passivization then results in impersonal passives. We therefore formulate (25) as the general lexical rule for passives, where *promote* is a relational constraint that identifies its arguments  $\boxed{2}$  and  $\boxed{3}$  if  $\boxed{2}$  does not contain an NP with structural case and otherwise deletes an NP with structural case from  $\boxed{2}$  and appends it at the beginning of  $\boxed{2}$  and returns  $\boxed{3}$ :

(25) Passive lexical rule for Danish, English, and German:

$$\left[ \begin{array}{l} \text{HEAD} \quad \left[ \begin{array}{l} \text{DA} \quad \boxed{1} \\ \textit{verb} \end{array} \right] \\ \text{ARG-ST} \quad \boxed{1} \oplus \boxed{2} \end{array} \right] \mapsto \left[ \text{ARG-ST} \quad \boxed{3} \right] \wedge \textit{promote}(\boxed{2}, \boxed{3})$$

Promote is defined as follows:

$$(26) \quad \textit{promote}(\boxed{2}, \boxed{3}) := \textit{delete}(\boxed{4} \text{ NP}[\textit{str}], \boxed{2}, \boxed{5}) \wedge \\ \textit{append}(\langle \boxed{4} \rangle, \boxed{5}, \boxed{3}). \\ \textit{promote}(\boxed{2}, \boxed{3}) := \boxed{2} = \boxed{3} \text{ otherwise.}$$

In the case of (24c)  $\boxed{2}$  is  $\langle \text{NP}[\textit{str}]_i, \text{NP}[\textit{str}]_j \rangle$ .  $\boxed{4}$  can be either  $\text{NP}_i$  or  $\text{NP}_j$  and  $\boxed{5}$  can be  $\langle \text{NP}_j \rangle$  or  $\langle \text{NP}_i \rangle$ , respectively. The result of appending a list with the deleted element  $\boxed{4}$  with the list  $\boxed{5}$  will be either  $\langle \text{NP}[\textit{str}]_i, \text{NP}[\textit{str}]_j \rangle$  or  $\langle \text{NP}[\textit{str}]_j, \text{NP}[\textit{str}]_i \rangle$ .

## 2.4 Impersonal Passives

As was shown in (22), German has passive participles that have an empty ARG-ST list and participles with an ARG-ST that just contains an NP with lexical dative. Since German does not require a subject, these lexical items can be used in impersonal passive constructions. English does not allow impersonals due to the subject requirement.<sup>5</sup> Danish has a different strategy: It solves the subject problem by inserting an expletive.

<sup>5</sup>As was pointed out in the data section there are passives with an expletive *it* and an extraposed complement clause. Since there is no general ban on sentential subjects in English, these passives seem to be idiosyncratic and a special lexical rule that is a fusion of the passive lexical rule and the *it* extraposition lexical rule by Kim & Sag (2005) seems to be needed.

We assume that Danish differs from German and English in introducing an expletive into the SPR list in the mapping from ARG-ST to SPR and COMPS. German maps all arguments (of finite verbs) to the COMPS list, English and Danish map the first NP/VP/CP to SPR and the remaining arguments to COMPS, and Danish inserts an expletive, if there aren't any elements that could function as subjects. See also Bjerre & Bjerre, 2007, Section 4.3 on expletive insertion in Danish.

So (27) shows the ARG-ST lists for the Danish morphological passives and the participle forms. For *danse* we get an empty ARG-ST list, but due to the mapping constraints we get an NP<sub>expl</sub> in the SPR list of *danset/danses*. (27) shows the respective ARG-ST values and also the SPR and COMPS values:

(27)	ARG-ST	SPR	COMPS
a. danset/danses (unerg):	⟨ ⟩	⟨ NP <sub>expl</sub> ⟩	⟨ ⟩
b. læst/læses (trans):	⟨ NP[ <i>str</i> ] ⟩	⟨ NP[ <i>str</i> ] ⟩	⟨ ⟩
c. givet/gives (ditrans):	⟨ NP[ <i>str</i> ], NP[ <i>str</i> ] ⟩	⟨ NP[ <i>str</i> ] ⟩	⟨ NP[ <i>str</i> ] ⟩
d. hjulpet/hjælpes (trans):	⟨ NP[ <i>str</i> ] ⟩	⟨ NP[ <i>str</i> ] ⟩	⟨ ⟩

## 2.5 The Auxiliary

The lexical item for the passive auxiliary is similar for all three languages: The passive auxiliary is a raising verb:

(28) Passive auxiliary for Danish, German and English:

$$\left[ \text{SYNSEM|LOC|CAT|ARG-ST } \boxed{1} \oplus \boxed{2} \oplus \left\langle \begin{array}{l} \text{VFORM } \textit{PPP} \\ \text{DA} \quad \langle \text{XP}_{ref} \rangle \\ \text{SPR} \quad \boxed{1} \\ \text{COMPS } \boxed{2} \end{array} \right\rangle \right]$$

German forms a predicate complex, that is, a complex consisting of the participle and the passive auxiliary. The arguments of the participle ( $\boxed{1}$  and  $\boxed{2}$ ) are attracted by the passive auxiliary (see Hinrichs & Nakazawa, 1994 on argument attraction). The formation of such predicate complexes is licensed by a special schema, the Head-Cluster Schema that allows non-head daughters to be unsaturated. Danish and English do not allow for complex formation. The respective grammars do not have a Head-Cluster Schema and hence the only way the passive auxiliary can be combined with the participle is via the Head-Complement Schema. Therefore the verbal argument has to have an empty COMPS list, that is,  $\boxed{2}$  in (28) is the empty list for Danish and English. Hence, we have explained how Danish and English embed a VP and German forms a verbal complex although the lexical item of the auxiliary does not require a VP complement.<sup>6</sup>

<sup>6</sup>To rule out VP complements in German, the lexical item for German has to be constrained further: the verbal complement is required to be LEX +.

The specification of the DA value of the participle excludes the embedding of unaccusatives, which have an empty DA value and of weather verbs, which have a non-referential element in the DA list.<sup>7</sup>

## 2.6 The Morphological Passive

We assume that the same lexical rule that accounts for the participle forms can be used for the morphological passives in Danish, modulo differences in the realizations of affixes of course. For the morphological passive it is assumed that the DA of the input to the lexical rule has to contain a referential XP. As was discussed in the previous section, this excludes morphological passives of unaccusatives and weather verbs.

## 2.7 Agent Expressions

We follow Höhle (1978, Chapter 7) and Müller (2003, Section 5) and treat the agent expressions (i.e. the *af/by/von* phrases, respectively) as adjuncts. See Müller, 2013c, Section 17.1.8 for references on this topic and further discussion.

## 2.8 Perfect

The highlight of the analyses for German is that only one participle is needed for both the analysis of the passive and the analysis of the perfect (Haider, 1986). The trick is that the designated argument is blocked but represented in the lexical item of the participle. The passive auxiliary leaves the designated argument blocked, while the perfect auxiliary unblocks it. So, in addition to the passive in (3b) we have the perfect in (29) and both sentences involve the same lexical item for *gelesen* ('read'):

- (29) Er hat den Aufsatz gelesen.  
he has the paper read  
'He read the paper.'

If one wanted to apply the German analysis to Danish and English, one would have to assume a complex predicate analysis like the one depicted in (30a) for Danish and English perfect constructions, since otherwise one would know about the reactivated subject too late and only phrases like *given to Mary* in (30c) would be licensed.

- (30) a. He [has given] the book to Mary.  
b. He has [given the book to Mary].  
c. The book was [given to Mary].

---

<sup>7</sup>The DA feature also plays a role for auxiliary selection (Heinz & Matiassek, 1994, Section 6.6.2). By default all verbs with a designated argument take *haben* ('have') and those without one take *sein* ('to be'). Since weather verbs take *haben* as auxiliary, we assume their DA list to contain their expletive subject.

However, the complex predicate analysis faces several problems for Danish and English. As was shown in Section 1.2, expletives are inserted in Danish impersonal constructions. These expletives are specific for the passive (and presentational constructions) and absent in perfect constructions as (31), that is outside presentational constructions:

- (31) a. at der bliver arbejdet  
           that EXPL is worked  
           ‘that there is working’  
       b. \* at Peter har arbejdet der  
           that Peter has worked EXPL  
       c. \* at der har arbejdet Peter  
           that EXPL has worked Peter

(31b) would be expected if the deblocked element (the NP for *Peter*) were to be appended at the beginning of the ARG-ST list as in the analyses of German and (31c) would be expected if it were to be appended after the expletive. (31b) is grammatical with *der* as a locative adverbial, but not with an expletive. The pattern in (31c) is possible in presentational constructions, but not with definite NPs like Peter. In any case the problem would be that all perfect utterances are predicted to contain an expletive pronoun if this pronoun is part of the valence specification of the participle and if it is inherited by the auxiliary in a complex predicate analysis.

In addition Danish has the so-called *Complex Passive* in which a verb is allowed to govern a participle as part of a passive construction, but not as part of an active construction. (32) illustrates.

- (32) at Bilen blev forsøgt repareret  
       that car.DEF was tried repaired  
       ‘that an attempt was made to repair the car’

The verb *forsøgt* (‘to try’) takes an infinitive in the active and not a participle as in (33b):

- (33) a. at Peter har forsøgt at reparere bilen  
           that Peter has tried to repair car.DEF  
           ‘that Peter tried to repair the car’  
       b. \* at Peter har forsøgt repareret bilen  
           that Peter has tried repaired car.DEF

If one wants to find a solution with just one lexical item for the participle, one needs a way to distinguish participle items that can appear both in the perfect and in the passive from those forms that can appear in the passive only when they select a participle (like the *forsøgt* in (32)). This could be achieved by using a VOICE feature. The value of the VOICE feature would be *passive* for all those lexical items that can appear in the passive only and underspecified for all other participle items. The perfect auxiliary would require the VOICE value to be *perfect*

and hence it would be explained why the respective lexical item for *forsøgt* could not be embedded under *har* ('to have').

The problem with the expletives could be solved by stipulating that the perfect auxiliary attracts arguments from the ARG-ST list rather than from the SPR and COMPS list. Since expletives are not on the ARG-ST list, they would not get in the way.

There is a remaining problem for the complex predicate analysis: VP fronting. VP fronting is possible in German as well and the case assignment in the fronted VP depends on whether the VP is embedded under a passive or a perfect auxiliary. (34) shows examples of partial frontings. (34b) involves VP fronting in a passive sentence and (34c) is an example of VP fronting in an active sentence. As the glosses show, the underlying object is nominative in the passive and accusative in the perfect.

- (34) a. Gelesen wurde der Aufsatz schon oft.  
read was the paper.NOM yet often  
'The paper was read often.'
- b. Der Aufsatz gelesen wurde schon oft.  
the paper.NOM read was yet often  
'The paper was read often.'
- c. Den Aufsatz gelesen hat er schon oft.  
the paper.ACC read has he yet often  
'He read the paper often.'

Meurers (1999) found a way to deal with case assignment into fronted VPs, so this data is not a problem for German. See also Meurers, 2000 and Meurers & De Kuthy, 2001. However, this approach does not extend to English/Danish, since it is not just the case assignment that is different in active and passive sentences but rather the configuration, that is, the position in which objects and subjects are realized: for instance, in (35b) it is clear that *the book* is an object since it is realized in object position, whereas *der Aufsatz/den Aufsatz* in (34b,c) is part of the fronted VP independent of its case/grammatical function.

- (35) a. The book should have been given to Mary and  
[given to Mary] it was.
- b. He wanted to give the book to Mary and  
[given the book to Mary] he has.

*the book* is a member of the COMPS list of *given* in (35b) while the corresponding *it* in (35a) is on the SPR list of *given*. In comparison the NP *der Aufsatz* is a member of the COMPS list of *gelesen* in both (34b) and (34c).

So, unless we find a clever way to underspecify the different mappings to SPR and COMPS, we have to assume two lexical entries for the participle forms in SVO languages like Danish and English.<sup>8</sup>

---

<sup>8</sup>An alternative that assumes just one lexical item and does a remapping of arguments in the syntax is discussed in Section 3.

However, as was discussed above, the analysis of the German passive and perfect can be maintained and is compatible with a more general analysis that also captures the passive in Danish and English.

### 3 Alternatives

There are several different passive analyses in the framework of HPSG by now. Those that were around before 2001 are discussed in Müller, 2002, Section 3.3 and the discussion will not be repeated here. However, there are two interesting new proposals. We will discuss the one by Tseng (2007) about passives in English, which makes fundamental assumptions differing significantly from standard assumptions in lexicalist theories like HPSG. The second approach is by Bjerre & Bjerre (2007) and deals explicitly with Danish. This proposal differs from previous proposals by including a representation of semantic facts that are relevant for the passive in Danish. Due to space limitations we will not discuss this proposal here but refer the reader to Müller & Ørsnes (In Preparation). We now turn to Tseng's suggestion.

While passive is usually analyzed as a lexical operation in the framework of HPSG, Tseng (2007, Section 3.1) suggests an analysis in which the valence information is reorganized in syntax. For the personal passive in English he suggests the schema in Figure 1. This construction takes a word or phrase that selects for

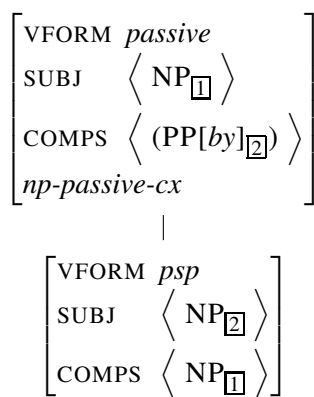

Figure 1: Schema for passive according to Tseng (2007)

a subject and an object and changes the valence properties of the word or phrase in such a way that the new subject is linked to the former object and a *by*-PP is selected as a complement that is coindexed with the subject of the dominated word or phrase. The schema would apply to the word *read* in (36a) and to the phrase *given the ball* in (36b).

- (36) a. The book was read by Mary.  
 b. The boy was given the ball.



Tseng provides two further schemata to deal with prepositional passives: one for complement prepositions and one for adjunct prepositions.

There are two major problems with his proposal: first, the status of intermediate phrases is unclear, and second the interaction of the argument structure change in the passive and derivational morphology cannot be explained. We will discuss these points in the following subsections.

### 3.1 The Status of Intermediate Phrases

In order for the passive schema to be applicable, it must be possible to derive a phrase *given the ball* with a verb that selects two complements as in (37):

(37) He has given the boy the ball.

The analysis of (36b) is shown in Figure 2: The phrase *given the ball* is formed and

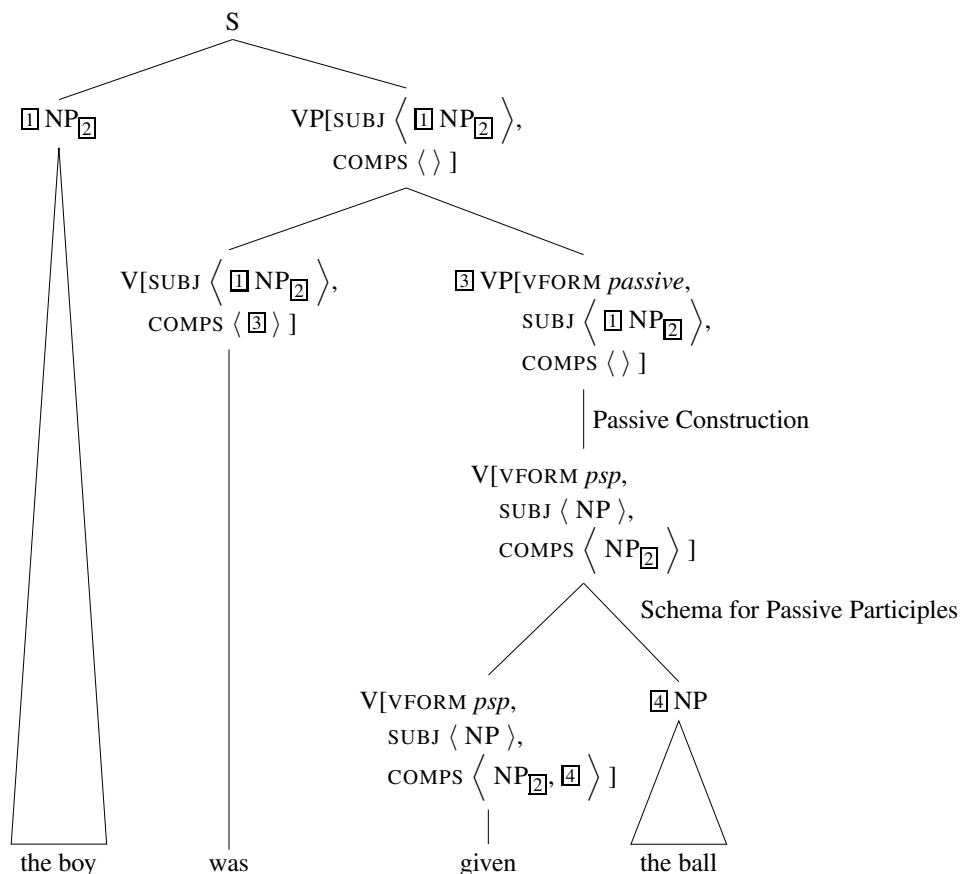

Figure 2: Analysis of *The boy was given the ball* according to Tseng (2007)

then the remaining object (NP<sub>2</sub>) is mapped to subject by the NP Passive Construction. The auxiliary combines with the licensed passive VP. The subject is raised by

the auxiliary and then combined with the VP *was given the ball*.

The problem now is that the phrase *given the ball* is usually not licensed by any grammar for English. Pollard & Sag (1994) and most subsequent work assume flat structures in which a  $V^0$  is combined with all its complements and even if one assumes binary branching structures as we do, *given the ball* would never be licensed as a constituent. So in order to license this constituent one would need a separate schema that basically combines an active item with its arguments as if it were a passive item. This schema would behave like a combination of our passive lexical rule (argument reducing) plus the normal combinatory schemata. To see this compare Figure 2 with Figure 3. The Passive Lexical Rule applies to

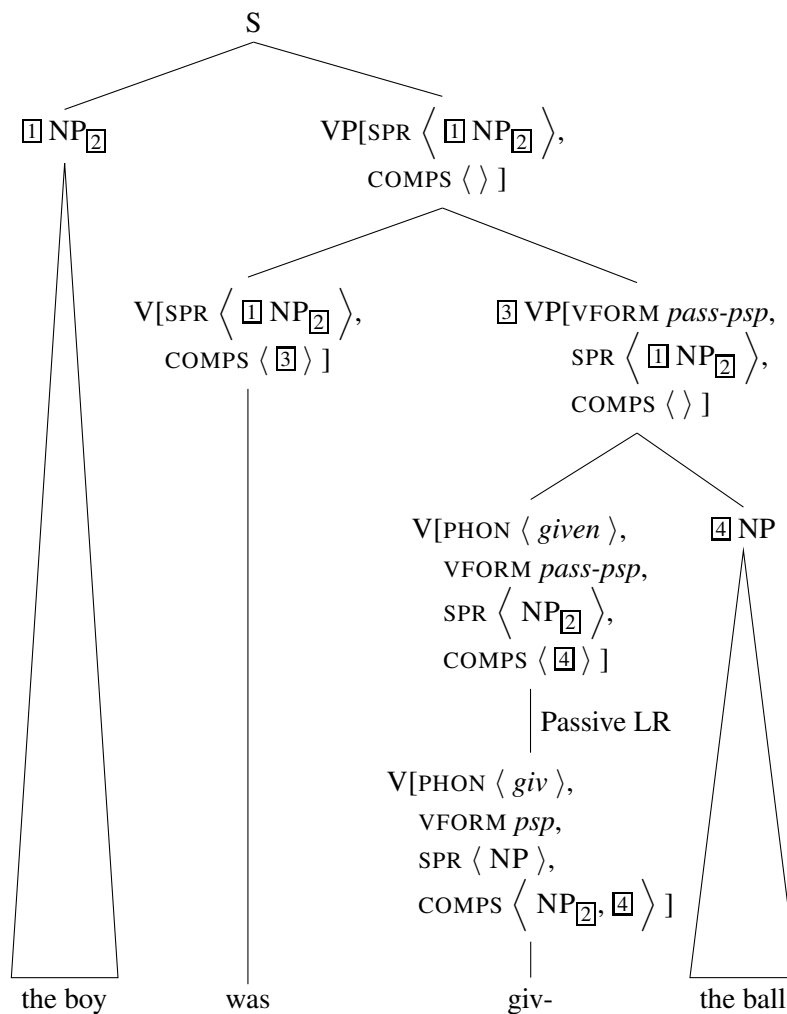

Figure 3: Lexical analysis of *The boy was given the ball*

the verbal stem *giv-* and adds the inflectional affix. The subject is suppressed and the former object being the first element on the ARG-ST list of the licensed sign

is mapped to SPR. The lexical item for *given* is combined with the object via the usual head complement schema and the rest of the analysis is parallel to Tseng's analysis that was discussed above.

To sum up: Since Tseng's analysis requires special mechanisms to license partial constituents that are not needed anywhere else, the analysis is more complex than the lexical one.

### 3.2 Interaction with Derivational Morphology

A very old argument for a lexical analysis of the passive was provided by Dowty (1978, p. 412) and Bresnan (1982, p. 21). It is a classical level ordering argument. If certain processes are known or assumed to apply at a certain level and it can be shown that another process feeds such processes, then the latter process has to be ordered before the others. Bresnan and Dowty noted that passive participles can also be used prenominally:

- (38) a. The toy is being broken (by the child).  
b. the broken toy

That these forms are adjectives, not verbs, is shown by a host of properties, including negative *un-* prefixation: *unbroken* means 'not broken', just as *unkind* means 'not kind', while the *un-* appearing on verbs indicates, not negation, but action reversal, as in *untie* (Bresnan, 1982, p. 21). The situation is even clearer in languages with adjectival inflection: for instance in German, prenominal adjectives are inflected and prenominal participles inflect like adjectives rather than verbs.

Predicate adjectives preserve the subject of predication of the verb and for prenominal adjectives the rule is simply that the role that would be assigned to the subject goes to the modified noun instead (*The toy remained (un-)broken.; the broken toy*).

In the phrasal account the passive variant of *broken* would be formed in syntax and would not be available for the morphological process of *un-* prefixation. See also Müller, 2006 and Müller & Wechsler, 2014 for discussion of problems with derivational morphology that result for phrasal analyses of valence changing processes.

So, concluding the discussion, it must be said that the constructional analysis has no account of the morphological data, it cannot account for sentential subjects in passive constructions without duplicating or considerably complicating the schemata and it needs additional schemata to license constituents that are usually not assumed in grammars of English. Hence, lexical analyses along the lines described here are formally simpler and empirically more adequate than phrasal analyses of the kind discussed above.

## 4 Further Research

A reviewer pointed us to a possible problem for our assumption that passivization of ditransitive verbs involves permutation of the two objects on the ARG-ST list. In Norwegian the binding properties of reflexives are the same as in the active no matter what object is promoted so subject. This is unexpected if binding is defined over the ARG-ST list. In that case passive must be handled in the mapping from ARG-ST to the valence features. However, Lars Hellan (p. c. 2013) argues that the data in Hellan, 1988, p. 162 cannot be accounted for with respect to the ARG-ST list at all. Therefore Hellan (2005) developed an account for pronoun binding that does not rely on ARG-ST prominence.

There have been proposals by Manning & Sag (1998) for a more elaborate representation of the ARG-ST list. In Manning and Sag's analysis the ARG-ST list contains sublists and PRO elements that are not realized as arguments at the surface.

We do not take a stand on whether mechanisms like the one suggested by Hellan or complex representations in the ARG-ST list are the way to go. We noted in Müller, 1999, Chapter 20 that the Binding Theory of Pollard & Sag (1994) could not be applied to German data successfully and hence put binding data aside.

Another point that needs further work is the order of elements in the ARG-ST list. We deviated from earlier work by assuming the order nom, dat, acc for German and the corresponding orders for Danish and English, that is, agent, recipient, theme/transferred object. While this order corresponds to the surface order of arguments in Danish and English and to the unmarked order in German other areas of grammar seem to suggest a different ordering. For instance, datives seem to be more oblique as far as the formation of non-matching free relatives are concerned, they do not participate in topic drop structures as easily, datives are dispreferred as antecedents of depictive predicates (Müller, 2008) and so on. On the other hand Kiss (2001) argued that the order nom, dat, acc is relevant for scope determination. So, it may be the case that two different orderings have to be reflected in grammars of natural languages.

## 5 Conclusion

We have provided an account of the Danish, English and German passive that assumes that both morphological and analytical passives are analyzed with a lexical rule suppressing the first argument on the ARG-ST list of the input lexical item. Danish differs from German and English by inserting an expletive into the SPR list if there is no other element that could fill the subject position. German differs from both Danish and English in having a lexical dative as object of verbs like *helfen* ('to help'), which results in an impersonal passive as compared to the personal passive in Danish and English. The possibility to promote both the primary and the secondary object in Danish is accounted for by an analysis that allows all objects with

structural case to be promoted to subject. The respective passives in German and English are ruled out by the assumption that the case of the secondary objects in these languages is lexical.

The analyses have been implemented in the TRALE system (Meurers, Penn & Richter, 2002; Penn, 2004; Müller, 2007) as part of grammar fragments of German (Müller, 2013c), Danish (Müller & Ørsnes, In Preparation), and English. These grammars are developed in the CoreGram project<sup>9</sup> (Müller, 2013a,b) and share a core grammar with grammars for Persian, Mandarin Chinese, Maltese, and Yiddish.

## 6 Acknowledgments

We thank the reviewers of the HPSG conference for helpful comments and Emily M. Bender, Lars Hellan and the participants of the conference for discussion. We thank Frank Van Eynde for comments on an earlier version of this paper and Philippa Cook for discussion and proofreading.

## References

- Bjerre, Anne & Tavs Bjerre. 2007. Perfect and periphrastic passive constructions in Danish. *Nordic Journal of Linguistics* 30(1). 5–53.
- Bresnan, Joan. 1982. The passive in lexical theory. In Joan Bresnan (ed.), *The mental representation of grammatical relations*, 3–86. Cambridge, MA/London: MIT Press.
- Dalrymple, Mary & Helge Lødrup. 2000. The grammatical functions of complement clauses. In Miriam Butt & Tracy Holloway King (eds.), *Proceedings of the LFG 2000 conference*, Stanford: CSLI Publications.
- Dowty, David R. 1978. Governed transformations as lexical rules in a Montague Grammar. *Linguistic Inquiry* 9(3). 393–426.
- Engdahl, Elisabet. 2001. Scandinavian passives in hpsg. In Arthur J. Holmer, Jan-Olof Svantesson & Åke Viberg (eds.), *Proceedings of the 18th scandinavian conference of linguistics*, 23–36. Lund: Department of Linguistics.
- Haider, Hubert. 1986. Fehlende Argumente: vom Passiv zu kohärenten Infinitiven. *Linguistische Berichte* 101. 3–33.
- Heinz, Wolfgang & Johannes Matiasek. 1994. Argument structure and case assignment in German. In Nerbonne et al. (1994) 199–236.
- Hellan, Lars. 1988. *Anaphora in Norwegian and the theory of grammar*. Berlin: Walter de Gruyter.
- Hellan, Lars. 2005. Implementing Norwegian reflexives in an HPSG grammar. In Müller (2005) 519–539.

---

<sup>9</sup><http://hpsg.fu-berlin.de/Projects/CoreGram.html>

- Hinrichs, Erhard W. & Tsuneko Nakazawa. 1994. Linearizing AUXs in German verbal complexes. In Nerbonne et al. (1994) 11–38.
- Höhle, Tilman N. 1978. *Lexikalische Syntax: Die Aktiv-Passiv-Relation und andere Infinitkonstruktionen im Deutschen*. Tübingen: Niemeyer.
- Kim, Jong-Bok & Ivan A. Sag. 2005. English object extraposition: A constraint-based approach. In Müller (2005) 192–212.
- Kiss, Tibor. 2001. Configurational and relational scope determination in German. In Walt Detmar Meurers & Tibor Kiss (eds.), *Constraint-based approaches to Germanic syntax*, 141–175. Stanford: CSLI Publications.
- Manning, Christopher D. & Ivan A. Sag. 1998. Argument structure, valance, and binding. *Nordic Journal of Linguistics* 21(2). 107–144.
- Meurers, Detmar. 1999. Raising spirits (and assigning them case). *Groninger Arbeiten zur Germanistischen Linguistik (GAGL)* 43. 173–226.
- Meurers, Detmar. 2000. Lexical generalizations in the syntax of German non-finite constructions. Arbeitspapiere des SFB 340 No. 145 Universität Tübingen.
- Meurers, Detmar & Kordula De Kuthy. 2001. Case assignment in partially fronted constituents. In Christian Rohrer, Antje Roßdeutscher & Hans Kamp (eds.), *Linguistic form and its computation*, 29–63. Stanford: CSLI Publications.
- Meurers, Detmar, Gerald Penn & Frank Richter. 2002. A web-based instructional platform for constraint-based grammar formalisms and parsing. In Dragomir Radev & Chris Brew (eds.), *Effective tools and methodologies for teaching NLP and CL*, 18–25.
- Müller, Stefan. 1999. *Deutsche Syntax deklarativ. Head-Driven Phrase Structure Grammar für das Deutsche*. Tübingen: Niemeyer.
- Müller, Stefan. 2002. *Complex predicates: Verbal complexes, resultative constructions, and particle verbs in German*. Stanford: CSLI Publications.
- Müller, Stefan. 2003. Object-to-subject-raising and lexical rule. an analysis of the German passive. In Stefan Müller (ed.), *Proceedings of the 10th international conference on Head-Driven Phrase Structure Grammar, michigan state university, east lansing*, vol. 4, 278–297. Stanford: CSLI Publications.
- Müller, Stefan (ed.). 2005. *Proceedings of the 12th international conference on Head-Driven Phrase Structure Grammar, department of informatics, university of lisbon*. Stanford: CSLI Publications.
- Müller, Stefan. 2006. Phrasal or lexical constructions? *Language* 82(4). 850–883.
- Müller, Stefan. 2007. The Grammix CD Rom. a software collection for developing typed feature structure grammars. In Tracy Holloway King & Emily M. Bender (eds.), *Grammar engineering across frameworks 2007*, Stanford: CSLI Publications.
- Müller, Stefan. 2008. Depictive secondary predicates in German and English. In Christoph Schroeder, Gerd Hentschel & Winfried Boeder (eds.), *Secondary predicates in Eastern European languages and beyond*, 255–273. Oldenburg: BIS-Verlag.
- Müller, Stefan. 2013a. The CoreGram project: A brief overview and motivation. In Denys Duchier & Yannick Parmentier (eds.), *Proceedings of the workshop on*

- high-level methodologies for grammar engineering (HMGE 2013)*, Düsseldorf, 93–104.
- Müller, Stefan. 2013b. The CoreGram project: Theoretical linguistics, theory development and verification. Ms. Freie Universität Berlin. <http://hpsg.fu-berlin.de/~stefan/Pub/coregram.html>.
- Müller, Stefan. 2013c. *Head-Driven Phrase Structure Grammar: Eine Einführung*. Tübingen: Stauffenburg Verlag 3rd edn.
- Müller, Stefan. To appear. HPSG – a synopsis. In Artemis Alexiadou & Tibor Kiss (eds.), *Syntax – Ein internationales Handbuch zeitgenössischer Forschung*, Berlin: Walter de Gruyter 2nd edn.
- Müller, Stefan & Bjarne Ørnes. 2011. Positional expletives in Danish, German, and Yiddish. In Stefan Müller (ed.), *Proceedings of the 18th international conference on Head-Driven Phrase Structure Grammar, University of Washington, U.S.A.*, 167–187. Stanford: CSLI Publications.
- Müller, Stefan & Bjarne Ørnes. In Preparation. *Danish in Head-Driven Phrase Structure Grammar*. Berlin: Language Science Press.
- Müller, Stefan & Stephen Mark Wechsler. 2014. Lexical approaches to argument structure. *Theoretical Linguistics* 40(1–2). In Print.
- Nerbonne, John, Klaus Netter & Carl J. Pollard (eds.). 1994. *German in Head-Driven Phrase Structure Grammar*. Stanford: CSLI Publications.
- Penn, Gerald. 2004. Balancing clarity and efficiency in typed feature logic through delaying. In Donia Scott (ed.), *Proceedings of the 42nd meeting of the association for computational linguistics (acl'04), main volume*, 239–246. Barcelona, Spain.
- Pollard, Carl J. 1996. On head non-movement. In Harry Bunt & Arthur van Horck (eds.), *Discontinuous constituency*, 279–305. Berlin, New York: Mouton de Gruyter.
- Pollard, Carl J. & Ivan A. Sag. 1992. Anaphors in English and the scope of binding theory. *Linguistic Inquiry* 23(2). 261–303.
- Pollard, Carl J. & Ivan A. Sag. 1994. *Head-Driven Phrase Structure Grammar*. Chicago, IL and London: University of Chicago Press.
- Przepiórkowski, Adam. 1999. *Case assignment and the complement-adjunct dichotomy: A non-configurational constraint-based approach*: Universität Tübingen dissertation.
- Tseng, Jesse L. 2007. English prepositional passive constructions. In Stefan Müller (ed.), *Proceedings of the 14th international conference on Head-Driven Phrase Structure Grammar*, 271–286. Stanford: CSLI Publications.

# The syntax of distance distributivity in Polish: Preserving generalisations with weak heads

Adam Przepiórkowski 

Institute of Computer Science, Polish Academy of Sciences

Proceedings of the 20th International Conference on  
Head-Driven Phrase Structure Grammar

Freie Universität Berlin

Stefan Müller (Editor)

2013

Stanford, CA: CSLI Publications

pages 161–181

Przepiórkowski, Adam. 2013. The syntax of distance distributivity in Polish: Preserving generalisations with weak heads. In Stefan Müller (ed.), *Proceedings of the 20th International Conference on Head-Driven Phrase Structure Grammar, Freie Universität Berlin*, 161–181. Stanford, CA: CSLI Publications. DOI: 10.21248/hpsg.2013.9. 



## Abstract

This paper presents a syntactic HPSG analysis of distance distributivity in Polish, where the challenge is to uniformly analyse a number of function lexemes PO ‘each’ which share their form and semantic contribution, but differ in their syntactic behaviour. To this end, the HPSG notion of *weak head* is employed in a novel way.

## 1 Introduction

The empirical aim of this paper is to discuss a phenomenon in Polish which is somewhat similar to the behaviour of English EACH, as in: *I gave the boys two apples each.*<sup>1</sup> The phenomenon where the so-called binominal EACH (Safir & Stowell, 1988) attaches to the noun phrase (NP) denoting the distributed quantity (*two apples*) and looks elsewhere in the sentence for the set to distribute over (*the boys*) is called *distance distributivity* (Zimmermann, 2002). As we will see below, distance distributivity in Polish involves not one but a number of simultaneously homophonous and homosemous<sup>2</sup> elements which differ in their syntactic behaviour.

The theoretical goal is to provide an HPSG analysis of Polish distance distributivity that does not miss generalisations, i.e., one that relates the form *po* to the distributive semantics only once in the grammar, even though there are a few distinct lexical items sharing this form and meaning. To this end we – rather trivially – factor out constraints common to all relevant lexical entries within the Word Principle. For this to be possible, we also – perhaps less trivially – employ the notion of *weak head* (Tseng, 2002; Abeillé, 2003, 2006) in order to ensure the uniform headedness status of words described by these lexical entries.

There are two main sections corresponding to the two aims mentioned above: section 2 introduces the phenomenon in gory detail and section 3 proposes the HPSG analysis. This paper is strongly coupled with Przepiórkowski & Patejuk 2013, which presents an LFG account of the same facts; correspondingly, the empirical section 2 is shared between these two papers almost verbatim (with apologies to readers). Moreover, Przepiórkowski 2013 provides the semantic half of the complete syntactico-semantic analysis of distributivity in Polish, couched in Glue Semantics (Dalrymple, 1999, 2001).

---

<sup>1</sup>A note on some conventions used in this paper: in the running text, lexemes are typeset in SMALL CAPITALS and word forms and example sentences – in *italics*. Numbered examples, as in (1)–(2) below, are typeset in ordinary upright font, with grammatical information in SMALL CAPITALS. Grammatical abbreviations mostly adhere to those recommended in Leipzig Glossing Rules (<http://www.eva.mpg.de/lingua/resources/glossing-rules.php>).

<sup>2</sup>We use the term *homosemous* as in Harley 2006, pp. 146ff., i.e., to refer to function (as opposed to content) morphemes or words which are not necessarily interchangeable in a given context but have the same meaning.

## 2 Distance distributivity in Polish

### 2.1 Preliminaries

The most basic use of the distributive PO is illustrated below:

- (1) Dałem im po jabłku.  
gave-I them.DAT DISTR apple.LOC  
'I gave them an apple each.'
- (2) Dałem im po dwa jabłka.  
gave-I them.DAT DISTR two.ACC apples.ACC  
'I gave them two apples each.'

These examples already illustrate one curious fact about PO: it may combine with the locative case (cf. (1)), reserved to arguments of prepositions in Polish, or with the accusative (cf. (2)). So at least some uses of PO must be treated as prepositional, as otherwise the overwhelming generalisation that in Polish locative only occurs on arguments of prepositions would be violated.

The first article-length treatment of the distributive PO in Polish linguistics is Łojasiewicz 1979.<sup>3</sup> That paper suggests that the case of the phrase cooccurring with PO depends on the type of this phrase (NP in (1) and numeral phrase, or NumP, in (2); cf. Łojasiewicz 1979, p. 155), rather than on its grammatical number (singular in (1), plural in (2)). The matter should be easy to decide by considering plural noun phrases or singular numeral phrases. Unfortunately, the latter arguably do not exist in Polish; Przepiórkowski 2006b claims that all Polish numerals are plural, even those meaning 'a half' (Pol. PÓŁ) or 'a quarter' (Pol. CWIERCĆ). Moreover, there seems to be a semantic restriction at work (cf. Łojasiewicz 1979; Przepiórkowski 2008; Bogusławski 2012) which prohibits locative NP arguments of PO from denoting aggregate entities of unspecified cardinality, as in:

- (3) \*Dałem im po jabłkach.  
gave-I them.DAT DISTR apples.LOC  
'I gave them some apples each.' (intended)

Nevertheless, the issue may be resolved by considering plural NPs denoting non-aggregate entities, i.e., *plurale tantum* nouns such as SPODNIE 'trousers', PERFUMY 'perfumes', etc. As shown in Przepiórkowski 2006a, and contra Łojasiewicz 1979, such NPs may co-occur with the distributive PO and, when they do, they bear the locative case. This shows that the locative is indeed conditioned by the categorial status of the noun phrase and not by its singular grammatical number. Hence, from now on, we will refer to PO in (1) (and similar contexts) as *adnominal*, PO<sub>N</sub>, and to PO in (2) (and such) as *adnumeral*, PO<sub>NUM</sub>.

<sup>3</sup>See also Franks 1995, §5.2.1, for a generative account and comparison with the distributive PO in other Slavic languages.

Łojasiewicz 1979, p. 154, also notes that the distribution of the distributive PO is limited to the accusative (as in (1)–(2) above), nominative and “secondary genitive” positions. What is meant by a “secondary genitive” position is a genitive dependent of a negated (cf. (5))<sup>4</sup> or nominalised (cf. (6)) verb (i.e., a gerundial form) corresponding to the accusative dependent of the affirmative verb form (cf. (4)):

- (4) Dałem im jabłko.  
gave-I them.DAT apple.ACC  
‘I gave them an apple.’
- (5) Nie dałem im jabłka / \*jabłko.  
NEG gave-I them.DAT apple.GEN/\*ACC  
‘I didn’t give them an apple.’
- (6) Myśleliśmy o daniu im jabłka / \*jabłko.  
thought-we about giving them.DAT apple.GEN/\*ACC  
‘We were thinking about giving them an apple.’

For the adnominal PO<sub>N</sub>, Łojasiewicz 1979 gives the following example of its occurrence in the otherwise nominative (subject) position:

- (7) Z drzew spadło po jabłku.  
from trees fell.3.N.SG DISTR apple.LOC  
‘An apple fell from each tree.’

To this, the following examples of PO<sub>N</sub> in “secondary genitive” positions could be adduced, parallel to (5)–(6) above:

- (8) Nie dałem im po jabłku.  
NEG gave-I them.DAT DISTR apple.LOC  
‘I didn’t give them an apple each.’
- (9) Myśleliśmy o daniu im po jabłku.  
thought-we about giving them.DAT DISTR apple.LOC  
‘We were thinking about giving them an apple each.’

On the other hand, PO<sub>N</sub> cannot occur in other case positions, including dative, instrumental and “primary genitive”. This is illustrated in (10a)–(12a), involving verbs subcategorising for dative, instrumental and genitive complements, respectively, contrasted with (10b)–(12b) involving roughly synonymous verbs subcategorising for accusative complements:<sup>5,6,7</sup>

<sup>4</sup>Genitive of negation in Polish, while more regular than in Russian, is more complex than would transpire from the remarks in this paper; see Przepiórkowski 2000.

<sup>5</sup>RM stands here for *reflexive marker*, a part of the inherently reflexive verbs PRZYGLĄDAĆ SIĘ ‘observe’ and CHWYCIĆ SIĘ ‘grab’.

<sup>6</sup>Note that the forms of JEDEN ‘one’ in these examples are not numerals, but rather adjectives, pace Saloni 1974 and Gruszczyński & Saloni 1978; see also Przepiórkowski 2006a for the reaffirmation of this position based on the cooccurrence of PO and JEDEN.

<sup>7</sup>(11a) sounds acceptable to one of the authors.

- (10) a. \*Każdy z nich przyglądał się po (jednym) obrazie.  
 each.NOM of them watched RM DISTR one.LOC painting.LOC  
 ‘Each of them watched a/one painting.’ (intended)
- b. Każdy z nich oglądał po (jednym) obrazie.  
 each.NOM of them watched DISTR one.LOC painting.LOC  
 ‘Each of them watched a/one painting.’
- (11) a. \*Każdy z nich kierował po (jednej) firmie.  
 each.NOM of them ran DISTR one.LOC company.LOC  
 ‘Each of them directed a/one company.’ (intended)
- b. Każdy z nich nadzorował po (jednej) firmie.  
 each.NOM of them supervised DISTR one.LOC company.LOC  
 ‘Each of them supervised a/one company.’
- (12) a. \*Każdy z nich chwycił się po (jednej) linie.  
 each.NOM of them grabbed RM DISTR one.LOC rope.LOC  
 ‘Each of them grabbed a/one rope.’ (intended)
- b. Każdy z nich chwycił po (jednej) linie.  
 each.NOM of them grabbed DISTR one.LOC rope.LOC  
 ‘Each of them grabbed a/one rope.’

At first glance facts seem to be similar for the adnumeral  $PO_{NUM}$ . Its occurrence in an accusative position is illustrated in (2) above, and the following examples, all from Łojasiewicz 1979, illustrate a (normally, see below) nominative position (cf. (13)), a genitive of negation position (cf. (14)) and an ad-gerundial genitive position (cf. (15)):

- (13) Na moich drzewach dojrzewa dziennie po kilka owoców.  
 on my trees ripen.3.SG daily DISTR several.ACC fruit.GEN  
 ‘Several pieces of fruit ripen every day on each of my trees.’
- (14) Dzieci nie dostały po dwa pączki.  
 children.NOM NEG received.3.PL DISTR two.ACC donuts.ACC  
 ‘The children did not get two donuts each.’
- (15) Myśleliśmy o daniu dzieciom po trzy pączki.  
 thought-we about giving children.DAT DISTR three.ACC donuts.ACC  
 ‘We thought about giving the children three donuts each.’

It should be noted that, while the accusative case of *dwa jabłka* ‘two apples’ in (2) could in principle reflect the fact that the  $PO_{NUM}$ -phrase occupies an accusative position ( $PO_{NUM}$  would be transparent to case assignment on such an analysis), examples (14)–(15), where such  $PO_{NUM}$ -phrases occur in genitive positions, show that  $PO_{NUM}$  does (or at least *may*, see below) assign the accusative case, i.e., that it does (or may) behave like a preposition.

All these considerations lead to the conclusion that there must be (at least) two different distributive elements PO: one assigning the locative to NPs, and another assigning the accusative to NumPs. In fact, Łojasiewicz 1979, p. 158, discusses the possibility of a single distributive PO assigning a separate case, *distributivus*, which would always be syncretic with locative or accusative, depending on the grammatical class.<sup>8</sup> She rejects this idea, though, on the basis of the apparent impossibility of such NP and NumP *distributivus* phrases to be coordinated into a single argument of PO and claims that the following example should only mean *You'll get one apple each, as well as two pears and five plums*, and not – as intended – *Each of you will get one apple, two pears and five plums*:

- (16) Dostaniecie po jednym jabłku, dwie gruszki i  
 receive-you.FUT DISTR one.LOC apple.LOC two.ACC pears.ACC and  
 pięć śliwek.  
 five.ACC plums.GEN  
 ‘Each of you will get one apple, two pears and five plums.’ (*intended*)  
 ‘You will get one apple each, as well as two pears and five plums.’ (*actual*)

While remaining agnostic about such examples, we concur with Łojasiewicz 1979 that PO<sub>N</sub> and PO<sub>NUM</sub> should not be conflated into a single lexeme. In the remainder of this empirical section we will have nothing more to say about the adnominal PO<sub>N</sub> and will concentrate on PO<sub>NUM</sub>.

## 2.2 Three distributive elements PO

### 2.2.1 Adnumeral PO in subject positions

As in other Indo-European languages, also in Polish finite verbs agree with nominative subjects, and otherwise occur in the default third person singular neuter form (Dziwirek, 1990). This generalisation is upheld in (7) and (13) above, where the subjects headed by PO<sub>N</sub> and PO<sub>NUM</sub>, respectively, are prepositional phrases and, hence, apparently caseless (but see §3 below). From this perspective, the following examples from Łojasiewicz 1979, p. 154, are surprising:<sup>9</sup>

- (17) W pokojach będą po dwa fotele.  
 in rooms be.FUT.PL DISTR two.NOM.PL armchair.NOM.PL  
 ‘There will be two armchairs in each room.’
- (18) Na ławkach leżały po trzy arkusze papieru.  
 on benches lay.PL PO three.NOM.PL sheet.NOM.PL paper.GEN.SG  
 ‘There lay three sheets of paper on each bench.’

<sup>8</sup>She also considers the two fossilised expressions *po czemu* ‘how much each’ and *po złotemu* ‘one zloty each’, where *czemu* and *złotemu* are dative forms.

<sup>9</sup>Case values indicated in glosses reflect the received wisdom. In the analysis presented below we will claim that the numeral (*dwa, trzy*) and the noun heading the following NP (*fotele, arkusze*) are in the accusative, and that PO is the sole bearer of the nominative case; see §2.3.

Here, the verb clearly agrees with the numeral phrase following  $PO_{NUM}$ . Łojasiewicz 1979 does not draw the obvious conclusion from these examples, but if the overwhelming generalisation concerning subject–verb agreement in Polish is to be maintained, (17)–(18) must be analysed as involving nominative subjects. In particular, such subjects cannot be run-of-the-mill prepositional phrases.

The issue is somewhat obfuscated by the fact that numeral phrases following  $PO_{NUM}$  in all examples above are syncretic between nominative and accusative, at least in the sense that they may occur in subject positions and in (accusative) direct object positions.<sup>10</sup> So perhaps all numeral phrases occurring after  $PO_{NUM}$  should be analysed as nominative, rather than accusative?

Fortunately, there exist non-syncretic nominative forms of the paucal numerals DWA ‘two’, TRZY ‘three’ and CZTERY ‘four’, namely, the human-masculine forms *dwaj*, *trzej* and *czterej*, as in the following example:

- (19) Radę           tworzyli       dwaj       przedstawiciele       regionu.  
       council.ACC constituted.PL two.NOM representatives.NOM region.GEN  
       ‘Two region representatives constituted the council.’

Crucially, such nominative forms cannot occur after  $PO_{NUM}$  in accusative or “secondary genitive” positions, which confirms the analysis of  $PO_{NUM}$  as governing the accusative – not nominative – case there:

- (20) (Nie) przydzieliłem im       po       dwóch       przedstawicieli.  
       NEG assigned-I    them.DAT DISTR two.ACC representatives.ACC/GEN  
       ‘I (did not) assign(ed) them two representatives each.’

- (21) \*(Nie) przydzieliłem im       po       dwaj       przedstawiciele.  
       NEG assigned-I    them.DAT DISTR two.NOM representatives.NOM

On the other hand, phrases headed by such unambiguously nominative paucal numerals may co-occur with  $PO_{NUM}$  in the subject position, duly resulting in subject–verb agreement; although in some publications they are regarded marginal (Łojasiewicz, 1979, p. 158), doubtful or even downright unacceptable (Derwojedowa, 2011, pp. 144–145), they do occur in texts, as in the following attested examples:<sup>11</sup>

<sup>10</sup>See Przepiórkowski 1999, 2004 for arguments that non-paucal numerals (as well as some human-masculine paucal numerals) in the subject position are in fact accusative; e.g., (13) without the *po* would still be grammatical and the subject *kilka owoców* would be analysed as accusative. On the other hand, (non-human-masculine) paucal numeral forms like *dwa* ‘two’ and *trzy* ‘three’ in (17)–(18), would be analysed as nominative. The observation that some numeral phrases in the subject position occur in the accusative has a long history, dating back at least to Małecki 1863 and Krasnowolski 1897, and – more recently – Franks 1995, but it is also very controversial in Polish linguistics; see, e.g., Saloni 2005 and Miechowicz-Mathiasen & Witkoś 2007 for discussion, and Przepiórkowski & Patejuk 2012a,b for an LFG analysis.

<sup>11</sup>The first example comes from the National Corpus of Polish (NKJP; Przepiórkowski et al. 2012; <http://nkjp.pl>), the other two were found in the Internet via Google (September 2013).

- (22) Prezydent proponuje, aby Radę Federacji tworzyli po  
 president proposes that council.ACC federation.GEN constitute.PL DISTR  
 dwaj przedstawiciele każdego regionu...  
 two.NOM representatives.NOM each.GEN region.GEN  
 ‘The President proposes that two representatives of each region constitute  
 the Federation Council.’ (NKJP)
- (23) Do Senatu wybierani są po dwaj senatorzy z każdego  
 to Senate elected.PL are.PL DISTR two.NOM senators.NOM from each  
 stanu.  
 state  
 ‘Two senators from each state are elected to the Senate.’ (Google)
- (24) ... awans uzyskali po trzech najlepsi z każdej  
 promotion obtained.PL DISTR three.NOM best.NOM.PL from each  
 kategorii.  
 category  
 ‘Three best ones from each category qualified.’ (Google)

Also Łojasiewicz 1979, p. 158, admits forms such as *dwaj* “in some constructions” involving the distributive PO, citing as grammatical the following example:

- (25) Stańcie tu, po dwaj z każdej strony.  
 stand.IMP.PL here DISTR two.NOM from each side  
 ‘Stand here, two on each side!’

In summary, the data discussed in this subsection calls for distinguishing two adnumeral elements  $PO_{NUM}$ : one, which we will call  $PO_{NUM}^{ACC}$ , assigns the accusative case, even in the “secondary genitive” positions, and another one,  $PO_{NUM}^{MOD}$ , which may occur with nominative numeral phrases. The relative distribution of these two distributive adnumeral elements will be discussed in §2.3, but first we provide additional arguments for the existence of a separate  $PO_{NUM}^{MOD}$  and some justification for the superscript MOD (for *modifier*).

## 2.2.2 Adnumeral PO in other positions

As apparently first noted in Przepiórkowski 2010,  $PO_{NUM}$  sometimes occurs also in dative positions. When it does, the numeral phrase must also bear the dative case. The following attested examples illustrate this:

- (26) ... nagroda należy się po trzech osobom z każdej klasy...  
 reward is due to DISTR three.DAT person.DAT.PL from each class  
 ‘Three people from each class deserve a reward.’ (NKJP)

(27) Broń... została przekazana po dwóm osobom z  
 weapon AUX transferred.PASS DISTR two.DAT person.DAT.PL from  
 każdego ugrupowania.  
 each group  
 ‘The weapon was handed in to two people from each group.’ (Google)

(28) ...cyklicznie dawał odpoczywać po dwóm zawodnikom...  
 cyclically let.SG rest DISTR two.DAT players.DAT  
 ‘He cyclically let two players take rest.’ (Google)

While perhaps less frequent, analogous examples may be found involving instrumental positions,<sup>12</sup> cf. (29)–(31), and even an occasional genitive or locative position, cf. (32) and (33), respectively.

(29) Obie strony dysponują w końcu po czterema armiami.  
 both sides have at their disposal in the end DISTR four.INST armies.INST  
 ‘Both sides have at their disposal four armies each in the end.’ (Google)

(30) Każde z nich w białym kitlu, dużych okularach, z po dwiema  
 each of them in white lab coat big glasses with DISTR two.INST  
 teczkami – w jednej są narzędzia, w drugiej dokumentacja.  
 briefcases.INST in one are tools in second documentation  
 ‘Each of them in a white lab coat, big glasses, with two briefcases each –  
 tools are in the first one, documentation in the other.’ (Google)

(31) Jego... uszy są... ozdobione po trzema złotymi kolczykami u  
 his ears are ornamented DISTR three.INST gold.INST earrings.INST at  
 dołu małżowiny.  
 bottom auricle  
 ‘His ears are ornamented with three gold earrings each at the bottom of the  
 auricle.’ (Google)

(32) Komisja pracuje w zespołach złożonych z po dwóch  
 Commission works in teams consisting of DISTR two.GEN  
 przedstawicieli strony kościelnej i strony rządowej oraz po  
 representatives.GEN side church and side governmental and DISTR  
 jednym przedstawicielu organów nadrzędnych nad uczestnikami  
 one.LOC representative.LOC authorities superior to participants  
 postępowania.  
 proceedings  
 ‘(Church Property) Commission works in teams consisting of two rep-  
 resentatives each of the church side and the government side and of  
 one representative each of authorities superior to the participants of the  
 proceedings.’ (NKJP)

<sup>12</sup>We are grateful to Anna Kibort for pointing this out.



- (33) Prawie wszyscy zawodnicy występowali w po dwóch formacjach.  
 almost all players played in DISTR two.LOC formations.LOC  
 ‘Almost all players played in two formations each.’ (Google)

Similarly to (22)–(25), such examples are often judged marginal or even unacceptable by many native speakers, and as fully acceptable by others. It seems reasonable, then, to assume that the same lexical item is responsible for all these occurrences and that it is internalised in the grammars of different native speakers to various extents. The most conspicuous feature of this  $PO_{NUM}^{MOD}$  is that it is transparent to case assignment and simply transmits the case assigned to its position: nominative in (22)–(25) (and, perhaps, in the earlier (17)–(18), but see below), dative in (26)–(28), instrumental in (29)–(31), genitive in (32) and locative in (33). We conclude that  $PO_{NUM}^{MOD}$  cannot be analysed as a case-assigning preposition, but should rather be treated as an element transparent to case assignment, a modifier, perhaps an “adnumeral operator” in the sense of Grochowski 1997, §2.4.10. Below, in §3.3, we provide an HPSG analysis which – while preserving this intuition – still treats  $PO_{NUM}^{MOD}$  as a syntactic head, on a par with  $PO_{NUM}^{ACC}$  and  $PO_N$ .

### 2.3 The distribution of the three elements PO

It is easy to recognise  $PO_N$  – it occurs with nominal, not numeral phrases. On the other hand, it is not always clear which of the two adnumeral elements,  $PO_{NUM}^{ACC}$  or  $PO_{NUM}^{MOD}$ , surfaces in a given context. Consider the basic example (2) on p. 2. In the previous subsection we established that  $PO_{NUM}^{MOD}$  is transparent to case assignment, so it could be claimed that *po* in this example is a form of  $PO_{NUM}^{MOD}$  and that the accusative case on *dwa jabłka* ‘two apples’ reflects the accusative case assignment to the direct object. On the other hand, we also saw that at least in some adnumeral positions, namely (14)–(15), a different PO is needed,  $PO_{NUM}^{ACC}$ , which assigns the accusative case, and this  $PO_{NUM}^{ACC}$  could also be claimed to occur in (2). So now we have three ways of analysing (2): as involving  $PO_{NUM}^{ACC}$ , as involving  $PO_{NUM}^{MOD}$ , or as ambiguous between the two analyses.

Similarly, (13) on p. 4 could be analysed as involving  $PO_{NUM}^{ACC}$ , which assigns the accusative to *kilka owoców* ‘several fruit’, or as involving  $PO_{NUM}^{MOD}$ , transparent to the assignment of the accusative case to such numeral phrases in the subject position (cf. fn. 10 on p. 6), or as ambiguous between the two.

When deciding such cases, we take as crucial the observation of the previous subsection, namely, that occurrences of  $PO_{NUM}^{MOD}$  are rare, often judged as marginal or unacceptable. That is, since both (2) and (13) are fully acceptable, we assume that they involve  $PO_{NUM}^{ACC}$ . Note that this in principle does not exclude the possibility of the ambiguity between  $PO_{NUM}^{ACC}$  and  $PO_{NUM}^{MOD}$ , but the latter analysis will be more marginal than the former, perhaps altogether inaccessible to some speakers.<sup>13</sup>

<sup>13</sup>Also, if  $PO_{NUM}^{MOD}$  surfaced in (2), we would expect – contrary to facts – the numeral phrase to be able to occur in the genitive when the verb is negated or nominalised; see the discussion in §3.5 below, esp., around (45) on p. 16.

On the basis of these considerations we assume that the three elements PO surface in the following examples (this is a partial list; see below):

$PO_N$  – (1), (7)–(9), (10b)–(12b);

$PO_{NUM}^{ACC}$  – (2), (13)–(15), (20);

$PO_{NUM}^{MOD}$  – (22)–(33); perhaps marginally also in (2), (13) and (20).

The only two acceptable examples involving PO not classified here are (17)–(18), with paucal non-human-masculine numeral phrases following PO in the subject position. Such examples, while exhibiting subject–verb agreement and, hence, a nominative subject, are judged as acceptable by Łojasiewicz (1979, p. 154) and as significantly more acceptable than the clear cases of  $PO_{NUM}^{MOD}$  in (23) and (27) by Derwojedowa (2011, p. 145). As such, they seem to contradict the generalisation just proposed: since they occur in the nominative position and apparently contain a nominative NumP they should involve  $PO_{NUM}^{MOD}$ , but since they are acceptable, or at least clearly more acceptable than uncontroversial uses of  $PO_{NUM}^{MOD}$ , they should rather involve  $PO_{NUM}^{ACC}$ .

The following section presents an analysis which explains this contradiction away. According to this analysis, the acceptable (17)–(18) involve the accusative-assigning  $PO_{NUM}^{ACC}$ , so the numeral phrases *dwa fotele* ‘two armchairs’ and *trzy arkusze papieru* ‘three sheets of paper’ are taken to be accusative here. However,  $PO_{NUM}^{ACC}$  is not treated as an ordinary preposition here, but rather an element which may receive its own case – here nominative – and agree with the verb in number and gender.

With such a  $PO_{NUM}^{ACC}$  in hand, the final classification of all relevant examples above is as follows:

$PO_N$  – (1), (7)–(9), (10b)–(12b);

$PO_{NUM}^{ACC}$  – (2), (13)–(15), (17)–(18), (20);

$PO_{NUM}^{MOD}$  – (22)–(33); perhaps marginally also in (2), (13), (17)–(18) and (20).

### 3 HPSG Analysis

#### 3.1 Capturing generalisations

It might seem that postulating 3 lexical entries for function words with the same form and the same meaning is a clear case of a missing generalisation, but it is trivial to provide a description which states common properties of the 3 elements PO only once. We will assume here the simplest approach to the HPSG lexicon, namely, the Word Principle as construed in Höhle 1999 and Meurers 1999, i.e., essentially as the following constraint on *word* objects (where  $LE_i$  are lexical entries):

$$(34) \text{ word} \rightarrow LE_1 \vee LE_2 \vee \dots \vee LE_n$$

Given this general approach, commonalities between a number of lexical entries may be factored out as follows, where  $PO_{\text{com}}^d$  is a description common to all distributive elements PO, and  $PO_N^d$ ,  $PO_{\text{ACC}}^d$  and  $PO_{\text{MOD}}^d$  stand for the descriptions of other – more idiosyncratic – properties of  $PO_N$ ,  $PO_{\text{NUM}}^{\text{ACC}}$  and  $PO_{\text{NUM}}^{\text{MOD}}$ , respectively:

$$(35) \text{ word} \rightarrow \text{LE}_1 \vee \text{LE}_2 \vee \dots \vee (PO_{\text{com}}^d \wedge (PO_N^d \vee PO_{\text{ACC}}^d \vee PO_{\text{MOD}}^d)) \vee \dots \vee \text{LE}_n$$

### 3.2 Lexical entry for $PO_N$

We propose the following lexical entry for the preposition  $PO_N$ , before distributing it between  $PO_{\text{com}}^d$  and  $PO_N^d$ :

$$(36) \text{ PO}_{\text{com}}^d \wedge \text{ PO}_N^d \equiv \left[ \begin{array}{l} \text{ORTH } \langle po \rangle \\ \text{SS } \left[ \begin{array}{l} \text{CAT } \left[ \begin{array}{l} \text{HEAD } \left[ \begin{array}{l} \text{prep\_cased} \\ \text{CASE } str \end{array} \right] \\ \text{SUBJ } \langle \rangle \end{array} \right] \\ \text{VAL } \left[ \begin{array}{l} \text{COMPS } \langle \left[ \begin{array}{l} \text{CAT } \left[ \begin{array}{l} \text{HEAD } \left[ \begin{array}{l} \neg\text{numeral} \\ \text{CASE } loc \end{array} \right] \\ \text{SUBJ } \langle \rangle \\ \text{COMPS } \langle \rangle \end{array} \right] \\ \text{CONT } [2] \end{array} \right] \rangle \rangle \rangle \rangle \end{array} \right] \\ \text{CONT } \text{distributive}' ([2], [3]) \\ \text{COLL } [3] \end{array} \right] \end{array} \right]$$

According to this lexical entry,  $PO_N$  is a case-bearing preposition, *prep\_cased* (a subtype of *prep* and *cased*, the latter introducing the *CASE* attribute). Unlike proper (uncased) prepositions, such elements may occur in broadly nominal positions, i.e., in syntactic positions where case is assigned. Moreover, the *CASE* value is specified as *str*(uctural) – this accounts for the distribution of  $PO_N$  only in nominative, accusative and “secondary genitive” positions, i.e., exactly the structural case positions in Polish (Przepiórkowski, 1999).

While positing a cased preposition is highly non-standard, there is at least another such a preposition in Polish, namely, *OKOŁO*, which assigns the genitive case, as in the following example from Grochowski 1997, p. 73, where *Okolo stu kobiet* ‘around hundred women’ is the subject and the head numeral *stu* ‘hundred’ is in the genitive (the nominative form would be *sto*):<sup>14</sup>

$$(37) \text{ Około } stu \quad \text{ kobiet } \quad \text{ podpisało } \quad \text{ ten } \quad \text{ wniosek.} \\ \text{ around hundred.GEN women.GEN signed.3.N.SG this.ACC petition.ACC} \\ \text{ ‘Around a hundred women signed this petition.’}$$

Returning to  $PO_N$ , this preposition takes one complement which is specified as a saturated phrase in the locative case – but not a numeral phrase. This is empirically

<sup>14</sup>Somewhat similarly to the distributive multi-lexeme PO, this preposition *OKOŁO* co-exists with a homophonous and homosemous adnumeral operator *OKOŁO* (Grochowski, 1997, pp. 73–74); hence, *Okolo sto kobiet podpisało...* is also acceptable.

more adequate than saying the complement must be a noun phrase, since also some locative adjective phrases – so-called elective constructions – may appear here, as in the following example with the complement headed by the adjective form *najlepszej* ‘best’:

- (38) Komisja...                wybrała... po        najlepszej... ze złożonych  
 commission.NOM chose        DISTR best.LOC.SG of submitted.GEN  
 ofert        każdego wykonawcy.  
 offers.GEN every.GEN contractor.GEN  
 ‘The commission selected the best offer each from those submitted by every contractor.’ (Google)

Finally, the semantic impact of the distributive PO is only marked in (36), as the semantics of distributivity is complex and a matter of ongoing work (cf., e.g., Zimmermann 2002 and Dotlačil 2012). The key problem, which has led to some non-compositional treatments of the semantically analogous binominal EACH in English (as in *I gave them an apple each*, with *each* arguably attaching to the preceding NP; Safir & Stowell 1988), is that – apart from the nominal or numeral phrase to which such a distributive element attaches (so-called *distributed share*; Choe 1987), e.g., *jablku* ‘an apple’ in (1) – it also takes another semantic argument, which occurs elsewhere in the sentence (called *sorting key* in Choe 1987), e.g., *im* ‘them’ in (1). Moreover, contrary to what might be suggested by the simple constructed example (1), the *sorting key* may be both linearly and configurationally distant from PO (see, e.g., (7), where the *sorting key* is embedded within an adjunct PP), may be implicit and may even be contained within the *distributed share* itself (as, e.g., in (22)).

While we do not have a detailed HPSG analysis of the semantics of distributive PO to offer at present,<sup>15</sup> we envisage that the apparently non-compositional effects could be formalised in HPSG in terms of the COLL feature (Richter & Sailer, 1999), as explicated in Sailer 2003, § 8.2, possibly with restrictions argued for in Soehn 2004. A reference to the value of COLL, i.e., to the whole utterance (Sailer, 2003) or its appropriate constituent (Soehn, 2004), is needed in order to access the *sorting key* and compose it with the semantics of PO and the *distributive share*.

### 3.3 Lexical entry for $PO_{NUM}^{MOD}$

It is natural to represent  $PO_{NUM}^{MOD}$  as a modifier or a marker, as the whole  $PO_{NUM}^{MOD}$ -phrase behaves syntactically just as the following numeral phrase. On the other hand, we would like to factor out the semantics shared between the three distributive elements PO, i.e., minimally:

<sup>15</sup>But see Przepiórkowski 2013 for a Glue Semantics account compatible with the syntactic LFG analysis of Przepiórkowski & Patejuk 2013. It remains to be investigated whether the analysis presented in Przepiórkowski 2013 may be straightforwardly carried over to HPSG, e.g., building on Asudeh & Crouch 2002.

$$(39) \text{ PO}_{\text{com}}^d \equiv \left[ \begin{array}{l} \text{ORTH } \langle po \rangle \\ \text{SS } \left[ \begin{array}{l} \text{CAT|VAL|COMPS } \langle \text{CONT } [2] \rangle \\ \text{CONT } \mathbf{distributive}'([2], [3]) \end{array} \right] \\ \text{COLL } [3] \end{array} \right] \quad (\text{first version; cf. (41)})$$

But for this to be a common part of all distributive elements,  $\text{PO}_{\text{NUM}}^{\text{MOD}}$  (and  $\text{PO}_{\text{NUM}}^{\text{ACC}}$ , see below) – just like  $\text{PO}_{\text{N}}$  – must also be treated as a head, here subcategorising for a numeral phrase.

In HPSG, there is an obvious way to analyse marker-like elements as heads, namely, as *weak heads* in the sense of Tseng 2002, p. 273. In brief, weak heads, unlike classical HPSG markers, subcategorise for a complement, but they take over all syntactic and semantic properties of this complement, and add their own MARKER value. Abeillé 2003, 2006 adapts this notion to the analysis of French coordinating conjunctions in a way that requires the structure-sharing of syntactic (but not semantic) properties between the weak head and its complement. We will call such elements – sharing their syntax (but not necessarily their semantics) with their complements – *syntactically vacuous heads* here.<sup>16</sup>

The complete lexical entry for  $\text{PO}_{\text{NUM}}^{\text{MOD}}$  is given below:

$$(40) \text{ PO}_{\text{com}}^d \wedge \text{PO}_{\text{MOD}}^d \equiv \left[ \begin{array}{l} \text{ORTH } \langle po \rangle \\ \text{SS } \left[ \begin{array}{l} \text{CAT } \left[ \begin{array}{l} \text{HEAD } [1] \\ \text{VAL } \left[ \begin{array}{l} \text{SUBJ } \langle \rangle \\ \text{COMPS } \langle \left[ \begin{array}{l} \text{CAT } \left[ \begin{array}{l} \text{HEAD } [1] \textit{numeral} \\ \text{VAL } \left[ \begin{array}{l} \text{SUBJ } \langle \rangle \\ \text{COMPS } \langle \rangle \end{array} \right] \end{array} \right] \end{array} \right] \end{array} \right] \end{array} \right] \\ \text{CONT } [2] \end{array} \right] \\ \text{CONT } \mathbf{distributive}'([2], [3]) \end{array} \right] \\ \text{COLL } [3] \end{array} \right] \end{array} \right]$$

Note that there are no restrictions on the CASE value of  $\text{PO}_{\text{NUM}}^{\text{MOD}}$ , i.e., it may appear in any – also structural – case position. We will return to this issue in §3.5 below.

Comparing (40) with (36) above, we see that the following information may be factored out:

$$(41) \text{ PO}_{\text{com}}^d \equiv \left[ \begin{array}{l} \text{ORTH } \langle po \rangle \\ \text{SS } \left[ \begin{array}{l} \text{CAT|VAL } \left[ \begin{array}{l} \text{SUBJ } \langle \rangle \\ \text{COMPS } \langle \left[ \begin{array}{l} \text{CAT|VAL } \left[ \begin{array}{l} \text{SUBJ } \langle \rangle \\ \text{COMPS } \langle \rangle \end{array} \right] \end{array} \right] \end{array} \right] \\ \text{CONT } [2] \end{array} \right] \\ \text{CONT } \mathbf{distributive}'([2], [3]) \end{array} \right] \\ \text{COLL } [3] \end{array} \right]$$

Then the descriptions  $\text{PO}_{\text{N}}^d$  and  $\text{PO}_{\text{MOD}}^d$  boil down to the following:

<sup>16</sup>Note by the way that such *syntactically vacuous heads* are dual to the *semantically vacuous heads* of Pollard & Yoo 1998 and Przepiórkowski 1998, where only semantics is shared. This means that *weak heads* in the sense of Tseng 2002 may be treated as a derived notion and defined as the intersection of the set of syntactically vacuous heads and the set of semantically vacuous heads.

$$(42) \text{ PO}_N^d \equiv \left[ \text{SS|CAT} \left[ \begin{array}{l} \text{HEAD} \left[ \begin{array}{l} \textit{prep\_cased} \\ \text{CASE } \textit{str} \end{array} \right] \\ \text{VAL|COMPS} \langle \left[ \text{CAT|HEAD} \left[ \begin{array}{l} \textit{-numeral} \\ \text{CASE } \textit{loc} \end{array} \right] \right] \rangle \end{array} \right] \right]$$

$$(43) \text{ PO}_{\text{MOD}}^d \equiv \left[ \text{SS|CAT} \left[ \begin{array}{l} \text{HEAD} \boxed{1} \\ \text{VAL|COMPS} \langle \left[ \text{CAT|HEAD} \boxed{1} \textit{numeral} \right] \rangle \end{array} \right] \right]$$

### 3.4 Lexical entry for $\text{PO}_{\text{NUM}}^{\text{ACC}}$

Towards the end of §2.3 we noted that while  $\text{PO}_{\text{NUM}}^{\text{ACC}}$  assigns a specific case (namely, accusative) like prepositions do, it may still receive its own case and – when it bears the nominative case in the subject position – agree with the verb in number and gender (inherited from the numeral phrase). We claim that this behaviour is modelled well by treating  $\text{PO}_{\text{NUM}}^{\text{ACC}}$  as a kind of a syntactically vacuous head, like in case of  $\text{PO}_{\text{NUM}}^{\text{MOD}}$ . The only difference between these two elements would be that  $\text{PO}_{\text{NUM}}^{\text{ACC}}$  assigns the accusative to its complement and itself bears case – namely, structural, resolvable to nominative, accusative or (“secondary”) genitive.

This means that  $\text{PO}_{\text{NUM}}^{\text{ACC}}$  has the same case specification as  $\text{PO}_N$ : [CASE *str*]. But here similarities end:  $\text{PO}_{\text{NUM}}^{\text{ACC}}$  is a syntactically vacuous head taking over all other morphosyntactic features of its numeral complement, including the numeral part of speech. That is, with the right numeral (paucal and non-human-masculine), such a  $\text{PO}_{\text{NUM}}^{\text{ACC}}$ -phrase agrees with the verb in a nominative subject position, as in (17)–(18) above. On the other hand, we stipulate that prepositions do not agree with finite verbs, even when they bear the nominative case, as – by the current analysis – in (7) on p. 3.<sup>17</sup>

The following partial lexical entry for  $\text{PO}_{\text{NUM}}^{\text{ACC}}$ , with the part common to all distributive elements  $\text{PO}$  factored out in (41), reflects these considerations:

$$(44) \text{ PO}_{\text{ACC}}^d \equiv \left[ \text{SS|CAT} \left[ \begin{array}{l} \text{HEAD} \boxed{1 \setminus \text{CASE}} \left[ \text{CASE } \textit{str} \right] \\ \text{VAL|COMPS} \langle \left[ \text{CAT|HEAD} \boxed{1 \setminus \text{CASE}} \left[ \begin{array}{l} \textit{numeral} \\ \text{CASE } \textit{acc} \end{array} \right] \right] \rangle \end{array} \right] \right]$$

This description introduces new notation inspired by the LFG mechanism of re-

<sup>17</sup>This stipulation seems necessary, as phrases headed by the preposition  $\text{PO}_N$  arguably have INDEX so – when nominative – they would without it participate in the subject–verb agreement, which in Polish involves INDEX, not CONCORD (in the sense of Wechsler & Zlatic 2000; see Przepiórkowski et al. 2002). One argument for the claim that such  $\text{PO}_N$ -phrases have INDEX is that they apparently may act as controllers, as in the following attested example:

- (i) Do finału... zdołało zakwalifikować się po jednym bokserze Radomiaka  
to finals managed.3.SG.N qualify RM DISTR one.LOC boxer.LOC Radomiak.GEN  
i Polonii.  
and Polonia.GEN

‘One boxer from each of Radomiak and Polonia managed to qualify to the finals.’ (Google)

Another argument could be provided by binding, but acceptability of relevant examples is more difficult to ascertain.

striction (Kaplan & Wedekind, 1993).<sup>18</sup> In LFG,  $f \setminus \text{CASE} = g \setminus \text{CASE}$  means that the f-structures  $f$  and  $g$  are equal up to their values of CASE (if any). In (44) multiple occurrences of  $\boxed{1 \setminus \text{CASE}}$  indicate structures which are partially structure-shared, up to the value of the attribute CASE. That is, objects so described have the same type and they structure-share the values of all attributes apart from values of CASE (if this attribute happens to be among those appropriate to the given type at all). This in particular means that the HEAD value of  $\text{PO}_{\text{NUM}}^{\text{ACC}}$  will be *numeral*, just as the head of its complement, that they will share all morphosyntactic attributes appropriate to *numeral*, including NUMBER and GENDER, but they will differ in CASE as indicated in (44) –  $\text{PO}_{\text{NUM}}^{\text{ACC}}$  will have its case resolved to one of the morphological cases depending on the structural case position it will occupy (nominative, accusative or genitive), while its complement must always bear the accusative.

### 3.5 Analysis at work

Let us illustrate the analysis of this section with a few examples, starting with the most basic (1)–(2) on p. 2.

In (1), PO combines with a noun phrase, not a numeral phrase, so it cannot correspond to descriptions (43)–(44), which specify the complement to be *numeral*. On the other hand, (42) is applicable here, the locative case requirement is met by the noun phrase *jabłku* ‘apple.LOC’, and the cased preposition  $\text{PO}_N$  has its structural case resolved to nominative via case assignment principles like those described in Przepiórkowski 1999.

Conversely, (2) involves a numeral phrase, which is incompatible with the  $\neg$ *numeral* condition in (42). However, both (43) and (44) lead to an analysis of (2). According to (43), *po* shares its HEAD value with that of the numeral phrase *dwa jabłka* ‘two.ACC apples.ACC’, i.e., both are analysed as accusative numeral phrases. According to (44), *po* does not share its CASE with that of the numeral complement. However, it assigns accusative case to that complement, and it has its own structural case resolved to accusative via general structural case principles, so the result is virtually indistinguishable from the analysis involving (43). Thus, as it stands, the account produces spurious ambiguity in case of (2).

We see two ways of attacking this problem. First, as repeatedly mentioned above,  $\text{PO}_{\text{NUM}}^{\text{MOD}}$  is marginal, perhaps absent from grammars of some native speakers, so in any full-fledged grammar involving probabilities or Optimality Theory-like constraints, the analysis based on (43) will be blocked by that based on the fully acceptable (44). Unfortunately, current versions of HPSG do not take probabilities or ranking into account. Secondly, we may claim that (2) may only involve  $\text{PO}_{\text{NUM}}^{\text{ACC}}$  and not  $\text{PO}_{\text{NUM}}^{\text{MOD}}$ . Technically, a constraint could be added to (44) to the effect that it cannot occupy structural case positions:  $\neg[\text{CASE } \textit{str}]$ . One argument for this stronger claim is that  $\text{PO}_{\text{NUM}}^{\text{MOD}}$  seems impossible in structural (or “secondary”) genitive positions, e.g.:

<sup>18</sup>We emphasise that this is a matter of notation and not the underlying logical formalism, which we assume to be essentially that of Richter 2000.

- (45) \*Dzieci nie dostały po dwóch pączków.  
 children.NOM NEG received.3.PL DISTR two.GEN donuts.GEN  
 ‘The children did not get two donuts each.’ (intended; cf. (14))

In such positions, the numeral phrase may only bear the accusative case, as in (14)–(15) on p. 4, so only  $PO_{NUM}^{ACC}$  as specified in (44) may surface here.

Such a constraint would also prevent a similar spurious ambiguity in the analysis of (13) on p. 4, where *po* combines with *kilka owoców* ‘several.ACC fruit.GEN’. As a non-paucal numeral, *kilka* receives the accusative case in the subject position (cf. fn. 10 on p. 6), and since both  $PO_{NUM}^{ACC}$  and  $PO_{NUM}^{MOD}$  inherit the numeral characteristics of their complement, they also receive the accusative case (via the already mentioned general structural case assignment rules). So, for all intents and purposes, the subject position in (13) is a structural accusative position and two analyses are possible just as in case of (2) – unless we prohibit the analysis involving  $PO_{NUM}^{MOD}$  with a stipulation like  $\neg[CASE\ str]$  added to (43).

However, as it stands, the stipulation is too strong, as it would make (22)–(24) on p. 7 ungrammatical. These examples involve uncontroversially nominative paucal numerals agreeing with the verb and may be analysed only via  $PO_{NUM}^{MOD}$ . But if this element were forbidden from occupying any structural positions, it would also be prohibited in the structural nominative in (22)–(24), contrary to facts. For this reason, while it is possible to formulate a more complicated constraint limiting occurrences of  $PO_{NUM}^{MOD}$  to environments such as those in (22)–(24),<sup>19</sup> here we retain the version of the analysis which produces spurious ambiguities and assume that the choice between the analyses is made in other parts of the grammar (perhaps not expressible in contemporary HPSG).

Finally, let us consider the fully acceptable examples (17)–(18) on p. 5 involving numerals and NPs syncretic between nominative and accusative. Concentrating on (17), we note that  $PO_{NUM}^{ACC}$  assigns the accusative to *dwa fotele* ‘two armchairs’; all other morphosyntactic features are shared between *po* and the numeral *dwa*. Since *dwa* is a paucal agreeing numeral and the whole PO-phrase occurs in the subject position, the phrase receives the nominative case via general case principles. Hence, contrary to the initial grammatical glosses in (17), particular words in the subject phrase should bear the following grammatical features:

- (17') W pokojach będą po dwa fotele.  
 in rooms be.FUT.PL DISTR.NOM.PL two.ACC.PL armchair.ACC.PL  
 ‘There will be two armchairs in each room.’

Again, an analysis involving  $PO_{NUM}^{MOD}$  is in principle also possible here, but we assume that it is either blocked by the more acceptable analysis involving  $PO_{NUM}^{ACC}$  via mechanisms currently not expressible in HPSG or that a relevant constraint is

<sup>19</sup>Namely:  $[CASE\ str] \rightarrow \left[ \begin{array}{l} ACM\ congr \\ GENDER\ ml \end{array} \right]$ . See, e.g., Przepiórkowski & Patejuk 2012a,b about the ACM attribute (appropriate to numerals) and the *congr* type (of agreeing numerals); *ml* stands for human-masculine.



added to (43) blocking the occurrence of  $PO_{NUM}^{MOD}$  with non-human-masculine agreeing numerals (cf. fn. 19).

## 4 Conclusion

This paper deals with a very infrequent but intriguing phenomenon of distance distributivity in Polish involving function lexemes *PO*. We demonstrated that (at least) three distinct lexemes are needed to handle the variety of distributive constructions, but we also showed how these homophonous and at the same time homosemous lexemes may be encoded in a way that minimises redundancy in the lexicon and in the grammar. In particular, although case assignment properties of the three elements differ widely, with one of them actually being transparent to such case assignment, all three are analysed as heads of *PO*-phrases – the two adnumeral elements as syntactically vacuous heads. In the process, we also reaffirmed the usefulness of the LFG mechanism of restriction and proposed a shorthand for representing it in HPSG.

While dealing with a quirk in Polish, the analysis posits a more general question about the role of marginality – and, more generally, gradience – in HPSG: should it be represented via mechanisms known from the Optimality Theory (as in LFG), via tools specific to probabilistic parsing, or in yet another way? A number of talks at the HPSG 2013 conference suggested that answering this question is crucial for the further development of HPSG, and the current paper shares this position.

## References

- Abeillé, Anne. 2003. A lexicon- and construction-based approach to coordinations. In Stefan Müller (ed.), *Proceedings of the HPSG 2003 conference*, 5–25. Stanford, CA: CSLI Publications.
- Abeillé, Anne. 2006. In defense of lexical coordination. *Empirical Issues in Syntax and Semantics* 6. 7–36.
- Asudeh, Ash & Richard Crouch. 2002. Glue semantics for HPSG. In van Eynde et al. (2002) 1–19.
- Bogusławski, Andrzej. 2012. Polskie po dystrybucyjne: jednolitość ilościowego podziału zbiorowości. *Prilozi, oddelenie za lingvistika i literaturna nauka* XXXVII. 81–95.
- Borsley, Robert D. & Adam Przepiórkowski (eds.). 1999. *Slavic in Head-driven Phrase Structure Grammar*. Stanford, CA: CSLI Publications. <http://csli-publications.stanford.edu/site/1575861747.shtml>.
- Butt, Miriam & Tracy Holloway King (eds.). 2012. *The proceedings of the LFG'12 conference*. Stanford, CA: CSLI Publications. <http://csli-publications.stanford.edu/LFG/17/lfg12.html>.

- Choe, Jae-Woong. 1987. *Anti-quantifiers and a theory of distributivity*: University of Massachusetts, Amherst Ph. D. dissertation.
- Dalrymple, Mary (ed.). 1999. *Semantics and syntax in Lexical Functional Grammar: The resource logic approach*. Cambridge, MA: The MIT Press.
- Dalrymple, Mary. 2001. *Lexical-Functional Grammar*. San Diego, CA: Academic Press.
- Derwojedowa, Magdalena. 2011. *Grupy liczebnikowe we współczesnym języku polskim. Zarys opisu zależnościowego*. Warsaw: Uniwersytet Warszawski, Wydział Polonistyki.
- Dotlačil, Jakub. 2012. Binominal *each* as an anaphoric determiner: Compositional analysis. In Ana Aguilar Guevara, Anna Chernilovskaya & Rick Nouwen (eds.), *Proceedings of sinn und bedeutung 16: Volume 1*, vol. 16 MIT Working Papers in Linguistics, 211–224.
- Dziwirek, Katarzyna. 1990. Default agreement in Polish. In Katarzyna Dziwirek, Patrick Farrell & Errapel Mejías-Bikandi (eds.), *Grammatical relations: A cross-theoretical perspective*, Stanford, CA: CSLI Publications.
- Franks, Steven. 1995. *Parameters of Slavic morphosyntax*. New York: Oxford University Press.
- Grochowski, Maciej. 1997. *Wyrażenia funkcyjne. Studium leksykograficzne*, vol. 104 Prace Instytutu Języka Polskiego. Cracow: Wydawnictwo IJP PAN.
- Gruszczyński, Włodzimierz & Zygmunt Saloni. 1978. Składnia grup liczebnikowych we współczesnym języku polskim. *Studia Gramatyczne* II. 17–42.
- Harley, Heidi. 2006. *English words: A linguistic introduction*. Malden, MA: Blackwell.
- Höhle, Tilman N. 1999. An architecture for phonology. In Borsley & Przepiórkowski (1999) 61–90. <http://csli-publications.stanford.edu/site/1575861747.shtml>.
- Kaplan, Ronald M. & Jürgen Wedekind. 1993. Restriction and correspondence-based translation. In *Proceedings of the 6th conference of the European chapter of the Association for Computational Linguistics (EACL 1993)*, 193–202. Utrecht.
- Krasnowolski, Antoni. 1897. *Systematyczna składnia języka polskiego*. Warsaw: Drukarnia Estetyczna K. Sierpińskiego.
- Łojasiewicz, Anna. 1979. O budowie wyrażeń z przyimkiem *po* dystrybutywnym. *Polonica* V. 153–160.
- Małecki, Antoni. 1863. *Gramatyka języka polskiego*. Większa. Lwów.
- Meurers, Walt Detmar. 1999. *Lexical generalizations in the syntax of German non-finite constructions*: Universität Tübingen Ph. D. dissertation.
- Miechowicz-Mathiasen, Katarzyna & Jacek Witkoś. 2007. O podmiotach i ich

- przypadkach (w nawiązaniu do artykułów Zygmunta Saloniego i Adama Przepiórkowskiego). *Biuletyn Polskiego Towarzystwa Językoznawczego* LXIII. 101–114.
- Pollard, Carl & Eun Jung Yoo. 1998. A unified theory of scope for quantifiers and *wh*-phrases. *Journal of Linguistics* 34. 415–445.
- Przepiórkowski, Adam. 1998. ‘A Unified Theory of Scope’ revisited: Quantifier retrieval without spurious ambiguities. In Gosse Bouma, Geert-Jan M. Kruijff & Richard T. Oehrle (eds.), *Proceedings of the joint conference on Formal Grammar, Head-driven Phrase Structure Grammar, and Categorical Grammar*, 185–195. Saarbrücken: Universität des Saarlandes. <http://nlp.ipipan.waw.pl/~adamp/Papers/1998-fhcg/>.
- Przepiórkowski, Adam. 1999. *Case assignment and the complement-adjunct dichotomy: A non-configurational constraint-based approach*. Tübingen: Universität Tübingen Ph.D. dissertation. <http://nlp.ipipan.waw.pl/~adamp/Dissertation/>.
- Przepiórkowski, Adam. 2000. Long distance genitive of negation in Polish. *Journal of Slavic Linguistics* 8. 151–189. <http://nlp.ipipan.waw.pl/~adamp/Papers/2000-jsl/>.
- Przepiórkowski, Adam. 2004. O wartości przypadku podmiotów liczebnikowych. *Biuletyn Polskiego Towarzystwa Językoznawczego* LX. 133–143. <http://nlp.ipipan.waw.pl/~adamp/Papers/2003-bptj-case/>.
- Przepiórkowski, Adam. 2006a. O dystrybutywnym PO i liczebnikach jezykowych. *Polonica* XXVI–XXVII. 171–178. <http://nlp.ipipan.waw.pl/~adamp/Papers/2006-po/>.
- Przepiórkowski, Adam. 2006b. O inherentnej liczbie mnogiej liczebników ĆWIERĆ, PÓŁ i PÓŁTORA. *Poradnik Językowy* 9. 78–87. <http://nlp.ipipan.waw.pl/~adamp/Papers/2006-cwierc/>.
- Przepiórkowski, Adam. 2008. Generalised quantifier restrictions on the arguments of the Polish distributive preposition PO. *Études Cognitives* 8. 159–177. <http://nlp.ipipan.waw.pl/~adamp/Papers/2007-sk-po.cardinal/>.
- Przepiórkowski, Adam. 2010. Towards a Construction Grammar account of the distributive PO in Polish. *Études Cognitives* 10. 163–176. <http://nlp.ipipan.waw.pl/~adamp/Papers/2010-sk-po.CxG/>.
- Przepiórkowski, Adam. 2013. The semantics of distance distributivity in Polish: A glue semantics approach. To be submitted to *Empirical Issues in Syntax and Semantics 10* (CSSP 2013 Proceedings).
- Przepiórkowski, Adam, Anna Kupś, Małgorzata Marciniak & Agnieszka Mykowiecka. 2002. *Formalny opis języka polskiego: Teoria i implementacja*. Warsaw: Akademska Oficyna Wydawnicza EXIT. <http://nlp.ipipan.waw.pl/~adamp/Papers/2002-hpsg-book/>.

- Przepiórkowski, Adam, Mirosław Bańko, Rafał L. Górski & Barbara Lewandowska-Tomaszczyk (eds.). 2012. *Narodowy korpus języka polskiego*. Warsaw: Wydawnictwo Naukowe PWN.
- Przepiórkowski, Adam & Agnieszka Patejuk. 2012a. On case assignment and the coordination of unlikes: The limits of distributive features. In Butt & King (2012) 479–489. <http://csli-publications.stanford.edu/LFG/17/lfg12.html>.
- Przepiórkowski, Adam & Agnieszka Patejuk. 2012b. The puzzle of case agreement between numeral phrases and predicative adjectives in Polish. In Butt & King (2012) 490–502. <http://csli-publications.stanford.edu/LFG/17/lfg12.html>.
- Przepiórkowski, Adam & Agnieszka Patejuk. 2013. The syntax of distance distributivity in Polish: Weak heads in LFG via restriction. To appear in LFG 2013 proceedings.
- Richter, Frank. 2000. *A mathematical formalism for linguistic theories with an application in Head-driven Phrase Structure Grammar*: Universität Tübingen Ph.D. dissertation.
- Richter, Frank & Manfred Sailer. 1999. LF conditions on expressions of Ty2: An HPSG analysis of Negative Concord in Polish. In Borsley & Przepiórkowski (1999) 247–282. <http://csli-publications.stanford.edu/site/1575861747.shtml>.
- Safir, Ken & Tim Stowell. 1988. Binominal *each*. In *Proceedings of the north east linguistic society (nels)*, vol. 18, 426–450.
- Sailer, Manfred. 2003. *Combinatorial semantics and idiomatic expressions in Head-driven Phrase Structure Grammar*: Universität Tübingen Ph.D. dissertation.
- Saloni, Zygmunt. 1974. Klasyfikacja gramatyczna leksemów polskich. *Język Polski* LIV. 3–13, 93–101.
- Saloni, Zygmunt. 2005. O przypadkach w języku polskim (na marginesie artykułu Adama Przepiórkowskiego). *Biuletyn Polskiego Towarzystwa Językoznawczego* LXI. 27–48.
- Soehn, Jan-Philipp. 2004. License to COLL: How to bind bound words and readings to their contexts. In Stefan Müller (ed.), *Proceedings of the HPSG 2004 conference*, 261–273. Stanford, CA: CSLI Publications.
- Tseng, Jesse. 2002. Remarks on marking. In van Eynde et al. (2002) 267–283.
- van Eynde, Frank, Lars Hellan & Dorothee Beermann (eds.). 2002. *Proceedings of the HPSG 2001 conference*. Stanford, CA: CSLI Publications.
- Wechsler, Stephen & Larisa Zlatić. 2000. A theory of agreement and its application to Serbo-Croatian. *Language* 76. 799–832.
- Zimmermann, Malte. 2002. *'Boys buying two sausages Each' – on the syntax and semantics of distance distributivity*: Universiteit van Amsterdam Ph.D. dissertation.

# **Multiple case marking as case copying: A unified approach to multiple nominative and accusative constructions in Korean**

**Byong-Rae Ryu**  
Chungnam National University

Proceedings of the 20th International Conference on  
Head-Driven Phrase Structure Grammar

Freie Universität Berlin

Stefan Müller (Editor)

2013

Stanford, CA: CSLI Publications

pages 182–202

Ryu, Byong-Rae. 2013. Multiple case marking as case copying: A unified approach to multiple nominative and accusative constructions in Korean. In Stefan Müller (ed.), *Proceedings of the 20th International Conference on Head-Driven Phrase Structure Grammar, Freie Universität Berlin*, 182–202. Stanford, CA: CSLI Publications. DOI: 10.21248/hpsg.2013.10. 

## Abstract

This paper presents a unified approach to multiple nominative and accusative constructions in Korean. We identify 16 semantic relations holding between two consecutive noun phrases (NPs) in multiple case marking constructions, and propose each semantic relation as a licensing condition on double case marking. We argue that the multiple case marking constructions are merely the sequences of double case marking, which are formed by dextrorotatorily sequencing the pairs of the same-case marked NPs of same or different type. Some appealing consequences of this proposal include a new comprehensive classification of the sequences of same-case NPs and a straightforward account of some long standing problems such as how the additional same-case NPs are licensed, and in what respects the multiple nominative marking and the multiple accusative marking are alike and different from each other.

## 1 Introduction

This paper deals with multiple case marking constructions (MCCs) in Korean in a unified way. MCCs notably include multiple nominative constructions (MNCs) like in (1a) and multiple accusative constructions (MACs) like in (1b).<sup>1</sup>

- (1) a. ttokki-**ka** kuy-**ka** kkuth-**i** ppyocokha-ta.  
rabbit-NOM ear-NOM top-NOM be.pointed-DECL  
'The top of the ears of the rabbit is pointed.'  
b. Hans-ka ttokki-**lul** kuy-**lul** kkuth-**ul** cap-ass-ta.  
Hans-NOM rabbit-ACC ear-ACC top-ACC grab-PAST-DECL  
'Hans grabbed the top of the ears of rabbits.'

Multiple case marking can be observed in a single clause, as shown in (2).

- (2) haksayng-**i** yehaksayng-**i** ttokki-**lul** kuy-**lul** kkuth-**ul** cap-ass-ta.  
student-NOM girl student-NOM rabbit-ACC ear-ACC top-ACC grab-PAST-DECL  
'(The) girl students of students grabbed the top of the ears of rabbits.'

---

<sup>†</sup>Parts of this paper were presented at the Monthly Colloquium of the Korean Society for Language and Information (May 18, Seoul), the 20th International Conference on HPSG at Freie Universität Berlin (Aug. 26-29), and the Colloquium of the SFB 991 at the Heinrich-Heine Universität Düsseldorf (Aug. 19). I have benefited a lot from suggestions and criticisms from Chungmin Lee, Hee-Rahk Chae, Ick-Soo Kwon, Yong-hun Lee, Stefan Müller, Doug Arnold, Daniel Godard, Frank Van Eynde, Sebastian Löbner, Thomas Gamerschlag, Rainer Osswald, and the audiences of the colloquia and the conference. Any errors that occur in this paper are the sole responsibility of the author.

<sup>1</sup>The nominative case markers *-ka* and *-i* and the accusative case markers *-lul* and *-ul* are allomorphs, respectively. The former is post-vowel and the latter post-consonantal. The Yale Romanization System is used for the romanization of the Korean words. The abbreviations for the glosses used in this paper are as follows: NOM (nominative), ACC (accusative), GEN (genitive), DAT (dative), PRES (present tense), PAST (past tense), NLZ (nominalizer), REL (relative clause marker), DECL (declarative), QUE (question), LOC (locative), INST (instrumental), CL (classifier), GOAL (goal), TMP (temporal), SRC (source), HON (honorification), SUF (suffix), FOC (focus), and TOP (topic).

Given that a predicate can assign only as many cases as the number of arguments it subcategorizes for, the multiple occurrences of the same-case marked NPs are puzzling. This puzzling phenomenon poses a challenge not only to approaches in Head-driven Phrase Structure Grammar (HPSG) but also in other theories of grammar.

Despite numerous studies of MCCs, there still remain many unfinished puzzles that remain to be solved. There have been only few scattered attempts to explore the whole range of data in a balanced way. The majority of the previous works have mainly or exclusively focused on the double nominative constructions (DNCs), missing the crucial points concerning the questions of how DNCs are related to MNCs on the one hand, and to the double accusative constructions (DACs) on the other. Furthermore, the question of how DACs are related to MACs remains still to be answered in Korean linguistics.

The idea that insight into multiple identical case marking should be examined in more general contexts in Korean linguistics has been previously ignored. The set of NPs are marked with the identical case marker, nominative (1a) and accusative in (1b). It is also clear that the conceptual relationship between the same-case marked NPs is identical. I argue that double nominative marking is the simplest subtype of multiple nominative marking, which, together with multiple accusative marking, is in turn merely a subtype of multiple case marking. There are many pieces of evidence supporting insight into multiple case marking as systematically possible in the object as well as in the subject position.

This data is promising because it allows us to advance an integrated approach for multiple identical case marking. In this paper we show that this new insight enables us to find solutions to linguistic puzzles that previously eluded us.

This paper is organized as follows: In section 2, we show that only one NP of the same-case marked NPs is argument, and all other additional NPs are non-arguments. In section 3, we argue that multiple case marking is neither restricted to stative verbs nor to the sentence-initial position. In section 4, we critically review some previously proposed ideas about the grammatical status of the additional NPs. In section 5, we argue that at least 16 semantic types of sequences of identical case marked NPs should be assumed, showing that all these types are attested in MCCs. In section 6, we propose that the additional NPs are adjuncts which are listed in the value of the feature DEPS (for DEPENDantS). In section 7, we propose a mechanism of multiple nominative and accusative marking. In section 8, we illustrate how the proposal works, and finally draw a conclusion in section 9.

## **2 The Non-Argument Property of the Additional NPs**

If we adopt a standard view that there is a one-to-one relation between case assigner and case assignee, it is reasonable to assume that only one of the nominative case marked NPs is argument of the predicate, occurring in the subject position. Likewise, we assume that only one of the accusative case marked NPs is argument

of the transitive predicate, occurring in the object position. All the other additional same-case NPs are non-argument.

This non-argument property is one of the most important criteria for distinguishing MCCs from some other constructions in which two consecutive NPs happen to be marked with the same-case marker. While additional same-case marked NPs do not saturate the valency of a predicate in MCCs, there are some constructions in which two identically case-marked NPs are subcategorized for by a predicate, as can be seen in the psych-verb constructions in (3) and the copulative constructions in (4).

- (3) \*(John-**i**) \*(holangi-**ka**) silh-/mwusep-/cikyep-ta.  
 John-**NOM** tiger-**NOM** dislike-/fear-/be.tired.of-DECL  
 ‘\*(John) dislikes/fears/is tired of tigers.’ (psych-verb constructions)
- (4) \*(mwul-**i**) \*(elum-**i**) toy-ess-ta.  
 water-**NOM** ice-**NOM** become-DECL  
 ‘\*(Water) became ice.’ (copulative constructions)

Such examples as in (3) and (4) have been regarded as a type of MCCs in some works (e.g., Rhee (1999), Park (2001), Kim (2004a), and Cha (2008), among others). It is clear, however, that they do not share the non-argument property, since deletion of one of the two NPs would result in ungrammaticality.

Along the same lines, applicative formation as shown in (5) should be distinguished from MCCs, since the promoted argument – *Maria* in (5) – is an argument of the predicate.

- (5) Hans-ka  $\left\{ \begin{array}{l} \text{Maria-eykey} \\ \text{Maria-lul} \end{array} \right\}$  kkoch-ul cwu-ess-ta.  
 Hans-**NOM**  $\left\{ \begin{array}{l} \text{Maria-DAT} \\ \text{Mary-DAT/-ACC} \end{array} \right\}$  flower-**ACC** give-PAST-DECL  
 ‘Hans gave Maria flowers.’

For these reasons, we are not concerned here with psych-verb constructions or copulative constructions with two same-case NPs in them, rather we are proposing to exclude them from MCCs.<sup>2</sup> We also suggest that examples like in (5) are not MCCs.<sup>3</sup>

<sup>2</sup>This is not to say that these two constructions may not involve sequences of identical case marked NPs. It is possible to add additional nominative NPs to the position preceding to the first or the second NP. In other words, the two constructions can be MCCs, if more than three identical case marked NPs occur.

<sup>3</sup>One might ask whether or not there is any case where MACs has no counterpart in MNCs. The example set (5) might be regarded as one of the cases. But it is not an example of MCCs, as discussed above. So we may draw a conclusion that there is no case where MACs has no counterpart in MNCs. I credit Yong-hun Lee (p.c.) for pointing out this aspect of MCCs.



### 3 Restrictions on the Class of Predicates

In a series of articles (e.g., Kim (2004a), Kim (2004b), Kim et al. (2007)), Jong-Bok Kim claimed that the class of the predicates occurring in MNCs is confined to stative predicates, as can be seen in (6).

$$(6) \text{ SPR Lexical Rule (= (12), Kim et al. (2007); (34), Kim (2004b))}$$

$$v\text{-stative} \mapsto \left[ \begin{array}{l} v\text{-spr} \\ \text{VAL} \left[ \begin{array}{l} \text{SPR} \quad \langle \boxed{2}_i \rangle \\ \text{SUBJ} \quad \langle [\text{SPR} \langle \boxed{2} \rangle]_j \rangle \end{array} \right] \\ \text{SEM | RELS} \left\langle \dots, \left[ \begin{array}{l} \text{RELN} \quad \textit{subordinate} \\ \text{ARG1} \quad i \\ \text{ARG2} \quad j \end{array} \right], \dots \right\rangle \end{array} \right]$$

Multiple case marking, however, is observed in the clauses formed with various predicate types including intransitive stative verbs shown in (1a), transitive verbs (1b), ditransitive verbs (7), and activity verbs (8).

(7) Hans-ka na-eykey haksayng-**ul** yehaksayng-**ul** ponay-ess-ta.  
 Hans-NOM I-DAT student-ACC girl student-ACC send-PAST-DECL  
 ‘Hans sent me girl students of students.’

(8) haksayng-**i** yehaksayng-**i** na-eykey o-ass-ta.  
 student-NOM girl student-NOM I-DAT come-PAST-DECL  
 ‘Girl students of students came to me.’

The examples (1b) and (7)-(8) clearly show that multiple case marking is not confined to the stative verbs.

### 4 The Grammatical Status of Additional NPs

Regarding the grammatical status of additional NPs, two main streams of proposals are basically discernible.

One stream maintained that both NP<sub>1</sub> and NP<sub>2</sub> are subject, trying to define various notions of subject: e.g., Yu (1909) referred to them big and small subject, Yoon (2007) major and grammatical subject, and Lee (1997) subject [Spec, RefP] and subject [Spec, TP], respectively.

The other stream posited that only NP<sub>2</sub> is subject, proposing that NP<sub>1</sub> is topic or focus: e.g., Hong (2001) topic vs. subject; Rhee (1999) topic/focus vs. subject; Yoon (1986), Schütze (2001), Kim (2001, 2004a), and Kim et al. (2007) focus vs. subject; Park (2001) focused subject vs. subject; Choi (2012) sentential specifier vs. subject.

But there remain many essential problems unsolved in the first stream of reasoning, as partly pointed out by Chae & Kim (2008) among others. First of all, a clause with more than one subject is highly at odds with a perspective on the

theory of grammar . Second, there is no straightforward answer to the question of what the logical structure of the clause looks like. Third, the relationship between the various notions of subject – be it big or small, or major or grammatical – is extremely vague.<sup>4</sup> Fourth, there is no convincing independent evidence for assuming the various notions of subject in Korean and in other languages. Fifth, there are clear difficulties in answering the question as to how the clauses can be interpreted. Finally, there is one more problem which has been touched on from time to time but not explored in detail. This problem comes from the observation that the multiple case-marking phenomenon is not restricted merely to nominative cases, but also observed in accusative case marking. For these reasons, any attempt to wrestle with the various notions of subject may result in confusion of the issue.

Most analyses advancing the second stream of reasoning have been proposed within the framework of Head-driven Phrase Structure Grammar (HPSG, Sag et al. (2003)). Kim (2004a) and Kim et al. (2007), most notably, proposed an analysis which basically has three components: First, the feature SPR and the Head-SPR rule, besides SUBJ, are introduced as in (9a). Second, the value of SPR is introduced via SPR Lexical Rule (6) under the constraint of *subordinate*, a notion borrowed from Na & Huck (1993).<sup>5</sup> Third, NP<sub>1</sub> – the value of SPR – is nominative-marked by the constructional constraint *focus-clause*, as formalized in (9b).

- (9) a. Head-SPR Rule (= (33), Kim (2004a); cf. (12), Kim et al. (2007))  

$$\left[ \text{hd-spr-ph} \right] \rightarrow \left[ \text{NP}, \text{H} \left[ \text{SPR} < \left[ \right] > \right] \right]$$
- b. *focus-clause* (= (14), Kim et al. (2007); a revision of (37), Kim (2004a))  

$$\left[ \text{RELS} \left\langle \left[ \begin{array}{l} \text{PRED } \textit{characterized-by} \\ \text{ARG1 } h3 \\ \text{ARG2 } h4 \end{array} \right] \right\rangle \right] \rightarrow \text{NP} \left[ \begin{array}{l} \text{GCASE } \textit{nom} \\ \text{FOCUS } + \\ \text{LBL } h3 \end{array} \right], \text{S} \left[ \text{LBL } h4 \right]$$

This analysis, however, encounters at least three non-trivial problems.

First, given the general consensus that Korean is a specifier-less language, the rule in (6) lacks empirical independent motivation. Note that, unlike in English or German, a (common) noun does not subcategorize for a specifier in Korean.<sup>6</sup>

Second, this analysis as it is formalized in (6) cannot account for multiple nominative constructions, since the Head-SPR rule may be applied at most once. For multiple nominative constructions, Kim (2004a) and Kim et al. (2007) assumed that SPR takes a list with more than one NP as its value. But this analysis again faces the first problem.

The first and the second problem become more evident in the sentences where

<sup>4</sup>See Park (2001) for a critical discussion.

<sup>5</sup>Choi (2012) proposed a similar analysis, according to which the initial NP is a sentential specifier. As a condition on licensing of the sentential specifier, he assumed a (pragmatic) notion of *aboutness* instead of *subordinate*. He disputed the position that the initial NP is a focus. The focus analysis was criticized by Yoon (2007) in detail.

<sup>6</sup>Moreover, the feature SPR is *ad hoc* in the sense that it is assumed exclusively for double/multiple nominative constructions.

a proper noun such as *Payktamsa* (Baekdamsa Temple) occurs in the multiple nominative constructions as shown in (10).

- (10) Selaksan-i      Payktamsa-ka              tanpwung-i              alumtap-ta.  
 Mt. Selak-NOM Paekdamsa Temple-NOM autumn leaves-NOM be.beautiful-DECL  
 ‘Autumn leaves are beautiful around Paekdamsa Temple in Mt. Selak.’

Third, the semantic constraint *subordinate* is obviously not enough to correctly predict the grammaticality of the sentences. For example, the relationship between *tomato* and *worm* is not subsumed by *subordinate*, but the sentence (11) is grammatical.

- (11) thomatho-ka pellye-ka      tulkkulh-nun-ta.  
 tomato-NOM worm-NOM be.infested-PRES-DECL  
 ‘Tomatoes are infested with worms.’

As can be seen in Table 1, the *subordinate* relations cover only 5 out of 16 subtyping of multiple case marking constructions.

## 5 Licensing of the Additional NPs

The effort to find the generative source of the sequences of same-case NPs in some semantic relationships between the two consecutive nominative NPs goes back to Yang (1972).<sup>7</sup> He argues that the ‘macro-micro relation’ is one of the generative sources, refuting the genitive view.<sup>8</sup> This relation refers to a relation where an NP is conceptually divided into the whole NP itself and a subpart of it. The NP which corresponds to the former is referred to as a macro-NP, while the NP corresponding to the latter is referred to as a micro-NP. Yang (1972, 42ff.) classifies this macro-micro relation into 5 subtypes on the basis of their semantic contents: (i) whole-part, (ii) class-member, (ii) type-token, (iii) total-quantity, and finally (v) affected-affecter.<sup>9</sup>

The licensing issue has been tackled again by Na & Huck (1993). They proposed that the two consecutive nominative case-marked NPs need to be in a certain semantic relation, called ‘thematic subordination’: X is ‘thematically subordinate’ to an entity Y iff. Y’s having the properties that it does entails that X has the properties that it does. Na & Huck (1993, 195) classify these thematic subordination

<sup>7</sup>This section is based on Ryu (2013).

<sup>8</sup>For other generative sources of the multiplication of case markers, Yang (1972, 159 & 195) added two groups of verbs. One group includes verbs of self-judgment (e.g., *siphata* (to be desirous of), *cohta* (to be fond of), *kippata* (to be glad), *masissta* (to be tasty), etc.) and verbs of semi-self-judgment (e.g. *philyohata* (to be necessary), *chwungpwunhata* (to be enough), *kanunghata* (to be possible), *swipta* (to be easy), etc.). The other group Yang (1972, 175) adds is verbs of existence (*issta* (to exist), *epta* (not to exist), *manhta* (to exist a lot), and *cekta* (to exist a few)). The first group may well be regarded as psych-verbs.

<sup>9</sup>According to Yang (1972, 45), the affected-affecter macro-micro relation is a ‘solidarity’ relation and some sort of natural pairing, e.g., kinship, teacher-student, society-individual, etc. We do not assume this relation as an independent class, but regard it as an instance of conversive relation.

relations into five subtypes: (i) part-whole relation, (ii) qualitative relation, (iii) conventional relation, (iv) converse relation, and (v) taxonomic relation.

The part-whole relation and the taxonomic relation in Na & Huck (1993) correspond to the whole-part and the class-member relation in Yang (1972), respectively. The other three relations — qualitative, conventional, and converse — have been recently proposed. The *thematic subordinate* relations have been adopted as licensing conditions in subsequent work in the field of Korean linguistics (see Kim (2004a), and Kim et al. (2007), among others).

Such terms as whole-part, (inalienable/alienable) possessor-possessum, kinship, thing-property, locative-theme etc. have sometimes been adopted in the literature, and used to name the whole constructions at the same time (see Choi (2008, 902) for a critical survey). However, at least three pieces of desiderata of this tradition may be pointed out.

First of all, the definitions of each term are not clear in many cases. For example, the whole-part relation has been interchangeably used with the inalienable possessor-possessum relation in many works. As will be clear below, however, inalienable possessor-possessum relation is only a subtype of six subtypes of the meronymic relation, and not all subtypes of the whole-part relation share the same properties with the inalienable possessor-possessum relation. This is one of the major sources of confusion found in many previous studies.

Another point of desiderata can be found in sentences like (12), which Yang (1972, 43) regarded as an example of part-whole relation. However, a closer examination reveals that they do not stand in part-whole relation, since *sayk* (color) is not a part of *mwucikay* (rainbow).

- (12) ce mwucikay-ka sayk-i kop-ta.  
 that rainbow-NOM color-NOM be.pretty-DECL  
 ‘That rainbow’s color is pretty.’ (= (2b), Yang (1972: 43))

A third piece of desiderata in previous work on the topic is the incompleteness of classification. As will be clear soon, there are many other semantic relations which are responsible for the multiplication of same-case NPs in Korean, but they have received little attention.

To remedy these desiderata, we start our discussion by advancing some important achievements of mereology and taking into consideration some data, which have been discussed less frequently in the literature.

## 5.1 Meronymic Relations

Whole-part relations or meronomies gave rise to a wide range of studies in linguistics, psychology, philosophy and artificial intelligence (cf. Cruse (1986), Iris et al. (1988) and Winston et al. (1987)). Based on psycholinguistic experiments and the way in which the parts contribute to the structure of the wholes, Winston et al. (1987) determined six types of part-whole relations: (i) component-integral object, (ii) member-collection, (iii) portion-mass, (iv) stuff-object, (v) feature-activity, and

(vi) place-area. We adopt the definitions and the type classification of meronymic relations in Winston et al. (1987), and argue that all six types should be assumed for licensing of the sequences of same-case NPs.

**Type 1 Integral object-component** The integral object-component relation is a relation between components and the objects to which they belong. Integral objects have a structure; their components are separable and have a functional relation with their wholes (e.g., *elephant-nose*, *person-leg*, *bike-pedal*, *tree-bark*, *opera-aria*, *cup-handle*, *car-wheel*, *person-hand*, *person-hair*, etc.).

**Type 2 Collection-member** The collection-member relation represents membership in a collection. Members are parts, but they cannot be separated from their collections and do not play any functional role with respect to their whole (e.g., *fleet-ship*, *army-soldier*, *faculty-professor*, *forest-tree*, *deck-card*, etc.). Collection must be distinguished from classes. The class-membership relation (see Type 7 Class-membership below) is not a meronymic relation, because it is not expressed by ‘part’, but by ‘is’.

**Type 3 Mass-portion** Mass-portion captures the relations between portions and masses, extensive objects, and physical dimensions. The parts are separable and similar to each other and to the wholes which they comprise, and do not play any functional role with respect to their whole (e.g., *pie-slice*, *kilometer-meter*, *salt-grain of salt*, *cake-piece*, etc.).

**Type 4 Object-stuff** The object-stuff category encodes the relations between an object and the stuff of which it is partly or entirely made. The parts are not similar to the wholes that they comprise, cannot be separated from the whole, and have no functional role (e.g., *car-steel sheet*, *desk-wood*, *bike-steel*, etc.).

**Type 5 Feature-activity** The feature-activity relation captures the semantic links within features or phases of various activities or processes. The parts have a functional role, but they are not similar or separable from the whole (e.g., *golf-putting*, *eating-swallowing*, *shopping-paying*, *eating-chewing*, etc.).

**Type 6 Area-place** Area-place captures the relation between areas and special places and locations within them. The parts are similar to their wholes, but they are not separable from them (e.g., *Korea-Seoul*, *Europe-Germany*, *desert-oasis*, etc.).

## 5.2 Inclusion Relations

**Type 7 Class-membership** Class-membership or hyponymy is not a part-whole relation, and usually expressed in the frames, ‘Xs are type of Y’, ‘Xs are Ys’, ‘X is a kind of Y’, and ‘X is a Y’ (Cruse (1986, 89)). Class inclusion and meronymy (especially, collection-membership) are clearly distinguished when expressed by ‘kind of’ and ‘part of.’ (e.g., *flower-rose*, *airplane-777*, *fruit-apple*, *tree-oak*, *furniture-chair*, *tool-saw*, *bird-sparrow*, *clothes-shirt*, *games-soccer*, etc.).<sup>10</sup>

---

<sup>10</sup>This relation properly includes the type-token relation (sun vs. rising sun) in Yang (1972), since ‘rising sun’ is a kind of ‘sun’. Free relatives with bound nouns like *kos* (place) and *pwun* (honored person) may be regarded as an example of class-membership.

**Type 8 Object-attachment** Pairs such as *ear-earring*, *chimney-TV antenna*, and *fishing line-hook* do not express a part-whole relation, since the latter may be attached to, but not parts of the former. This relation, which we call object-attachment relation, might be confused with meronymy, since the relation paraphrased by ‘to be attached to’ can be also observed in whole-part relations.

### 5.3 Quality-Quantity Relations

**Type 9 Object-quality** Object-quality relation captures one of qualities of entity. The objects may or may not have a structure, their properties have a characterizing function (e.g., *tool-use*, *pants-length*, *person-height*, *eyes-color*, *skin-texture*, *room-temperature*, *food-taste*, *hair-shine*, etc.).

**Type 10 Object-quantity** Object-quantity relation captures a relation between the object and its floated quantifiers (e.g., *student-number CL*, *horses-number CL*, *water-number CL*, *car-number CL*, *apple-number CL*, etc.).

### 5.4 Spatio-Temporal Relations

**Type 11 Space-object** Space-object relation represents a relation between an object and the space in which it is placed (e.g., *container-crack*, *tomato-worm*, *beach-girl*; *city-weather*, *kids-illness*, etc.).

**Type 12 Time-object** Time-object relation captures a relation between an object and the time in which it occurs (e.g., *summer-beer*, *autumn-weather*, *nowadays-camera*, *spring-flowers*, *yesterday-body*, *tomorrow-kids*, *that time-cinema*, etc.).

### 5.5 Predication Relations

**Type 13 Possessor-object** Possessor-object, in general, is an asymmetric relationship between two constituents, the referent of one (= the possessor) which possesses the referent of the other (= the object). X and Y may enter into a possessor-object relation, if their relations may be characterized by such predicates as *have*, *own*, and *rules over*. Alienable and inalienable possession are commonly distinguished. We understand only the alienable possession under Type 13 possessor-object relation. The inalienable possession is a proper portion of Type 1 integral object-component relation.

**Type 14 Conventional relation** Conventional relation captures relations in which some entity X is related to some individual Y by virtue of convention, rather than as a consequence of their inherent properties. Following Cruse (1986) and Na & Huck (1993), we’ll call these relationships conventional. (e.g., *man-car*, *woman-picture*, *car-smell*, *tiger-area of movement*, *girl-dog*, *boy-hat*, *bird-nest*, *animal-territory*, *person-clothes*, etc.) There are in principle a variety of conventional relations into which X and Y may enter if a conventional relation holds between X and Y, and these relations may be more accurately characterized by a variety of predicates other than *have* (cf. Na & Huck (1993, 197).

**Type 15 Object-predication** Object-predication captures an asymmetric relation between two consecutive NPs; the referent of the one is construed to be agent or theme argument of the other (e.g., *person-complaint*, *father-love*, *bomb-explosion*, *car-acceleration*, *ship-voyage*, etc.). The NPs expressing predication are typically Sino-Korean verbal nouns like *pwulphyeng* (complaint), but they can be gerunds formed by attaching a derivational suffix *-ki* or *-um* as *ilk-ki* (reading).<sup>11</sup>

**Type 16 Conversive relation** Following Na & Huck (1993), we define conversive relation as a (roughly symmetric) relation in which the entities denoted by the first nouns are in the relevant cases construed to be in institutional hierarchies to the entities denoted by the second nouns with which they are paired (e.g., *parent-child*, *master-servant*, *employer-employee*, *husband-wife*, *doctor-patient*, *host-parasite*, etc.). The kinship relations, the social relations, and the affector-affected relation in Yang (1972) are subsumed by the conversive relation.

## 5.6 Summary and Conceptual Linking Constraints

So far, we introduced 16 semantic relations which can be observed in the context of MNCs or MACs. They are summarized as in Table 1.<sup>12</sup>

Table 1: Types of Multiple Case Marking Constructions (Ryu (2013))

Proposed type of MCCs	NOM-NOM	ACC-ACC	Yang (1972)	Na & Huck (1993)
<b>Type 1</b> integral obj.-component	○	○	whole-part	meronomic rel.
<b>Type 2</b> collection-member	○	○	×	×
<b>Type 3</b> mass-portion	○	○	×	×
<b>Type 4</b> object-stuff	○	○	×	×
<b>Type 5</b> activity-feature	○	○	×	×
<b>Type 6</b> area-place	○	○	×	×
<b>Type 7</b> class-membership	○	○	class-member type-token	taxonomic rel.
<b>Type 8</b> object-attachment	○	○	×	×
<b>Type 9</b> object-quality	○	○	×	qualitative
<b>Type 10</b> object-quantity	○	○	total-quantity	×
<b>Type 11</b> space-object	○	*	×	×
<b>Type 12</b> time-object	○	*	×	×
<b>Type 13</b> possessor-object	○	*	×	
<b>Type 14</b> conventional relation	○	*	×	conventional
<b>Type 15</b> object-predication	○	*	×	×
<b>Type 16</b> conversive relation	○	*	affected-affector	conversive

It is important to note that, while all types are attested in MNCs in Korean, Type 11-Type 16 are not attested in MACs, but only in MNCs (see Ryu (2013) for a detailed discussion). Based on the semantic relations discussed above, I propose the following hierarchy as a licensing condition for the additional NPs. More

<sup>11</sup>The object-predication relation is a major source of multiple same-case marking in verbal noun constructions, in which the functional verbs *hata* (to do) and *toyta* (to become) are used to form active and passive sentences, respectively (see Ryu (1993) for details).

<sup>12</sup>Rel. is an abbreviation for ‘relation’ and con. for ‘constructions’. The symbol \* refers to ‘impossible’, and × ‘not mentioned’.

specifically, I propose the nominative case is shared between the two consecutive NPs, if one of the *conceptual relation* holds between them, while the accusative case is shared between the two consecutive NPs, if one of the *intrinsic relation* holds between them. In this sense, multiple accusative marking is more restrictive than multiple nominative marking, as previously speculated without any detailed discussion.

(13) Conceptual Linking Hierarchy

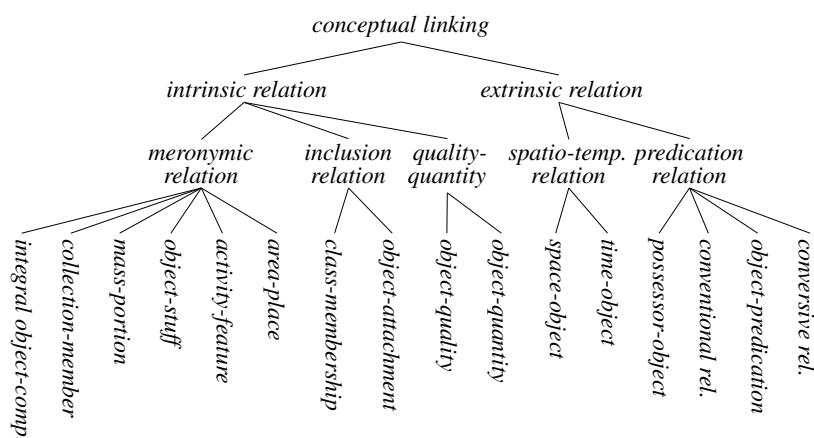

The conceptual linking hierarchy sketched in (13) has many advantages over the previous analyses. First, it amounts to the claim that there are at least 16 different types of multiple nominative constructions, exempting such attempts to report further types of multiple nominative constructions as Kim et al. (2007) did. Second, it gives an answer to the long standing question how the additional nominative NPs are licensed. Third, it provides us with an answer to the question of in what respects the multiple nominative and accusative constructions are similar and different from each other. In my view, multiple nominative case marking is basically only possible if the conceptual relation between the two consecutive NPs is a type subsumed by the types *intrinsic relation* and *extrinsic relation*, whereas the conceptual relation between the two consecutive accusative NPs is a type subsumed by the type *intrinsic relation*. Fourth, it provides a starting point in answering the question of how one might process the semantic and pragmatic contributions of interpretation to the sentence as a whole.

## 6 Adjunct in MCCs

In this section, I show that only the right-most NP is the subject or object, and the other additional same-case marked NPs are adjuncts.

### 6.1 Head of the Sequence as Argument

It has been pointed out in the literature that the well-known subjecthood tests reveal that the right-most NP is the subject. If we will concentrate on the DNCs, for



example, the honorific suffix *-si*, which is known to be controlled by the subject, is triggered by the right-most NP. Reflexivization can be controlled by the right-most NP, and the plural copying phenomena also shows that the right-most NP is the subject. Interestingly enough, however, Park (2001, 164) pointed out that all the three arguments can also be used to show that the left-most NP is the subject. Based on this observation, he concluded that both the left-most and the right-most NP may be the subject.

But the selectional restrictions of the predicate show that only the right-most NP in each sequence of the same-case marked NPs is the argument of the predicate. There are at least three pieces of evidence supporting this view.

First, let us examine the sentence in (1a). What is predicated of by the predicates *ppyocokhata* (be pointed) is not the left-most NP *ttokki* (rabbit), but the right-most NP *kkuth* (top). This observation shows that the left-most NP is the argument of the predicate.

Another piece of evidence comes from a sentence like (14), where the same set of NPs combines with two different predicates. The sentence (14b) is ungrammatical, since the NP *elkwul* (face) violates the selectional requirement of the verb *chayphohata* (to arrest). If the predicates would select the left-most NP, *John*, both the sentences in (14) would be grammatical.

- (14) a. Mary-ka John-ul elkwul-ul ttayli-ess-ta.  
 Mary-NOM John-ACC face-ACC hit-PAST-DECL  
 ‘Mary hit John’s face.’  
 b. \*Mary-ka John-ul elkwul-ul chayphoha-ess-ta.  
 Mary-NOM John-ACC face-ACC arrest-PAST-DECL

One further example shows that only the right-most NP is selected for by the predicate, too. The sentence (15b) is ungrammatical, since the verb *masita* (to drink) requires an NP having the feature [-integrated], whereas the verb *ppalta* (suck) selects an NP[+integrated] (example from Cho & Lee (2003)). (15b) is ungrammatical, since the right-most NP, *phi* (blood), does not satisfy the selectional requirement [-integrated] posed by the verb *masita* (to drink).

- (15) a. Vampire-ka John-ul phi-lul ppal-ass-ta  
 Vampire-NOM John-ACC blood-ACC suck-PAST-DECL  
 ‘A vampire sucked John’s blood.’ (Type 1 Integrated object-component)  
 b. \*Vampire-ka John-ul phi-lul masi-ess-ta  
 Vampire-NOM John-ACC blood-ACC drink-PAST-DECL

What all those arguments show after all is that the right-most argument of a sequence of the same-case marked NPs is the argument of the predicate.

## 6.2 Evidence for the Adjuncthood of the Additional NPs

If we adhere to the traditional view on valence values, the only valence available is the adjunct. As we pointed out above, SUBJ, COMPS and SPR should be excluded. We propose that, in fact, the additional case-marked NPs are adjuncts.

There are many pieces of evidence supporting this proposal, though not all of them are sufficient and necessary.

First, there is no theoretical limit of the number of the additional NPs occurring in the multiple case marking constructions. Second, the additional NPs are not subcategorized for by the predicate. Third, unlike in English or German, a (common) noun does not subcategorize for a specifier in Korean. Fourth, even proper nouns can occur in the multiple case marking constructions. The fifth evidence comes from the behavior of manner adverbs like *seykkey* (hard), which can occur between the same-case marked NPs.

- (16) a. Mary-**ka** John-**ul** tali-**lul** **seykey** cha-ass-ta.  
 Mary-NOM John-ACC leg-ACC hard kick-PAST-DECL  
 ‘Mary kicked John’s leg hard.’  
 b. Mary-**ka** John-**ul** **seykey** tali-**lul** cha-ass-ta.  
 Mary-NOM John-ACC hard leg-ACC kick-PAST-DECL  
 c. Mary-**ka** **seykey** John-**ul** tali-**lul** cha-ass-ta.  
 Mary-NOM hard John-ACC leg-ACC kick-PAST-DECL

Manner adverbs like *seykey* (hard) can occur between the consecutive NPs. The example (16) shows that the consecutive NPs do not form a constituent. The arguments above enable us to suggest that the additional non-argument NPs are adjuncts.

### 6.3 Adjuncts in HPSG

In HPSG, adjuncts combine syntactically with the phrases that they modify semantically in terms of modifier-head structures. Adjuncts are endowed with a specification for the feature MOD, whose value must be identified with (the SYNSEM of) the head daughter in a Head-Adjunct Structure. This type of analysis is adequate for a wide range of cases to which it is commonly applied.

However, Bouma et al. (2001) reported that in many languages types of adverbials defy any simple analysis in terms of the syntactic the combination of modifiers and heads. We believe that the adjuncts in MNCs in Korean also defy the standard treatment. Although we are not concerned with the passive MNCs, they seem to suggest that they should be dealt with in a way different from ‘pure’ adverbials. Passive converts a double accusative sentence into a double nominative sentence. The sentence (17a) has one of the passive counterparts of (17b), where the two consecutive NPs are marked with the same case.

- (17) a. Hans-ka John-**ul** tali-**lul** cha-ess-ta  
 Hans-NOM John-ACC leg-ACC kick-PAST-DECL  
 ‘Hans kicked John’s leg.’ (active: ACC-ACC)  
 b. John-**i** tali-**ka** cha-i-ess-ta  
 John-NOM leg-NOM kick-PASS-PAST-DECL  
 ‘John’s leg was kicked.’ (passive: NOM-NOM)

- c. John-**i** tali-**lul** cha-i-ess-ta  
 John-**NOM** leg-**ACC** kick-PASS-PAST-DECL  
 ‘John’s leg was kicked.’ (passive: NOM-ACC)

Interestingly enough, the sentence (17a) has another passive counterpart (17c), where only the left-most NP is marked with nominative, the case of the other NPs remains unchanged, i.e. in accusative. Although this peculiar behavior of the passive MCCs is observed only in highly restricted subtypes of MCCs, e.g. Type 1 integrated object-component, it suggests that the adjuncts should be specified in the lexical entry of the predicate. Following the basic idea of Bouma et al. (2001, 39), we assume Argument Structure Extension (18) and Argument Realization (19).

- (18) Argument Structure Extension (cf. (65), Bouma et al. (2001, 39))

$$verb \Rightarrow \left[ \begin{array}{ll} \text{HEAD} & \boxed{3} \\ \text{ARG-ST} & \boxed{1} \\ \text{DEPS} & \boxed{1} \oplus list \left( \left[ \begin{array}{l} \text{HEAD } noun \\ \text{MOD} \left[ \begin{array}{l} \text{HEAD} \boxed{3} \\ \text{RELS} \boxed{2} \end{array} \right] \end{array} \right] \right) \\ \text{SEM | RELS} & \boxed{2} \end{array} \right]$$

- (19) Argument Realization (cf. (11), Bouma et al. (2001, 11))

$$word \Rightarrow \left[ \begin{array}{ll} \text{SUBJ} & \boxed{1} \oplus \boxed{A} \\ \text{COMPS} & \boxed{2} \oplus \boxed{B} \ominus list(gap-ss) \\ \text{DEPS} & \boxed{2} \oplus \boxed{B} \oplus \boxed{1} \oplus \boxed{A} \end{array} \right]$$

To preserve the distinction between adjuncts and truly selected arguments, we will assume first the level of ARG-ST, which contains all and only the selected arguments of a lexical head. In addition, we introduce dependency structure as an extended argument structure. The feature DEPS specifies the list of dependents of a lexical head. In the case of verbs, these are the selected arguments plus an underspecified list of nominal modifiers. We leave open whether adverbial *synsems* in general are specified in the list of DEPS in Korean. The relationship between ARG-ST and DEPS is defined by means of Argument Realization (19).

(18) allows a verb’s DEPS list to contain any number of nominal modifiers in addition to the verb’s arguments. Moreover, the MOD|HEAD value of the nominal modifier is identified with the HEAD value of the verb on whose DEPS list the nominal modifier appears.

## 7 Multiple Nominative and Accusative Case Marking

Focus analyses such as in (9b) have been challenged by many researchers (cf. Yoon (2007) and Choi (2012) among others). The main argument against the focus of the additional NPs centers around the observation that not all the additional NPs function as focal points. Partly agreeing with Yoon (2007), I assume that only a subset of the additional NPs can be interpreted as foci - a new information of an

utterance – within the topic-focus framework of the functional sentence perspective dating back to Prague school. It can be assumed that a non-truth-conditional notion, like focus, does not function as a grammatical case assigner (see (9b), Kim (2004b) and Kim et al. (2007)).

There are two other approaches to case marking in Korean: default nominative assignment hypothesis (Kang (1986) and Kim (2008), among others) and direct case marking hypothesis (Maling & Kim (1992, 39)). The former claims that, while an NP argument which is a sister of [–stative] V<sup>0</sup> is assigned accusative case (Kang (1986)), a nominative case in Korean is not assigned by any element. According to this claim, the nominative case marking takes place by default when an NP lacks a case Kim (2008, 115). The latter approach says that the part-NP is assigned case directly by V, and the whole-NP is assigned case either by V or by INFL, depending on its surface position (Maling & Kim (1992: 39)).

These two approaches, which have been proposed in the context of transformational grammars, seem to describe the case marking pattern of some double nominative constructions. But they have difficulties in dealing with the multiple nominative constructions (20), where more than two NPs are marked with nominative, and the multiple accusative constructions (21).

- (20)  $[_{NP_2}$  thokki-ka]  $[_{NP_1}$  kuy-ka]  $[_{NP_1}$  ttuth-i] ppocokha-ta.  
 rabbit-NOM ear-NOM top-NOM be.pointed-DECL  
 ‘The top of ears of rabbits is pointed.’

- (21) Mary-ka John-ul tali-lul cha-ass-ta.  
 Mary-NOM John-ACC leg-ACC kick-PAST-DECL  
 ‘Mary kicked the leg of John.’

We propose that grammatical cases are assigned by grammatical rules. We assume the following two grammatical rules for nominative case marking and accusative case marking, respectively.

- (22) Head-Subject Rule

$$[hd-subj-phrase] \rightarrow \boxed{1} \left[ \text{CASE} \left[ \text{GCASE } nom \right] \right] \quad \mathbf{H} \left[ \begin{array}{l} \text{SUBJ} \langle \boxed{1}, \dots \rangle \\ \text{COMPS} \langle \rangle \end{array} \right]$$

- (23) Head-Complement Rule

$$[hd-comp-ph] \rightarrow \boxed{1} \left[ \text{CASE} \left[ \text{GCASE } acc \right] \right] \quad \mathbf{H} \left[ \begin{array}{l} \text{HEAD} | \text{AGT} + \\ \text{COMPS} \langle \boxed{1}, \dots \rangle \end{array} \right]$$

To account for multiple case marking, we propose the following two constraints: SUBJ-DEPS composition constraint (for NOM-NOM sequences) and COMPS-DEPS composition constraint (for ACC-ACC sequences).

- (24) SUBJ-DEPS composition constraint (for NOM-NOM sequences)

$$verb \Rightarrow \left[ \begin{array}{l} \text{VAL} | \text{SUBJ} \langle \left[ \text{DEPS} \langle \boxed{1} \rangle \right]_j \rangle \oplus \langle \boxed{1} \ i \rangle \\ \text{SEM} | \text{RELS} \left\langle \dots, \left[ \begin{array}{l} \text{RELN} \text{ } conceptual \ linking \\ \text{ARG1} \ i \\ \text{ARG2} \ j \end{array} \right], \dots \right\rangle \end{array} \right]$$

(25) COMPS-DEPS composition constraint (for ACC-ACC sequences)

$$verb \Rightarrow \left[ \begin{array}{l} VAL | COMPS \langle [DEPS \langle [2] \rangle]_j, \dots \rangle \oplus \langle [2]_i \rangle \\ SEM | RELS \left\langle \dots, \left[ \begin{array}{ll} RELN & \textit{intrinsic relation} \\ ARG1 & i \\ ARG2 & j \end{array} \right], \dots \right\rangle \end{array} \right]$$

The SUBJ-DEPS composition constraint (24) declares that any DEPS value of the subject argument, if any, which satisfies the *conceptual linking* constraints, is appended to the list of the SUBJ feature. This constraint ensures that the subject argument and all its dependents are specified in the list value of the SUBJ feature. They are all assigned nominative case, since according to Head-Subject Rule (22) all elements in the list value of the SUBJ feature are realized in nominative case.

The COMPS-DEPS composition constraint (25) declares that any DEPS value of the direct object argument, if any, which satisfies the *intrinsic relation* constraints, is appended to the list of the COMPS feature. This constraint ensures that the direct object argument and all its dependents are specified in the list value of the COMPS feature. They are all assigned accusative case, since according to Head-Complement Rule (23) all elements in the list value of the COMPS feature are realized in accusative case.

One further constraint we need is DEPS composition (26), which ensures that, when a nominal head has a value of the DEPS feature, it inherits the value of the DEPS feature. The basic idea of this constraint comes from the argument composition mechanism.

(26) DEPS composition

$$noun \rightarrow \left[ DEPS \langle [DEPS \square] \rangle \oplus \square \right]$$

Now, with the constraints in (24) and (25), all the adjuncts share the same case marker with the head of the sequence, i.e. the right-most NP of the sequence. They are marked with nominative case, if they satisfy one of the 16 types subsumed by *conceptual linking* and the right-most NP of the sequence is marked with nominative case. They are marked with accusative case, if they satisfy one of the 10 types subsumed by *intrinsic relation* and the right-most NP of the sequence is marked with accusative case. The sequence of NPs standing in one of the 6 *extrinsic relations* may occur exclusively in multiple nominative constructions.

## 8 Illustrations and Predictions

To illustrate how the proposal made here works, let us examine a simplified tree of the sentence (1). In this example, two NPs are marked with nominative case, and three NPs with accusative case. The class-membership relation, which is a requirement for nominative case marking, holds between  $\boxed{4}$ NP and  $\boxed{4}$ NP. The nominative case marker is shared between the two NPs, since  $\boxed{4}$ NP is marked with a nominative case. The integral object-component relation, which is a requirement

for accusative case marking, holds between [1]NP, [2]NP and [3]NP. The accusative case marker is shared between these three NPs, since [1]NP is marked with an accusative case.

(27) A simplified tree of the sentence (2)

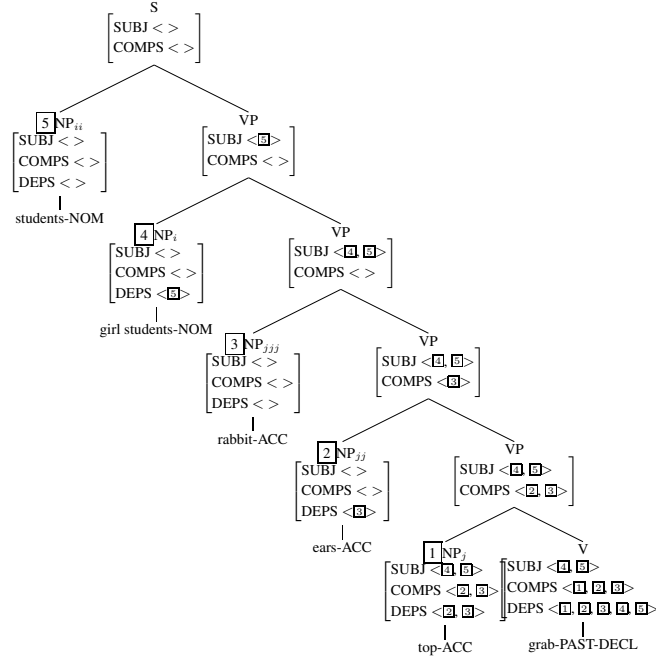

The semantic representation of the whole sentence is regulated by Semantic Inheritance Principle (Sag et al. (2003)), which states that in any well-formed phrase structure, the mother's RELS value is the sum of the RELS values of the daughters.

(28) The relevant semantic representation of S (*iop* = *integral object-comp.*, *cm* = *class-membership*)

$$\left[ \text{SEM} \mid \text{RELS} \left\langle \left[ \begin{array}{l} \text{RELN } grab \\ \text{ARG1 } i \\ \text{ARG2 } j \end{array} \right], \left[ \begin{array}{l} \text{RELN } cm \\ \text{ARG1 } i \\ \text{ARG2 } ii \end{array} \right], \left[ \begin{array}{l} \text{RELN } iop \\ \text{ARG1 } j \\ \text{ARG2 } jj \end{array} \right], \left[ \begin{array}{l} \text{RELN } iop \\ \text{ARG1 } jj \\ \text{ARG2 } jjj \end{array} \right], \right\rangle \right]$$

Some appealing consequences of this proposal include a new comprehensive classification of the sequences of same-case NPs and a straightforward account of some long standing problems such as how the additional same-case NPs are licensed, and in what respects the multiple nominative marking and the multiple accusative marking are alike and different from each other. The ungrammaticality of the sentence (29b) can be accounted for in our analysis, since the relation *space-object* is not a subtype of *intrinsic relation*, which is a requirement for accusative case marking in our proposal.

(29) a. ku haypyen-i miin-tul-i katukha-ta.  
that beach-NOM sexy girl-PL-NOM be.crowded-DECL

‘The beach is crowded with sexy girls.’ (Type 11 Space-object)

- b. \*na-nun ku haypyen-**ul** miin-tul-**ul** cohaha-n-ta.  
I-TOP that beach-ACC sexy girl-PL-ACC like-PRES-DECL

Note that passive converts the multiple accusative sentences into multiple nominative sentences. This case conversion can be also explained in our account, if we assume that NP<sub>2</sub> is in the COMPS list in (30) and in the SUBJ list in (31), respectively.

- (30) John-i [<sub>NP<sub>1</sub></sub> thokki-lul/\*ka] [<sub>NP<sub>2</sub></sub> kuy-lul/\*ka] cap-ess-ta. (active)  
John-NOM rabbit-ACC/\*NOM ear-ACC/\*NOM grab-PAST-DECL  
‘John grabbed the ears of rabbits.’

- (31) [<sub>NP<sub>1</sub></sub> thokki-ka/\*lul] [<sub>NP<sub>2</sub></sub> kuy-ka/\*lul] John-eykey cap-hi-ess-ta. (passive)  
rabbit-NOM/\*ACC ear-NOM/\*ACC John-BY grab-PASS-PAST-DECL  
‘The ears of rabbits were grabbed by John.’

## 9 Conclusion

This paper presents a unified approach to multiple nominative and accusative constructions in Korean. We identify 16 semantic relations holding between two consecutive NPs in multiple case marking constructions, and propose each semantic relation as a licensing condition on double case marking. We argue that the multiple case marking constructions are merely the sequences of double case marking, which are formed by dextrosinistrally sequencing the pairs of the same-case marked NPs of same or different type. We show that, while the nominative case marker is shared between two consecutive NPs standing in one of the 16 semantic relations, multiplication of the accusative case marker is possible between two consecutive NPs standing in only one of the 10 semantic relations.

Some minor findings made in this paper are as follows: (i) only the rightmost NP is subject or object, and all the other additional NPs are adjuncts, (ii) the additional NPs are case-marked via case sharing between the two consecutive NPs, (iii) the additional NPs may optionally be a focus, but it may not assign a case, and (iv) the licensing condition for the additional NPs is *conceptual linking*, and (v) multiple case marking is not confined to the stative verbs.

Some appealing consequences of this proposal’s findings include a new comprehensive classification of the sequences of same-case NPs and a straightforward account of some long standing problems such as how the additional same-case NPs are licensed, and in what respects the multiple nominative marking and the multiple accusative marking are alike and different from each other. Importantly, we showed that this new insight enables us to solve many previously unresolved questions without invoking any further *ad hoc* assumptions.

## References

- Bouma, Gosse, Rob Malouf & Ivan Sag. 2001. Satisfying Constraints on Extraction and Adjunction. *Natural Language and Linguistic Theory* 19. 1–65.
- Cha, Jong-Yul. 2008. A Typology of Double Nominative Constructions in Korean. In *Proceedings of 18th International Congress of Linguists (SIL XIII)*, Seoul.
- Chae, Hee-Rahk & Ilkyu Kim. 2008. A Clausal Predicate Analysis of Korean Multiple Nominative Constructions. *Korean Journal of Linguistics* 33. 869–900.
- Choi, Incheol. 2012. Sentential Specifiers in the Korean Clause Structure. In Stefan Müller (ed.), *Proceedings of the 19th International Conference on Head-Driven Phrase Structure Grammar*, 75–85. Stanford: CSLI Publications.
- Choi, Kiyong. 2008. Two Types of Double Nominative Constructions in Korean: A Case of GEN/NOM Alternation (written in Korean). *Korean Journal of Linguistics* 33. 901–928.
- Cruse, D.A. 1986. *Lexical Semantics*. Cambridge: Cambridge University Press.
- Hong, Yong-Tcheol. 2001. Structure des Constructions à Sujet Multiple (written in Korean). *Enseignement de Langue et Littérature Françaises* 11. 159–183.
- Iris, Madelyn, Bonnie Litowitz & Martha Evens. 1988. Problems of the Part-Whole Relation. In M. Evens (ed.), *Relational Models of the Lexicon*, 261–288. Cambridge: Cambridge University Press.
- Kang, Young-Se. 1986. *Korean Syntax and Universal Grammar*. Cambridge, MA: Harvard University dissertation.
- Kim, Jong-Bok. 2001. A Constraint-based and Head-driven Analysis of Multiple Nominative Constructions. In Dan Flickinger & Andreas Kathol (eds.), *Proceedings of the 7th International Conference on Head-Driven Phrase Structure Grammar*, 166–181. Stanford: CSLI Publications.
- Kim, Jong-Bok. 2004a. A Constraint-Based Approach to Some Multiple Nominative Constructions in Korean. In Akira Ikeya & Masahito Kawamori (eds.), *Proceedings of the 14th Pacific Asia Conference on Language, Information, and Computation*, 165–176. Toyko: Logico-Linguistic Society of Japan, The Institute of Language Teaching, and Waseda University Media Network.
- Kim, Jong-Bok. 2004b. *Hankwuke Kwukwuco Mwonpep (written in Korean, Korean phrase structure grammar)*. Seoul: Hankuk Munhwasa.
- Kim, Jong-Bok, Peter Sells & Jaehyung Yang. 2007. Parsing Two Types of Multiple Nominative Construction: A Constructional Approach. *Language and Information* 11. 25–37.



- Kim, Young-joo. 2008. Nominative Case Marking in Korean. *Studies in Generative Grammar* 2. 113–148.
- Lee, Seong-yong. 1997. Two Subject Positions in Multiple Nominative Constructions. *Journal of Language Sciences* 14. 239–262.
- Maling, Joan & Soowon Kim. 1992. Case Assignment in the Inalienable Possession Constructions in Korean. *Journal of East Asian Linguistics* 1. 37–68.
- Na, Younghee & Geoffrey Huck. 1993. On the Status of Certain Island Violations in Korean. *Linguistics and Philosophy* 16. 181–229.
- Park, Byung-Soo. 2001. Constraints on Multiple Nominative Constructions in Korean: A Constraint-based Lexicalist Approach. *The Journal of Linguistic Science* 20. 147–190.
- Rhee, Seongha. 1999. On the Multiple Nominative Constructions in Korean. In Young-Wha Kim, Il-Kon Kim & Jeong-Woon Park (eds.), *Linguistic Investigations: In Honor of Professor In-Seok Yang*, 198–430. Seoul: Hankuk Publisher.
- Ryu, Byong-Rae. 1993. Structure Sharing and Argument Transfer: An HPSG Approach to Verbal Noun Constructions. SfS-Report 04-93 Seminar für Sprachwissenschaft Universität Tübingen.
- Ryu, Byong-Rae. 2013. Semantic Constraints on Multiple Case Marking in Korean. Ms., Chungnam National University.
- Sag, Ivan, Thomas Wasow & Emily Bender. 2003. *Syntactic Theory: A Formal Introduction, 2nd Edition*,. Stanford: CSLI Publications.
- Schütze, Carson T. 2001. On Korean “Case Stacking”: The Varied Functions of the Particles *ka* and *lul*. *The Linguistic Review* 18. 193–232.
- Winston, Morton E., Roger Chaffin & Douglas Hermann. 1987. A Taxonomy of Part-whole Relations. *Cognitive Science* 11. 417–444.
- Yang, In-Seok. 1972. *Korean Syntax: Case Markers, Delimiters, Complementation and Relativization*. Hawaii: The University of Hawaii dissertation.
- Yoon, James H. 1986. Some Queries Concerning the Syntax of Multiple Subject Constructions in Korean. *Studies in the Linguistic Sciences* 16. 215–236.
- Yoon, James H. 2007. The Distribution of Subject Properties in Multiple Subject Constructions. In Y. Takubo, T. Kinuhata, S. Grzelak & K. Nagai (eds.), *Japanese/Korean Linguistics 16*, 64–83. Stanford.
- Yu, Kil-chun. 1909. *Tayhanmwuncen (Korean Grammar, written in Korean)*. Hansung: Yungmwunkwan.

# Argument inheritance and left periphery in Hungarian infinitival constructions

Tibor Szécsényi 

University of Szeged, Hungary

Proceedings of the 20th International Conference on  
Head-Driven Phrase Structure Grammar

Freie Universität Berlin

Stefan Müller (Editor)

2013

Stanford, CA: CSLI Publications

pages 203–221

Szécsényi, Tibor. 2013. Argument inheritance and left periphery in Hungarian infinitival constructions. In Stefan Müller (ed.), *Proceedings of the 20th International Conference on Head-Driven Phrase Structure Grammar, Freie Universität Berlin*, 203–221. Stanford, CA: CSLI Publications. DOI: 10.21248/hpsg.2013.11.



## Abstract

Hungarian infinitival constructions have both mono-clausal and bi-clausal properties at the same time. The arguments of the infinitive behave the same way as the arguments of the finite verb do, but the non-finite verb has its own left periphery. After discussing the general description of Hungarian sentence structure and presenting an HPSG analysis for it – including a description of the connection between word order and scope order in the Hungarian left periphery – this paper presents an analysis for Hungarian infinitival constructions. The analysis lexically distinguishes the left peripheral arguments of the infinitive from its complements, and allows the infinitive and its left peripheral arguments to form constituents, while the complements of the infinitive are inherited to the finite verb.

### 1 The Hungarian sentence structure\*

Hungarian is said to be a free word order language. The position of the constituents does not depend on their syntactic function. As shown in example (1), postverbal word-order is totally free.<sup>1</sup>

- (1) a. Fel-hívta Péter tegnap Marit.  
VM-called Peter.NOM yesterday Mari.ACC  
'Peter called Mari yesterday.'
- b. Fel-hívta Marit Péter tegnap.
- c. Fel-hívta tegnap Péter Marit.

On the other hand, the arguments of the verb may not be in postverbal positions only. They can appear in preverbal position too, but in that case they have a special interpretation and function. For detailed discussion see (É. Kiss 1987, 2002).

#### 1.1 Topicalisation

This special function can be, among others, the topic function. Any referential constituent can occur in the preverbal position, whether it is the subject, the object or some non-obligatory argument.

- (2) a. **Péter** fel-hívta tegnap Marit.  
'As for Peter, he called Mari yesterday.'

---

\* The research presented here is supported by the Hungarian Scientific Research Fund (OTKA NK 100804).

<sup>1</sup> VM means verbal modifier. Verbal modifiers form a complex predicate with the verb, in these examples it makes the verb perfective. Verbal complexes form a phonological unit with the verb in neutral sentences, but in non-neutral sentences verbal modifiers are in postverbal position too.

- b. **Marit** fel-hívta Péter tegnap.  
'As for Mari, Peter called her yesterday.'
- c. **Tegnap** fel-hívta Péter Marit.  
'As for yesterday, Peter called Mari.'

More than one constituent can be topicalised, as you can see in (3). But only referential constituents can be topicalised, non-referentials, such as universal quantifiers, cannot.

- (3) Tegnap Péter fel-hívta Marit.
- (4) \***Mindenki** Marit fel-hívta tegnap.  
everybody.NOM Mary.ACC VM-called yesterday  
(*everybody* precedes the topicalised *Marit*.)

### 1.2 Focussing

Another preverbal position is the focus position. The verb may be immediately preceded by a phonologically emphatic constituent, the focus.

- (5) a. **PÉTER** hívta fel Marit tegnap.  
Peter.NOM called VM Mari.ACC yesterday  
'It was Peter who called Mari yesterday.'
- b. **MARIT** hívta fel Péter tegnap.  
'It was Mari that Peter called yesterday.'
- c. Péter **MARIT** hívta fel tegnap.  
'As for Peter, it was Mari that he called yesterday.'
- d. Marit **TEGNAP** hívta fel Péter.  
'As for Mari, it was yesterday that Peter called her.'

The focussed constituent may be subject, object, or any argument. In these sentences, the verbal modifier cannot be in preverbal position, it must appear after the verb. The topic and focus position can be filled at the same time, in this case the topic constituent must precede the focus constituent.

Some expressions are obligatorily focussed: *csak*-phrases, question-words, etc.

- (6) a. Tegnap **CSAK PÉTER** hívta fel Marit.  
yesterday only Peter.NOM call VM Mari.ACC  
'It was only Peter who called Mari yesterday.'
- a' \*Tegnap hívta fel/felhívta CSAK PÉTER Marit.
- b. Tegnap **KI** hívta fel Marit?  
yesterday who called VM Mary.ACC  
'Who called Mary yesterday?'
- b'. \*Tegnap hívta fel/felhívta KI Marit?

- c. Tegnap **KEVESEN** hívták fel Marit.  
 yesterday few called VM Mari.ACC  
 ‘Few people called Mari yesterday.’

c'. \*Tegnap hívták fel/felhívták **KEVESEN** Marit

In contrast to the topic position, only one constituent can be in the preverbal focus position.

- (7) \*CSAK PÉTER CSAK MARIT hívta fel tegnap.

It is possible for a sentence to contain two focussed constituents, but in this case only one of them can appear in the preverbal focus position, the second focus position is after the verb. This postverbal focus position is present only if the preverbal focus position is filled by a focussed constituent.

- (8) PÉTER hívta fel tegnap **CSAK MARIT**.  
 Peter.NOM called VM yesterday only Mari.ACC  
 ‘It was Peter who called only Mari yesterday.’

Some constituents, such as universal quantifiers cannot be focussed.

- (9) \*Marit **MINDENKI** hívta fel tegnap.  
 Mari.ACC everybody.NOM called VM yesterday

### 1.3 Quantifier field

The third preverbal position is the so called quantifier field. Expressions containing a distributive quantifier may stay after the verb (10a) or optionally appear in preverbal position (10b). If there are more quantifiers in the sentence, all of them can be in preverbal positions (10c). This preverbal quantifier field is between the topic and focus positions (10d).

- (10) a. Marit meg-látogatta tavaly **mindenki**.  
 Mari.ACC VM-visited in.the.last.year everybody.NOM  
 ‘Everybody visited Mari in the last year.’
- b. Marit **mindenki** meg-látogatta tavaly **többször is**.  
 Mari.ACC everybody.NOM VM-visited in.the.last.year several.times  
 ‘Everybody visited Mari several times in the last year.’
- c. Marit **mindenki többször is** meglátogatta tavaly.
- d. Marit **többször is** CSAK PÉTER látogatta meg tavaly.  
 Mari.ACC several.times only Peter visited VM in.the.last.year  
 ‘As for Mari, it was only Peter who visited Mary several times in the last year.’

### 1.4 Word order in the Left periphery

Hungarian word order is free in the sense that there is no preferred position for the subject and the object of the sentence. The constituents can be scrambled in postverbal positions only, in the left periphery it is different: the

number and order of constituents in the left periphery is defined by their functions: zero or more referential expressions (=Topic) are followed by zero or more distributive quantifiers (=Quantifier) that can be followed by a Focus constituent, which immediately precedes the verb:

(11) Topic\* - Quantifier\* - (Focus) - Verb

Furthermore, constituent order in the preverbal position is the same as their scopal order (c.f. Szabolcsi 1997): a quantified constituent preceding another takes scope over it:

- (12) a. Marit **mindenki** **többször is** meg-látogatta tavaly.  
 Mari.ACC everybody.NOM several.times VM-visited last.year  
 ‘Everybody visited Mari several times last year.’  
 everybody >> several times
- b. Marit **többször is mindenki** meglátogatta tavaly.  
 several times >> everybody

In (12a) the universal quantifier *mindenki* has scope over the non-obligatory *többször is*, so the meaning of the sentence is that ‘everybody is so that she visited Mari several times in the last year’, while the meaning of the sentence (12b) is that ‘it happened several times in the last year that everybody visited Mari.’

On the other hand, this correlation of word order and scope is true only for the constituents of the left periphery. If a quantifier remains in postverbal position it can have narrow or wide scope.

- (13) Marit **többször is** meglátogatta tavaly **mindenki**.  
 everybody >> several times OR  
 several times >> everybody

The rule for the constituents of the left periphery is that their scope must not be wider than the scope of constituents preceding them.

The correlation of word order and scope is observable for all preverbal constituents:

- (14) a. Marit **többször is CSAK PÉTER** látogatta meg tavaly.  
 Mari.ACC several.times only Peter visited VM in.the.last.year  
 ‘It occurs several times that Mari was visited by Peter only in the last year.’
- b. Marit **CSAK PÉTER** látogatta meg **többször is** tavaly.  
 ‘It was only Peter who visited Mari several times in the last year.’

Since the position of the focussed constituent is fixed, it can scope over another constituent only if it is in postverbal position.

## 2 The analysis of Hungarian sentence structure

### 2.1 Constituent structure

In a transformational analysis (c.f. É. Kiss 1987, 2002), the constituent structure of the sentence consists of a flat VP and a hierarchical left periphery. In the deep structure all the constituents are under the VP, and later the topic, the quantifier and the focus move up their respective functional positions.

In my HPSG analysis for Hungarian I used a similar sentence structure (Szécsényi 2009, 2011). The verb and the postverbal constituents form a flat head-complement structure, and the different constituents of the left periphery form a filler head construction.

(15)

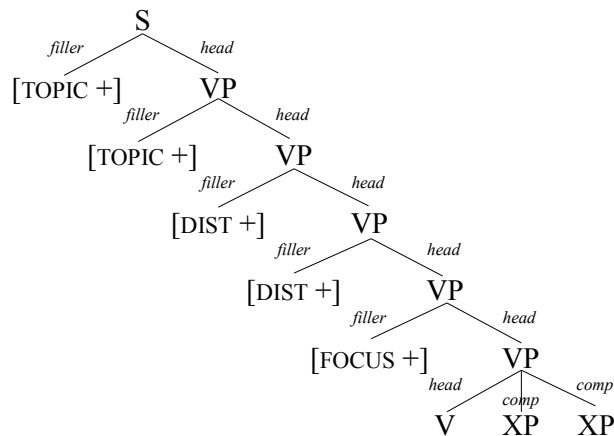

The head-complement schema in (16) that licences the flat postverbal structure is different from the other head-complement schemata in the language. Since the word order is free only in the sentential level, other phrases match the standard X-bar rules:

(16) Head-Complement Schema

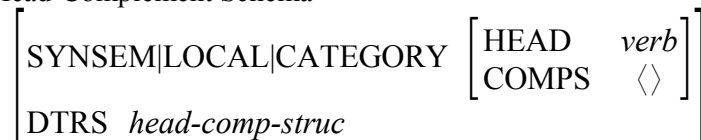

This schema licences a verb-headed construction where all of the head's complements are present in the constituent, so the mother's head feature is of the *verb* type, and the mother's comps list is empty.

Since almost any of the constituents can appear on the left periphery of the sentence, they must be moved from the COMPS-list of the verb into the verb's SLASH set with the help of lexical rules. The standard *complement extraction lexical rule* (17) does this: it picks out an element from the complements of the verb.

(17) Complement Extraction Lexical Rule (Pollard and Sag 1994:378)

$$\left[ \begin{array}{l} \text{DEPS} \langle \dots, \boxed{3}, \dots \rangle \\ \text{COMPS} \langle \dots, \boxed{3}[\text{LOC } \boxed{1}], \dots \rangle \\ \text{INHER|SLASH} \boxed{2} \end{array} \right]$$

↓

$$\left[ \begin{array}{l} \text{DEPS} \langle \dots, \boxed{4} \left[ \begin{array}{l} \text{LOC } \boxed{1} \\ \text{NONLOC|INHER|SLASH } \{ \boxed{1} \} \end{array} \right], \dots \rangle \\ \text{COMPS} \langle \dots, \dots \rangle \\ \text{INHER|SLASH} \{ \boxed{1} \} \cup \boxed{2} \end{array} \right]$$

There are two valence features on the description of the verb's lexical description: the DEPS contains all of the arguments, the COMPS contains only those arguments which appear in postverbal position.

Since the arguments of the verb can appear in preverbal position for various reasons, for example one may function as Topic, another as Focus, we need to modify this lexical rule specifying the details of these functions. For example in the case of focusing, a special *Focus Selecting Lexical Rule* (18) grants that the interpretation of the lexical item is changed from  $\alpha$  to  $\beta$ , while one of its complements gets into the SLASH list. This rule can be used only if the original lexical item does not have a focussed constituent, so only one argument can become focussed.<sup>2</sup>

(18) Focus Selecting Lexical Rule

$$\left[ \begin{array}{l} \text{LOC} \left[ \begin{array}{l} \text{CAT} \left[ \begin{array}{l} \text{DEPS} \langle \dots, \boxed{3}, \dots \rangle \\ \text{COMPS} \langle \dots, \boxed{3}[\text{LOC } \boxed{1}], \dots \rangle \end{array} \right] \\ \text{CONTENT } \alpha \end{array} \right] \\ \text{NONLOC|INHER} \left[ \begin{array}{l} \text{SLASH } \boxed{2} \\ \text{FOCUS } \{ \} \end{array} \right] \end{array} \right]$$

↓

$$\left[ \begin{array}{l} \text{LOC} \left[ \begin{array}{l} \text{CAT} \left[ \begin{array}{l} \text{DEPS} \langle \dots, \boxed{4} \left[ \begin{array}{l} \text{LOC } \boxed{1} \\ \text{NONLOC|INHER|SLASH } \{ \boxed{1} \} \end{array} \right], \dots \rangle \\ \text{COMPS} \langle \dots, \dots \rangle \end{array} \right] \\ \text{CONTENT } \beta \end{array} \right] \\ \text{NONLOC|INHER} \left[ \begin{array}{l} \text{SLASH } \{ \boxed{1} \} \cup \boxed{2} \\ \text{FOCUS } \{ \boxed{1} \} \end{array} \right] \end{array} \right]$$

Similar rules are responsible for topicalisation and quantifier raising.

<sup>2</sup>Of course there can be more than one focus constituent in the sentence, as it was presented in the examples in (8), but describing this phenomenon is out of the scope of the present paper. For a detailed description of multiple focus structures see Szécsényi (2011:113–116).



## 2.2 Linear order and scope in the left periphery

One problem has remained unsolved: the correlation of scope and word order in the left periphery. The HPSG quantifier storage mechanism allows a quantified constituent to have wider scope than what is indicated by its position. Quantifier storage allows the quantifiers of quantified constituents to be stored and to rise up in the sentence structure to a proper place where they are ordered based on their scope. It is useful tool in accounting for the interpretation of Hungarian postverbal constituents, but cannot be applied for preverbal ones.

In order to solve this problem quantifier retrieving and filler discharging must be synchronised. In *filler-head* constructions the QSTORE feature of the mother and the filler daughter must be disjunct. In this case the quantifier of the filler daughter doesn't rise up in the structure, so its scope is narrower than that of the higher filler daughters.

(19) Szécsényi 2005, 2009, 2011

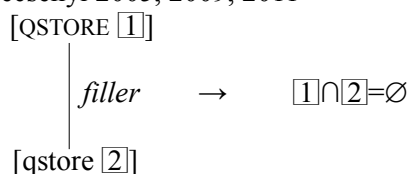

### 3 Hungarian infinitival constructions: data

Example (20) presents a neutral infinitival construction. *Péter* is the subject of both the finite verb *szeretne* 'would like', it is in topic position, and the non-finite verb, *beszélni* 'to talk', and its arguments, *holnap* 'tomorrow' and *Marival* 'with Mari' are after the matrix verb.

(20) Péter szeretne holnap beszélni Marival.  
 Peter.NOM would.like tomorrow talk.INF Mari.WITH  
 'Peter would like to talk to Mari tomorrow.'

However, in light of the data presented here it is not clear whether the non-finite verb and its arguments form a constituent or not. The phenomenon was first observed in É. Kiss (1987, 1989).

#### 3.1 Infinitival constructions are simple sentences

Our first observation is that it is not only the arguments of the finite verb that can appear on the left periphery of the sentence, namely before the finite verb itself, but the arguments of infinitive can do so as well. In (21) the obligatory arguments of the infinitive appear in topic position (21a), quantifier position (21b) or focus position (21c). These data suggest that the finite verb handles the arguments of the infinitive the same way as it does its own arguments: they can be topicalised, focussed, and they can rise up to quantifier position.

- (21) a. **Marival** Péter szeretne holnap beszélni.  
 Mari.WITH Peter.NOM would.like tomorrow talk.INF  
 ‘As for Mari, Peter would like to talk to her tomorrow.’
- b. Péter **mindenkivel** szeretne holnap beszélni.  
 Peter.NOM everybody.WITH would like tomorrow talk.INF  
 ‘Peter would like to talk to everybody tomorrow.’
- c. Péter **CSAK MARIVAL** szeretne holnap beszélni  
 Peter.NOM only Mari.WITH would.like tomorrow talk.INF  
 ‘It is only Mary whom Peter would like to talk to tomorrow.’

Furthermore, it is not only the obligatory arguments of the infinitive that behave like this, but also its non-obligatory arguments, and even the infinitive itself. Since the infinitive cannot be referential or quantified, it can only be focussed:

- (22) a. Péter **HOLNAP** szeretne Marival beszélni.  
 ‘Peter would like to talk to Mari TOMORROW.’
- b. Péter **BESZÉLNI** szeretne holnap Marival.  
 ‘Peter would like to TALK to Mari tomorrow.’

These data suggest that the infinitive and its arguments do not form one constituent in the sentence, the infinitive is not a clause.

Other data support this analysis. The sentences in (23) show that when the finite verb's argument of its own, the subject, occurs in postverbal position, it can be between the infinitive and one of its arguments.

- (23) a. Holnap szeretne **Péter** beszélni Marival.  
 tomorrow would.like Peter.NOM talk.INF Mari.WITH  
 ‘Peter would like to talk to Mary tomorrow.’
- b. Holnap szeretne beszélni **Péter** Marival.
- c. Holnap szeretne beszélni Marival **Péter**.
- d. Holnap szeretne **Péter** Marival beszélni.
- e. Holnap szeretne Marival **Péter** beszélni.
- f. Holnap szeretne Marival beszélni **Péter**.

Since the subject of the finite verb is the subject of the infinitive as well, these facts may not be regarded problematic. But if we look at sentence (24), we can see that it is not only the subject that can scramble into the infinitival construction, but other arguments of the finite verb can do so, too. In the sentence in (24) it is the non obligatory argument of the verb.

- (24) PÉTER akarta át-úszni **tavaly** a folyót.  
 Peter.NOM wanted across-swim.INF in.the.last.year the river.ACC  
 ‘Peter wanted to swim across the river in the last year.’

These data indicate that the arguments of the finite and non-finite verb are in the same domain: the non-finite verb and its arguments do not form a constituent.

### 3.2 Infinitival constructions are bi-clausal

On the other hand there is a phenomenon that indicates that there is a constituent which contains the infinitive and its arguments. In sentence (25) there are three constituents preceding the infinitive that can be argued to target positions in the left periphery of the infinitive:

- (25) Péter szeretne Marival mindennap CSAK EBÉD ELŐTT beszélni.  
 Peter.NOM would.like Mari.WITH every.day only lunch before talk.INF  
 ‘Only before lunch is the time when Peter would like to talk with Mari every day.’

The constituent *Marival* ‘with Mari’ is in topic position, *mindennap* ‘every day’ is in quantifier position, and *csak ebéd előtt* ‘only before lunch’ is in focus position, exactly in the order required in the left periphery of a simple sentence. And since these positions are characterised as typical sentential positions, we should analyse infinitival constructions as subordinated clauses. But the question arises whether these constituents are really in those positions. The following problems emerge:

a) There is no explicit sign that a constituent is a topic except its position: *Marival* can be either in the topic position of the infinitive, or it can be a postverbal constituent of the finite verb.

b) Quantified constituents can be either in preverbal or in postverbal position (as seen in (10)). Is *mindennap* ‘every day’ in preverbal position (with respect to the non-finite verb), or postverbal position? The only difference between the two positions is in their scope interpretation: a postverbal quantifier can have both narrow or wide scope, a preverbal quantifier cannot, it has to have wide scope. In (26), the quantified object of the infinitive appearing in different positions has different scope with respect to the finite verb. In sentence (26b) it has wide scope as predicted by our earlier observations, but in sentence (26a) the quantified constituent has narrow scope only, which unexpected based on the fact that it appears in postverbal position, at least with respect to the finite verb. However, it is possible to account for the narrow interpretation if we assume that the quantified expression is not in postverbal position but in *preinfinitival* position. If the quantified object appears after the infinitive (26c), its scope is underspecified.

- (26) a. Péter fél mindent meg-kérdezni.  
 Peter.NOM afraid everything.ACC VM-asked  
 ‘Peter is afraid to ask everything.’  
 afraid of >> everything
- b. Péter mindent fél megkérdezni.  
 ‘Peter is afraid to ask anything.’  
 everything >> afraid of
- c. Péter fél megkérdezni mindent.  
 ‘Peter is afraid to ask everything.’ OR  
 ‘Peter is afraid to ask anything.’  
 everything >> afraid of OR  
 afraid of >> everything

c) Although the position of the focus is typically on the left side of the verb, in the case of a multiple focus construction the second focus can be in postverbal position (cf. (7) and (8)). A focussed constituent followed by a non-finite verb can be second focus as well. So the focus constituent in sentence (25) may be after the finite verb, not in the focus position associated with the infinitive.

There is an obvious way to make sure that it is the only focussed constituent in the sentence, and, as such, cannot belong to the finite verb (remember that a post-verbal focus is possible only if a pre-verbal focus is also present in the sentence). In example (9) we saw that universally quantified constituents cannot be focussed. If we insert a universally quantified constituent before the finite verb, and if the sentence is still grammatical, the focus after the finite verb must be in the left periphery of the infinitive.

- (27) Mindenki szeretne CSAK MARIVAL beszélni.  
 everybody.NOM would.like only Mary.WITH talk.INF  
 ‘Everybody would like to speak with Mari only.’

To sum up the properties of infinitival constructions we have made two observations: (i) an infinitive does not form a constituent with its complements, they behave as if they were arguments of the finite verb, so, based on this, the infinitival construction should be analysed as a simple sentence; (ii) the infinitive has its own left periphery, so the infinitive forms a constituent with its left peripheral arguments, so it is an embedded clause in the matrix sentence. This means that the infinitival constructions must be analysed as bi-clausal.

In the transformational literature there are explanations offered for this phenomenon, but they are problematic. É. Kiss (1987, 1989) uses two different sentence structures, one explaining the simple sentence features, the other accounting for the bi-clausal features, but some structures do not fit into either of the patterns.

According to Szécsényi K. (2009) there is a compound sentence structure at first, and then the non-finite clause is reanalysed, so that the constituents of the non-finite sentence appear as the sisters of the finite verb, but this analysis doesn't account for the relative unity of the left periphery of the infinitive.

These analyses cannot explain all the features of Hungarian infinitival constructions.

#### 4 The analysis of infinitival constructions in HPSG

The analysis of Hungarian infinitival constructions is based on the clause union introduced by Fauconnier (1983) and Gibson and Raposo (1986). In HPSG it was used for complex predicate formation by Hinrichs and Nakazawa (1990), Kathol (1994), and Bouma (2003).

As we saw earlier, an argument of the infinitive either appears in the left periphery of the infinitive, or behaves as if it were an argument of the finite verb. First, we have to separate these kinds of arguments, the left peripheral arguments and the inherited arguments. The lexical rules seen in (17) and (18) do exactly this separation: they pick up the left peripheral arguments from the COMPS list of the verb, and put them into the SLASH set. So what happens in the infinitival construction as a result is that the infinitive builds *head-filler* structures with its left peripheral constituents, without building *head-complementiser* structures at the same time with the constituents being on its own COMPS list.

Sentence (28) illustrates the mechanism described above.

- (28) Péter szeretne CSAK EGY DALT el-énekelni mindenkinek.  
Peter.NOM would.like only one song.ACC VM-sing.INF everybody.DAT  
'Peter would like to sing only one song for everybody.'

In this sentence the control verb *szeretne* 'would like' has a subject and an infinitival complement. The infinitive has a controlled subject, an object with a focus feature (*csak egy dalt* 'only one song') and a dative argument (*mindenkinek* 'for everybody'). The subject is in the topic position of the left periphery of the finite sentence, the object is in preinfinitival focus position, and the dative constituent follows the infinitive.

The Focus Selecting Lexical Rule is applied on the infinitive verb *énekelni* 'to sing'. This rule deletes the object from the COMPS list, and puts it into the SLASH set, marking it as focus. The subject does not appear on the COMPS list of the infinitive exactly because it is an infinitive.

(29)

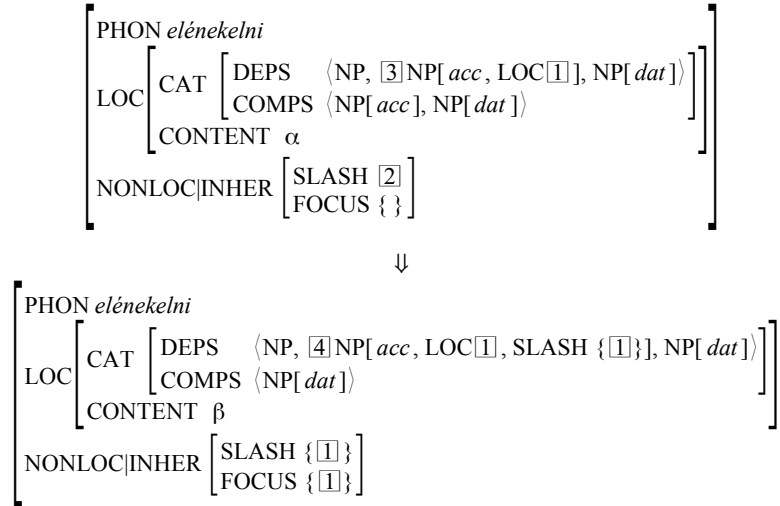

Based on the analysis in the previous section, the control verb inherits all of the complements of its infinitival arguments, except the ones located on the left periphery of the infinitive. Because the infinitival argument can have its own left periphery, its SLASH feature must be empty. The COMPS list of the infinitival argument doesn't have to be empty, its complements are inherited by the finite verb:

(30) Complete argument inheritance (control verb)

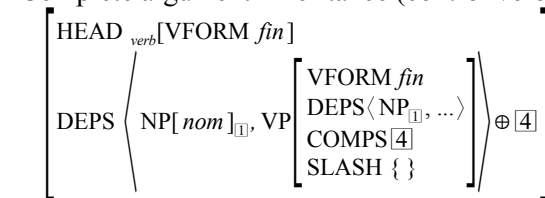

The DEPS list of the finite verb *szeretne* 'would like' contains its subject which is coindexed with the subject of the infinitive, an infinitival expression, and it is linked to the COMPS list of the infinitive. The elements of this DEPS list may be topicalised or focussed, so the COMPS list of the verb may not contain these elements.

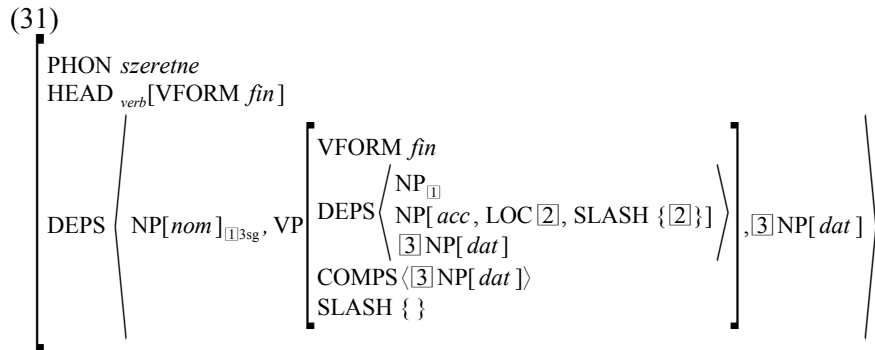

With these lexical descriptions the problem is almost solved. The last task is to ensure that a non-finite verb can form a *filler-head* construction without emptying its COMPS list. The *filler-head* schema must be extended: the COMPS list must be empty in *filler-head* constructions only for the *fin* VFORM feature. The revised version of the Head-Complement Schema in (16) is the following:

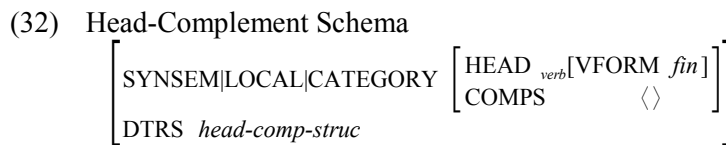

Finally, the analysis of the sentence proceeds as in (33)

(33)

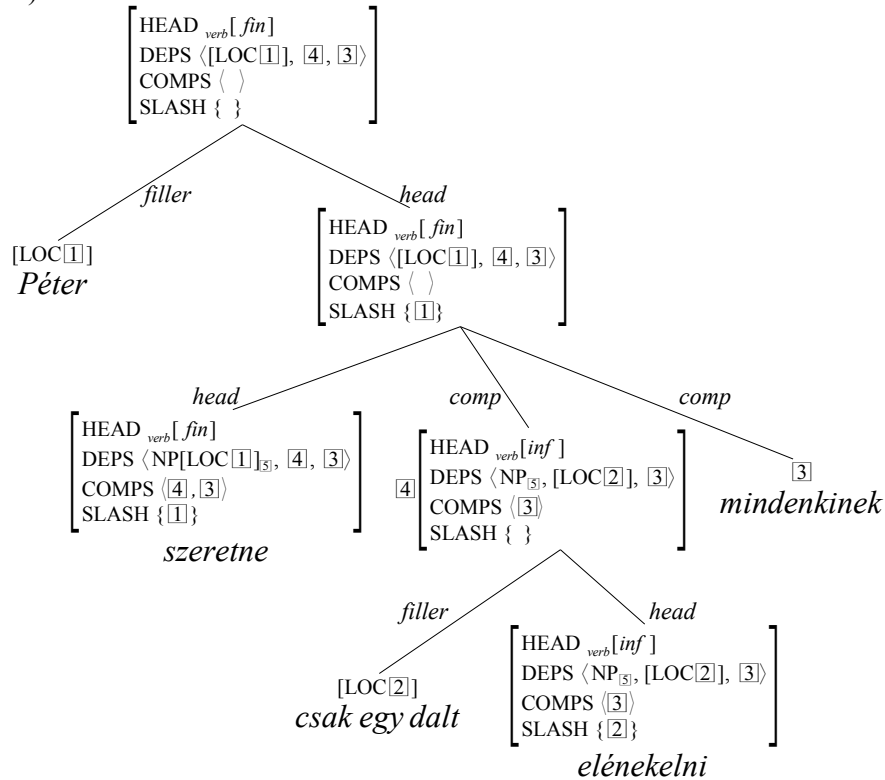

## 5 Predictions of the analysis

### 5.1 Special scope relationships

Since non-finite verbs do not have complement sisters, quantified expressions appearing after infinitival verbs must be in the complement position of the finite verb. If a constituent is in the focus position of the non-finite verb, its scope is fixed. This analysis predicts that focussed constituents of the non-finite verb have narrower scope than quantified constituents following the infinitive (34).

- (34) Mindenki szeretné CSAK MARIT fel-hívni többször is.  
everybody.NOM would.like only Mari.ACC VM-called several.times  
'Everybody would like to call only Mari several times.'  
several times >> only Mari BUT  
\* only Mari >> several times

However, if the same constituent is in the focus position of the finite verb, post-infinitival quantified constituents can have narrower or wider scope with respect to it (35).



- (35) CSAK MARIT hívta fel Péter többször is.  
 only Mari.ACC called VM Peter.NOM several.times  
 ‘It was only Mari that Peter called her several times.’  
 several times >> only Mari OR  
 only Mari >> several times

### 5.2 Complex predicate formation

Verbal modifiers form a complex predicate with the verb. In neutral sentences they immediately precede the verb, in non-neutral sentences they are in postverbal position. This part of complex predicates is always a single word. Verbal modifiers are typically adverbial particles (e. g. *el-megy* away-go ‘going away’), nominal arguments of the verb (e. g. *iskolába jár* school.INTO go ‘go to school’), or postpositional expressions (e. g. *mellém lép* next.to.me step ‘step next to me’).

Some verbs with infinitival arguments require the verbal modifier of the infinitive to be in their own verbal modifier position in neutral sentences:

- (36) a. Péter **el**-megy.  
 Peter VM(away)-go  
 ‘Peter goes away.’  
 b. Péter **el** akar menni.  
 Peter VM(away) want go.INF  
 ‘Peter wants to go away.’

If the non-finite verb doesn’t have a verbal modifier, the infinitive itself has to appear before the finite verb:

- (37) a. Péter úszik.  
 Peter swim  
 ‘Peter swims.’  
 b. Péter **úszni** akar.  
 Peter swim.INF want  
 ‘Peter wants to swim.’

If the non-finite verb does not have a left periphery, the verb appears in the complement position of the matrix verb as a single word. The infinitive can form a complex predicate with the finite verb only in this case (as verbal modifiers do).

## 6 Further argument inheritance phenomena in Hungarian

Infinitival constructions are not the only construction where this kind of argument inheritance can be attested, though it is the most salient in this case. Argument inheritance is usually related to complex predicate formation or possessive constructions. These constructions are similar with respect to the fact that the verb’s real argument and the inherited argument do not form a constituent, but they can be in separate postverbal positions.

### 6.1 Verbal modifiers

If a verbal modifier appears in the sentence, an extra constituent can appear as well. It is not extraordinary in the case of non-compositional verbal complexes, but it can be seen in compositional cases too. This extra expression is related to the verbal modifier, but they don't form a constituent: the verbal modifier immediately precedes the finite verb, while the other constituent stays in postverbal position (or it can be topicalised, etc.).

- (38) Péter énekelt.  
Peter sang  
'Peter sang.'
- (39) a. \*Péter énekelte az éjszakát.  
Peter sang the night.ACC  
b. Péter **végig**-énekelte **az éjszakát**.  
Peter VM(to.the.end)-sang the night.ACC  
'Peter sang along the night.'
- (40) a. \*Péter énekelt az ablakon.  
Peter sang the window.ON  
b. Péter **ki**-énekelt **az ablakon**.  
Peter VM(out)-sang the window.ON  
'Peter sang out of the window.'

This phenomenon can be explained assuming that the extra constituent originates as the complement of the verbal modifier, but then is inherited by the finite verb. The case of infinitival constructions can be considered as a special case of this pattern. The only difference is that non-finite verbs can have a left periphery, common verbal modifiers cannot.

### 6.2 Possessive constructions

In Hungarian there are two types of possessive constructions. The possessor is unmarked (or nominative) in the first one (41a), dative in the second (41b). The possessed agrees with the possessor in number and person in both cases. They form a constituent, which may be in postverbal position and in the left periphery as well.

- (41) a. El-veszett [**Péter kalapja**].  
VM-lost Peter.NOM hat.GEN  
'Peter's hat has been lost.'
- b. El-veszett [**Péternek a kalapja**].  
VM-lost Peter.DAT the hat.GEN  
'Peter's hat has been lost.'

The dative possessor may be separated from the possessed, one of them can be in the left periphery (42a), or there can be another argument between them in postverbal field (42b):

- (42) a. **Péternek** el-veszett **a kalapja**.  
 Peter.DAT VM-lost the hat.GEN  
 ‘Peter’s hat has been lost.’
- b. El-veszett **Péternek** tegnap **a kalapja**.  
 VM-lost Peter.DAT yesterday the hat.GEN  
 ‘Peter’s hat was lost yesterday.’

In this case the possessor does not raise from the possessive construction to some operator position, since postverbal positions are not operator positions.

Argument inheritance in possessive constructions is different from the earlier mentioned ones, because in this case argument inheritance is not obligatory, and the residue does not form a complex predicate with the verb and occupies the usually preverbal position of the verbal modifiers.

### 6.3 Postpositional phrases

The case of postpositional phrases is a mixture of the case of verbal modifiers and possessive constructions. PPs usually form a constituent (43a, 44a), but P heads can also be verbal modifiers. In this case P and its NP argument form a possessive construction: the noun phrase is in dative case, P gets an agreement suffix. Exploiting the possibilities of possessive constructions, the possessed can be separated from the possessor, and thus the P can get to a verbal modifier position (43b, 44b).

- (43) a. Péter [**a céltábla mellé**] lőtt.  
 Peter the target.NOM next.to shoot.3SG.PAST  
 ‘Peter has shot next to the target.’
- b. Péter **mellé** lőtt **a céltáblának**.  
 Peter next.to shoot.3SG.PAST the target.DAT  
 ‘Peter has shot next to the target.’
- (44) a. Péter [**a vonat után**] futott.  
 Peter the train.NOM after run.3SG.PAST  
 ‘Peter ran after the train.’
- b. Péter **utána** futott **a vonatnak**.  
 Peter after run.3SG.PAST the train.DAT  
 ‘Peter ran after the train.’

The goal of argument inheritance is forming a verbal complex, and the tool for doing this is becoming a possessive construction.

## 7 Conclusion

This paper has presented an analysis for Hungarian infinitival constructions. According to this analysis the arguments of the non-finite verb can be either in the COMPS list of the lexical verb or within its SLASH set. The slashed arguments appear in *filler-head* constructions with the infinitive forming constituents, but the elements of the COMPS list are inherited onto the matrix verb's DEPS list. The different handling of different arguments explains the double nature of Hungarian infinitival constructions: they form a clause since they can have a left periphery, but they behave as a single clause as well.

## Bibliography

- Bouma, Gosse. 2003. Verb clusters and the scope of adjuncts in Dutch. In Seuren, Pieter A. M.; Kempen, Gerard (ed.), *Verb Constructions in German and Dutch*, 5–42. Benjamins.
- É. Kiss, Katalin. 1987. *Configurationality in Hungarian*. Akadémiai Kiadó.
- É. Kiss, Katalin. 1989. Egy főnévi igeneves szerkezetéről. *Általános Nyelvészeti Tanulmányok XVII*. 153–169.
- É. Kiss, Katalin. 2002. *The syntax of Hungarian*. Cambridge UK, New York, Cambridge University Press.
- Fauconnier, Giles. 1983. Generalized Union. *Communication and Cognition* 16, 3–37.
- Gibson, Jeanne; Raposo, Eduardo. 1986. Clause Union, the Stratal Uniqueness Law, and the Chomeur Relation. *Natural Language and Linguistic Theory* 4, 295–331.
- Hinrichs, Edward W.; Nakazawa, Tsuneko. 1990. Subcategorization and VP structure in German. In Nerbonne, John; Netter, Klaus; Pollard, Carl (ed.), *Proceedings of the Third Symposium on Germanic Linguistics*. Benjamins.
- Kathol, Andreas. 1994. Passives without lexical rules. In Nerbonne, John; Netter, Klaus; Pollard, Carl (ed.), *German in Head-Driven Phrase Structure Grammar*, 237–272. CSLI.
- Pollard, Carl; Sag, Ivan A. 1994. *Head-Driven Phrase Structure Grammar*. CSLI - University of Chicago Press.
- Szabolcsi, Anna. 1997. Strategies for scope taking. In Szabolcsi, Anna (ed.), *Ways of Scope Taking*, 109–154. Kluwer Academic Press.
- Szécsényi, Krisztina. 2009. On the double nature of Hungarian infinitival clauses. *Lingua* 119/4. 592–624.
- Szécsényi, Tibor. 2005. Sorrend és hatókör a magyarban: HPSG elemzés [Word order and scope in Hungarian: An HPSG analysis]. *Nyelvtudomány* I. 171–205.
- Szécsényi, Tibor. 2009. *Lokalitás és argumentumöröklés: A magyar infinitívuszi szerkezetek leírása HPSG keretben* [Locality and argument inheritance: Hungarian infinitival constructions in HPSG]. PhD thesis. University of Szeged, 2009.
- Szécsényi, Tibor. 2011. Magyar mondat szerkezeti jelenségek elemzése HPSG-ben [Hungarian sentence structure in HPSG]. In: Bartos, Huba (ed.) *Általános Nyelvészeti Tanulmányok XXIII.: Új irányok és eredmények a mondattani kutatásban*. Budapest: Akadémiai Kiadó, pp. 99–138.

# Why and how to differentiate complement raising from subject raising in Dutch

Frank Van Eynde 

Centre for Computational Linguistics, University of Leuven

Liesbeth Augustinus 

Centre for Computational Linguistics, University of Leuven

Proceedings of the 20th International Conference on  
Head-Driven Phrase Structure Grammar

Freie Universität Berlin

Stefan Müller (Editor)

2013

Stanford, CA: CSLI Publications

pages 222–242

Van Eynde, Frank & Liesbeth Augustinus. 2013. Why and how to differentiate complement raising from subject raising in Dutch. In Stefan Müller (ed.), *Proceedings of the 20th International Conference on Head-Driven Phrase Structure Grammar*, Freie Universität Berlin, 222–242. Stanford, CA: CSLI Publications. DOI: 10.21248/hpsg.2013.12. 

## Abstract

In Dutch V-final clauses the verbs tend to form a cluster in which the main verb is separated from its syntactic arguments by one or more other verbs. In HPSG the link between the main verb and its arguments is canonically modeled in terms of *argument inheritance*, also known as *argument composition* or *generalized raising*. When applied to Dutch, this treatment yields a number of problems, making incorrect predictions about the interaction with the binding principles and the passive lexical rule. To repair them this paper proposes an alternative, in which subject raising and complement raising are modeled in terms of different devices. More specifically, while subject raising is modeled in terms of lexical constraints, as for English, complement raising is modeled in terms of a more general constraint on headed phrases. This new constraint not only accounts for complement raising out of verbal complements, it also deals with complement raising out of adjectival and adpositional complements, as well as with complement raising out of PP adjuncts and subject NPs. It is, hence, a rather powerful device. To prevent overgeneration we add a number of constraints. For Dutch, the relevant constraints block complement raising out of CPs, V-initial VPs and P-initial PPs. For English, the Empty COMPS Constraint is sufficient to block complement raising entirely.

## 1 Introduction

In Dutch V-final clauses with more than one verb, the verbs tend to form a cluster, as in (1).

- (1) ... of Peter het boek *zal kunnen vinden*.  
... if Peter the book will can find  
'... if Peter will be able to find the book.'

The result of this clustering is that the main verb, i.c. *vinden* 'find', is separated from its syntactic arguments by other verbs, i.c. the future *zal* 'will' and the modal *kunnen* 'can'. To model the relation between the main verb and its arguments, Head-driven Phrase Structure Grammar canonically employs the device of *argument inheritance*, also known as *argument composition* or *generalized raising* (Hinrichs & Nakazawa, 1989, 1994). In this paper we first present the Argument Inheritance analysis and apply it to (1) (section 2). Then, we show that the application to Dutch yields a number of problems (section 3), and we propose an alternative (section 4).

---

<sup>†</sup>We thank the audiences of the Workshop on Structure and Evidence in Linguistics, better known as the Ivan Sag Fest (Stanford, April 28-30), and of the HPSG 2013 conference (Berlin, August 28-29) for their comments. The research presented in this paper is part of a project on complement raising and cluster formation in Dutch, sponsored by FWO Vlaanderen (2011-2015, G.0.559.11.N.10).

## 2 Argument inheritance

Building on a GPSG proposal in Johnson (1986), Hinrichs & Nakazawa (1989) argue that the German verb cluster is a constituent with a binary branching structure to which the arguments of the main verb are added one at a time. Applying this to the Dutch construction in (1) yields the phrase structure in (2).

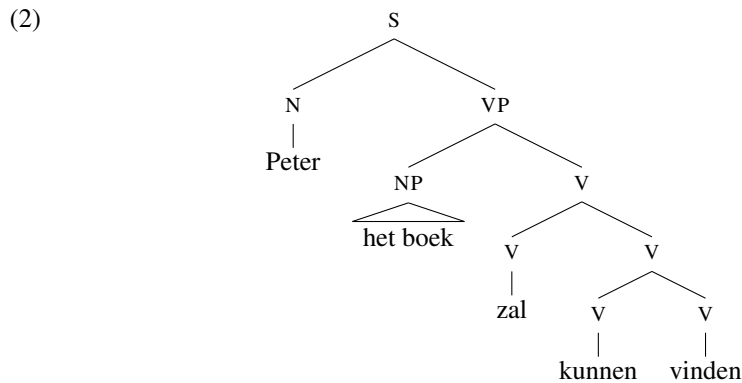

The relation between the main verb and its arguments is modeled in terms of the SUBCAT(EGORIZATION) values of the verbs. The one of the main verb *vinden* 'find' is a list which contains two NPs. The SUBCAT values of the other verbs are more complex: They take a verbal complement as their most oblique argument, and inherit the SUBCAT list of that verbal complement, as in (3), after Hinrichs & Nakazawa (1994).

$$(3) \left[ \text{SUBCAT } [A] \oplus \left\langle \left[ \text{LOCAL} \mid \text{CAT} \left[ \begin{array}{l} \text{HEAD } \textit{verb} \\ \text{SUBCAT } [A] \end{array} \right] \right] \right\rangle \right]$$

Adding this information to (2) yields (4).

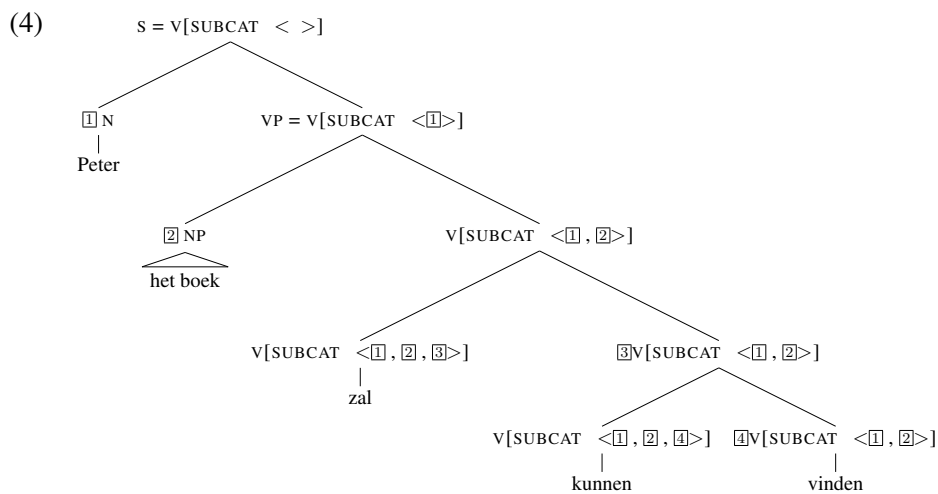

The modal *kunnen* ‘can’ selects the bare infinitive *vinden* ‘find’ (④) as well as the arguments of that infinitive (① and ②), and the resulting cluster (③) is selected by the future *zal* ‘will’, which also inherits the arguments of the cluster. The net result is that the combination *zal kunnen vinden* ‘will be able to find’ has the same SUBCAT list as *vinden* ‘find’. At that point, the direct object and the subject are added and the corresponding SUBCAT requirements in the verbal projection are discarded in the usual way.

In more recent versions of HPSG, SUBCAT is replaced with the valence features SUBJ(ECT) and COMP(LEMENT)S, on the one hand (Pollard & Sag, 1994, chapter 9),<sup>1</sup> and by the lexical ARG-ST feature, on the other hand (Miller & Sag, 1997). Expressing argument inheritance in this notation yields (5).

$$(5) \left[ \text{ARG-ST} \langle \textcircled{1} \rangle \oplus \textcircled{A} \oplus \left\langle \left[ \text{LOCAL} \mid \text{CAT} \begin{bmatrix} \text{HEAD} & \textit{verb} \\ \text{SUBJ} & \langle \textcircled{1} \rangle \\ \text{COMPS} & \textcircled{A} \end{bmatrix} \right] \right\rangle \right]$$

The arguments are differentiated, depending on whether they are realized as subjects or as complements, and both are added to the ARG-ST list of the selecting verb. Application to (1) yields the phrase structure in (6).<sup>2</sup>

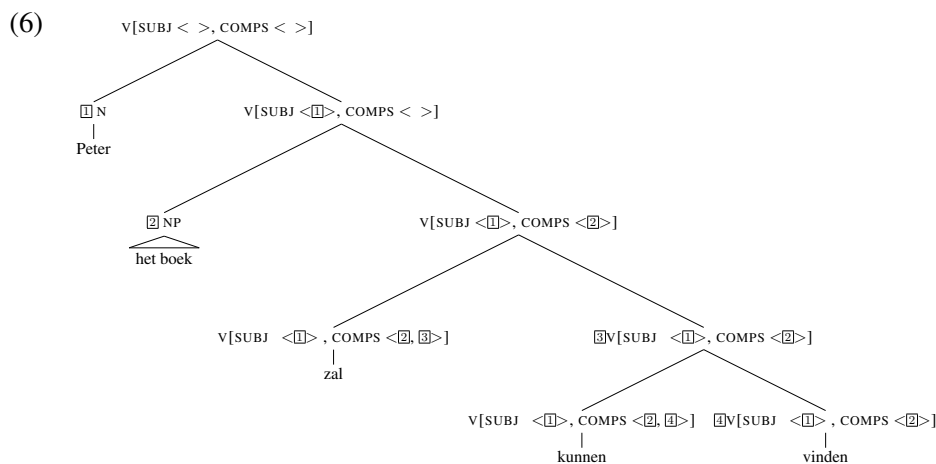

The argument inheritance treatment has turned out to be very influential in HPSG treatments of German and Dutch: Something along the lines of either (3) or (5) was adopted in amongst others Rentier (1994), Bouma & Van Noord (1998),

<sup>1</sup>There is a third valence feature (SP(ECIAL)FIE(R)) that is mainly used to model the selection of a determiner by a nominal. It is omitted here since it does not play any role in the treatment of argument inheritance, see also Van Eynde (2006).

<sup>2</sup>It has been argued that the first argument of a finite verb is a complement in German, see Müller (2002). If that assumption is adopted for Dutch, [1] is on the COMPS list of the future auxiliary. Nothing in this paper hinges on that choice.



Kathol (2000, chapter 8), and Müller (2002, chapter 2). It was also adopted for the treatment of clitic climbing in the Romance languages, as in Abeillé et al. (1998) for French and Monachesi (1998) for Italian.

### 3 Why to differentiate complement raising from subject raising

A common property of the argument inheritance proposals is that subjects and complements are raised in the same way: They are both integrated in the SUBCAT list, c.q. the ARG-ST list, of the selecting verb. This is in fact the reason why argument inheritance is also known as *generalized raising*. What will be argued now is that complement raising ought to be differentiated from subject raising, at least for Dutch. The evidence comes from three sources. They concern the occurrence of complement raising with subject control verbs, the binding properties of subject-to-object raisers, also known as ACI verbs (*Accusativus cum Infinitivo*), and the interaction of complement raising and the passive lexical rule.

#### 3.1 Subject control verbs and complement raising

The formulation of argument inheritance in (5) allows for the occurrence of subject raising without complement raising, since  $\boxed{A}$  may be the empty list.<sup>3</sup> What (5) does not allow, though, is the occurrence of complement raising without subject raising: The SUBJ list of the selected verb is required to contain one *synsem*, and that *synsem* must be identical to the first argument of the selecting verb.

This constraint now is too strict, since complement raising also occurs with subject control verbs, such as *willen* ‘want’ and *proberen* ‘try’. Some instances are provided by the following sentences, taken from LASSY, a treebank for written Dutch (Van Noord et al., 2013). The control verbs are in bold and the raised complements in italics.

- (7) Kasparov beschuldigde Gorbatsjov ervan dat hij *het bloedvergieten*  
 Kasparov accused Gorbatsjov there-of that he the bloodshed  
 niet had **willen** stoppen.  
 not had want.IPP stop.INF  
 ‘Kasparov accused Gorbatsjov that he had not wanted to stop the bloodshed.’ [LASSY, dpc-ind-001648-nl-sen.p.19.s.6]
- (8) ... nadat ze *zowel de PS als de PRL te vriend* had **proberen** te  
 ... after she both the PS and the PRL as friend had try.IPP to  
 houden.  
 keep.INF

<sup>3</sup>In fact, if  $\boxed{A}$  is declared empty, one gets the constraint which is characteristic of the English subject raising verbs (Ginzburg & Sag, 2000, p.22).

‘... after she had tried to keep both the PS and the PRL as an ally.’ [LASSY, WR-P-P-I-0000000106.p.7.s.6]

Notice that the control verbs in these sentences are affected by the IPP phenomenon (*Infinitivus pro Participio*), i.e. the use of the infinitive instead of the past participle in combination with the perfect auxiliary. They also allow complement raising, though, when they are not affected by IPP, as illustrated by (9), quoted from the CGN treebank, a treebank for spoken Dutch (Oostdijk et al., 2002).<sup>4</sup>

- (9) ja en en ik heb 'r **geprobeerd** te bellen maar d'r werd niet  
 yes and and I have her try.PSP to call.INF but there was not  
 opgenomen ...  
 picked-up ...  
 ‘yes and and I’ve tried to call her but there was no reply’ [CGN, fna000583  
 ...351]

Summing up, subject control verbs are obviously not subject raisers, but they do allow complement raising, both in clustering constructions and in the third construction. Besides *willen* ‘want’ and *proberen* ‘try’, they include the verbs in Table 1 (Augustinus & Van Eynde, 2012).

pogen	‘try’	trachten	‘try’
dreigen	‘threaten’	leren	‘learn’
weigeren	‘refuse’	menen	‘mean, intend’
weten	‘manage’	zien	‘intend’
zoeken	‘intend’	durven	‘dare’
komen	‘come’	liggen	‘lie’
lopen	‘walk’	staan	‘stand’
zijn	‘be in the activity of’	zitten	‘sit’

Table 1: Other subject control verbs that allow complement raising

Since the argument inheritance constraint in (5) does not subsume the subject control verbs, we need a separate constraint to model the complement raising in clauses like (7–9):

$$(10) \left[ \text{ARG-ST} \left\langle \text{NP}_{\overline{1}} \right\rangle \oplus \boxed{A} \oplus \left\langle \left[ \text{LOCAL} \mid \text{CAT} \left[ \begin{array}{l} \text{HEAD } verb \\ \text{SUBJ } \left\langle \text{NP}_{\overline{1}} \right\rangle \\ \text{COMPS } \boxed{A} \end{array} \right] \right] \right\rangle \right]$$

Complying with the way in which subject control verbs are canonically differentiated from subject raising verbs (Pollard & Sag, 1994; Sag et al., 2003), this

<sup>4</sup>This is an instance of the so-called third construction (den Besten et al., 1988; den Besten & Rutten, 1989).

constraint requires the unexpressed subject of the selected verb to share its index with the first argument of the selecting verb, rather than its entire *synsem* value. This addition of an extra constraint is by itself unobjectionable, but it does raise the suspicion that we are missing a generalization.

### 3.2 Subject-to-object raisers and the binding principles

In HPSG, the binding principles are canonically defined in terms of obliqueness relations in the ARG-ST list (Pollard & Sag, 1994; Sag et al., 2003).

Principle A: An anaphoric pronoun must be coindexed with a less oblique argument on the same ARG-ST list.

Principle B: A nonanaphoric NP may not be coindexed with a less oblique argument on the same ARG-ST list.

Assuming that raised subjects are integrated in the ARG-ST list of the selecting verb, this makes the right prediction for the subject-to-object raiser *ziet* ‘sees’ in (11).

- (11) a. ... dat hij<sub>i</sub> zich<sub>i/\*j</sub> die wedstrijd niet meteen **ziet** winnen.  
 ... that he<sub>i</sub> himself<sub>i/\*j</sub> that game not immediately sees win  
 ‘... that he does not expect himself to win that game rightaway.’
- b. ... dat hij<sub>i</sub> hem<sub>j/\*i</sub> die wedstrijd niet meteen **ziet** winnen.  
 ... that he<sub>i</sub> him<sub>j/\*i</sub> that game not immediately sees win  
 ‘... that he doesn’t expect him to win that game rightaway.’

The raised reflexive pronoun *zich* ‘himself’ in (11a) must be coindexed with the subject of *ziet* ‘sees’, yielding the interpretation that he does not expect himself to win the contest. Similarly, the raised personal pronoun *hem* ‘him’ in (11b) cannot be coindexed with the subject of *ziet*, yielding the interpretation that he does not expect that person to win the contest. Raised subjects thus behave as *bona fide* arguments of the matrix verb, as illustrated by the ARG-ST list of *ziet* for the sentences in (11).

- (12) a. *ziet*: ARG-ST <NP<sub>i</sub>,  $\boxed{1}$  NP<sub>i/\*j</sub>, (...)> V[SUBJ < $\boxed{1}$ >]>  
 b. *ziet*: ARG-ST <NP<sub>i</sub>,  $\boxed{1}$  NP<sub>j/\*i</sub>, (...)> V[SUBJ < $\boxed{1}$ >]>

Raised complements, by contrast, show the opposite behavior.

- (13) a. \* ... dat hij<sub>i</sub> ons zich<sub>i</sub> niet meteen **ziet** uitschakelen.  
 ... that he<sub>i</sub> us himself<sub>i</sub> not immediately sees eliminate
- b. ... dat hij<sub>i</sub> ons hem<sub>i/j</sub> niet meteen **ziet** uitschakelen.  
 ... that he<sub>i</sub> us him<sub>i/j</sub> not immediately sees eliminate  
 ‘... that he doesn’t expect us to eliminate him rightaway.’

If the raised reflexive pronoun in (13a) is integrated in the ARG-ST list of *ziet* and coindexed with its subject, as in (14a), then it complies with binding principle A, but the sentence is nonetheless illformed. Conversely, if the raised personal pronoun in (13b) is integrated in the ARG-ST list of *ziet* and coindexed with its subject, as in (14b), it violates binding principle B, but this interpretation is impeccable.

- (14) a. *ziet*: ARG-ST <NP<sub>i</sub>,  $\boxed{1}$  NP,  $\boxed{2}$  NP<sub>i</sub>, V[SUBJ < $\boxed{1}$ >, COMPS < $\boxed{2}$ >]>  
 b. *ziet*: ARG-ST <NP<sub>i</sub>,  $\boxed{1}$  NP,  $\boxed{2}$  NP<sub>i/j</sub>, V[SUBJ < $\boxed{1}$ >, COMPS < $\boxed{2}$ >]>

As a consequence, we either need to tinker with the binding principles, or we have to treat the raised complements in another way than the raised subjects, integrating the latter but not the former in the ARG-ST list of the selecting verb.

### 3.3 Passive and complement raising

HPSG canonically treats passivization in terms of a lexical rule which reshuffles the order of the arguments on the ARG-ST list, as in (15), after (Sag et al., 2003, p.313).

$$(15) \left[ \begin{array}{l} tv-lxm \\ \text{PHON } \boxed{A} \\ \text{ARG-ST } \langle \text{NP}_i \rangle \oplus \boxed{B} \end{array} \right] \Rightarrow_{LR} \left[ \begin{array}{l} \text{PHON } F_{psp}(\boxed{A}) \\ \text{SS} | \text{LOC} | \text{CAT} | \text{HEAD} | \text{VFORM } pas \\ \text{ARG-ST } \boxed{B} \oplus \langle \langle \text{PP}_i \rangle \rangle \end{array} \right]$$

This rule relates a transitive verbal lexeme to its participial form, fixing the VFORM value to *passive* and changing the order in the ARG-ST list: The second argument of the verbal lexeme becomes the first argument of its passive counterpart.

Assuming that raised subjects are integrated in the ARG-ST list of the selecting verb, this makes the right prediction for the subject-to-object raiser *expect* in (16).

- (16) a. We expect them to leave tomorrow.  
 b. They are expected to leave tomorrow.

Since the noun phrase which is realized by *them* is the second argument of the lexeme *expect*, it can become the first argument of its passive counterpart *expected*.

Raised complements, by contrast, behave differently, as illustrated in (17).

- (17) a. ... dat hij *ons* **probeerde** het huis te verkopen.  
 ... that he us tried the house to sell  
 ‘... that he tried to sell us the house.’  
 b. \* ... dat *wij* **werden geprobeerd** het huis te verkopen.  
 ... that we were tried the house to sell

The italicized complement of *verkopen* ‘sell’ in (17a) is raised and realized as a dependent of the subject control verb *proberen* ‘try’, but in contrast to the raised subject in (16) it cannot become the first argument of the passive *geprobeerd* ‘tried’.

As a consequence, if we want to preserve a treatment of passivization in terms of reshuffling along the lines of (15), then we should not integrate the raised complements in the ARG-ST list of the selecting verb.

## 4 An alternative treatment of complement raising

The development of the alternative proceeds in four steps. First, we differentiate complement raising from subject raising. Second, we differentiate complement raising from complement extraction. Third, we show how the new treatment of complement raising naturally extends to a number of other phenomena, including adposition stranding. Fourth, we propose some constraints on complement raising.

### 4.1 Complement raising versus subject raising

In order to avoid the problems in the interaction with the binding principles and the passive lexical rule, we assume that raised subjects are integrated in the ARG-ST list of the selecting verb, while raised complements are not.

For the treatment of subject raising this implies that we can use the same lexical constraints as those that are used for English, i.e. one for subject-to-subject raisers and one for subject-to-object raisers, as in (18) (Ginzburg & Sag, 2000, 22).<sup>5</sup>

- (18) a. *s-rsg-lx*  $\Rightarrow$  [ARG-ST  $\langle$ [LOC  $\boxed{1}$ ], [SUBJ  $\langle$ LOC  $\boxed{1}$ ]]]  
 b. *orv-lx*  $\Rightarrow$  [ARG-ST  $\langle$ NP, [LOC  $\boxed{1}$ ], [SUBJ  $\langle$ LOC  $\boxed{1}$ ]]]

A treatment in terms of **lexical** constraints is appropriate since the two types subsume a limited number of verbs. The subject raising lexemes (*s-rsg-lx*), for instance, include the modal, temporal and passive auxiliaries, while the object raising lexemes (*orv-lx*) include a number of perception verbs and causative verbs.

For the treatment of complement raising, by contrast, we adopt the following **phrasal** constraint.

- (19) 
$$\left[ \begin{array}{l} hd-ph \\ SS | LOC | CAT | COMPS \ list \oplus \ \boxed{Z} \\ \text{NONHEAD-DTR} | SS | LOC | CAT | COMPS \ \boxed{Z} \end{array} \right]$$

In a headed phrase, the COMPS list of the nonhead daughter is appended to the COMPS list of the mother.<sup>6</sup> The  $\boxed{Z}$  list may be empty, but it may also contain one or more members. In (20), for instance, which is our representation of (1),  $\boxed{Z}$  corresponds to  $\langle \boxed{2} \rangle$ .

<sup>5</sup>In this version, the sharing is limited to the objects of type *local*. In other versions, including that of Pollard & Sag (1994), the sharing concerns objects of type *synsem*. Nothing in this paper hinges on that distinction.

<sup>6</sup>In a non-headed phrase, such as a coordinate phrase, the COMPS list of the mother is identical to the COMPS list of each of the conjunct daughters.

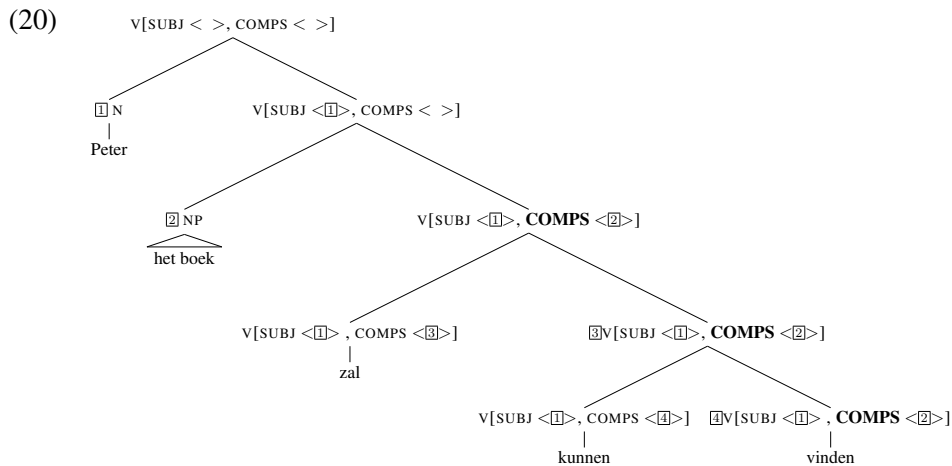

Notice that the modal *kunnen* ‘can’ inherits the subject requirement of its infinitival complement, but not its COMPS list. The latter is propagated directly from the nonhead daughter to the mother. The same holds for the future *zal* ‘will’: It inherits the SUBJ list of its infinitival complement, but not its COMPS list.

Small as it is, this difference provides exactly what we need to avoid the problems with the argument inheritance treatment: It allows for complement raising in cases where there is no subject raising, and it does not integrate the raised complements in the ARG-ST list of the selecting verb.

## 4.2 Complement raising versus complement extraction

Complement raising need not only be differentiated from subject raising, but also from complement extraction. The latter concerns a long distance dependency that may cross clause boundaries, as in (21–22).

- (21) Who do you think she said she would date?  
 (22) Wie beweert ze dat ze in Parijs ontmoet hebben?  
 who claims she that they in Paris met have  
 ‘Who does she claim they met in Paris?’

The complements of *date* and *ontmoet* ‘met’ are extracted and realized as a filler of the main clause. In HPSG, this is modeled in terms of a lexical rule which subtracts elements from the COMPS list and adds them to the nonlocal SLASH list, see (Ginzburg & Sag, 2000).

Complement raising, by contrast, is a middle distance dependency, and does not cross clause boundaries. To make this more precise let us adopt some notions of topological field theory, i.e. the analysis of the clause in terms of two poles (*Satzklammer*) and three fields (*Vorfeld*, *Mittelfeld*, *Nachfeld*). This style of analysis has been very influential in Dutch and German descriptive syntax (Haeseryn et al., 1997; Dudenredaktion, 2006), and some of its insights and terminology have

been imported in HPSG (Kathol, 2000; Müller, 2002). Pursuing in this direction let us make the assumption that complements cannot be raised beyond the first pole (*linke Satzklammer*). This is the position that is taken by the complementizer in verb-final clauses and by the finite verb in verb-initial clauses, i.e.  $V_1$  and  $V_2$  clauses.

That complementizers are a boundary for complement raising is illustrated in (23).

- (23) a. ...dat ze beweert **dat** ze *hem* in Parijs ontmoet hebben.  
 ...that she claims that they him in Paris met have  
 ‘...that she claims that they met him in Paris.’  
 b. \* ...dat ze *hem* beweert **dat** ze in Parijs ontmoet hebben.  
 \* ...that she him claims that they in Paris met have

The italicized complement of *ontmoet* ‘met’ cannot be raised out of the clause that is introduced by the complementizer *dat* ‘that’.

That finite verbs are a boundary for complement raising is less obvious, since it is possible to realize the complement of the main verb in the Vorfeld, as in (24).

- (24) Dat boek zal Peter toch niet kunnen vinden.  
 that book shall Peter anyway not can find  
 ‘That book, Peter will not be able to find anyway.’

Notice, though, that this is an instance of topicalization, and that topicalization is canonically treated as a long distance dependency in HPSG, amongst others because it can cross clause boundaries, as in (25).

- (25) That man I wish I had never known.

A useful test for differentiating topicalization from complement raising in Dutch is exemplified by the contrast in (26).

- (26) a. Peter zal jou/je toch niet kunnen vinden.  
 Peter shall you/you.RED anyway not can find  
 ‘Peter will not be able to find you anyway.’  
 b. Jou/\*je zal Peter toch niet kunnen vinden.  
 you/\*you.RED shall Peter anyway not can find  
 ‘Me Peter will not be able to find anyway.’

Pronominal complements can be raised out of a verb cluster, as in (26a), no matter whether they take the full form or a phonologically reduced form, i.e. a form with a mute vowel or without vowel. Extraction, by contrast, as in (26b), is only possible for the full form (Van Eynde, 1999).<sup>7</sup>

<sup>7</sup>This restriction holds for extracted *complements*. Subjects may always occur in the Vorfeld, no matter whether they are full forms or reduced forms.

Taking stock, the middle distance nature of complement raising is clear from the fact that it cannot go beyond the first pole: It is bounded by the complementizer in verb-final clauses and by the finite verb in verb-initial clauses. How these constraints can be spelled out in formal terms is discussed in section 4.4.

### 4.3 Extensions

So far, we have focussed on complement raising out of nonfinite verbal complements. This, however, is not the only type of raising that the phrasal constraint in (19) allows. It also allows raising out of nonverbal complements, since it does not put any constraints on the syntactic category of the nonhead daughter. Moreover, it also allows raising out of subjects and adjuncts, since (19) applies to all headed phrases.

#### 4.3.1 Complement raising out of nonverbal complements

Some examples of complement raising out of adjectival complements are given in (27–28).

- (27) ...dat we *die hittegolf* nog steeds niet **kwijt** zijn!  
 ...that we that heat wave still always not lost are  
 ‘... that we are not finished with that heat wave yet!’ [LASSY, WS-U-E-A-0000000221.p.32.s.2]
- (28) ...dat de bevolking van Zimbabwe *haar huisbakken* **dictator**  
 ...that the people of Zimbabwe her home-grown dictator  
 onderhand meer dan **beu** is.  
 by now more than fed-up is  
 ‘... that the people of Zimbabwe are more than fed up with their homegrown dictator by now.’ [LASSY, WR-P-P-I-0000000219.p.4.s.4]

The italicized nominals are complements of the predicative adjectives in bold, but they are not realized within the AP. Instead, they are raised and realized in the left part of the Mittelfeld, preceding the VP adjuncts.

Complement raising also subsumes the instances of adposition stranding in (29–30).<sup>8</sup>

- (29) ...dat zij *daar* nog wel **van** hield.  
 ...that she there still rather of liked  
 ‘... that she rather liked it.’ [CGN, fna000741\_12]
- (30) ...als je *er* pas achteraf **over** nadenkt, is het misschien te laat.  
 ...if you there only later about think-of, is it maybe too late

<sup>8</sup>For a treatment of adposition stranding in Dutch, see a.o. Van Riemsdijk (1978) and Beeken (1991).



‘...if you only think about it afterwards, it may be too late.’ [LASSY, WR-P-P-C-0000000047.txt-10]

Also here, the italicized pronouns are complements of the adpositions in bold, but they are not realized within the PP. Instead, they are raised and realized in the left part of the Mittelfeld, preceding the VP adjuncts, as illustrated by the representation of (29) in (31).

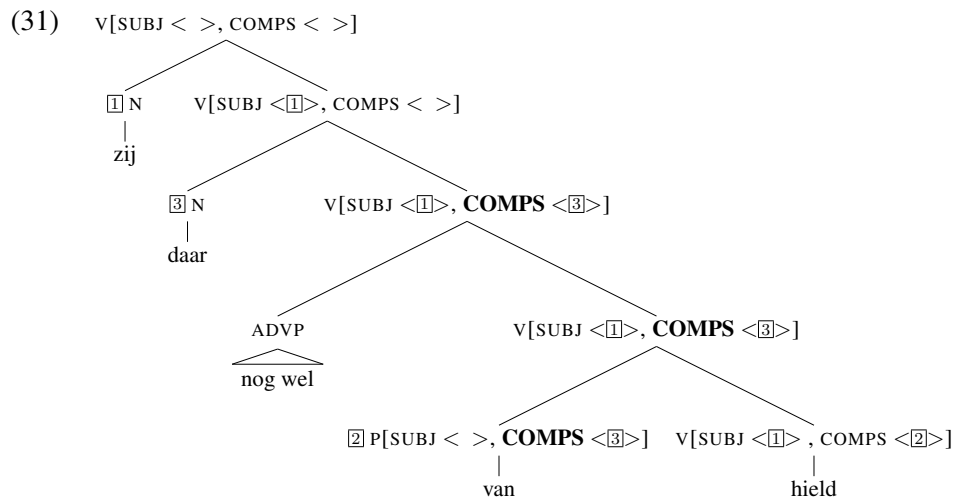

The unsaturated COMPS requirement of the adposition ([3]) is inherited by the verbal projection and discharged after the addition of *daar* ‘there’. Notice that the adposition has an empty SUBJ list, in accordance with the canonical HPSG assumption that argument marking adpositions do not select a subject. In the context of this paper, it provides further evidence for the claim that complement raising may occur in environments where there is no subject raising.

Since there are adjectives which take adpositional complements, complement raising can be applied iteratively, as in (32).

- (32) ... dat hij *daar* niet **blij** mee is.  
 ... that he there not happy with is  
 ‘... that he is not happy with that.’

The pronominal complement *daar* ‘there’ is first raised out of the PP, then out of the predicative AP, and finally out of the V-final VP, as illustrated in (33).

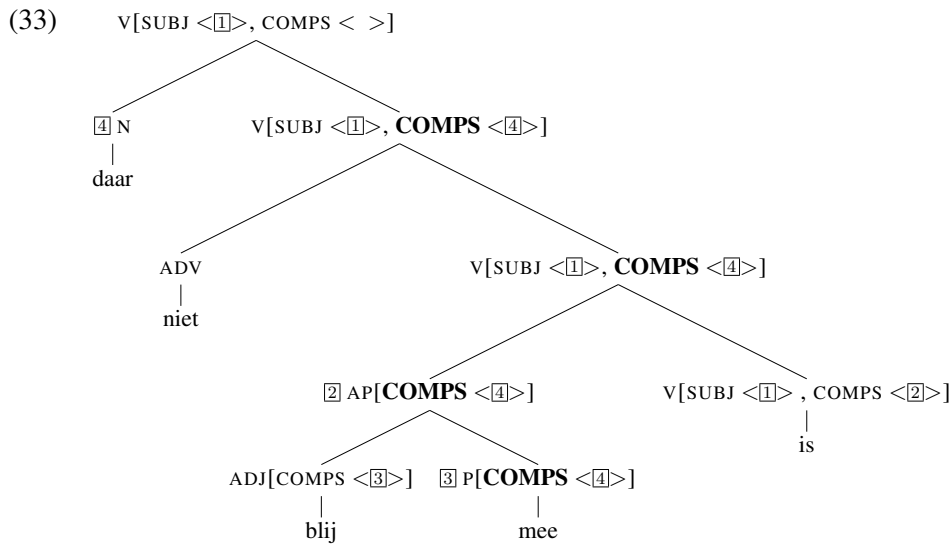

This is comparable to the iterative subject raising in sequences like (34).

(34) He does not seem to be likely to win this game.

The surface subject of *does* is the understood subject of *win this game*, and the relation is mediated by a sequence of subject raising lexemes, including *to*, *likely*, *be*, *seem* and *does*.

### 4.3.2 Complement raising out of functors and subjects

The previous examples all concerned raising out of complements, but the constraint on complement raising in (19) does not require this: It also allows the nonhead daughter to be a functor or a subject. (35), for instance, is an example of complement raising out of a PP adjunct.

(35) ... dat hij *er* veel verliezen **door** heeft geleden.  
 ... that he there many losses by has suffered  
 ‘... that he suffered many losses because of it.’

The italicized pronoun is a complement of the adposition *door* ‘by’ and the latter heads a PP adjunct that specifies the cause of the losses.

Raising out of subjects is exemplified in (36).

(36) ... dat *er* nog maar twee **van** klaar zijn.  
 ... that there still but two of ready are  
 ‘... that only two of them are ready.’

The italicized pronoun is a complement of the adposition *van* ‘of’, which heads the PP adjunct of the cardinal *twee* ‘two’ which in its turn heads the subject of the clause, as spelled out in (37).

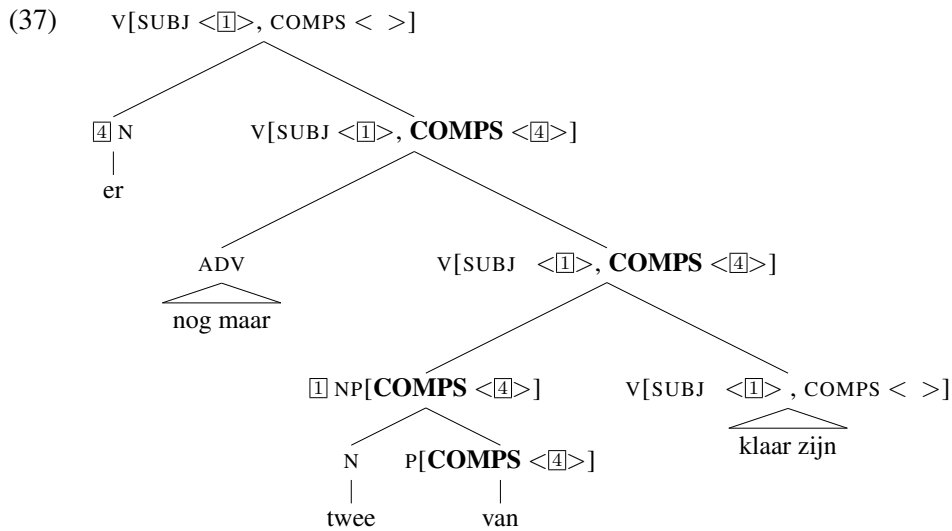

## 4.4 Constraints

Given the treatment of complement raising in terms of a phrasal —rather than a lexical— constraint and given the rather permissive nature of its formulation in (19), an obvious question is whether it is not too permissive. The equally obvious answer is that excessive permissivity can be avoided by the addition of extra constraints on (19). To show how this can be done we first discuss English and then return to Dutch.

### 4.4.1 English

English is a language that allows subject raising and complement extraction, but assuming that it obeys the Empty COMPS Constraint, as defined in Ginzburg & Sag (2000, 33), it does not allow complement raising.

(38) Empty COMPS Constraint (Ginzburg & Sag, 2000, 33)

$$\textit{phrase:} \left[ \text{COMPS} \langle \rangle \right] \rightarrow \dots$$

Indeed, if phrases are required to have an empty COMPS list, then it follows that the  $\square$  list in the phrasal constraint on complement raising in (19) must be empty and, hence, that complement raising is blocked.

The fact that English allows adposition stranding does not provide any evidence against this assumption, since the stranding invariably results from complement extraction, as in (39).

- (39) a. *What* do you think they were talking **about**?  
 b. *This* I would never dare talk **about** in her presence.

Stranding that results from complement raising, as in (40), is not possible.

- (40) a. \* John heard us *this* talk **about**.  
 b. \* We saw him *that* give a talk **about**.

In that respect, English differs from Dutch, where the equivalents of (40) are well-formed.

- (41) a. Jan heeft *er* ons **over** horen praten.  
 Jan has there us about hear talk  
 ‘Jan heard us talk about it.’  
 b. We hebben hem *daar* een lezing **over** zien geven.  
 we have him there a talk about see give  
 ‘We saw him give a talk about that.’

In sum, the addition of the Empty COMPS Constraint suffices to rule out complement raising from the language.

#### 4.4.2 Dutch

Since Dutch does not abide by the Empty COMPS Constraint, it allows complement raising, but this does not mean that its complements can be raised anywhere. For a start, they cannot be raised beyond the first pole, as demonstrated in section 4.2. To model this for the case in which the first pole is a complementizer we add the constraint in (42).

$$(42) \left[ \begin{array}{l} hd-ph \\ SS | LOC | CAT \left[ \begin{array}{l} HEAD \text{ complementizer} \\ COMPS \langle \rangle \end{array} \right] \end{array} \right]$$

Phrases which are headed by a complementizer are required to have an empty COMPS list. This suffices to block complement raising out of CPs.<sup>9</sup>

If the first pole is a finite verb, we need an extra feature to model the relevant constraint. We call it POSITION and add it to the HEAD values of verbs. Its possible values are given in (43).

$$(43) \begin{array}{c} position \\ \wedge \\ initial \quad final \end{array}$$

In terms of this dichotomy, the nonfinite verbs are invariably *final* and the imperative forms *initial*. The other finite forms can occur in either position, and hence receive the underspecified *position* value.<sup>10</sup>

<sup>9</sup>It does not block complement extraction, though, since it does not require the SLASH value of a CP to be empty.

<sup>10</sup>The term *initial* subsumes both  $v_1$  and  $v_2$ .

<i>final</i>	nonfinite forms
<i>initial</i>	imperative forms
<i>position</i>	nonimperative finite forms

Table 2: Three types of verb forms

With this addition the constraint which blocks complement raising out of v-initial VPs can now be spelled out as in (44).

$$(44) \left[ \begin{array}{l} hd-ph \\ \\ SS | LOC | CAT \left[ \begin{array}{l} HEAD \left[ \begin{array}{l} verb \\ POSITION \quad initial \end{array} \right] \\ COMPS \langle \rangle \end{array} \right] \end{array} \right]$$

Phrases which are headed by a verb that is in v-initial position, are required to have an empty COMPS list, just like CPs.

Together, the constraints in (42) and (44) model the fact that complements cannot be raised beyond the first pole. As such, they capture what differentiates complement raising from complement extraction.

A less conspicuous constraint concerns the raising out of PPs. To pave the way for its treatment we start from the observation that Dutch adpositions come in three types: There are those that invariably follow their complement, such as *toe* ‘to’ and *mee* ‘with’, there are those that invariably precede their complement, such as *tot* ‘to, till’ and *met* ‘with’, and there are those that can precede as well as follow their complement, such as *in* ‘in’ and *van* ‘of’. Table 3 provides a survey.

<i>final</i>	<i>mee, toe, af, heen</i>
<i>initial</i>	<i>met, tot, te, sinds, sedert, als, tijdens, wegens, volgens, ...</i>
<i>position</i>	<i>in, op, van, aan, bij, door, ...</i>

Table 3: Three types of adpositions

The distinction is not only relevant to treat the linear order within the PP, it also correlates with some other facts. Realization in the Nachfeld, for instance, also known as PP-over-V, is possible for P-initial PPs, as shown in (45), but not for P-final PPs, as shown in (46–47).

- (45) a. ... dat we nog steeds [**op** een goede afloop] hopen.  
 ... that we still always for a good outcome hope  
 ‘... that we are still hoping for a good outcome.’  
 b. ... dat we nog steeds hopen [**op** een goede afloop].  
 ... that we still always hope for a good outcome  
 ‘... that we are still hoping for a good outcome.’

- (46) a. ... dat we nog steeds [daar **op**] hopen.  
 ... that we still always there for hope  
 ‘... that we are still hoping for that.’  
 b. \* ... dat we nog steeds hopen [daar **op**].  
 ... that we still always hope there for
- (47) a. ... dat hij voorzichtig [de garage **in**] reed.  
 ... that he carefully the garage in drove  
 ‘... that he drove carefully into the garage.’  
 b. \* ... dat hij voorzichtig reed [de garage **in**].  
 ... that he carefully drove the garage in

Conversely, complement raising is possible out of P-final PPs, as shown in (48–49), but not out of P-initial PPs, as shown in (50).

- (48) a. ... dat we nog steeds [daar **op**] hopen.  
 ... that we still always there for hope  
 ‘... that we are still hoping for that.’  
 b. ... dat we *daar* nog steeds **op** hopen.  
 ... that we there still always for hope  
 ‘... that we are still hoping for that.’
- (49) a. ... dat hij voorzichtig [de garage **in**] reed.  
 ... that he carefully the garage in drove  
 ... that he drove carefully into the garage.’  
 b. ... dat hij *de garage* voorzichtig **in** reed.  
 ... that he the garage carefully in drove  
 ... that he drove carefully into the garage.’
- (50) a. ... dat we nog steeds [**op** een goede afloop] hopen.  
 ... that we still always for a good outcome hope  
 ‘... that we are still hoping for a good outcome.’  
 \* ... dat we *een goede afloop* nog steeds **op** hopen.  
 ... that we a good outcome still always for hope

To model the constraint that complements cannot be raised out of P-initial PPs we propose a constraint that resembles the one in (44).

$$(51) \left[ \begin{array}{l} hd-ph \\ SS | LOC | CAT \left[ \begin{array}{l} HEAD \left[ \begin{array}{l} adposition \\ POSITION \quad initial \end{array} \right] \\ COMPS \langle \rangle \end{array} \right] \end{array} \right]$$

(51) requires the P-initial PPs to have an empty COMPS list, just like the V-initial VPs and the CPs.

When this constraint is combined with the observations about PP-over-V, it correctly accounts for the fact that adpositions cannot be stranded in the Nachfeld.

- (52) a. \* ... dat we *een goede afloop* nog steeds hopen **op**  
... that we a good outcome still always hope for
- b. \* ... dat hij *daar* nog steeds hoopt **op**  
... that he there still always hopes for
- c. \* ... dat hij *de garage* voorzichtig reed **in**  
... that he the garage carefully drove in

(52a) is illformed, since (51) does not allow to raise a complement out of a P-initial PP, and (52b–52c) are illformed, since P-final PPs are not allowed in the Nachfeld.

Given that complementizers are invariably CP-initial, at least in the Germanic and the Romance languages, it is tempting to replace the three constraints with one more general constraint, blocking complement raising out of all head-initial phrases. This, however, would be too strict, since it is possible to raise complements out of head-initial APs and NPs, as shown in (33) and (37), respectively.

Further investigation will reveal whether the three constraints suffice to prevent overgeneration and whether it is possible to formulate them in more general terms. What is noteworthy, though, is that they mesh remarkably well with the fact that English does not allow complement raising, since English VPs and PPs are invariably head-initial.

## 5 Conclusion

To model the raising of complements out of verb clusters HPSG canonically employs the device of *argument inheritance*, also known as *argument composition* or *generalized raising* (section 2). When applied to Dutch, its interaction with the binding principles and the passive lexical rule yields erroneous predictions (section 3). As an alternative, we propose to employ different devices for subject raising and complement raising: While the former is modeled in terms of lexical constraints, as in English, the latter is modeled in terms of a constraint on headed phrases (section 4). This constraint also subsumes other instances of complement raising, such as adposition stranding in Dutch. In order to avoid overgeneration, we added a number of constraints to prevent complement raising out of CPs, V-initial VPs and P-initial PPs.

In future work we will further explore the ramifications of this proposal for Dutch, investigating when complement raising is obligatory and when it is optional. We also intend to explore the potential of this proposal for the treatment of middle distance dependencies in other languages, such as clitic climbing in the Romance languages and clustering in German.

## References

- Abeillé, Anne, Danièle Godard, Philip Miller & Ivan A. Sag. 1998. French bounded dependencies. In S. Balari & L. Dini (eds.), *Romance in HPSG*, 1–54. Stanford: CSLI Publications.
- Augustinus, Liesbeth & Frank Van Eynde. 2012. A Treebank-based Investigation of IPP-triggering Verbs in Dutch. In I. Hendrickx, S. Kübler & K. Simov (eds.), *Proceedings of TLT 11*, 7–12. Lisbon: Colibri.
- Beeken, Jeannine. 1991. *Spiegelstructuur en variabiliteit. pre- en postposities in het Nederlands*: University of Leuven dissertation.
- den Besten, Hans & Jean Rutten. 1989. On Verb Raising, Extraposition and Free Word Order in Dutch. In D. Jaspers, W. Klooster, Y. Putseys & P. Seuren (eds.), *Sentential Complementation and the Lexicon: Studies in Honour of Wim de Geest*, 41–56. Dordrecht: Foris.
- den Besten, Hans, Jean Rutten, Tonjes Veenstra & Joop Veld. 1988. Verb Raising, Extrapositie en de Derde Constructie. Unpublished manuscript.
- Bouma, Gosse & Gertjan Van Noord. 1998. Word Order Constraints on Verb Clusters in German and Dutch. In E. Hinrichs (ed.), *Complex Predicates in Non-derivational Syntax*, New York: Academic Press.
- Dudenredaktion. 2006. *DUDEN. Die Grammatik. Unentbehrlich für richtiges Deutsch*. Mannheim/Leipzig/Vienna/Zürich: Dudenverlag.
- Ginzburg, Jonathan & Ivan A. Sag. 2000. *Interrogative Investigations*. Stanford: CSLI Publications.
- Haeseryn, Walter, K. Romijn, Guido Geerts, J. de Rooij & Maarten C. van den Toorn. 1997. *Algemene Nederlandse spraakkunst*. Nijhoff and Wolters Plantyn.
- Hinrichs, Erhard & Tsuneko Nakazawa. 1989. Flipped out: AUX in German. In *Papers from the 25th Regional Meeting of the Chicago Linguistic Society*, 193–202. Chicago.
- Hinrichs, Erhard & Tsuneko Nakazawa. 1994. Linearizing AUXs in German Verbal Complexes. In J. Nerbonne, K. Netter & C. Pollard (eds.), *German in Head-driven Phrase Structure Grammar*, 11–37. Stanford: CSLI Publications.
- Johnson, Mark. 1986. A GPSG account of VP structure in German. *Linguistics* 24. 871–882.
- Kathol, Andreas. 2000. *Linear Syntax*. Oxford University Press.
- Miller, Philip H. & Ivan A. Sag. 1997. French Clitic Movement without Clitics or Movement. *Natural Language and Linguistic Theory* 15. 573–639.



- Monachesi, Paola. 1998. Decomposing Italian clitics. In S. Balari & L. Dini (eds.), *Romance in HPSG*, 305–357. Stanford: CSLI Publications.
- Müller, Stefan. 2002. *Complex Predicates*. Stanford: CSLI Publications.
- Oostdijk, Nelleke, Wim Goedertier, Frank Van Eynde, Louis Boves, Jean-Pierre Martens, Michael Moortgat & Harald Baayen. 2002. Experiences from the Spoken Dutch Corpus Project. In M. Gonzalez Rodriguez & C.P. Saurez Araujo (eds.), *Proceedings of LREC 3*, 340–347. Paris.
- Pollard, Carl & Ivan Sag. 1994. *Head-driven Phrase Structure Grammar*. Stanford/Chicago: CSLI Publications and University of Chicago Press.
- Rentier, Gerrit. 1994. Dutch Cross Serial Dependencies in HPSG. In *Proceedings of COLING 94*, 818–822. Kyoto, Japan.
- Sag, Ivan A., Thomas Wasow & Emily Bender. 2003. *Syntactic Theory. a Formal Introduction. Second Edition*. Stanford, California: CSLI Publications.
- Van Eynde, Frank. 1999. Major and minor pronouns in Dutch. In G. Bouma, E. Hinrichs, G.-J. Kruijff & R. Oehrle (eds.), *Constraints and Resources in Natural Language Syntax and Semantics*, 137–151. Stanford: CSLI Publications.
- Van Eynde, Frank. 2006. NP-internal agreement and the structure of the noun phrase. *Journal of Linguistics* 42. 139–186.
- Van Noord, Gertjan, Gosse Bouma, Frank Van Eynde, Daniël de Kok, Jelmer van der Linde, Ineke Schuurman, Erik Tjong Kim Sang & Vincent Vandeghinste. 2013. Large Scale Syntactic Annotation of Written Dutch: Lassy. In P. Spyns & J. Odiijk (eds.), *Essential Speech and Language Technology for Dutch*, 147–164. Springer.
- Van Riemsdijk, Henk. 1978. *A Case Study in Syntactic Markedness*. Lisse: The Peter de Ridder Press.

**Part II**

**Contributions to the Workshop**

# Where is non-active morphology?

Artemis Alexiadou 

Universität Stuttgart

Proceedings of the 20th International Conference on  
Head-Driven Phrase Structure Grammar

Freie Universität Berlin

Stefan Müller (Editor)

2013

Stanford, CA: CSLI Publications

pages 244–262

Alexiadou, Artemis. 2013. Where is non-active morphology? In Stefan Müller (ed.), *Proceedings of the 20th International Conference on Head-Driven Phrase Structure Grammar, Freie Universität Berlin*, 244–262. Stanford, CA: CSLI Publications. DOI: 10.21248/hpsg.2013.13.



## 1 Introduction

As Anderson (1982) stated, it is appropriate to recognize, internal to the theory of grammar, a field of study concerning itself with the shape and internal structure of words, namely morphology. However, among linguists there is a lot of disagreement concerning the interaction between morphology and phonology or syntax and most importantly with respect to the question whether the syntactic and the word formation components should be completely separated from each other or not. Consider, in this light, passive formation. Wasow (1977) put forth the proposal that we need to distinguish between two types of passive formation: adjectival passive formation takes place in the lexicon, while verbal passive formation takes place in the syntax. This difference in the locus of application of passive formation is reflected in a number of differences between the two processes: lexical operations, such as adjectival passive formation, are idiosyncratic in form and meaning, while syntactic operations, such as verbal passive formation, have basically no exceptions and are productive.

The examples in (1) and (2), from Wasow (1977), provide evidence for this distinction. As shown in (1), adjectival passives can have idiosyncratic meaning (1a), and appear in idiosyncratic form (1b), while this is not the case for the verbal passive in (1c):

- (1) a. the hung jury (= a jury that cannot agree upon a verdict)  
b. the shaven man  
c. John was being shaved

Moreover, as Wasow noted, not all verbs can form adjectival passives; some verbs can form such passives only if accompanied by an adverb, see (2):

- (2) These specimens look \*(recently) found

While in the recent literature this partition has been challenged, see e.g. Embick (2004), Kratzer (2000), Anagnostopoulou (2003) among others, differences in word formation processes such as the above led other researchers to propose a similar partition. For instance, it has been proposed that thematic operations, which affect the argument structure of a verb (e.g. passivization, reflexivization etc.) are parametrized in the following sense: in some languages they are allowed to apply in the lexicon, while in others they can apply in the syntax, see (3), from Reinhart & Siloni (2005). When a process takes place in the lexicon, it is accompanied by lack of productivity, and semantic non-transparency, in a manner to be made precise below:

- (3) UG allows thematic operations to apply in the lexicon or in the syntax

As Reinhart & Siloni (op.cit.) argue, there are languages such as Hebrew and Hungarian whose parameter is set to lexicon, while there are languages such as French whose parameter is set to syntax, but see Doron & Rappaport Hovav (2009) for critical discussion.

The main focus of this paper is to discuss the complex interaction between morphology and thematic operations that are associated with argument structure alternations, such as verbal passivization, and dispositional middle formation. As has been discussed in the literature, languages differ with respect to the properties of these two operations in precisely the ways that can be taken as evidence for the parameter in (3), i.e. in terms of productivity and semantic non-transparency. I will discuss these differences here by looking at data from Semitic, Greek, and English. I will offer an alternative explanation that dispenses with (3), crucially following the line of argumentation in Marantz (2001), Embick (2004), and Anagnostopoulou (2003). In the last section, I will discuss the case of deponent verbs, a case that represents a mismatch between form and function. The rather idiosyncratic behavior of deponents led several researchers to assume that these are special, and should be somehow listed, thus providing further evidence for word formation processes that take place in the lexicon.

## **2. Verbal passivization**

In this section, I will look at the properties of verbal passivization in languages such as Greek, dialects of Arabic and Hebrew. While in languages such as English and German nearly all transitive verbs can form a passive variant, passive formation is restricted in Greek, and in certain Arabic dialects. In Hebrew, we find a very complex interaction between agency and Voice, which I will briefly summarize relying on Doron's (2003) description and analysis. What will become clear from this discussion is that we can distinguish between two types of languages: languages like English, German and Standard Arabic show productive and semantically transparent passivization. The same holds for the causative and the intensive verbal template of Hebrew. In contrast, Palestinian Arabic, Greek, and the simple template of Hebrew have what we can call an underspecified Voice (see Embick 1998). In these languages, the particular morphology used to mark intransitive variants is not uniquely associated with passive semantics, but can also be used for the formation of reflexives and anticausatives. In addition, it can be used on basic entries as well, i.e. to build intransitive entries in the absence of a transitive counterpart (deponent verbs). All these facts point to the conclusion that the mechanisms that form passives in the former group of languages differ significantly from those available to the latter group.

I will discuss data from two dialects of Arabic first and then turn to Greek. The discussion of the Hebrew Voice system will show that both

processes identified in Arabic and Greek can co-exist in a language.

## 2.1 Verbal passivization in Semitic

According to Laks (2009), Semitic languages differ in terms of productivity of the formation of passive verbs and their distribution. For instance, passivization applies productively in Modern Standard Arabic (MSA): it is possible to form a passive counterpart for every transitive verb, as in English. Passive formation is regular and is performed by melodic overwriting, which can be described as follows: the vocalic pattern of a transitive verb changes into u-i and u-a in the perfective and imperfective verbs respectively, as shown in (4).

- (4) kasar 'break'  
**Passive:** kusir 'break-perf.'      yuksar 'break-impf'

In MSA, the formation of verbal passives is exception free. More importantly, however, MSA passive verbs have an exclusive passive meaning. This means that the forms with the vocalic patterns just illustrated do not host any other types of predicates, e.g. reflexives and anticausatives.

In contrast, according to Laks (2009), in Palestinian Arabic (PA), passivization is possible only if the verb is formed in two templates, fa<sup>a</sup>al, and fa<sup>o</sup>al. The process involves adding the prefix in- or t- to the active verb respectively:

- (5) a. katab                  inkatab                  'write'  
b. barra                  tbarra                  'buy'

Passivization in PA is not entirely productive even within these two templates; there are transitive verbs that do not have passive counterparts for no apparent reason, see (6):

- (6) wajaḍ                  \*inwajaḍ                  fiṇḍ  
maḡḡal                  \*tmawḡal                  fiṇḡaṇṡ

Unlike in MSA, the same form can be used with a number of meanings, i.e. the Voice system of PA is underspecified in Embick's (1998) sense: as Laks notes, the tfa<sup>o</sup>al template can be used in reflexive and anticausative construals, while the infa<sup>a</sup>al template is primarily used for passive and anticausative predicates. Both templates can host basic entries/deponent verbs, i.e. predicates that do not have a transitive variant:

(7)	<i>Anticausatives</i>	<i>Reflexives</i>	<i>Basic entries</i>
	twassax 'get dirty'	txabba 'hide onself'	traddad 'hesitate'
	infarad 'be unique'		

As Laks states, there are many verbs in other templates, which have no passive alternates, for morpho-phonological reasons, as shown in (5). As he argues, forming a passive verb would involve a very complex morpho-phonology, which cannot be handled by the phonological component and is therefore blocked. This is, in his analysis, precisely the type of restriction that can apply in the lexicon. In contrast, when operations that apply in the syntax, the morpho-phonology is transparent and is less subject to constraints, see the MSA data above.

(5)	istafraj	'extract'
	intaqad	'criticize'
	tbanna	'adopt'
	abt'al	'cancel'

Thus, Laks (2009) concludes that passive verbs in PA are derived directly from their active variants in the lexicon by applying word formation rules on existing words, when the application is possible. When the application is impossible, however, no passive verbal form is built. In contrast, passives in MSA are built in the syntax and every transitive verb can have a passive counterpart.

Laks's description leads to the following general conclusion: there is crosslinguistic variation also in the area of verbal passive formation. In some languages, passive morphology is directly linked with a passive interpretation, MSA, but also English and German being cases in point, while in other languages the morphology that is used in verbal passive formation can be found in other semantic-/syntactic environments, e.g. reflexives, anticausatives but also deponent verbs. Due to the lack of transparency, the low productivity and irregularity associated with the latter group, we could hypothesize, as Laks did, that their thematic operations are lexical.

## 2.2 Verbal passivization in Greek

The picture that Laks describes for PA is also found in Greek, see Tsimpli (1989), Embick (1998), Alexiadou, Anagnostopoulou & Schäfer (to appear) for discussion and references. In Greek, passive formation is synthetic as in Arabic. The language has two Voice paradigms, namely Active and Non-Active Voice. Passive verbs are built on the basis of non-active Voice, (9b).

(8)	Active	Non-Active	
Imperfective	graf-o	grafo-me	write
Perfective	grap-s-o	graf-t-o	

- (9) a. O Janis egrapse to vivlio  
John wrote the book
- b. To vivlio graftike apo to Jani  
the book wrote-NAct-3sg by John  
'The book was written by John'

To begin with, it has been noted that in Greek, there are many verbs that do not passivize, although their counterparts in English and German are perfectly passivizable. For instance, as Zombolou (2004), Alexiadou, Anagnostopoulou & Schäfer (to appear) report, most change of state verbs, but also several other verb classes cannot form a passive, see the list in (10):

- (10) haidevo 'stroke', tsimbao 'pinch', frondizo 'take care of', derno 'beat',  
klotsao 'kick', skotono 'kill', kovo 'cut', maherono 'stab', spao 'break',  
kriono 'cool', vatheno 'deepen', kondeno 'shorten', makreno  
'lengthen', alazo 'change' etc.

Similar to what we saw above for PA, Alexiadou, Anagnostopoulou & Schäfer (to appear) report that in several cases passive formation is out due to morpho-phonological constraints. As shown in (11), in some cases, a phonological clash results from the combination of a particular stem with the non-active affix:

- (11) \**kontinlike* 'shortened-NAct'  
\**leptinlike* 'thinened-NAct'  
\**makrinlike* 'lengthened-NAct'

Crucially, however, passive formation in Greek is non-transparent. In other words, like in PA, NAct is used in a variety of environments, namely it is found with certain anticausatives, dispositional middles, all reflexives, and deponent verbs, see Tsimpli (1989, 2006), Embick (1998), Alexiadou & Anagnostopoulou (2004), Zombolou (2004), Alexiadou & Doron (2012), Alexiadou, Anagnostopoulou & Schäfer (to appear) among others:

(12) <i>Anticausatives</i>	<i>Reflexives</i>	<i>Deponents</i>
<i>gremistike</i>	<i>plithike</i>	<i>metehiristike</i>
collapsed-NAct-3sg	washed-NAct-3Sg	used-NAct-3sg
<i>kaike</i>	<i>ksiristike</i>	<i>erhete</i>
burned-NAct-3sg	shaved-NAct-3sg	come-NAct-3sg



The class of deponent verbs will be discussed in section 4. Note here that, like in PA, some Greek deponents have no transitive counterpart, like ,come‘, while, unlike in PA, others have a transitive syntax (13); transitive deponents do not feed passivization and constitute a rather different puzzle from their intransitive counterparts.

- (13) O Janis metahiristike to leksiko  
 John used-NAct-3sg the dictionary-acc  
 'John used the dictionary'

Finally, while in English the external argument of the active transitive sentence can be realized as a by-phrase in the passive, *by*-phrases are severely restricted in Greek, either considered marked or only possible if the DP in the *by*-phrase is non-specific, see Philippaki-Warbuton (1975), Laskaratou & Philippaki-Warbuton (1984), Zombolou (2004).

- (14) a. O Petros ekapse to spiti  
 Peter burnt the house-acc  
 Peter burnt the house  
 b. to spiti kaike (\*apo ton Petro/?apo tus embristes)  
 the house burnt-NAct by the Peter/by the arsonists  
 The house was burnt by Peter/by the arsonists'

All these facts led to the proposal that passives in Greek are lexical and not syntactic, see e.g. Smyrniotopoulos (1992). Authors such as Klaiman (1991), Kaufmann (2004), and Manney (2000) argue in fact that Greek lacks a designated passive Voice, it actually only has middle Voice. Middle Voice subsumes a variety of readings, Kemmer (1993), unlike passive Voice. From the perspective of these authors, Middle Voice formation takes place in the lexicon, but see Alexiadou & Doron (2012), Spathas, Alexiadou & Schäfer (2013) for alternatives; thus not only does it derive intransitive verbs from transitive variants, but it can also apply to basic entries.

### 2.3 Two Voice heads

The description of Semitic and Greek verbal passive formation makes clear that the two processes are very different, this being the main reason why a lexical rule has been proposed to deal with verbal passives in PA and Greek, while MSA passive formation is seen as syntactic. The question that arises is whether we are able to offer an explanation of this empirical picture that is couched within a framework that assumes that verbal meaning is compositional and, more importantly, that there is no lexicon vs. syntax division. I will offer such an account in this section.

From the perspective of the framework of Distributed Morphology, a

piece-based, realizational theory of morphology, it has been proposed that we can reconstruct the two places, syntax vs. lexicon, for word formation without assuming two places, and in particular, without assuming a Lexicon. Marantz (2001) and Embick (2010) argue that this is possible, if we introduce a distinction between operations and the domain in which these apply, both structurally (position in the syntactic tree: high vs. low) and derivationally (involving what is called cyclic domains). According to Marantz (2001), the uniformity of morphophonology follows from the interpretive nature of the morphophonology, which uniformly follows the syntax. The uniformity of compositionality follows from having the syntax perform all merger operations.

Assuming then that there is only one generative component, namely syntax, the restrictions associated with passive formation are related to the type of head involved in the formation of verbal passives across languages. I argue, building on Alexiadou & Doron (2012), Alexiadou, Anagnostopoulou & Schäfer (to appear) and Spathas, Alexiadou & Schäfer (2013), that there are two heads implicated in argument alternations of the type discussed here: a low one, called here middle, and a high one, passive. While the type of the characterization that I will offer here does not correspond to the characterization offered in these works, it will be sufficient to account for the cross-linguistic differences discussed in the previous sections.

In Distributed Morphology, word formation processes make use of the following units: roots, and functional morphemes, e.g. categorizing heads (v), the projection introducing the external argument (Voice), Aspect, Tense, etc. It is generally assumed that external arguments are introduced above these categorizing heads. Kratzer labels this projection Voice (1996). Voice is a cyclic head in the sense of Embick (2010): it determines a special domain for interpretation and allomorphy.

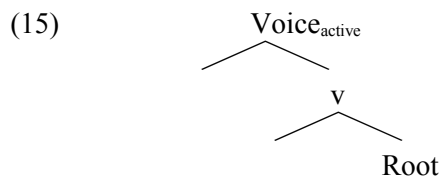

Following Alexiadou & Doron (2012), see also Bruening (2012), Alexiadou, Anagnostopoulou & Schäfer (to appear), and Spathas, Alexiadou & Schäfer (2013), I assume that there are two distinct non-active heads implicated in argument alternations, passive and middle (Doron 2003). Passive attaches outside the domain that introduces the external argument and thus has as its input a transitive structure. This is the case in English (and German), Bruening (2012), cf. Collins (2005). Middle is located lower, i.e. it is the non-active counterpart of Voice<sub>active</sub> in (15), cf. Marantz (2013), see (16):

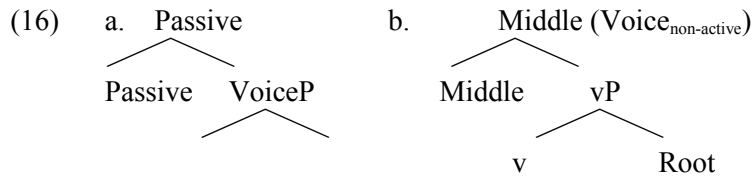

Languages such as English, German, and MSA are alike in that their passive merges high, it is above the projection that introduces the external argument. In other words, in languages of this type passive is an operation on an active transitive verb phrase, and it derives passive VPs, see also Merchant (2013). PA, and Greek, on the other hand, as well as other languages of this type, lack this head. Their verbs (v+ root) combine only with middle Voice. For Greek, in particular, this Voice head will be realized as non-active morphology, as in the absence of a specifier in Voice, which is the case with all intransitives, this head is spelled-out non-active (Embick 1998). A structure such as the one in (16b) is thus underdetermined for the semantic interpretation it can receive: as Spathas, Alexiadou & Schäfer (2013) argue, depending on the type of root included, it can yield a reflexive or a passive interpretation. More importantly, however, this structure is not dependent on there being a transitive entry, as is the case with the structure containing passive Voice. Since this structure is underspecified, speakers are relatively free to choose an interpretation that would go along with it. In addition, since (16b) forms a spell-out domain, we expect morpho-phonological restrictions to occur: the spell-out of Voice, a phase head, will be sensitive to the type of v-root complex that appears in its complement domain.

From this perspective then, what is subject to parametric variation is the availability of a passive head across languages: English, German, and MSA have such a head, while PA and Greek do not. Importantly, however, these two heads can both be present in a language. A case in point is Hebrew, where we find a complex interaction between agency heads and Voice, illustrated in (17) based on Doron (2003). In Hebrew, each root can appear in combination with three types of verbal template, namely the simple, the intensive and the causative one. These all affect verbal meaning in important respects, relating to the interpretation of the external argument, which will not be discussed here. These three templates can appear in three Voice templates, active, middle and passive. As can be seen in (17), taken from Doron (2030), the simple template has lost its passive Voice, while the causative one its middle Voice:

(17)	<b>root</b>	[p][n][y]	'face'	
		<b>active</b>	<b>passive</b>	<b>middle</b>
a. <b>simple</b>		[p]a[n]a[]	--	ni[f][n]a[]
		<i>to face/ turn (intrans.)</i>		<i>to turn oneself</i>

b. <b>intensive</b>	[p]i[n]a[] <i>to evacuate</i>	[p]u[n]a[] <i>to be evacuated</i>	hit[p]a[n]a[] <i>to vacate/evacuate oneself</i>
c. <b>causative</b>	hi[f][n]a[] <i>to turn (trans.)</i>	hu[f][n]a[] <i>to be turned</i>	--

What is of interest here is the interpretation of these combinations. As Doron (2003) notes, middle morphology (realized as either of the two middle templates *simple middle* and *intensive middle*) marks both anticausatives and reflexive verbs. There is no single causative-template verb interpreted reflexively.

(18)

*simple:*

[d][x][p]      [d]a[x]a[f]      *push*      ni[d][x]a[f]      *push oneself*

*intensive:*

[s][b][n]      [s]i[b]e[n]      *soap up*      his[t]a[b]e[n]      *soap up oneself*

In the simple template, the middle can have a passive interpretation, see (19), from Alexiadou & Doron (2012):

- (19) a.      ha-mexonit    nimxaca                      (al-yedey ha-masa'it).  
           the car            squash.SMPL.MID by            the truck  
           ‘The car was squashed (by the truck).’  
       b.      ha-nisuy            hitbacea'                      (al-yedey ha-xoqer).  
           the experiment perform.INTNS.MID by            the researcher  
           ‘The experiment was performed (by the researcher).’

In the intensive template, the passive yields a passive only interpretation, see (20), again from Alexiadou & Doron (2012), and it cannot be interpreted as e.g. anticausative as the *by-itself* phrase is out, (20b).

- (20) a.      ha-gader porqa            al-yedey    ha-mafginim.  
           the wall    dismantle.intns.pass by            the demonstrators  
           ‘The wall was dismantled by the demonstrators.’  
       b.      \*ha-gader porqa                      me-acma.  
           the wall    dismantle.intns.pass from itself  
           ‘The wall was dismantled by itself.’

Thus in the intensive template, a passive interpretation arises only in the context of passive morphology.

### 3. Dispositional middle formation

In the previous section, I established that languages may differ as to whether

or not they contain a passive Voice head, next to the active Voice head. Some languages simply make use of the non-active variant of the active Voice in (15), Greek, and PA being cases in point. With this in place, let us now turn to some differences in the domain of dispositional middles between English and Greek, and see whether we can derive them from the fact that Greek only has structure (15b) to build intransitive forms that bear non-active morphology.

As is well known, dispositional middles do not behave syntactically in a uniform way across languages, although they form a unified semantic class. In English, as Ackema & Schoorlemmer (1994) have shown, they exhibit properties of unergatives. On the other hand, in Greek, middles are formally identical to passives, i.e. they are unaccusative predicates, Lekakou (2005). I argue, in the spirit of Alexiadou & Doron (2012), that this is the case as in this language dispositional middles involve structure (16b), i.e. the same one as the passive. In contrast, in English dispositional middles make use of the structure in (15), i.e. they use an active Voice head.

There is ample evidence that dispositional middles in Greek are akin to unaccusative predicates. First of all, similar to passives, they tolerate *by* phrases (Tsimpli 1989, Lekakou 2005):

- (21) afto to vivlio diavazete efxarista (apo  
 this the book read-PASS-IMPERF-3SG with-pleasure by  
 opiondipote)  
 anyone  
 ‘This book reads with pleasure by anyone’ [lit.]

This is not the case in English:

- (22) \*Plates break easily by John.

Second, unaccusativity diagnostics point to the conclusion that middles are unergative in English, while they are unaccusative in Greek. For instance, prenominal modifier formation is out with dispositional middles in English:

- (23) \*the easily bribing men

In contrast, possessor sub-extraction, a test that diagnoses unaccusative predicates in Greek (Alexiadou & Anagnostopoulou 1999), is fine with dispositional middles in this language (Lekakou 2005):

- (24) tinos vleponde i tenies efkola  
 whose see-NONACT.IMPERF.3PL the-NOM film-NOM.PL easily  
 Whose movies watch easily?

In agreement with Lekakou (2005) and Condoravdi (1989), I assume that

middle is a semantic category and its syntactic realization differs across languages. In languages like Greek, middle makes use of the same non-active Voice head that passives and reflexives use. As a result, it has an unaccusative syntax. In languages like English, middle bears active morphology and it has an unergative syntax. Following Lekakou, the semantics of middles are licensed by imperfective morphology in Greek, which English lacks. As Lekakou argues, a language will employ a passive/unaccusative structure for the middle interpretation if and only if genericity is encoded in imperfective morphology. The definitions in (25)-(26) are from Lekakou (2005):

- (25) A language encodes genericity in imperfective morphology iff in at least one tense it has two distinct verb forms for generic and nongenerics uses, i.e. iff genericity → imperfectivity.
- (26) Middle interpretation = the ascription of a dispositional property to the Patient/Theme argument.

From Lekakou's perspective, dispositionality is subject-oriented genericity. This way Lekakou derives the genericity of the otherwise eventive verb and the obligatorily generic interpretation of indefinite subjects of middles. According to Lekakou, for the disposition ascription to target the patient/theme argument, this has to appear in subject position. In English, it appears in Spec, VoiceP, (27), and as a result dispositional middles behave like unergative in this language.

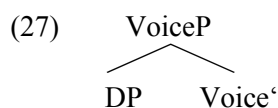

This explains why no *by* phrases can appear in English middles. This structure will be the input to a possibility modal that triggers the dispositional semantics (Alexiadou & Doron 2012) for details. Note that the structure in (27) should not necessarily be interpreted as involving base generation of the theme argument in Spec, Voice. It could very well be that the theme argument moves to Spec, VoiceP from a position below Voice, i.e. from the vP domain. As a result, the structure is spelled-out with active Voice, and feeds *-er* nominal formation, see Fujita (1994), and Schäfer (2008) for discussion.

#### 4. Deponent verbs

In the final section of this paper, I turn to deponent verbs, both intransitive and transitive ones as in (28) in Greek:

- (28) O Janis ekmetalevete ton Pavlo  
 the John-nom exploit-NAct3sg the Paul-acc  
 John exploits Paul

Deponents constitute a mismatch between form and function, see Baerman (2007), in the following sense. Predicates such as the one in (28) have a transitive syntax, but surface with non-active morphology on the verb. In contrast, predicates such as *erhome* 'come-Non-active' are intransitive, bear non-active morphology, but do not seem to have a transitive counterpart. Previous accounts of this mismatch all assume that there is something special about these predicates, and thus the information that they obligatorily surface with non-active morphology must somehow be listed (see e.g. Embick 2000, Kiparsky 2009, and others following them).

From the perspective of the discussion in sections 2 and 3, we must assume that deponents surface in structure (16b), i.e. they contain a non-active Voice head. The question that arises is why some of them have a transitive syntax and why others bear non-active morphology in the absence of a transitive entry. The latter issue can be straightforwardly accounted for under the system of Voice adopted in (16b), but something more needs to be said about transitive deponents.

To answer these questions, let us now consider some more facts about Greek deponent verbs, which will substantiate the observation that these belong to well-defined semantic classes, see also Oikonomou (2011) for Greek; see Xu, Aronoff & Anshen (2007) for Latin, Kallulli (2013) for Albanian. Zombolou & Alexiadou (2013) compiled a corpus of Greek deponents in order to be able to determine which classes these verbs belong to. This corpus includes the following verb classes: (a) verbs on which dictionaries and native speakers agree that they are deponent, i.e. they lack active counterparts (68%, e.g. *aminome* 'defend oneself'), (b) verbs that are reported as deponents in one dictionary while they are reported as non-deponents in others (19%, e.g. *idikevo* 'specialise sb./*idikevome* 'specialise'), (c) verbs that although they are reported to lack active counterparts by all dictionaries, native speakers use their active counterparts (2%, e.g. *kselemiazo-Act* 'stretch one's neck'/*kselemiazome* 'get a stretched neck'), (d) verbs that although they are reported to have active counterparts, their non-active form is reported to be more frequently used (6%, e.g. *vuvono* 'strike dumb'/*vuvonome* 'be struck dumb'), (e) verbs that have active counterparts on the basis of suffixation (3%, e.g. *fov[iz]o* 'frighten' vs. *fovame* 'fear'), and (f) verbs that have active forms, but these are associated with a different meaning than their non-active counterparts (2%, e.g. *viazoo* 'rape' vs. *viazome* 'be in hurry'). The corpus includes also those verbs that surface in non-active in the imperfective aspect, while they surface in the active in the perfective (e.g. *ginome/egina* 'become' or *erhome/irtha* 'come'). According to Zombolou & Alexiadou, the number of deponents in MG is 1,348 verbs out of

approx. 5,500 verbs (20%).

An examination of the morphological composition of deponent verbs carried out by the authors revealed that most of the verbs are denominal/deadjectival verbs, some are preceded by the prefixed *afto-* ‘oneself’ and *alilo-* ‘each other’ verbs, and fewer are compounds (13%), while very few verbs are root verbs (just 2%, e.g. *erhome* ‘come’ and *ime* ‘be’). In terms of interpretation, the denominal verbs denote that the verbal subject is affected by the base noun (e.g. *seliniazome* ‘be affected by the moon’, < *selini<sub>N</sub>* ‘moon’). The deadjectival ones denote either that the verbal subject is affected by the property denoted by the base adjective (e.g. *ironevome* ‘be ironic’, < *iron<sub>A</sub>* ‘ironic’) or that the verbal subject ends in the result state denoted by the base adjective (e.g. *enilikionome* ‘reach the age of an adult, become an adult’, < *enilikos<sub>A</sub>* ‘adult’). These types of readings fall well within the domain of middle Voice, see the discussion in Kemmer (1993).

We saw above that reflexive/reciprocal meaning can be expressed via the NAct-form. However, verbs prefixed by the *afto-* ‘oneself’ and *alilo-* ‘each other’ verbs are (mostly) non-deponent verbs (e.g. *eksipireto*-Act ‘serve’) which can have the passive meaning only by the NAct (e.g. *eksipiretume*-NAct ‘be served’). In order for these verbs to receive the reflexive/reciprocal meaning the prefixation by the *afto-* ‘oneself’ and *alilo-* ‘each other’ prefix respectively is obligatory (e.g. *aftoeksipiretume*-NAct ‘serve oneself’ and *aliloeksipiretumaste*-NAct ‘serve each other’; see Alexiadou to appear, Zombolou 2004 for discussion and references). Morphologically, *afto-* ‘oneself’ and *alilo-* ‘each other’ verbs must be considered as deponents since they lack Act-counterparts (*\*aftoeksipireto*-Act and *\*aliloeksipireto*-Act). This class of predicates has been explicitly argued to make use of middle Voice in Greek in Alexiadou (to appear), and Spathas, Alexiadou & Schäfer (2013), and will not be further discussed here.

According to Zombolou & Alexiadou (2013), the second largest semantic category consists of anticausatives denoting a spontaneous or physical event (e.g. *ekrignime* ‘explode’, *revome* ‘belch’, *enilikionome* ‘become/reach the age of an adult’, *thalassopnigome* ‘drown at sea’). The third semantic category includes cognitive/psych verbs (e.g. *skeftome* ‘think’, *mihanevome* ‘invent’, *fovame* ‘fear’, *esthanome* ‘feel’, *gevome* ‘taste’). What have been called active-like deponents are 11% of the verbs in the corpus (e.g. *ekmetalevome* ‘exploit, benefit’, *eborevome* ‘trade’, *metahirizome* ‘handle, use’). Some of the deponents are unaccusatives, e.g. *erhome* ‘come’, *afiknume* ‘arrive’, *aperhome* ‘leave a place’, while 8% of the deponents are passivized verbs; under this category Zombolou & Alexiadou classified compound verbs such as *iliokeome* ‘be burnt by the sun’ and *androkratume* ‘be dominated by men’, but also non-compound verbs such as the denominal verbs *itome* (<*ita* ‘defeat’) ‘be beaten/defeated’ and *idrevome* (<*idor* ‘water’) ‘be supplied with water, be watered’.

Zombolou & Alexiadou (2013) make three important observations.



First, deponent verbs form the 20% of the Greek verbal vocabulary; hence they are too numerous to be considered as relicts or idiosyncratic verbs. Second, they are very productive. As the diachronic study of the corpus carried out by Zombolou & Alexiadou shows, 13% of the corpus appeared in MG for the first time (< 1700 AC-today). Most importantly, however, novel deponents keep surfacing. Third, most of the deponents are reflexives/reciprocals, anticausatives, cognitive, and psych verbs. If these are reflexives, and anticausatives, then they can be analyzed as including a structure of type (16b), as discussed in the previous section. Importantly, however, even the verbs that have a transitive syntax can be analysed as benefactives or malefactives. These are verbs which denote that the verbal subject acts in her/his own interest so that she/he will be affected by her/his own action as well, e.g. *ekmetalevome* ‘exploit, benefit’, *eborevome* ‘trade’, *metahirizome* ‘handle, use’.

Building on these results, and see also the discussion in Oikonomou (2011), let me now discuss the syntax of this last class of deponents. It is generally agreed upon that experiencer arguments are arguments of the root, Pesetsky (1995). Moreover, benefactives are introduced by ApplP, below Voice (Pylkkänen 2008). This means that deponent verbs involve non-canonical external arguments in the following sense. Kratzer (1996) argued that if a language learner encounters a transitive verb that has an external argument that does not correspond to an active voice head in the basic repertoire (agent), then he/she has to assume a non-active syntax. From this perspective, experiencers/benefactors start as PPs, lower in the structure, importantly below Voice, and P incorporates into v-Voice, thus assigning accusative Case to the theme object (31). Via P-incorporation morphology, which extends the domain of the Appl head, see den Dikken (2007), Voice can become active, since the DP can now move to the specifier of Voice. Roussou & Tsimpli (2007) report several new formations of deponents with active morphology, an observation also made in Zombolou & Alexiadou (2013). These new active verbs can then feed passivization, which is otherwise impossible with transitive non-active deponents:

- (29) ja na *dhiaxirisun* tin idhia tus tin omadha (vs. *diaxiristun*)  
 for sub. manage the own theirs the-acc team manage-NAct-3pl  
 “...in order to manage their own team.”
- (30) a. ..oste na to *ekmetalefsume* gia ti diasinoriaki...  
 so.that sub. it exploit-1pl for the inter-borders  
 “... so that we can exploit it for the inter-borders ...”  
 b. i iroes tetjon istorion *ekmetalevonde* apo ta MME  
 the heroes such stories exploit.nact-3p by the media  
 “the heroes of such stories are being exploited by the media.”

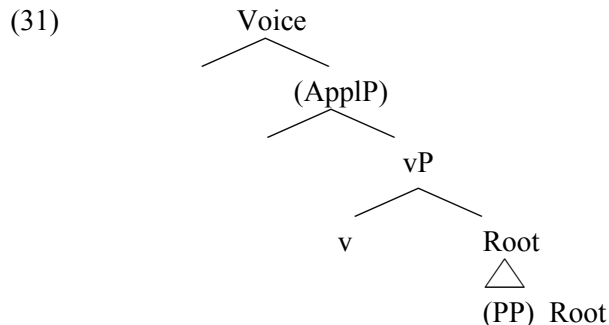

In this structure, the experiencer/benefactor gets Nominative via Agree with T, as it is the closest argument with which T can agree with.

But why do deponents bear non-active morphology? According to Oikonomou (2011), since Voice does not introduce the external argument, it can be realized as non-active (Embick 2004). However, sometimes it is realized as active, suggesting that P-incorporation is followed by movement of the DP to Spec,Voice. Since the DP can but must not move to VoiceP, the predicate can both appear with active and non-active morphology.

A final question that arises is what regulates the distribution of deponent verbs across languages. Deponent verbs cannot exist in languages such as English, where argument alternations are very regular. In this type of language, the passive will receive a passive only interpretation as the result of the availability of the structure (16a). In contrast, dispositional middles (as well as reflexives, see Alexiadou & Schäfer (2013)), will make use of structure (27), thus they will only appear in an active syntax. From the logic of the system developed here, deponent predicates are predicted to exist only in languages that have Voice syncretisms of the type identified for Greek, i.e. they only make use of the non-active counterpart of active Voice in (15), illustrated in (16b). Only in this type of language can a non-active Voice head occur with predicates that lack transitive counterparts to begin with; this is the case in Albanian and Latin, see Kallulli (2013) and Xu, Aronoff & Anshen (2007) respectively, languages that have Voice systems very similar to that of Greek.

## 5. Conclusion

In this paper, I showed how differences in the nature of Voice systems across languages are responsible for the behavior of passives, dispositional middles and also regulate the distribution of deponency. These relate to the height and the domain of the non-active head involved in argument structure alternations. In passive Voice languages such as English, passive takes as its input a transitive VoiceP/VP. In middle Voice languages such as Greek, middle is the non-active counterpart of active Voice, which explains why it is subject to a

number of restrictions and idiosyncrasy.

## References

- Ackema, P. & M. Schoorlemmer. 1994. The Middle Construction and the Syntax-Semantics Interface. *Lingua* 93, 59-90.
- Alexiadou, A. to appear. Roots in transitivity alternations: afto/auto reflexives. In A. Alexiadou, H. Borer & F. Schäfer (eds.) *The syntax of roots and the roots of syntax*. Oxford University Press.
- Alexiadou, A. & E. Anagnostopoulou. 1999. Tests for unaccusativity in a language without tests for unaccusativity. *Proceedings of the 3rd international conference on Greek Linguistics*. Athens, Ellinika Grammata, 23-31.
- Alexiadou, A. & E. Anagnostopoulou. 2004. Voice morphology in the causative-inchoative Alternation: evidence for a non unified structural analysis of unaccusatives. In A. Alexiadou, E. Anagnostopoulou, and M. Everaert (eds.) *The Unaccusativity puzzle*, 114-136. Oxford University Press.
- Alexiadou, A., E. Anagnostopoulou & F. Schäfer. to appear. *External arguments in transitivity alternations: a layering approach*. Oxford University Press.
- Alexiadou, A. & E. Doron 2012. The syntactic construction of two non-active Voices: passive and middle. *Journal of Linguistics* 48: 1-34.
- Alexiadou, A. & F. Schäfer 2013. Towards a non-uniform analysis of naturally reflexive verbs. *Proceedings of WCCFL* 31.
- Anagnostopoulou, E. 2003. Participles and Voice. In A. Alexiadou, M. Rathert & A. von Stechow (eds), *Perfect Explorations*. Berlin: de Gruyter, 1-36.
- Anderson, S. 1982. Where's morphology. *Linguistic Inquiry* 13: 571-612.
- Baerman, M. 2007. Morphological typology of deponency. In M. Baerman, G. Corbett, D. Brown, & A. Hippisley (Eds.) *Deponency and Morphological Mismatches*. Oxford University Press
- Bruening, B. 2012. By-Phrases in Passives and Nominals. *Syntax* 16: 1-41.
- Collins, C. 2005. A smuggling approach to the passive in English. *Syntax* 8: 81-120.
- Condoravdi, C. 1989. The Middle: where semantics and morphology meet. *MIT Working Papers in linguistics*, 11, 18-30.
- Dikken, Marcel den. 2007. Phase extension: contours of a theory of the role of head movement in phrasal extraction. *Theoretical Linguistics* 33.1:1-41
- Doron, E. 2003. Agency and voice: The semantics of the Semitic templates. *Natural Language Semantics* 11: 1-67.
- Doron, E. & M. Rappaport Hovav. 2009. A unified approach to reflexivization in Semitic and Romance. *Brill's Annual of Afroasiatic Languages and Linguistics* 1. 75-105.

- Embick, D. 1998. 1998. Voice systems and the syntax/morphology interface. In *MIT working papers in linguistics 32: Papers from the UPenn/MIT Roundtable on Argument Structure and Aspect*, 41–72. MITWPL, Department of Linguistics and Philosophy, MIT, Cambridge, Mass.
- Embick, D. 2000. Features, syntax, and categories in the Latin Perfect. *Linguistic Inquiry* 31:185-230.
- Embick, D. 2004. On the structure of resultative participles in English. *Linguistic Inquiry* 35.3:355-392.
- Embick, D. 2010. *Localism vs. globalism in morphology and phonology*. MIT Press.
- Fujita, K. 1994. Middle, ergative and passive in English: a minimalist perspective. *MIT Working Papers in Linguistics* 22: 71-90.
- Kallulli, D. 2013. Non-canonical passives and reflexives: deponents and their like. In A. Alexiadou & F. Schäfer (eds.) *Non-canonical passives*, 337-358. Amsterdam: John Benjamins.
- Kemmer, S. 1993. *The middle Voice*. Amsterdam: John Benjamins.
- Kiparsky, P. 2009. Verbal co-compounds and subcompounds in Greek. *MIT Working Papers in Linguistics* 57.
- Klaiman, M.H. 1991. *Grammatical Voice*. Cambridge. Cambridge University Press.
- Kratzer, A. 1996. Severing the External Argument from its Verb. In: J. Rooryck, L. Zaring (eds.), *Phrase Structure and the Lexicon*. Kluwer, Dordrecht, 109-137.
- Kratzer, Angelika (2000). Building statives. In L. Conathan, J. Good, D. Kavistkaya, A. Wulf & A. Yu (eds.), *Proceedings of the Berkeley Linguistic Society* 26, 385-399.
- Kaufmann, I. 2004. *Medium und Reflexiv – Eine Studie zur Verbsemantik*. Niemeyer, Tübingen.
- Laks, L. 2009. The formation of Arabic passive verbs: lexical or syntactic? *Proceedings of IATL* 25.
- Laskaratou, C. & I. Philippaki-Warburton. 1984. Lexical vs. transformational passives in Modern Greek. *Glossologia* 2-3, 99-109
- Lekakou, M. 2005. In the middle, somehow elevated. Ph.D. dissertation. UCL.
- Manney, L. 2000. *Middle voice in Modern Greek. Meaning and function of an inflectional category*. Studies in Language Companion Series. John Benjamins Publishing Company.
- Marantz, A. 2001. Words and Things. Ms., MIT & NYU.
- Marantz, A. 2013. Locating the verbal root. Paper presented at the 25th Scandinavian Conference of Linguistics, Iceland.
- Merchant, J. 2013. Voice and ellipsis. *Linguistic Inquiry* 44.1: 77-108.
- Oikonomou, D. 2011. Voice and argument structure: deponent verbs in Modern Greek. General Paper MIT.
- Pesetsky, D. 1995. *Zero syntax*. Cambridge, Mass.: MIT Press.

- Philippaki-Warbuton, Irene. 1975. The passive in English and Greek. *Foundations of Language* 13, 563-578.
- Pylkkänen, L. 2008. *Introducing arguments*. Cambridge, Mass.: MIT Press.
- Reinhart, T. & Siloni, T. 2005. The Lexicon-Syntax Parameter: Reflexivization and Other Arity. Operations. *Linguistic Inquiry* 36:389-436.
- Roussou, A. & I. Tsimpi. 2007. Clitics and transitivity. In Artemis Alexiadou (ed.), *Studies in the morpho-syntax of Greek*, 138-174. Cambridge: Cambridge Scholars Publishing.
- Schäfer, F. 2008. The syntax of anticausatives. John Benjamins.
- Smyrniotopoulos, J. 1992. *Lexical passives in Modern Greek*. Garland.
- Spathas, G. A. Alexiadou & F. Schäfer. 2013. Middle Voice and reflexivization: affixation in Greek. Ms., University of Stuttgart.
- Tsimpi, I.M. 1989. On the properties of the passive affix in Modern Greek. UCL. *Working papers in Linguistics*, 1, 235-260.
- Tsimpi, I.M. 2006. The acquisition of voice and transitivity alternations in Greek as native and second language. In *Paths of Development in L1 and L2 acquisition: In honor of Bonnie D. Schwartz*, eds. Sharon Unsworth, Teresa Parodi, Antonella Sorace, and Martha Young-Scholten, 15- 55. Amsterdam: John Benjamins.
- Wasow, T. 1977. Wasow, T. 1977. Transformations and the Lexicon. P. W. Culicover, T. Wasow & J. Bresnan (eds.) *Formal Syntax*, 327-360. New York: Academic Press.
- Xu, Z. M. Aronoff & F. Ahnsen 2007. Deponency in Latin. *Proceedings of the British Academy* 145: 127-143.
- Zombolou, K. 2004. Verbal alternations in Greek: a semantic analysis. PhD dissertation, University of Reading.
- Zombolou, K. & A. Alexiadou. 2013. The canonical function of the deponent verbs in Modern Greek. IN Franz Rainer, Wolfgang U. Dressler, Francesco Gardani & Hans Christian Luschützky: *Morphology and Meaning: Selected Papers from the 15th International Morphology Meeting*. Series: Current Issues in Linguistic Theory. John Benjamins.

# Simpler Syntax and explanation

Peter W. Culicover

The Ohio State University

Proceedings of the 20th International Conference on  
Head-Driven Phrase Structure Grammar

Freie Universität Berlin

Stefan Müller (Editor)

2013

Stanford, CA: CSLI Publications

pages 263–282

Culicover, Peter W. 2013. Simpler Syntax and explanation. In Stefan Müller (ed.), *Proceedings of the 20th International Conference on Head-Driven Phrase Structure Grammar, Freie Universität Berlin*, 263–282. Stanford, CA: CSLI Publications. DOI: 10.21248/hpsg.2013.14.



## Abstract

Simpler Syntax is an approach to grammar that calls for very restrictive limits on the notion of 'grammatical competence'. Specifically, it does not account for unacceptability judgments for sentences that are well-formed if they are fully licensed by the constructions of the language. SS leads us to seek accounts for such judgments in terms other than grammar per se, e.g., processing complexity, semantic or pragmatic well-formedness, discourse coherence, etc. I review several examples that suggest that the line that SS draws between competence on the one hand and performance and other mechanisms on the other is on the right track.

## 1 Introduction: What constitutes progress in linguistics?

What counts as progress in linguistics?<sup>1</sup> One way to gauge whether we are making progress, is to first be clear about what it is that we are trying to accomplish. In the case of syntax, we have essentially two options: (1) we can stick closely to the Chomskian program that has largely dominated the field since the 1960s, or (2) we can think 'outside of the box' and decide for ourselves what the goals of syntactic theory should be. Of course, following this second option does not preclude overlaps with the first, but it does mean that we may set goals for ourselves that may not always be widely shared.

The Chomskian premise is that there is an 'organ' of the mind that embodies the native speaker's knowledge of language. This knowledge is referred to as 'I-language', or competence (Chomsky 1986). Through interaction with various peripheral mechanisms, I-language accounts for the ability of the speaker to produce and understand sentences, the entire set of which comprises 'E-language'. Crucially, since this 'organ' is an expression of the human biological capacity for language, its architecture entails the existence of linguistic universals – those properties of languages that are not acquired through experience but imposed upon it by the structure and limitations of this 'organ'. The fundamental goal, as articulated in Chomsky 1965, is formulated narrowly in terms of linguistic competence: The theory makes available descriptively adequate grammars, and incorporates an evaluation metric that ranks competing descriptions of the same data; this

---

<sup>†</sup>I thank Ray Jackendoff for comments on an early version of this paper; the participants of the Workshop on Progress in Linguistics, and especially Gereon Müller, for helpful questions and comments, and Jefferson Barlew, Carmelo Bazaco, Lorena Sainz-Maza Lecanda, Susanne Winkler, Philip Hofmeister, William Schuler, Martin van Schijndel, Pajj Lintz, Dave Howcroft and the Synners discussion group at OSU. Thanks to Micha Elsner and Stefan Müller for helping me with L<sup>A</sup>T<sub>E</sub>X.

<sup>1</sup>Although the title of this workshop is "Progress in Linguistics", my remarks are focused on progress in syntax.

latter function is characterized in terms of an abstract model of the language learner. Such a theory defines the notion ‘possible language’ in terms of ‘possible grammar’ (along the lines of I-Language) and explains what we find in language in terms of ‘most highly ranked grammar’.

However, it is important to recognize that what such a theory seeks to explain – linguistic competence – is characterized in terms of grammaticality judgments. So at least on the more classical notion of the goals of a linguistic theory, the practical measure of success is progress in explaining these judgments. On the standard view, the grammar is responsible for judgments of grammaticality, while ‘performance’, that is, the real-time computation of the correspondence between sound and mean, is responsible for judgments of acceptability (Chomsky and Miller 1963; Chomsky 1965: Chapter 1).

One could go on at great length about what constitutes an explanation of grammaticality judgments in classical syntactic theory – see Chapters 2 and 3 of *Simpler Syntax* (SS; Culicover and Jackendoff 2005) for example. Rather, I focus here on where SS proposes that we draw the line between judgments that reflect grammar and judgments that reflect performance. Determining the location of this line constitutes progress, in that it makes it more likely that we will find explanations for the phenomena, rather than simply stating generalizations about the phenomena using the descriptive vocabulary of the grammatical theory. Along the way, SS also suggests a particular characterization of competence and performance that I think facilitates progress in finding explanations.

In §2 I summarize briefly the Simpler Syntax Manifesto and its implications for these issues. Then in §3 I discuss several cases where I think that drawing the line where SS proposes improves our chances of finding genuine explanations, rather than simply interesting statements of the problems. §4 draws a connection between the distinction drawn by SS and that of ‘hard’ and ‘soft’ constraints due to Sorace and Keller (2005). §5 is a brief conclusion.

## 2 The Simpler Syntax Manifesto

The Simpler Syntax Hypothesis (SSH) holds that syntactic descriptions should be no more complex than is necessary to account for interpretation, while still capturing all of the true syntactic and semantic generalizations. Reasons to believe that SSH is the right approach to syntactic analysis are given at some length in Culicover and Jackendoff 2005; 2006; I won’t try to review them here.

SS adopts the Parallel Architecture perspective of Jackendoff 2002, in which phonological, syntactic and semantic representations have their own well-formedness conditions, and are related to one another through correspondence rules. We assume that the basic components of grammars (both



in the head and in the linguistic description) are constructions, defined in terms of these correspondences. Particular syntactic structures participate in such correspondences to the extent that there are generalizations to be captured that go beyond the association of a particular basic form (such as a word) with a particular meaning. Following SSH, we assume, among other things, no abstract syntactic structure (i.e. no functional heads, no massive binary branching, etc.); no movement; no invisible constituents (except maybe A' trace); no UG syntactic constraints.

On this view, ‘grammatical rules’ are maximally general constructions with non-idiosyncratic, compositional interpretations. A particular phonological form with a meaning is licensed if every part of the meaning corresponds to some part of the form as licensed by some construction in the grammar.<sup>2</sup>

Here are some simple concrete examples. I adapt the AVM notations used in HPSG and by Fillmore 1988 and Kay 2005 to the Parallel Architecture of Jackendoff (2002). Following the PA, I assume that a correspondence consists of three co-subscripted representations, PHON, SYN and CS. The representation for the lexical item *eat* is given in (1). **EAT** is the concept that corresponds to the act of eating. V abbreviates the syntactic information about the word; subcategorization information must be understood to be part of this information although it is not represented here. (I use boldface to identify elements of CS.)

$$(1) \quad \textit{eat} \quad \left[ \begin{array}{ll} \text{PHON} & [\textit{it}]_1 \\ \text{SYN} & \mathbf{V}_1 \\ \text{CS} & \lambda y. \lambda x. \mathbf{EAT}_1(\text{AGENT}:x, \text{PATIENT}:y) \end{array} \right]$$

To keep things simple I ignore here the constructional details of inflected verbs.

Correspondences are licensed by constraint satisfaction, as in HPSG and Construction Grammar. For example, the construction for a non-idiomatic transitive VP is given in (2). The co-subscripting reflects the application of the correspondence rules that link components of PHON and SYN and components of SYN and CS.  $\varphi$  is a variable phonetic string. ‘-’ means ‘immediately precedes’.

$$(2) \quad \text{TRANSITIVE VP} \quad \left[ \begin{array}{ll} \text{PHON} & [\varphi]_1 - [\varphi]_2 \\ \text{SYN} & [\mathbf{VP} \ \mathbf{V}_1, \ \mathbf{NP}_2] \\ \text{CS} & \mathbf{V}_1(\mathbf{NP}_2) \end{array} \right]$$

---

<sup>2</sup>Hence meaning arrived at on line through metaphor cannot participate directly in such correspondences, but must be the consequence of inferential processes. Conventionalized coercion is, of course, part of meaning and therefore of correspondences.

This construction says that to form a VP, take a V and an NP that are sisters, linearize the form corresponding to V before that corresponding to NP, and apply the interpretation of V to the interpretation of NP. By assumption, this NP satisfies the subcategorization requirements of the verb.

A correspondence is licensed if there is a coindexing of its terms that satisfies the conditions imposed by the constructions of true language. This can be done by checking the PHON, SYN and CS of the particular correspondence against those of the constructions. For example, in (4) we check (3) against (1).

$$(3) \left[ \begin{array}{ll} \text{PHON} & [\text{it}] \\ \text{SYN} & V \\ \text{CS} & \lambda y. \lambda x. \mathbf{EAT}(\text{AGENT}:x, \text{PATIENT}:y) \end{array} \right]$$

$$(4) \left[ \begin{array}{ll} \text{PHON} & [\varphi]_1 \subseteq [\text{it}] \\ \text{SYN} & V_1 \subseteq V \\ \text{CS} & \lambda y. \lambda x. \mathbf{EAT}_1(\text{AGENT}:x, \text{PATIENT}:y) \subseteq \\ & \lambda y. \lambda x. \mathbf{EAT}(\text{AGENT}:x, \text{PATIENT}:y) \end{array} \right]$$

The properties of the construction constitute a subset of its properties. If the subset relation holds, then we coindex the correspondence so that it matches the construction, which licenses it as well-formed with respect to the construction.

To take a more complicated example, let the interpretation for *the pizza* be **PIZZA**[DEF]. Assuming the appropriate construction for the NP, the result of checking *eats the pizza* against the transitive VP construction (2) is (5).

$$(5) \text{ eat the pizza} \left[ \begin{array}{ll} \text{PHON} & [\dots]_1 - [\dots]_2 \subseteq [[\text{it}] - [\text{ðə pitsə}]] \\ \text{SYN} & [\text{VP } V_1, \text{NP}_2] \subseteq [\text{VP } [V \text{ eat}], [\text{NP } \text{the, pizza}]] \\ \text{CS} & \mathbf{V}_1(\mathbf{NP}_2) \subseteq \lambda y. \lambda x. \mathbf{EAT}(\text{AGENT}:x, \text{PATIENT}:y) \\ & ([\mathbf{PIZZA}[\text{DEF}]]) \end{array} \right]$$

The checking of PHON allows to assign subscripts to [it] and [ðə pitsə]. Checking of SYN goes through because the categories of the correspondence match those of the construction. The same holds for CS, assuming the appropriate semantic types and lambda-reduction.

Idioms and constructions with idiomatic properties take a similar form, where PHON specifies the linear order of elements, SYN describes the structure and CS the corresponding interpretation. Representations for *kick the bucket* and *sell NP down the river* are given in (6) and (7), respectively.

(6) *kick the bucket*

$$\left[ \begin{array}{l} \text{PHON} \quad [[\text{kik}_1 - [\check{\text{d}}_{\text{d}2} \text{ b} \Delta \text{k} \text{it}_3]_4]_5 \\ \text{SYN} \quad [\text{VP} [\text{vkick}]_1, [\text{NP} \text{ the}_2, \text{ bucket}_3]_4]_5 \\ \text{CS} \quad \lambda x. \mathbf{DIE}_5(\text{EXP}:x) \end{array} \right]$$

(7) *sell NP down the river*

$$\left[ \begin{array}{l} \text{PHON} \quad [\text{se} \text{l}]_1 - [\dots]_2 - [\text{d} \text{a}^{\text{u}} \text{n}_3 \check{\text{d}}_{\text{d}4} \text{ r} \text{iv} \text{r}_5]_6 \\ \text{SYN} \quad [\text{VP} \text{ sell}_1, \text{ NP}_2, [\text{PP} \text{ down}_3 [\text{NP} \text{ the}_4, \text{ river}_5]]_6] \\ \text{CS} \quad \lambda Y. \lambda X. \mathbf{BETRAY}_{6+1}(\text{AGENT}:X, \text{PATIENT}:Y)(\mathbf{NP}_2) \end{array} \right]$$

Because SS is a constructional theory, it strongly favors minimal syntactic structures to account for the correspondence between form and interpretation. For instance, given the sequence V-NP, if the corresponding interpretation is  $\mathbf{V}(\mathbf{NP})$ , it is simpler to state this directly in terms of the structure  $[\text{VP } V, \text{ NP}]$ , rather than posit a more abstract syntactic structure such as  $[\text{VP } V_i, \text{ NP}_j [\text{VP } t_i, t_j]]$  or something even more complex. In other words, the constructional approach per se does not rule out complex structures in which there are filler-gap chains, but under the SSH such structures would have to be strongly motivated by the facts. So SS assumes a filler-gap chain in  $A'$  constructions, for example, because doing so facilitates the interpretation, simplifies the grammatical description, and accounts for such things as unbounded dependencies and reconstruction effects.

Moreover, SS sharply restricts the scope of syntactic explanation to phenomena that have to do with the correspondence between syntactic structure and phonological form. It says for a given structure what the ordering possibilities of the constituents are, and what the morphological form of these constituents must or may be.

In other words, ‘grammatical competence’ in SS is a very restricted notion. Specifically, it does not account for unacceptability judgments for sentences that are well-formed if they are fully licensed by the constructions of the language, along the lines outlined above. Rather, it forces the explanation for such cases into other domains of explanation, e.g. semantic well-formedness, pragmatic coherence, processing, and so on.

### 3 Some cases

#### 3.1 Island constraints and SS

It follows that one important consequence of SS for theories of the representation of language in the mind is that island constraints like subadjacency, the complex NP constraint, the subject condition and the like are not grammatical phenomena in the narrow sense. There is in fact a growing literature that argues that they are the consequence of processing complexity arising

from particular configurations that are otherwise well-formed; see, for example, Kluender 1992; 1998; 2004; Hofmeister et al. submitted; Hofmeister et al. to appear; Hofmeister et al. 2007; Sag et al. 2007; Sag et al. 2008; Hofmeister and Sag 2010; Staum Casasanto et al. 2010; Hofmeister 2011; Hofmeister et al. 2012). Precisely **why** and **how** complexity gives rise to these effects is an intriguing question that I return to briefly below.

It is first instructive to reflect a little on why island constraints were considered to be part of the grammar, and in fact thought to be syntactic universals that constitute a part of the language faculty (Ross 1967; Chomsky 1977; Wexler and Culicover 1980). In early generative grammar, judgments of unacceptability were taken by default to be judgments of ungrammaticality, that is, to be accounted for by theories of competence. Except for obvious cases such as center-embedded relative clauses, there was no plausible account of such judgments in terms of performance. Since the island constraints applied not to particular constructions but to general configurations, it was reasonable to conclude that they were grammatical universals.

On the other hand, if these constraints are not a matter of grammar, they are universal only in the sense that they follow from properties of the universal processing mechanism. To show that this is plausible, I consider next an example where the data have very much the character of the kinds of data that motivated the island constraints, but the explanation is more likely to be external to grammar, as SS suggests. This conclusion supports in turn the view that the data that the island constraints account for should have a similar explanation. Then I consider a purported grammatical ‘freezing’ constraint that for which there is good empirical evidence that suggests that it is strictly the consequence of processing complexity.

### 3.2 Zero-relatives

In English it is possible to omit the relative marker *that* when a non-subject NP is relativized (Culicover in press).<sup>3</sup>

$$(8) \quad (\text{this is}) \text{ a book } \left\{ \begin{array}{c} \text{which} \\ \text{that} \\ \emptyset \end{array} \right\} \text{ you should read}$$

It is unacceptable in English to adjoin a constituent to the left periphery of a zero-relative clause, while similar adjunction to a marked relative following the relative marker is acceptable. A typical example is given in (9).

$$(9) \quad (\text{this is}) \text{ a book } \left\{ \begin{array}{c} \text{which} \\ \text{that} \\ * \emptyset \end{array} \right\} \text{ if you have time you should read}$$

---

<sup>3</sup>It is also possible to omit *that* when the subject is relativized in non-standard varieties.

A classical approach to such unacceptability would take the starred example to be ungrammatical, and formulate a grammatical account of this fact, either in terms of the configurations (i.e. what structures are possible or impossible, similar to the island constraints of Ross 1967), or a general constraint that blocks deletion of the complementizer (on analogy with application of the ECP to account for the *that-t* effect (Kayne 1984)).

I think that neither of these is the right type of solution. The evidence suggests that there is no simple syntactic characterization of the contexts that render zero-relatives unacceptable. Rather, the generalization appears to have to do with the identifiability of the relative clause on the basis of the sequence that marks its left periphery.

Here is the evidence. Note that it is possible, although somewhat complex, to position a non-subject constituent at the left periphery of a relative clause. This can be done in a number of ways, including topicalization, negative inversion, and stylistic inversion, illustrated in (10).

- (10) a. He is a man to whom<sub>*j*</sub> liberty<sub>*i*</sub>, we will never grant *t<sub>i</sub> t<sub>j</sub>*. [Baltin 1981]
- b. This is a dog  $\left\{ \begin{array}{c} \text{which} \\ \text{that} \end{array} \right\}_i$  under no circumstances should you ever try to feed *t<sub>i</sub>*. [Culicover 1992]
- c. Detroit is a town  $\left\{ \begin{array}{c} \text{where} \\ \text{in which} \\ \text{that} \end{array} \right\}$  in almost every garage can be found a car manufactured by GM.

Omitting the complementizer makes these examples less acceptable, as seen in (11).

- (11) a. \*He is a man<sub>*j*</sub> liberty<sub>*i*</sub> we will never grant *t<sub>i</sub> to t<sub>j</sub>*.<sup>4</sup>
- b. \*This is a dog<sub>*i*</sub> under no circumstances should you ever try to feed *t<sub>i</sub>*.
- c. \*Detroit is a town in almost every garage can be found a car manufactured by GM.

An important property of these constructions is that when there is no complementizer, there is nothing that marks the relative clause as such. I return to this point below.

A classical approach to the \*-ed examples in (9) and (11) would be to rule them out by invoking one or more grammatical principles, perhaps stated explicitly in terms of the observed structures. However, each of the structures in (11) is different. In the case of topicalization, the initial constituent is

---

<sup>4</sup>Note that (11a) is somewhat marginal even with *who* or *that*, because of the multiple extraction and stranded preposition.



The fact that (14b,c) are mildly unacceptable is consistent with the idea that the source of unacceptability here is not a matter of syntactic configuration per se, but of processing complexity. While the left edge of the zero-relative is not marked, it is not obscured by an initial non-subject.

Finally, it is possible to have sentential subjects in relative clauses instead of NPs. These configurations are complex, but they are more or less acceptable when the relative clause is introduced by a relative pronoun. However, when there is no marker for the relative clause, complete unacceptability follows. The (a) examples in (15) show marked relative clauses with sentential subjects, and the (b) examples show unmarked relative clauses with the same sentential subjects.<sup>5</sup>

(15) *that*-clause

- a. ? Otto appears to be a man [  $\left\{ \begin{array}{c} \text{who} \\ \text{that} \end{array} \right\}_i$  [s that it is snowing hard] apparently doesn't bother  $t_i$ ].
- b. \* Otto appears to be a man<sub>*i*</sub> [  $\emptyset_i$  [s that it is snowing hard] apparently doesn't bother  $t_i$ ].

(16) *for-to* infinitive

- a. ? Colette is the kind of woman [  $\left\{ \begin{array}{c} \text{who} \\ \text{that} \end{array} \right\}_i$  [s for us to speak better French] would probably have pleased  $t_i$ ].
- b. \* Colette is the kind of woman [  $\emptyset_i$  [s for us to speak better French] would probably have pleased  $t_i$ ].

(17) embedded *wh*-question

- a. ? We interviewed a candidate [  $\left\{ \begin{array}{c} \text{who} \\ \text{that} \end{array} \right\}_i$  [s whether it is polite to make eye contact] apparently was not obvious to  $t_i$ ].
- b. \* We interviewed a candidate [  $\emptyset_i$  [s whether it is polite to make eye contact] apparently was not obvious to  $t_i$ ].

It is important to stress that the judgments shown here are qualitatively no different from those that have been encountered in many other contexts in the course of syntactic theorizing over the past fifty-plus years. Some examples are strongly unacceptable, so that we might want to say that they are “ungrammatical”. Others are mildly unacceptable. In the case of phenomena such as extraction from islands it was possible to identify a relatively simple syntactic configuration that could be held responsible for the unacceptability. The same can be said for many other analyses, while

---

<sup>5</sup>These and other unacceptable examples can be rendered more acceptable by using intonation to signal the clause, which is another indication that what we are dealing with here is processing and not grammar.

recognizing that in many cases only the strongest unacceptability judgments could be accounted for in grammatical terms, while exceptions and gradient judgments were left out of the account. In the present case, we have seen that zero-relative clauses are unacceptable in cases of (i) topicalization, (ii) negative inversion, (iii) stylistic inversion, (iv) stacking and (v) sentential subjects. The diversity of syntactic configurations responsible for the unacceptability suggests that there is in fact no grammatical explanation for these judgments about zero-relatives.

This state of affairs is precisely what SS predicts. SS rules out (other things being equal), grammatical constraints that rule out otherwise well-formed syntactic configurations. SS forces us to seek explanations for such phenomena outside of syntax proper, e.g. in terms of processing, semantic well-formedness, pragmatics, discourse coherence, etc. As suggested above, a plausible place to look in the case of zero-relatives would be sentence processing. The reduction in acceptability occurs for reasons having to do with the particular linear string of elements, i.e. when there is no overt marker of a relative clause and the subject of the relative clause is not immediately adjacent to the head. My proposal is that in such a case, it is more difficult for the processor to recognize that there is a relative clause and correctly project the appropriate structure for further processing.

Why should difficulty of recognition lead to judgments of unacceptability? Assume, following Jackendoff (2002; 2007), that pieces of syntactic structure and their corresponding interpretations are “pieces of structure stored in memory”. Assume as well that the processing of a sentence proceeds from the beginning of the sentence by projecting possible continuations of the string in the form of hypothesized projected structure. For example, if the sequence is *the man that*, the complementizer *that* triggers a rule in the processor that projects the structure [DP *the man* [S-REL *that ...*]]. If the sequence is *the statement that*, there are (at least) two rules triggered: [DP *the fact* [S *that ...*]], as in *the fact that I disputed* and [[DP *the fact* [S-REL *that ...*]], as in *the fact that I disputed the result*.

Since at most if not all points in the processing there is typically more than one possible continuation, a plausible theory of sentence processing may take the perspective of a probabilistic phrase structure grammar, in which the probability of each expansion of a phrase at any point in the processing of the string is determined at least in part by the relative frequency of its structure in the corpus on which the parser has been trained (e.g. Nguyen et al. 2012).<sup>6</sup> An additional assumption is that the processing complexity of a sequence and, in extreme cases, its acceptability, is determined in part by the correspondence between the projected structure in the course of processing,

---

<sup>6</sup>The low or zero probability of a string of words with familiar structure but unfamiliar lexical items is not predicted to be unacceptable on this formulation. But a construction specified in terms of specific lexical items is predicted to be unacceptable when it contains a lexical item that is not typically used in this construction.



and the actual structure settled on (Hale 2001; 2003; Levy 2005; 2008). In the case of *the fact that*, for example, the probability of the sentential complement analysis is greater than that of the relative clause analysis. In the relative clause case there is a significant slowdown in reading times, suggesting that there is greater processing complexity at the gap, when the processor realizes that the correct structure is that of a relative clause (Chen et al. 2005). Ungrammatical sentences of course have virtually zero probability of occurrence, so they will be judged highly unacceptable.

Consider now the case of the zero-relative. When there is no explicit marker at the left edge of the relative clause, the processor must depend on other familiar evidence to project the structure, i.e. an initial subject DP. Topicalization in relative clauses even with overt markers appears to be very rare. Since zero-relatives are frequent in English, a sequence such as *a man we (could never grant liberty to)* can be reliably assigned the structure [DP *a man* [S-REL *we ...*]], where *we* is clearly the subject of the relative clause. In example (15) the initial sequence is *a man liberty*, which can be reliably assigned the structure [[DP [S-REL *liberty ...*]], where *liberty* is the subject of the relative clause. But in the sequence *a man liberty we*, the subject of the relative clause is actually *we*. There is no basis for treating *liberty* as a topicalized DP with a following subject DP, presumably because the sequence DP-DP-DP does not occur in the corpus. The absence of a rule for processing this sequence leads the process to engage in some type of repair strategy, with a corresponding reduction in acceptability.

Finally, the less than fully acceptable zero-relatives appear to be very rare or non-existent in the corpus. The interaction between probability and judgments in extreme cases appears to account for the judgments in examples (9)-(17).

### 3.3 Freezing

Consider in this regard the phenomenon of ‘freezing’. Ross (1967:305) observed that extraction from a PP that has been extraposed is reduced in acceptability, as shown by (18b).

- (18) a. You saw [a picture] yesterday [PP of Thomas Jefferson].  
 b. ?Who<sub>i</sub> did you see [a picture *t<sub>j</sub>*] yesterday [PP of *t<sub>i</sub>*]<sub>j</sub>?

Ross’s (1967) formulation of the Frozen Structure Constraint in (15) deals specifically with such examples.

- (19) The Frozen Structure Constraint (FSC): If a constituent C, where C is a clause or a prepositional phrase, has been extraposed from a noun phrase whose head is lexical, this noun phrase may not be moved, nor may any element of C be moved out of C (pp. 160, 165).

Subsequently, Wexler and Culicover (1980) proposed the Freezing Principle, based on considerations of language learnability. The basic idea was that a structure that is created transformationally that is not compatible with the base phrase structure rules of a language is frozen. Such a derivation is non-structure-preserving, in the sense of Emonds (1970; 1976). However, note that an extraposed PP is in the position of an argument or adjunct PP in the VP, and hence should not be frozen on the Wexler-Culicover definition of freezing.

Culicover and Winkler (2013) in fact propose that the unacceptability of extraction from an extraposed PP depends in large part, if not entirely, on the fact that it demands that the gap corresponding to the extracted filler is inside of a constituent whose connection to a preceding head is unanticipated, which results in processing complexity. The structure is given in (20).

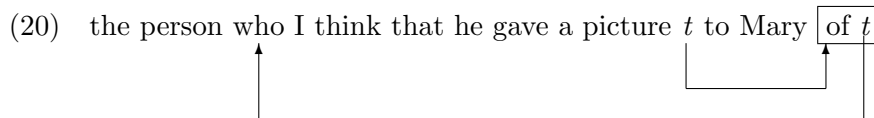

As before, if processing complexity leads to the avoidance of certain configurations, such configurations will have lower probability and therefore produce judgments of lower acceptability. With this in mind, Hofmeister et al. (2012) did several experiments to confirm that distance-based effects on acceptability judgments occur in the case of extraction and in the case of extraposition. The results strongly resemble findings from the psycholinguistics literature on effects of dependency locality (Gibson 1998; 2000; Grodner and Gibson 2005): in general, the longer the dependency, the lower the acceptability judgment. Hofmeister et al. constructed an experiment in order to determine if the acceptability judgments due to extraposition and extraction in combination are in some way dependent on the two factors occurring together in the same examples, that is, if there is a measurable freezing effect. A sample of the examples used in this experiment is given in (21).

- (21) a. Tell me which actor your friend read a story about twice while having breakfast.  
 b. Tell me which actor your friend read a story twice about while having breakfast.  
 c. You told me your friend read a story about an actor twice while having breakfast.  
 d. You told me your friend read a story twice about an actor while having breakfast.

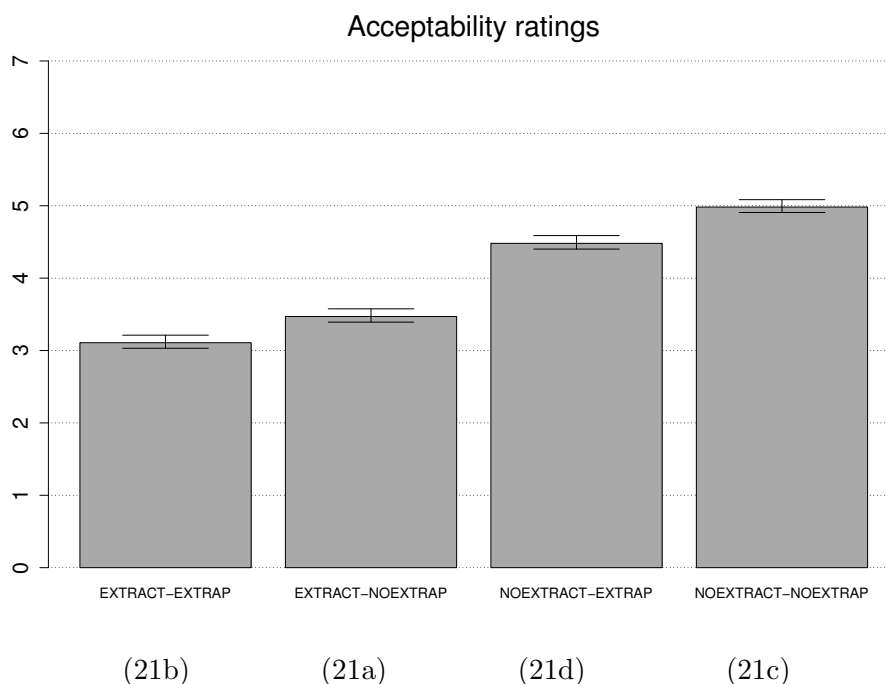

Figure 1: Mean acceptability judgments from Experiment. Error bars show  $\pm 1$  standard error.

This design allows us to determine how much extraposition and extraction independently lower judgments, and whether combining the two lowers judgments beyond what is expected on the basis of each independent source of unacceptability.

The results of this experiment are summarized in Figure 1. The figure shows that there is no interaction: extraposition is no worse in contexts with extraction, (21b), than in contexts without, (21d). The freezing violations in (21b) have an average rating that is predictable on the basis of the independent average penalties for extraposition and extraction. The data suggest that the low ratings for freezing violations are in fact attributable solely to the combined penalties resulting from extraction and extraposition. This experiment appears to eliminate the need for any constraint specific to the freezing configuration. Rather, this freezing effect appears to be due entirely to processing complexity.

This analysis of freezing phenomena illustrates once again the implications of SS for explanation of judgments. These acceptability judgments cannot be accounted for in the grammar per se, because the configurations that produce them cannot be formulated in terms of constructions. The sentences are strictly speaking well-formed, in that every local configuration conforms to the requirements of the grammar. Therefore, SS suggests that

the judgements fall outside of grammar. Processing complexity may not be the correct account in every case, but at least in the cases I have reviewed here it appears to offer a plausible account.<sup>7</sup>

## 4 Hard and soft constraints

The line drawn by SS brings to mind a distinction made by Sorace and Keller (2005), as follows: “We assume a fundamental dichotomy between hard constraints (that trigger categorical linguistic judgments) and soft constraints (that trigger gradient judgments).” Since SS distinguishes sharply between those phenomena that are the province of well-formedness and those that are not, the distinction drawn by SS may provide a basis for the hard/soft distinction. Sorace and Keller categorize as ‘hard’ constraints cases such as the following:

- (22) Hard constraints on extraction
- a. INVERSION (INV): subject and auxiliary have to be inverted.
  - b. AGREEMENT (AGR): subject and verb have to agree in number.
  - c. PRESUMPTIVE (RES): resumptive pronouns are disallowed in wh-questions.

These are all what we would take to be constructional well-formedness conditions and therefore a matter of grammar – by definition, they admit of no exception. On the other hand, ‘soft’ constraints are those that yield gradient judgments. SS requires that gradient phenomena fall outside of the grammar – they must be the result of variable processing complexity, or perhaps reflect aspects of discourse complexity and coherence that are sensitive to contextual effects. Some examples of ‘soft’ constraints cited by Sorace and Keller with respect to extraction from NP are the following:

- (23) Soft constraints on extraction
- a. DEFINITENESS (DEF): a picture NP is marked [-DEFINITE].

---

<sup>7</sup>When it comes to irregularities and idiosyncrasies, processing complexity certainly is not the only plausible story. Low or zero frequency of occurrence in the corpus can occur for a variety of reasons that have nothing to do with complexity. For instance, there are collocations, such as *(to look) high and low* but *\*(to look) low and high*. In the sluice-stranding construction (Culicover 1999), certain combinations of wh-phrase and preposition are possible while others are not, for no apparent reason, e.g. *who with, what about* but *\*who about, \*who next to, \*what under*. Regardless of the source, low frequency appears to produce judgments of unacceptability, however. This said, frequency must be measured against a background of expectation, since individual words, phrases and especially sentences may be of very low frequency and yet be perfectly acceptable, as Chomsky (1965) noted.

- b. VERBCLASS (VERB): a verb subcategorizing for a picture NP has to be marked [-EXISTENCE].
- c. REFERENTIALITY (REF): an NP extracted from a picture NP has to be marked [+REFERENTIAL].

These constraints all arguably reflect complexities in the construction of coherent discourse representations.

The differences between these two types of constraints are precisely what SS predicts. Sorace and Keller’s hard constraints are those that produce strong unacceptability, are minimally sensitive to context and show no developmental optionality, that is, they are faithfully observed in development. Soft constraints, on the other hand, produce mild unacceptability, are sensitive to context and show developmental optionality. In present terms, the ‘hard’ constraints produce judgments of ungrammaticality, while the ‘soft’ constraints produce extragrammatical judgments of unacceptability on well-formed structures.

## 5 Conclusions

SS is a constructional theory that makes very restrictive assumptions about what falls within the domain of syntactic competence. Competence is limited to well-formedness as defined by constructions, as exemplified by (2).

$$(2) \quad \text{TRANSITIVE VP} \\ \left[ \begin{array}{ll} \text{PHON} & [\varphi]_1 - [\varphi]_2 \\ \text{SYN} & [\text{VP } V_1, \text{NP}_2] \\ \text{CS} & \mathbf{V}_1(\mathbf{NP}_2) \end{array} \right]$$

So, if a VP is not properly linearized, or if its interpretation does not conform to the CS as given here or to any idiomatic CS, the sentence that contains it is ungrammatical. Any sentence that is fully licensed by conforming to the set of constructions of the language is grammatical in the strict sense. If such a sentence is judged to be unacceptable in some way, the unacceptability judgment is not a matter of grammar, but something else. For the cases that I have discussed, I suggest that processing is responsible.<sup>8</sup>

In sum, SS draws the line between competence and performance so that everything that does not have to do with satisfying the conditions of constructions in a grammar is not competence. All judgments that cannot be accounted for in constructional terms must be explained in other ways. Of course, SS does not automatically provide explanations for such judgments

---

<sup>8</sup>I suspect that this is the case for a substantial number of judgments cited in the literature as “ungrammatical” that have formed the basis of proposals that have found their way into the theoretical literature, but this is far too big an issue to take on here.

– theories of processing, discourse structure and so on have to be independently formulated and verified. But it does make clear claims about where to find explanations, and, to the extent that the explanations are there, one can argue that progress is being made.

## References

Baltin, Mark. 1981. Strict bounding. The logical problem of language acquisition, ed. by Lee Baker and John Mccarthy, 247-95. Cambridge, MA: MIT Press.

Chen, Evan, Edward Gibson, and Florian Wolf. 2005. Online syntactic storage costs in sentence comprehension. *Journal of Memory and Language* 52.144-69.

Chomsky, Noam. 1965. *Aspects of the theory of syntax*. Cambridge, MA: MIT Press.

Chomsky, Noam. 1977. On wh movement. *Formal syntax*, ed. by Peter W. Culicover, Thomas Wasow, and Adrian Akmajian, 71-132. New York: Academic Press.

Chomsky, Noam. 1986. *Knowledge of language: Its nature, origin, and use*. New York: Praeger.

Chomsky, Noam and George A Miller. 1963. Introduction to the formal analysis of natural languages. *Handbook of Mathematical Psychology*, vol. 2, ed. by R.D. Luce, R.R. Bush, and E. Galanter, New York: Wiley.

Culicover, Peter W. 1992. Topicalization, inversion, and complementizers in English. *OTS Working Papers*. University of Utrecht, Utrecht. *Going Romance and Beyond* pp 1-43. Reprinted in Peter W. Culicover. 2013. *Explaining Syntax*. Oxford: Oxford University Press.

Culicover, Peter W. in press. English zero-relatives and the competence-performance distinction. *Papers dedicated to Mike Harnish*. *International Review of Pragmatics*.

Culicover, Peter W. and Ray Jackendoff. 2005. *Simpler syntax*. Oxford: Oxford University Press.

Culicover, Peter W. and Ray Jackendoff. 2006. The simpler syntax hypothesis. *Trends in Cognitive Sciences* 10.413-18.

Culicover, Peter W., Levine, Robert. D. 2001. Stylistic inversion in English: A reconsideration. *Natural Language & Linguistic Theory* 19, 283-310. Reprinted in Peter W. Culicover. 2013. *Explaining Syntax*. Oxford: Oxford University Press.

- Culicover, Peter W. and Susanne Winkler. 2013. Freezing: A conspiracy. Unpublished ms. Ohio State University and University of Tuebingen.
- Emonds, Joseph. 1970. Root and structure preserving transformations. Bloomington, Indiana: Indiana University Linguistics Club.
- Emonds, Joseph. 1976. A transformational approach to English syntax. New York: Academic Press.
- Fillmore, Charles J. 1988. The mechanisms of construction grammar. BLS 14.35-55.
- Gibson, Edward. 1998. Linguistic complexity: Locality of syntactic dependencies. *Cognition* 68.1-76.
- Gibson, Edward. 2000. The dependency locality theory: A distance-based theory of linguistic complexity. Image, language, brain, ed. by Yasushi Miyashita, Alec Marantz, and Wayne O'Neil, 95-126. Cambridge, MA: MIT Press.
- Grodner, Daniel J. and Edward A. F. Gibson. 2005. Consequences of the serial nature of linguistic input for sentential complexity. *Cognitive Science* 29.261-91.
- Hale, John T. 2001. A probabilistic Earley parser as a psycholinguistic model. Proceedings of the second meeting of the North American Chapter of the Association for Computational Linguistics on Language technologies. 1-8.
- Hale, John T. 2003. The information conveyed by words in sentences. *Journal of Psycholinguistic Research* 32.101-23.
- Hofmeister, Philip. 2011. Representational complexity and memory retrieval in language comprehension. *Language and Cognitive Processes* 26.376-405.
- Hofmeister, Philip, Inbal Arnon, T. Florian Jaeger, Ivan A. Sag, and N. Snider. submitted. The source ambiguity problem: Distinguishing the effects of grammar and processing on acceptability judgments. *Language and Cognitive Processes*
- Hofmeister, Philip, Peter W. Culicover, and Susanne Winkler. 2012. Effects of processing on the acceptability of 'frozen' extraposed constituents. To appear, *Syntax*.
- Hofmeister, Philip, T. Florian Jaeger, Ivan A. Sag, Inbal Arnon, and Neal Snider. 2007. Locality and accessibility in wh-questions. *Roots: Linguistics in search of its evidential base*, ed. by Sam Featherston and Wolfgang Sternefeld, 185-206. Berlin: de Gruyter.

- Hofmeister, Philip and Ivan A. Sag. 2010. Cognitive constraints and island effects. *Language* 86.366-415.
- Hofmeister, Philip, Laura Staum Casasanto, and Ivan A. Sag. to appear. Islands in the grammar? Standards of evidence. *Experimental syntax and island effects*, ed. by Jon Sprouse and Norbert Hornstein, Cambridge: Cambridge University Press.
- Jackendoff, Ray. 2002. *Foundations of language*. Oxford: Oxford University Press.
- Jackendoff, Ray. 2007. A parallel architecture perspective on language processing. *Brain Research* 1146.2-22.
- Kay, Paul. 2005. Argument structure constructions and the argument-adjunct distinction. *Grammatical constructions: Back to the roots*, ed. by Mirjam Fried, 71-98. Amsterdam: John Benjamins.
- Kayne, Richard S. 1981. ECP extensions. *Linguistic Inquiry* 22.93-133.
- Kluender, Robert. 1992. Deriving island constraints from principles of predication. *Island constraints: Theory, acquisition and processing*, ed. by Helen Goodluck and Michael Rochemont, 223-58. Dordrecht: Kluwer.
- Kluender, Robert. 1998. On the distinction between strong and weak islands: A processing perspective. *The limits of syntax*, ed. by Peter W. Culicover and Louise McNally, 241-79. New York: Academic Press.
- Kluender, Robert. 2004. Are subject islands subject to a processing account? *Proceedings of wccfl 23*, ed. by Benjamin Schmeiser, Vineeta Chand, Ann Kelleher, and Angelo Rodriguez, 101-25. Somerville, MA: Cascadilla Press.
- Levy, Roger. 2005. Probabilistic models of word order and syntactic discontinuity. Department of Linguistics: Stanford University dissertation.
- Levy, Roger. 2008. Expectation-based syntactic comprehension. *Cognition* 106.1126-77.
- Nguyen, Luan, Marten Van Schijndel, and William Schuler. 2012. Accurate unbounded dependency recovery using generalized categorial grammars. *Proceedings of the 24th International Conference on Computational Linguistics (COLING '12)*.
- Ross, John R. 1967. *Constraints on variables in syntax*. Cambridge, MA: MIT dissertation.
- Sag, Ivan A., Philip Hofmeister, Inbal Arnon, Neal Snider, and Florian Jaeger. 2008. Processing accounts for superiority effects. Stanford.



Sag, Ivan A., Philip Hofmeister, and Neal Snider. 2007. Processing complexity in subadjacency violations: The complex noun phrase constraint. Proceedings of the 43rd Annual Meeting of the Chicago Linguistic Society. Chicago.

Sorace, Antonella and Frank Keller. 2005. Gradience in linguistic data. *Lingua* 115.1497-524.

Staum Casasanto, Laura, Hofmeister, Philip, and Ivan A. Sag. 2010. Understanding acceptability judgments: Additivity and working memory effects. Proceedings of the 32nd Annual Conference of the Cognitive Science Society. Austin, TX.

Wexler, Kenneth and Peter W. Culicover. 1980. Formal principles of language acquisition. Cambridge, MA: MIT Press.